

BARCO

BARCO PROJECTION SYSTEMS

Cine

BARCO ^{Ciné}₈

R9002390-R9002391-R9002392
R9002397-R9002398-R9002399

INSTALLATION MANUAL

R9002390 : Ciné 8 230V
R9002391 : Ciné 8 + LIDO 230V
R9002392 : Ciné 8 + LIMO 230V
R9002397 : Ciné 8 + LIMO 120V
R9002398 : Ciné 8 + LIDO 120V
R9002399 : Ciné 8 120V

Due to constant research, the information in this manual is subject to change without notice.

Produced by BARCO NV, February 2000.
All rights reserved.

Trademarks are the rights of their respective owners.

BARCO n.v./Projection Systems

Noordlaan 5

B-8520 Kuurne

Belgium

Tel : +32/56/368211

Fax : +32/56/351651

E-mail : sales.bps@barco.com

Visit Barco at the web : <http://www.barco.com>

Printed in Belgium

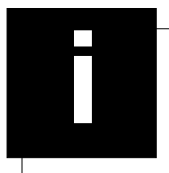

TABLE OF CONTENTS

TABLE OF CONTENTS	I-1
SAFETY INSTRUCTIONS	1-1
Safety Instructions	1-1
Notice on Safety	1-1
installation INSTRUCTIONS	1-1
OWNER'S RECORD	1-1
Safety indication on the product	1-1
Safety Warning	1-2
FEDERAL COMMUNICATION COMMISSION (FCC STATEMENT)	1-2
On Safety	1-2
On installation	1-3
On servicing	1-3
On cleaning	1-3
On repacking	1-3
On illumination	1-3
UNPACKING AND PROJECTOR DIMENSIONS	2-1
Projector Packaging	2-1
Way of Packaging	2-1
Unpacking	2-1
Hint	2-1
Contents of the shipping carton :	2-1
Projector dimensions (in mm)	2-2
INSTALLATION GUIDELINES	3-1
Installation guidelines	3-1
Ambient Temperature Conditions	3-1
Humidity Conditions	3-1
Environment	3-1
What about ambient light ?	3-1
Which screen type?	3-1
What image size? How big should the image be?	3-1
Where to install the projector ?	3-2
Scan Adaptations	3-3
Access to Scan Controls	3-3
Scan Inversion	3-4
Note	3-7
Check Procedure	3-7
PROJECTOR SETUP	4-1
Projector Set Up	4-1
How and What to set up ?	4-1
Access to the DIP switches	4-1
Setting the projector address	4-2
Powerup mode	4-3
Baud Rate for communication with a computer	4-4
Password mode	4-4

AC POWER CONNECTION	5-1
Power Connection	5-1
AC Power (mains) cord connection	5-1
Preparing your power cord	5-1
AC Power check	5-2
AC Input power (mains) voltage adaptation	5-2
Fuses	5-3
Switching on	5-3
Start up in Operational Mode	5-3
Start up in Stand by Mode	5-4
Which source to which input.....	6-1
SOURCE CONNECTIONS	6-1
Input Source Connection	6-1
Input facilities	6-1
Connecting a Composite Video source.	6-2
Connecting a S-Video or Video source to port 2.	6-2
6-4	
Connecting a RGB Analog source to port 3	6-4
Connecting a RGB Analog source with composite sync to port 4/5.	6-6
Connecting a RGB Analog source with Tri-level sync.	6-6
Connecting a Component source.	6-7
Connecting a Component source with Tri-level sync.	6-7
RS232 Connection.....	6-7
RS232 input and RS232 output of the projector.	6-7
Communication port for communication with peripherals	6-8
Connecting a RCVDS 05 switcher to the projector.	6-8
Connecting a VS05 switcher to the projector.	6-8
Connecting an IR Remote Receiver to the projector.	6-8
INSTALLATION ADJUSTMENT MODE	7-1
Installation Adjustments	7-1
How to enter the Service Menus ?	7-1
Installation Adjustment Mode Start Up	7-1
Overview flowchart of the Installation Adjustment Mode	7-2
Important : Access to adjustments	7-2
Projector Distance	7-2
What can be done ?	7-2
Optical Lens Focusing.....	7-3
What has to be done ?	7-3
How to focus the lenses ?	7-3
Raster Centering.....	7-3
What has to be done ?	7-3
Warning	7-3
How to adjust ?	7-3
CRT Projection Angle Adjustment	7-4
What has to be done ?	7-4
NOTE	7-4
How to adjust ?	7-4
Scheimpflug Adjustment (Diagonal image focusing)	7-6
What can be done ?	7-6
How to adjust ?	7-6
Finishing the installation mode.	7-7
G2 ADJUSTMENT	A-1
G2 Adjustment	A-1
How to start up the G2 adjustment ?	A-1

GAMMA CORRECTIONS	B-1
Gamma Corrections	B-1
Warning Entering Gamma corrections	B-1
How to adjust ?	B-1
Blue Gamma Correction	B-1
Red and Blue Midlights Correction	B-2
Back to the factory preset values	B-2

1

SAFETY INSTRUCTIONS

Safety Instructions

Notice on Safety

This equipment is built in accordance with the requirements of the international safety standards EN60950, UL 1950 and CSA C22.2 No.950, which are the safety standards of information technology equipment including electrical business equipment.

These safety standards impose important requirements on the use of safety critical components, materials and isolation, in order to protect the user or operator against risk of electric shock and energy hazard, and having access to live parts.

Safety standards also impose limits to the internal and external temperature rises, radiation levels, mechanical stability and strength, enclosure construction and protection against the risk of fire.

Simulated single fault condition testing ensures the safety of the equipment to the user even when the equipment's normal operation fails.

INSTALLATION INSTRUCTIONS

Before operating this equipment please read this manual thoroughly, and retain it for future reference.

Installation and preliminary adjustments should be performed by qualified BARCO personnel or by authorized BARCO service dealers.

OWNER'S RECORD

The part number and serial number are located at the back side of the projector. Record these numbers in the spaces provided below. Refer to them whenever you call upon your BARCO dealer regarding this product.

PART NUMBER :

SER. NUMBER :

DEALER :

Safety indication on the product

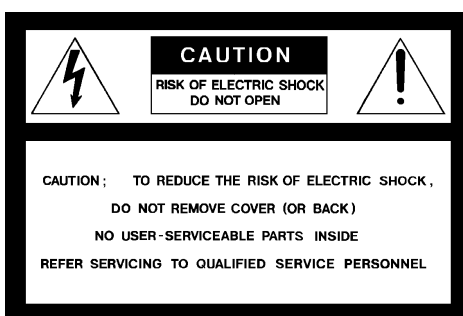

The lightning flash with an arrowhead within a triangle is intended to tell the user that parts inside this product may cause a risk of electrical shock to persons.



The exclamation point within a triangle is intended to tell the user that important operating and/or servicing instructions are included in the technical documentation for this equipment.

Safety Warning

TO PREVENT FIRE OR ELECTRICAL SHOCK HAZARD, DO NOT EXPOSE THIS EQUIPMENT TO RAIN OR MOISTURE

FEDERAL COMMUNICATION COMMISSION (FCC STATEMENT)

This equipment has been tested and found to comply with the limits of a class A digital device, pursuant to Part 15 of the FCC Rules. These limits are designed to provide reasonable protection against harmful interference when the equipment is operated in a commercial environment. This equipment generates, uses and can radiate radio frequency energy and, if not installed and used in accordance with the instruction manual, may cause harmful interference to radio communications. Operation of this equipment in a residential area is likely to cause harmful interference in which case the user will be required to correct the interference at his own expense.

Note :

The use of shielded cables is required to comply within the limits of Part 15 of FCC rules and EN55022.

- * All the safety and operating instructions should be read before using this unit.
- * The safety and operating instructions manual should be retained for future reference.
- * All warnings on the equipment and in the documentation manuals should be adhered to.
- * All instructions for operating and use of this equipment must be followed precisely.

On Safety

1. This product should be operated from an AC power source.
This projector may be connected to an IT-power system.

Operating AC power voltage of the projector:

BARCOCINE 8 Art. No. R9002390/91/92 (230V AC)
BARCOCINE 8 Art. No. R9002397/98/99 (120V AC)

Consult your dealer to switch over from 230Vac to 120 Vac or from 120Vac to 230 Vac.
If you are not sure of the type of AC power available, consult your dealer or local power company.

2. This product is equipped with a 3-wire grounding plug, a plug having a third (grounding) pin. This plug will only fit into a grounding-type power outlet. This is a safety feature. If you are unable to insert the plug into the outlet, contact your electrician to replace your obsolete outlet. Do not defeat the purpose of the grounding-type plug.

WARNING FOR THE CUSTOMERS: THIS APPARATUS MUST BE GROUNDED (EARTHED) via the supplied 3 conductor AC power cable. (If the supplied power cable is not the correct one, consult your dealer.)

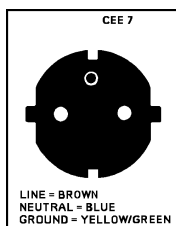

A. Mains lead (Power cord) with CEE 7 plug:

The wires of the mains lead are colored in accordance with the following code.

Green and yellow: earth (safety earth)
Blue: neutral
Brown: line (live)

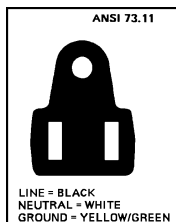

B. Power cord with ANSI 73.11 plug:

The wires of the power cord are colored in accordance with the following code.

Green/yellow: ground
White: neutral
Black: line (live)

3. Do not allow anything to rest on the power cord. Do not locate this product where persons will walk on the cord.
To disconnect the cord, pull it out by the plug. Never pull the cord itself.
4. If an extension cord is used with this product, make sure that the total of the ampere ratings on the products plugged into the extension cord does not exceed the extension cord ampere rating. Also make sure that the total of all products plugged into the wall outlet does not exceed 15 amperes.
5. Never push objects of any kind into this product through cabinet slots as they may touch dangerous voltage points or short out parts that could result in a risk of fire or electrical shock.

Never spill liquid of any kind on the product. Should any liquid or solid object fall into the cabinet, unplug the set and have it checked by qualified service personnel before resuming operations.

6. Lightning - For added protection for this video product during a lightning storm, or when it is left unattended and unused for long periods of time, unplug it from the wall outlet. This will prevent damage to the projector due to lightning and AC power-line surges.

On installation

1. Do not place this equipment on an unstable cart, stand, or table. The product may fall, causing serious damage to it.
2. Do not use this equipment near water.
3. Slots and openings in the cabinet and the back or bottom are provided for ventilation; to ensure reliable operation of the product and to protect it from overheating, these openings must not be blocked or covered. The openings should never be blocked by placing the product on a bed, sofa, rug, or other similar surface. This product should never be placed near or over a radiator or heat register.

The projector should not be placed in a built-in installation or enclosure unless proper ventilation is provided.

4. Do not block the projector cooling fans or free air movement under and around the projector. Loose papers or other objects may not be nearer to the projector than 4" on any side.

On servicing

Do not attempt to service this product yourself, as opening or removing covers may expose you to dangerous voltage potentials and risk of electric shock!

Refer all servicing to qualified service personnel.

Unplug this product from the wall outlet and refer servicing to qualified service personnel under the following conditions:

- a. When the power cord or plug is damaged or frayed.
- b. If liquid has been spilled into the equipment.
- c. If the product has been exposed to rain or water.
- d. If the product does not operate normally when the operating instructions are followed.
Note : Adjust only those controls that are covered by the operating instructions since improper adjustment of the other controls may result in damage and will often require extensive work by a qualified technician to restore the product to normal operation.
- e. If the product has been dropped or the cabinet has been damaged.
- f. If the product exhibits a distinct change in performance, indicating a need for service.

Replacement parts - When replacement parts are required, be sure the service technician has used original BARCO replacement parts or authorized replacement parts which have the same characteristics as the BARCO original part. Unauthorized substitutions may result in degraded performance and reliability, fire, electric shock or other hazards. Unauthorized substitutions may void warranty.

Safety check - Upon completion of any service or repairs to this projector, ask the service technician to perform safety checks to determine that the product is in proper operating condition.

On cleaning

Unplug this product from the wall outlet before cleaning. Do not use liquid cleaners or aerosol cleaners. Use a damp cloth for cleaning.

- To keep the cabinet looking brand-new, periodically clean it with a soft cloth. Stubborn stains may be removed with a cloth lightly dampened with mild detergent solution. Never use strong solvents, such as thinner or benzine, or abrasive cleaners, since these will damage the cabinet.
- To ensure the highest optical performance and resolution, the projection lenses are specially treated with an anti-reflective coating, therefore, avoid touching the lens. To remove dust on the lens, use a soft dry cloth. Do not use a damp cloth, detergent solution, or thinner.

On repacking

Save the original shipping carton and packing material; they will come in handy if you ever have to ship your equipment. For maximum protection, repack your set as it was originally packed at the factory.

On illumination

In order to obtain the best quality for the projected image, it is essential that the ambient light which is allowed to fall on the screen be kept to an absolute minimum.

When installing the projector and screen, care must be taken to avoid exposure to ambient light directly on the screen. Avoid adverse illumination on the screen from direct sunlight or fluorescent lighting fixtures.

Safety Instructions

The use of controlled ambient lighting, such as incandescent spot light or a dimmer, is recommended for proper room illumination. Where possible, care should also be taken to ensure that the floors and walls of the room in which the projector is to be installed are non-reflecting, dark surfaces. Brighter surfaces will tend to reflect and diffuse the ambient light and hence reduce the contrast of the projected image on the screen.

2

UNPACKING AND PROJECTOR DIMENSIONS

Projector Packaging

Way of Packaging

The projector is packed in a carton box.

To provide protection during transportation, the projector is surrounded with foam and enclosed within a sturdy fibreboard carton. The package is then secured with banding and fastening clips.

Unpacking

To open the banding around the carton, pull out the clip as shown below :

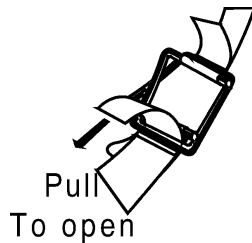

Take the projector out of its shipping carton and place it on a table.

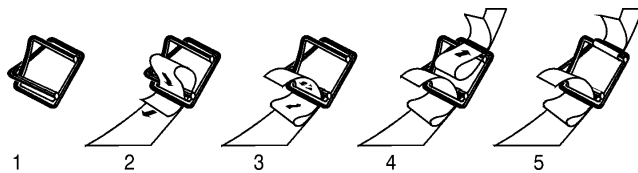

Hint

Save the original shipping carton and packing material, which will come in handy if you ever have to ship your projector. For maximum protection, repack your projector as it was originally packed at the factory.

Contents of the shipping carton :

- 1 BARCO CINE 8 projector
- 1 Remote Control Unit plus 2 x 1.5V batteries
- 1 Power cord with outlet plug type CEE7 or ANSI 73.11
- 1 Owner's Manual
- 1 Installation Manual
- 1 Iris3 adjustment manual

Projector dimensions (in mm)

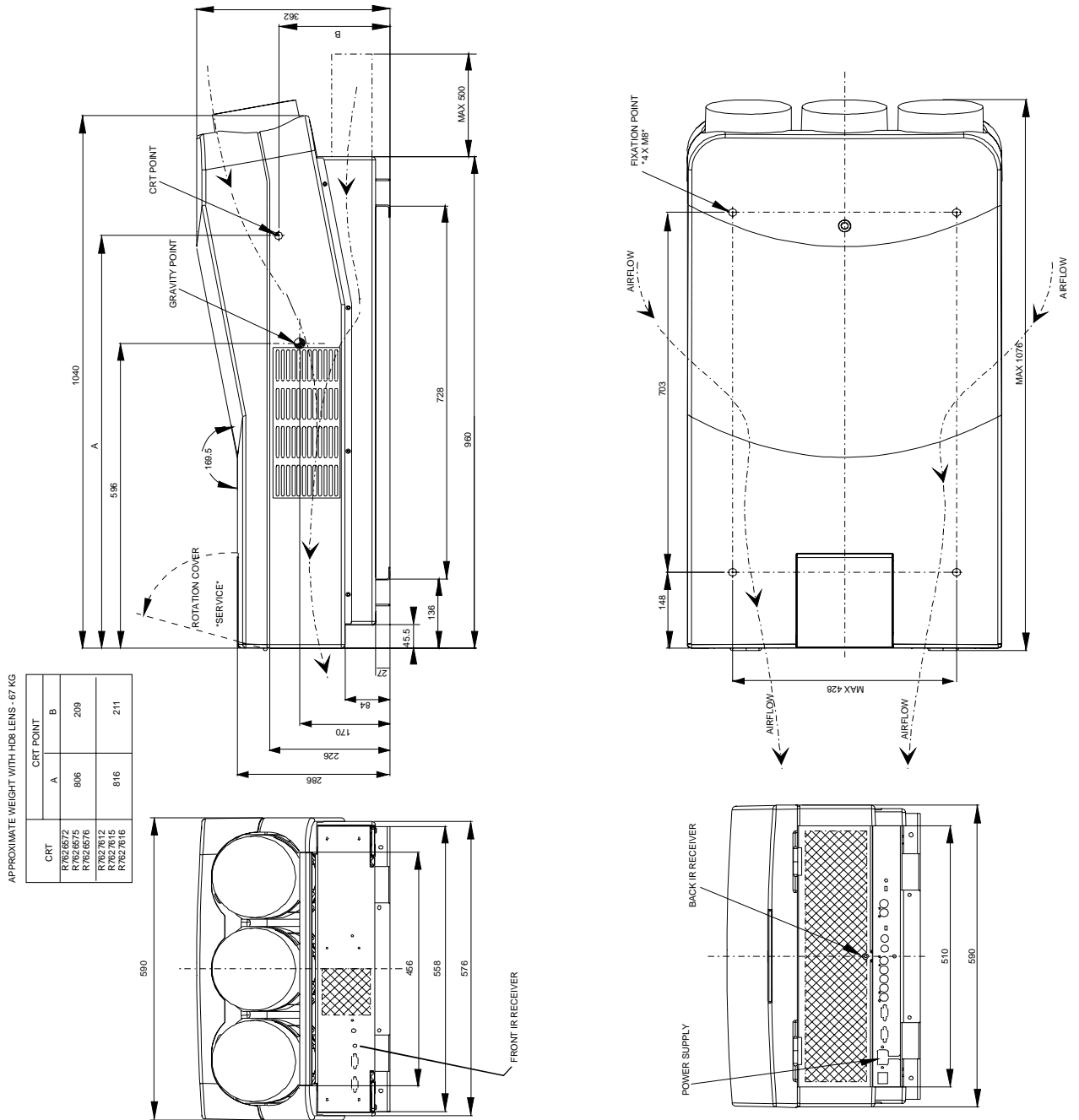

3

INSTALLATION GUIDELINES

Installation guidelines

Careful consideration of things such as image size, ambient light level, projector placement and type of screen to use are critical to optimize the use of the projection system.

Ambient Temperature Conditions

Operation temperature :

Max. ambient temperature : 40 °C (104°F)

Min. ambient temperature : 0 °C (32°F)

The projector will not operate if ambient air temperature falls outside this range (0°C - 40°C) (32°F - 104°F).

Storage temperature : -35°C to +65°C (-25.6°F to 149°F)

Humidity Conditions

Storage : 0 - 98 % RH Non-condensing

Operation : 0 - 95 % RH Non-condensing

Environment

Do not install the projection system in a site near heat sources such as radiators or air ducts, or in a place subject to direct sunlight, excessive dust or humidity. Be aware that room heat rises to the ceiling; Make sure the temperature near the installation site is not excessive.

What about ambient light ?

The ambient light level of any room is made up of direct or indirect sunlight and the light fixtures in the room. The amount of ambient light will determine how bright the image will appear. So, avoid direct light on the screen as much as possible.

Windows that face the screen should be covered by opaque drapery while the set is being viewed. It is desirable to install the projecting system in a room whose walls and floor are of non-reflecting material. The use of recessed ceiling lights and a method of dimming those lights to an acceptable level is also important. Too much ambient light results in a 'wash out' of the projected image. This appears as less contrast between the darkest and lightest parts of the image. With bigger screens, the 'wash out' becomes more important. As a general rule, darken the room to the point where there is just sufficient light to read or write comfortably. Spot lighting is desirable for illuminating small areas so that interference with the screen is minimal.

Which screen type?

There are two major categories of screens used for projection equipment. Those used for front projected images and those for rear projection applications.

Screens are rated by how much light they reflect (or transmit in case of rear projection systems) given a determined amount of light projected toward them. The 'GAIN' of a screen is the term used. Front and rear screens are both rated in terms of gain. The gain of screens range from a white matte screen with a gain of 1 (x1) to a brushed aluminized screen with a gain of 10 (x10) or more. Another important consideration is the degree the screen's gain varies with the horizontal and vertical viewing angle. The choice between higher and lower gain screens is largely a matter of personal preference.

In considering the type of screen to choose, determine where the viewers will be located and go for the highest gain screen possible. A high gain screen will provide a brighter picture but reduce the viewing angle.

For more information about screens, contact your local screen supplier.

What image size? How big should the image be?

The projector is designed for projecting an image width from 1.4m (4.6') to 6m (20') with an aspect ratio of 4 to 3. It leaves the BARCO factory, adjusted as a ceiling/front projector for a screen width of 2.4m (7.8'). Changing the image size from the factory preset size requires a realignment of the projector.

Where to install the projector ?

To indicate a correct installation position it is necessary to know :

- The distance from projector to ceiling in case of Ceiling mounted or the distance from projector to floor in case of Table mounted;
- The distance from projector to screen.

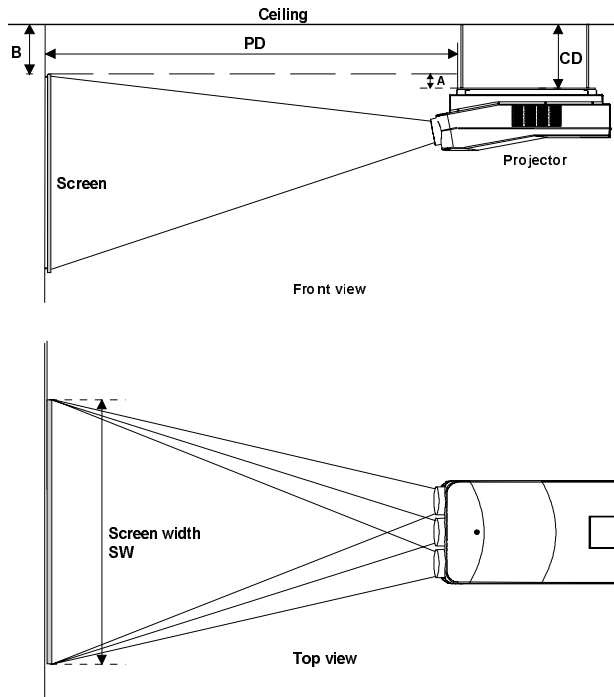

- Install the projector water levelled in both directions
- Install the projector perpendicular to the screen

To find the correct position for the BARCO CINE8, equipped with HD8 lenses, use the following formulas:

$$PD[m] = 1.269 \times SW[m] + 0.344$$

$$A[cm] = 12 \times SW[m] - 28.2$$

$$PD[inch] = 1.269 \times SW[inch] + 13.54$$

$$A[inch] = 0.12 \times SW[inch] - 11.11$$

Abbreviations used in the calculations and the drawings :

B = Distance between ceiling and top of the screen (Ceiling mounted) or distance between floor and bottom of the screen (Table mounted).

A = Correction Value, extra value to be added to B to obtain the correct installation position (In some cases the A value can be negative).

CD = Total distance between projector and ceiling (Ceiling mounted) or total distance between projector and floor (Table mounted).
 $CD = A + B$.

Ceiling Mounted : when the result is negative, enlarge the distance between ceiling and top of the screen, mount screen lower, until CD becomes zero or positive.

Table Mounted : when the result is negative, enlarge the distance between floor and bottom of the screen, mount screen higher, until CD becomes zero or positive.

SW = Screen width.

PD = Perpendicular distance between screen and projector's mount.

To obtain the right values, you can make use of the option included in the Installation Adjustment Mode to let the projector calculate the parameters automatically. Please refer to Chapter 8 for details.

Used phosphor width on the CRT faceplate (e.g. green CRT)

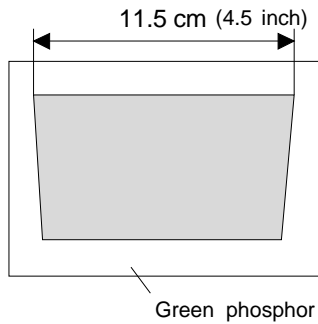

Scan Adaptations

Access to Scan Controls

Opening the top cover

During the projector setup and installation it is necessary to open the top cover. Follow the procedure described below :

- Turn the locking screw with a screwdriver counter clockwise;
- Lift up and pivot the top cover.



WARNING

The projector's top cover is **not** supported with locking hinge. Open with care and support the cover with your hand.

Removing the top cover

During some installations, it will be convenient to remove the top cover from the projector totally.

Proceed as follows :

- Pivot the top cover backwards 90° (fully extended);
- Push carefully the top cover to the left side (viewing from the rear of the projector) until the hinges are disengaged. This can be facilitated by pressing downwards on the spring tabs next to the hinges. Slide the top cover off the projector.

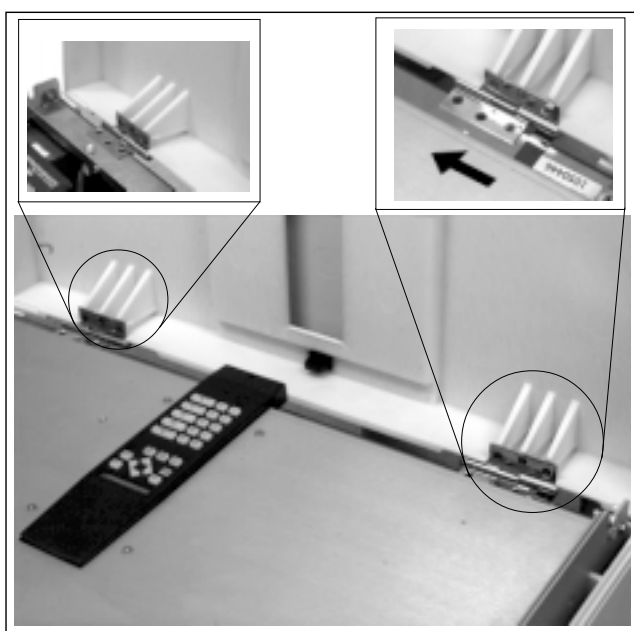
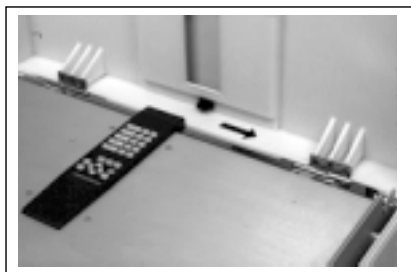

Reinstalling the top cover

To reinstall the top cover on the projector :

- Place the top cover in front of the hinges (as shown in the picture) and push in the direction of the black arrow until the cover locks into the hinges;
- Pivot the top cover to close;
- Secure the locking screw by turning it clockwise with a screwdriver.

Scan Inversion

What has to be done ?

The scan switches must be placed in the correct position which corresponds to the desired scanning configuration. To change the scanning, it is necessary to remove the projector top cover and to open the protection plate. For opening the projector's top cover, see 'Access to controls'. Turn off the projector and unplug the power cord before changing the scan direction.

Getting access to the scan switches

- Open the top cover and remove it from the projector;
- Loosen the 3 retaining screws on each side of the projector;
- Open the protection plate and pivot it forward (toward lenses).

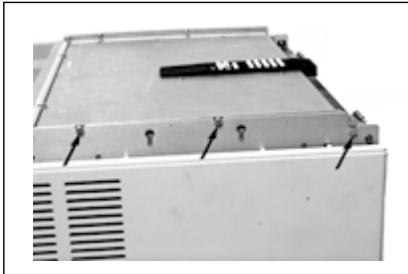

Horizontal Scan Switches

Three switches are used, one for each CRT. When changing the horizontal scan, insure that all three switches are set in the same position. See positions of the switches (diagram on next page) for the corresponding projector configuration.

To set the scan switches :

- Remove the horizontal deflection module (the second module viewing from the rear of the projector).
To remove the horizontal deflection module :
 - Press the module lock and lift up the module handle;
 - Repeat this action on both sides of the module and extract the module out of the main frame.
- Toggle the 3 horizontal scan inversion switches (located just underneath the horizontal amplitude module) to the correct positions.
- Reinstall the horizontal deflection module.

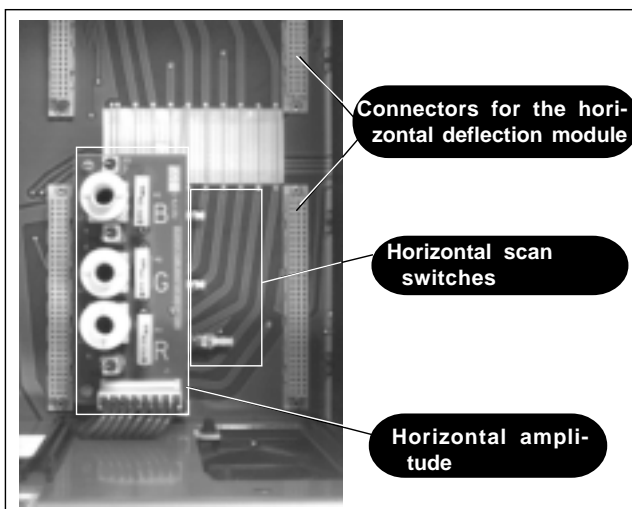
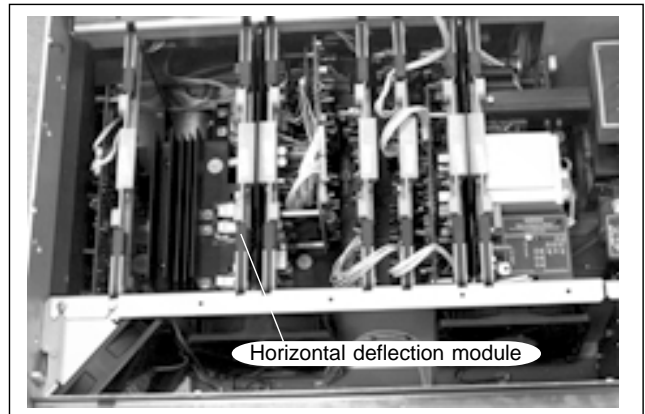
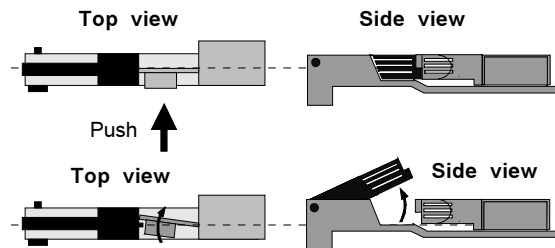

Vertical Scan Switch

One vertical switch is used for the three CRT's. See position of the switch (diagrams) for the corresponding projector configuration.

To set the vertical scan switch :

- Remove the vertical deflection module (the third module viewing from the rear of the projector).
To remove the vertical deflection module :
 - Press the module lock and lift up the module handle;
 - Repeat this action on both sides of the module and extract the module out of the main frame.
- Toggle the vertical scan inversion switch to the correct position.
- Reinstall the vertical deflection module.

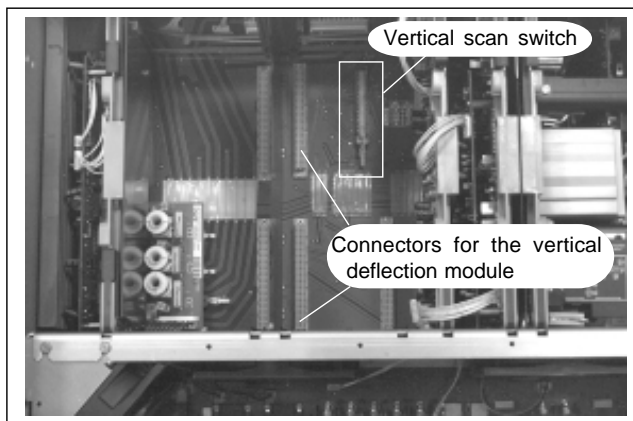
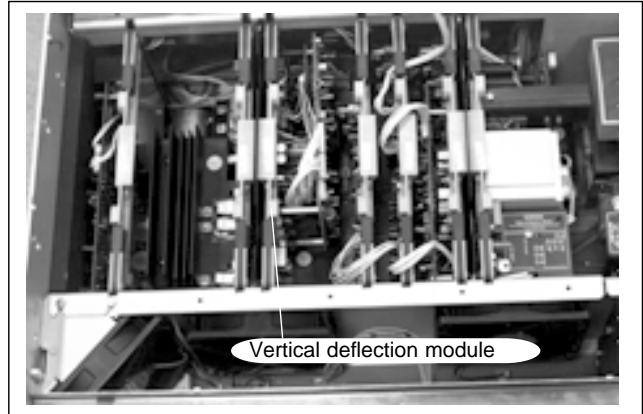
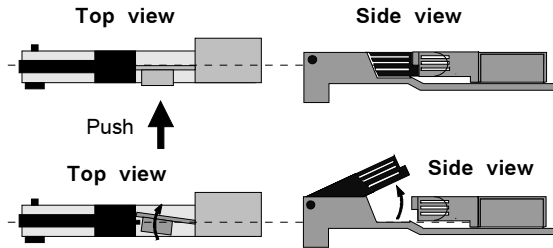

Positioning the scan switches for the different mounting configurations

Positions of the scan switches for the different mounting configurations are illustrated below.

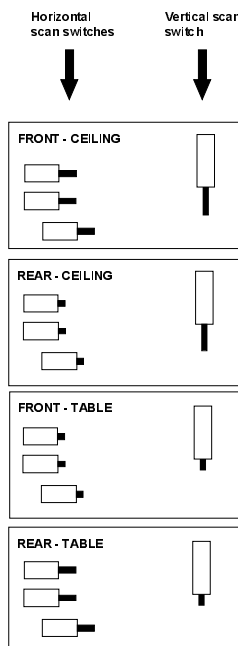

Note

After setting the scan switches, close the metal protection plate and secure it with the retaining screws.

Close the top cover and reconnect the power cord to the wall outlet.

Switching over from Floor to Ceiling or vice versa requires a complete readjustment of picture geometry and convergence.

Check Procedure

To check the current positions of the scan switches, proceed as follows:

Attention : This procedure can only be done after power (mains) connection. So, first continue with the projector setup and the connections and then return to this procedure.

- Switch on the projector. The projector starts up on the last selected source.
- Press the **ADJUST** to start up the adjustment mode (menu 1).
- Push the cursor key \hat{e} or \acute{e} to select Service.
- Press the **ENTER**. The 'SERVICE MODE MENU' will be displayed (menu 2).
- Push the cursor key \hat{e} or \acute{e} to select Identification.
- Press the **ENTER**. The identification screen will be displayed (menu 3).

This screen gives the current information about the projector configuration in the line entitled 'Config'.
All projectors leave the factory set for a ceiling/front configuration.

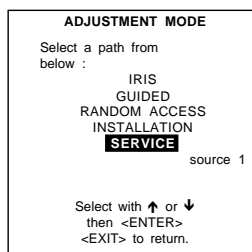

menu1

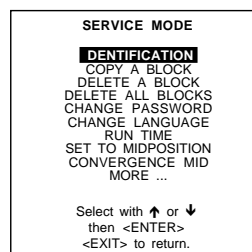

menu2



menu2

Setting the projector address

The projector's address may be set to any value between 0 and 255.

When the address is set, the projector can be controlled now by :

- RCU for addresses between 0 and 9.
- IBM PC (or compatible) or Apple MAC for addresses between 0 and 255.

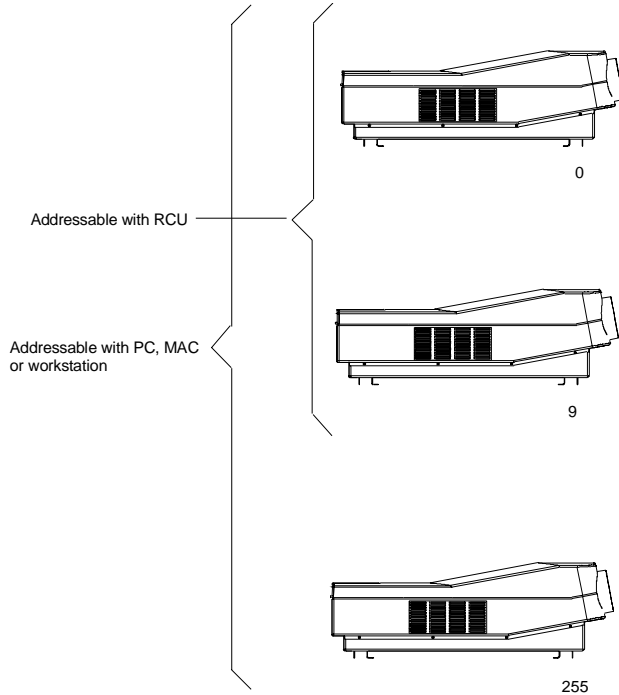

Setting the address is a hardware SETUP of your projector which must be done during installation. Use the 8 DIP switches provided on the controller board labelled 'Projector Address'.

Each DIP switch has its own decimal value. The sum of the values associated to those DIP switches gives the address. As shown in the table, if Switch No. 1 is set to ON, it represents a decimal value of 128, Switch No.2 for 64, Switch No.3 for 32, and so forth.

In the given example, the projector address is set to 202 :

DIP switch No. : 1 2 3 4 5 6 7 8
 Position ON/OFF : 1 1 0 0 1 0 1 0

$$\text{Sum} : 1 \times 128 + 1 \times 64 + 0 \times 32 + 0 \times 16 + 1 \times 8 + 0 \times 4 + 1 \times 2 + 0 \times 1 = 202$$

Factory preset address = 0

Note :

Switch No	Value
1	128
2	64
3	32
4	16
5	8
6	4
7	2
8	1

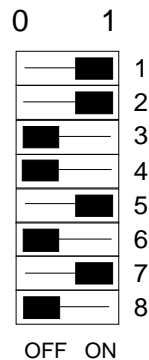

When the address button on the RCU is pressed, the projector will display its own address on the screen. Once the address button is pressed, to continue using your RCU, it is necessary to enter an address, even when the displayed address is correct. Use the numeric keys to enter the address.

For more information, please refer to the projector Owner's Manual .

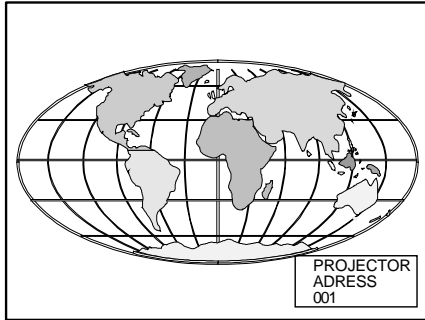

Powerup mode

The projector can start up in two different modes. The start-up mode is determined by the position of DIP Switch No. 4 of another set of 8 DIP switches on the controller board (one set of 8 switches are used for projector address setting).

Position of the DIP Switch No. 4 (powerup mode) :

- ON : operational mode.
- OFF: standby mode (Factory preset).

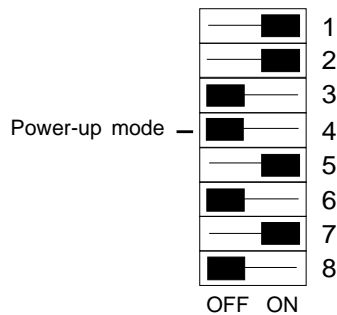

Operational mode

When the power switch on the rear of the projector is pressed, the projector displays the last selected source if available, otherwise it remains on that source number until the source becomes available.

The on screen indication is only available when the "Text" function is set to "ON".

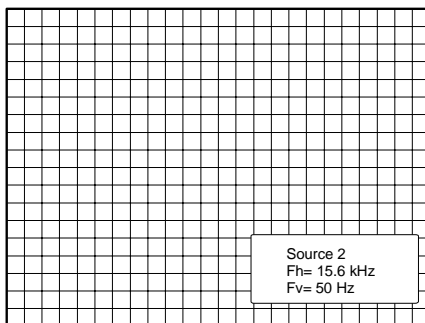

Standby mode

When the power switch on the rear of the projector is pressed, the projector starts up in the standby mode. The standby key on the RCU is used to turn the projector ON and OFF.

Baud Rate for communication with a computer

The communication speed between the projector and the computer has 8 possible settings. With DIP Switch No. 6, No.7 and No.8 of the 8 DIP switches on the controller board, labelled as 'Baud rate code (sum)', it is possible to select the baud rate (communication speed). Each DIP switch has its own decimal value. The sum of the values associated to those DIP switches gives the baud rate code. Each baud rate code corresponds an communication speed.

Position of DIP switches and baud rate codes :

Binary	Baud rate code	Speed
000	0	110
001	1	150
010	2	300
011	3	600
100	4	1200
101	5	2400
110	6	4800
111	7	9600

Factory preset baud rate = 9600

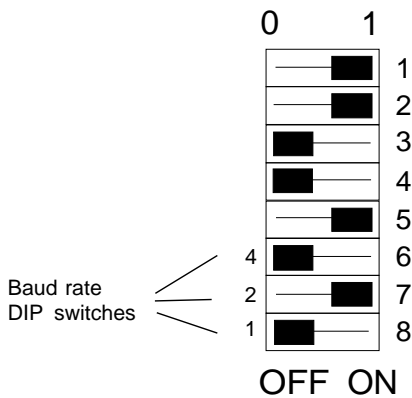

More information about computer communication with the projector is available in the Projector Control Software manual.

Password mode

With DIP Switch No.5 of the second set of 8 DIP switches on the controller board, the projector adjustments can be protected with a password. When the password feature is enabled, the user has to enter a password before he can enter the adjustment mode (For more information about password setting and reprogramming the password, see Installation Adjustment).

When the password menus are disabled (adjust mode is unprotected), the adjust mode can be selected by pressing the <ADJUST> key. This position of the DIP switch is useful for qualified service technicians because they do not need a password to enter the adjust mode.

Position of DIP Switch No.5 :

- ON : password mode enabled.
- OFF : password mode disabled.

Factory preset password mode : OFF.

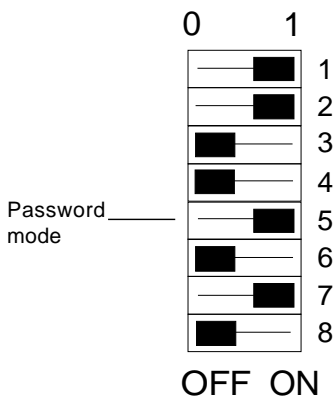

5

AC POWER CONNECTION

Power Connection

AC Power (mains) cord connection

Use the supplied cord to connect your projector to the wall outlet. Plug the female power connector into the male connector at the back of the projector.

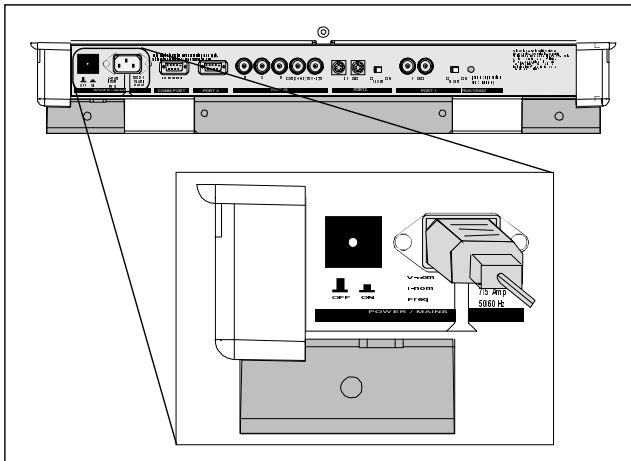
**Preparing your power cord****Mains lead (power cord) with CEE7 plug**

As the colors of the wires in the mains lead of this apparatus may not correspond with the colored markings identifying the terminals in your plug, proceed as follows:

- The yellow/green wire is ground and must be connected to the terminal in the plug which is marked by the letter E or by the safety earth symbol or colored yellow and green.
- The blue wire is neutral and must be connected to the terminal marked with the letter N or colored black.
- The brown wire is the line and must be connected to the terminal marked with the letter L or colored red.

The wires of the delivered mains lead (power cord) are colored in accordance with the following code :

Yellow and Green	:	Ground (Earth).
Blue	:	Neutral.
Brown	:	Live.

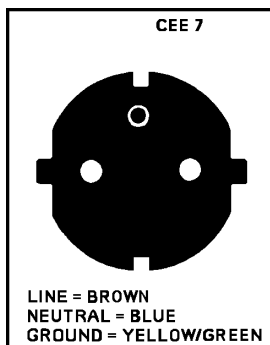

Power cord with an ANSI 73.11 plug

The wires of the delivered mains lead (power cord) are colored in accordance with the following code :

Yellow and Green	:	Ground (Earth).
White	:	Neutral.
Black	:	Live.

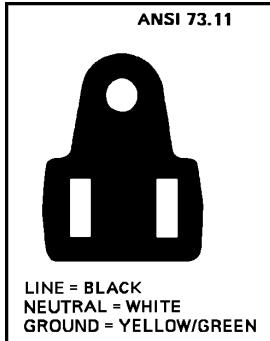

AC Power check

Check the power voltage which is determined by the ART. NR. (Article number) included in the label pasted on the backside of the projector.

Projectors with the ART. NR. R9002390, R9002391 or R9002392 must be connected to a 230 VAC power source.
Projectors with the ART. NR. R9002397, R9002398 or R9002399 must be connected to a 120 VAC power source.

If the indicated voltage is different from that of the wall outlet, call a qualified technician for power adaptation of the projector.

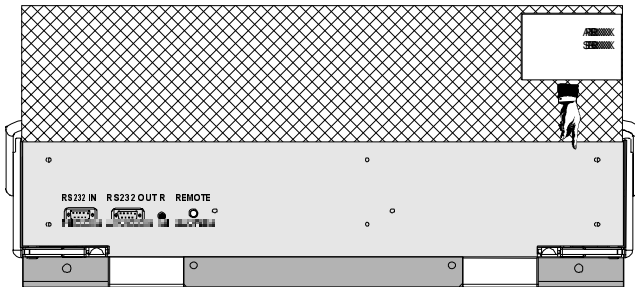

AC Input power (mains) voltage adaptation

Adaptation of the power input of the projector between 230 Vac and 120Vac or vice versa is possible.

Follow the procedure as described below to adapt the voltage :

- 1 WARNING: turn off the projector and be sure the AC Power Cord is unplugged before starting the procedure !**
- 2 Open the top cover (see 'Access to controls' in chapter Installation Guidelines).
- 3 Unscrew the retaining screws of the AC power input board and remove this board.
- 4 Pull out the 'Power selector plug' (Photo 2) and reinsert it as illustrated in Photo 3, depending on the AC power of the wall outlet in the room.
- 5 Pull out the fuses and place the correct fuses in their sockets. See the table below for the correct type of fuses.
- 6 Reinsert the power input board and secure it with the retaining screws.

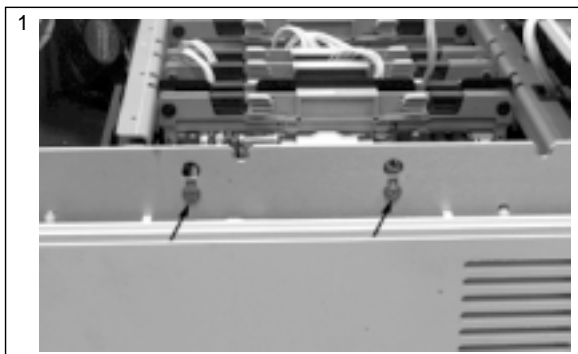

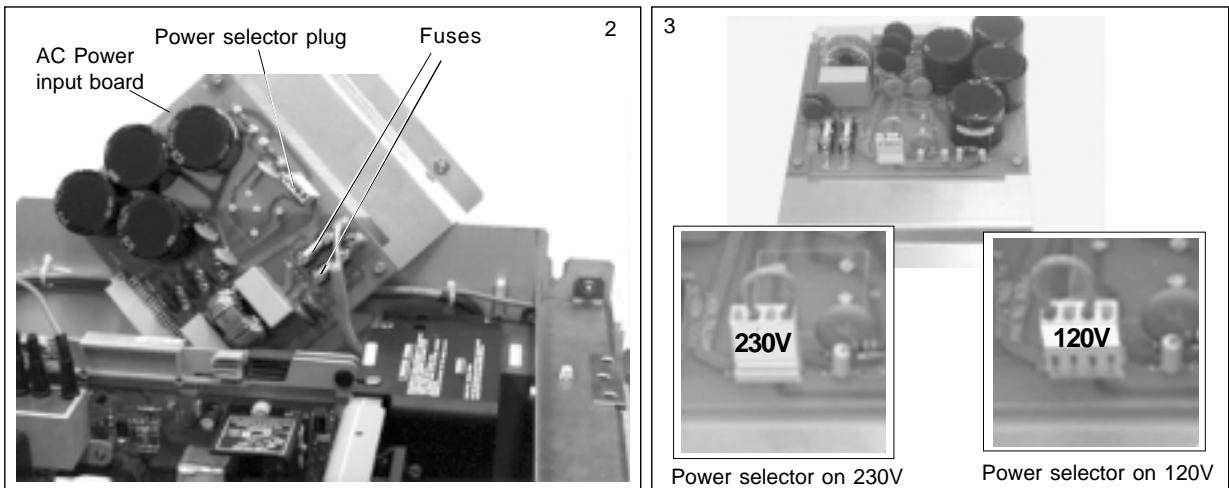

Fuses

Warning !

For continued protection against fire hazard :

- Replace with the same type of fuse.
- Refer replacement to qualified service personnel.

AC power	Fuses	Order Number
230 Vac	T6.3A/250V (2x)	R314145
120 Vac	T10A/250V (2x)	R314154

Switching on

The projector is switched ON using the power (mains) switch ON/OFF.

Pressed : ON state

Not pressed : OFF state

The projector can start now in :

- Operational mode (picture displayed)
- Stand by mode

Depending on the position of the 'Power up' dip switch on the controller unit. This DIP switch is set during installation by a qualified technician. If you want to change this start up mode, call a qualified technician.

Start up in Operational Mode

The projector can start up with the selected source or the projector can start up with a warm up cycle message (menu 1).

```

PROJECTOR WARM UP
A FULL WHITE PATTERN WILL BE
GENERATED FOR 20 MIN.
FOR IMMEDIATE USE OF THE
PROJECTOR, PRESS <EXIT>
WARNING : SKIPPING THIS
PROCEDURE CAN REDUCE THE
INITIAL PICTURE QUALITY OF THE
PROJECTED IMAGE.
YOU CAN ADJUST THE IMAGE
DIMENSIONS WITH THE ARROW
KEYS TO AVOID SCANNING ON
THE EDGES OF THE CRT'S.
THIS OPTION CAN BE DISABLED IN
THE SERVICE MENU

with <ENTER>
<EXIT> to return

```

menu 1

When this warm up cycle message appears on the screen, the menu offers the possibility to start with this 20 minutes taking warm up periode (press ENTER) or to skip this cycle (press EXIT).

Note : This warm up periode is built in so that the projector can reach its maximum specifications and minimize all distortions.

When starting this warm up period, a full white image is shifted on the CRT faceplate to avoid a burn in. Every 30 seconds a text box will be displayed on another place on the screen with the remaining time to go.

To interrupt the warm up period, handle as follow :

- 1 Press EXIT, the warm up menu will be redisplayed with the remaining time indication.
- 2 Press EXIT again to quit the warm up cycle and to display the source.

Start up in Stand by Mode

The projector starts up in stand by.

Press a digit key corresponding to the desired source or press STBY key.
The projector displays the selected source or the warm up cycle message.

When this warm up message appears on the screen, handle as described in 'Start up in Operational Mode'.

Start up with "Warm up period"

If no action is taken, a white image will be displayed for 20 minutes.
This white image will be shifted on the faceplate of the CRT to avoid CRT burn-in.

During this warm up period, it is possible to interrupt this white image projection by pressing the <EXIT> key. The "Projector warm

6

SOURCE CONNECTIONS

Input Source Connection

Input facilities

- Composite Video (*)
- S-Video (*)
- RGBS or RGsB (*)
- RGB3S or RG3sB
- (R-Y)Y(B-Y)S or (R-Y)Ys(B-Y) [component input] (**)
- (R-Y)Y(B-Y)3S or (R-Y)Y3s(B-Y) [component input] (**)

(*) If the line double or line multiplier feature is built in, this feature is available via a software on/off toggle.

(**) If the line double or line multiplier feature is built in, this feature is available for component video signals on standard frequency via software on/off toggle.

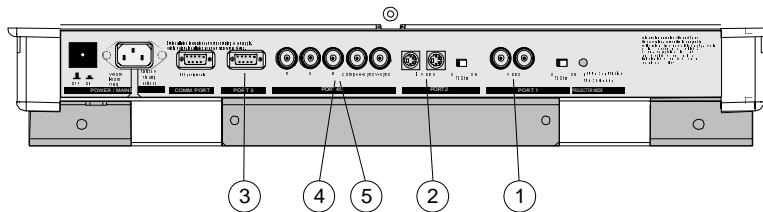
Which source to which input

Source No	Projector input	Press digit button
1	Comp. Video	1
2	S-Video ¹ /Comp. Video*	2
3	RGB ²	3
4/5	RGB ²	4 or 5
4/5	Component video ³	6
4/5	RGB with Tri level sync ⁴	7
4/5	Component video with Tri-level sync ⁵	8

¹ Input signal Y/C (luma/chroma)

² Input signal : R, G and B with automatic sync detection between separate sync (separate composite sync or with separate Hor and Vert. sync) or sync on green (composite sync).

³ Input signal : R-Y, Y and B-Y with separate composite sync or with separate Hor and Vert. sync or with composite sync on Y.

⁴ Input signal : R, G and B with separate Tri level sync or with Tri-level sync on green (optional).

⁵ Input signal : R-Y, Y and B-Y with separate Tri level sync or with composite Tri-level sync (optional).

* Video or S-Video : switchable in the Picture Tuning menu.

Connecting a Composite Video source.

Composite video signals from a VCR, OFF air signal decoder, etc..

Note :

If a line doubler or line multiplier is built in, the default position of this line doubler (multiplier) soft option is ON (active). The video input signal will be displayed as a non interlaced image (= improved image stability). To enable or to disable this function, enter the adjustment mode and change the position of the ON/OFF toggle switch (see chapter 'Random access' adjustment mode).

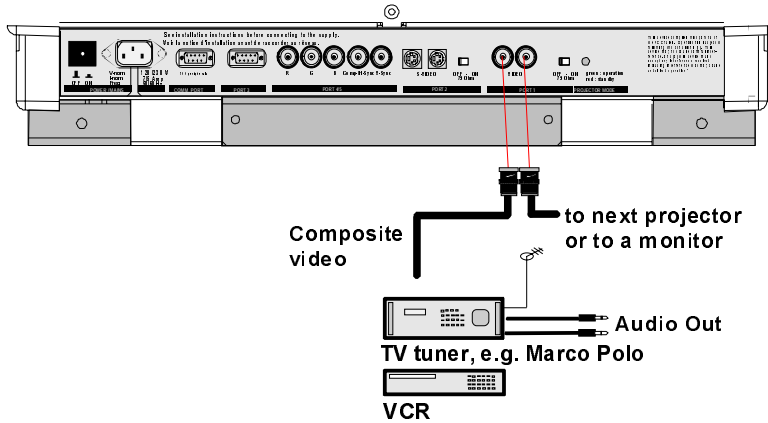

Video input selection :

With the RCU or built-in RCU : press digit button 1

Note

When using the loop-through Video output, then set the termination switch to the 'OFF' position.

75 Ω Termination Switch for Video

Terminate the video input of the projector using the 75 Ω switch next to the video input, when the projector operates alone or when the projector is the last unit in loop-through configuration.

The switch is set to 'ON' : signal terminated
 The switch is set to 'OFF' : signal not terminated.

Connecting a S-Video or Video source to port 2.

Separate Y-luma/C-chroma signals for higher quality playback of Super VHS signals.

Note :

If a line doubler or line multiplier is built in, the default position of this line doubler (multiplier) soft option is ON (active). The video input signal will be displayed as a non interlaced image (= improved image stability). To enable or to disable this function, enter the adjustment mode and change the position of the ON/OFF toggle switch (see chapter 'Random access' adjustment mode).

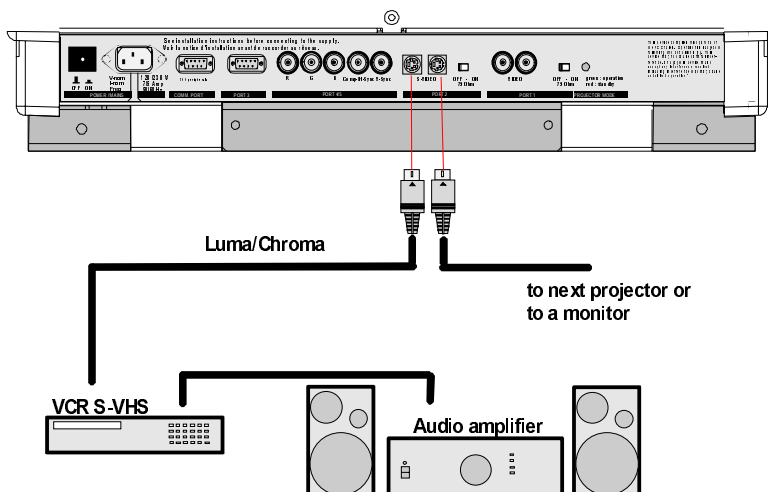

Pin configuration 4 pin connector

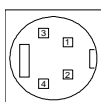

For S-video:

Pin 1: earth(ground) luminance
 Pin 2: earth(ground) chrominance
 Pin 3: luminance signal(Y)
 1Vpp \pm 3dB
 Pin 4: chrominance signal(C)
 300mVpp \pm 3dB

For video:

Pin 1: earth(ground) video
 Pin 2: not connected
 Pin 3: video signal
 Pin 4: not connected

Input selection

With the RCU or built-in RCU : press digit button 2

Input Priority setting

Depending on the priority setting in the 'Picture Tuning menu', Video or S-Video can be displayed.

If the setting is not correct, handle as follow :

- 1 Press **ADJUST** key to start up the adjustment mode. The main menu will be displayed (menu 1).
- 2 Select 'Service Menus'.
- 3 Press **ENTER** to select.
A warning menu, 'risk of incorrect adjustment', will be displayed (menu 2).
- 4 Press **ENTER** to continue if you are qualified, or **EXIT** if not.
When **ENTER** is pressed, the 'Adjustment main menu' will be displayed (menu 3).
- 5 Select 'Random Access'.
- 6 Press **ENTER** to select.
The 'Choose a setup pattern menu' will be displayed (menu 4).
- 7 Select 'Selected source'.
- 8 Press **ENTER** to display the 'Random Access' menu (menu 5).
- 9 Select 'Picture Tuning'.
- 10 Press **ENTER** to display the picture tuning menu (menu 6).
- 11 Select 'Port2 : Video'.
- 12 Press **ENTER** to toggle between VIDEO or S-VIDEO.
- 13 Press **ADJUST** to return to operational mode.

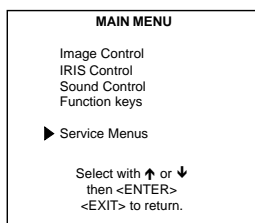

menu 1

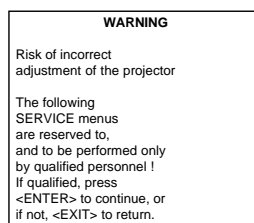

menu 2

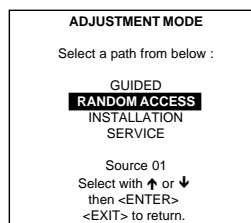

menu 3

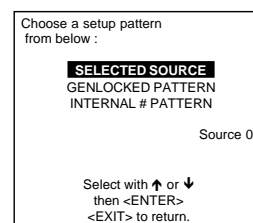

menu 4

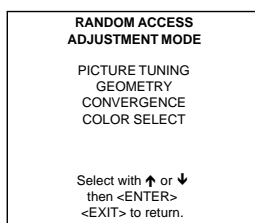

menu 5

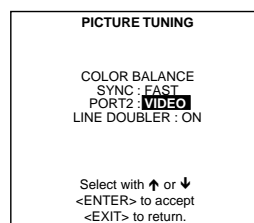

menu 6

Note

When using the Port 2 loop-through output, set the Termination switch in the 'OFF' position.

75 Ω Termination Switch for Video

Terminate the video input of the projector using the 75 Ω switch next to the video input, when the projector operates alone or when the projector is the last unit in loop-through configuration.

The switch is set to 'ON' : signal terminated

The switch is set to 'OFF' : signal not terminated.

Connecting a RGB Analog source to port 3

Connect your RGB source via an interface to Port 3.

Note :

If a line doubler or line multiplier is built in, the default position of this line doubler (multiplier) soft option is ON (active). The video input signal will be displayed as a non interlaced image (= improved image stability).

To enable or to disable this function, enter the adjustment mode and change the position of the ON/OFF toggle switch (see chapter 'Random access' adjustment mode).

Always use an interface when a computer and local monitor have to be connected to the projector.

BARCO's Interface units.

Universal analog interface	R9826100
RGB 120 MHz Analog Interface	R9826570 (230V)
Multifunctional Analog Interface Kit (MAGIK)	R9828120 (230V)
VGA interface	R9828129 (120V)
	R9828070 (230V)
	R9828079 (120V)
MAC interface	R9828050 (230V)
	R9828059 (120V)

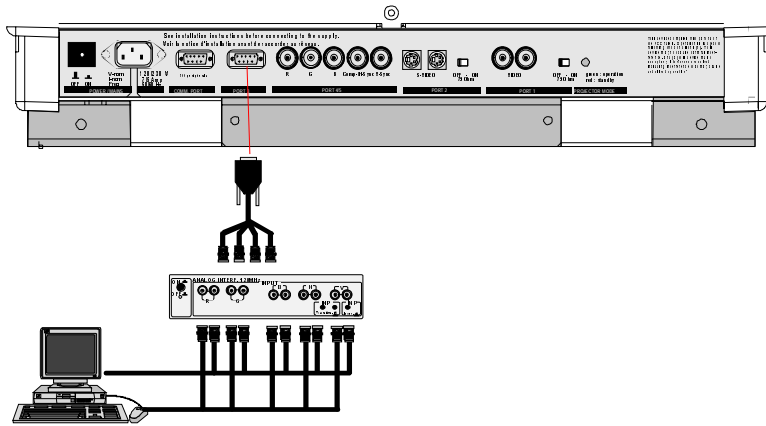

Pin configuration D9 connector of the Analog input.

- 1 Not connected
- 2 Ground RGBS
- 3 RED
- 4 GREEN
- 5 BLUE
- 6 Ground RGBS
- 7 Ground RGBS
- 8 Hor/comp. sync
- 9 Vert. sync

Input selection

With the RCU or built-in RCU : press digit button 3

Locations of the Termination Resistors and Switches on the RGB Input Auto Sync Tracking Module

When changing a switch position or removing a resistor, turn off the projector and unplug the power cord from the wall outlet.

75 Ω Termination resistors

In case of chaining (loop-through) the projectors, the 75Ω line termination resistors must be removed from the RGB Input Auto Sync Tracking Module when the projector is NOT the last unit in the chain.

In case of a stand-alone projector, do not remove the resistors.

75 Ω resistors on the module : line terminated.
 75 Ω resistors removed : line not terminated.

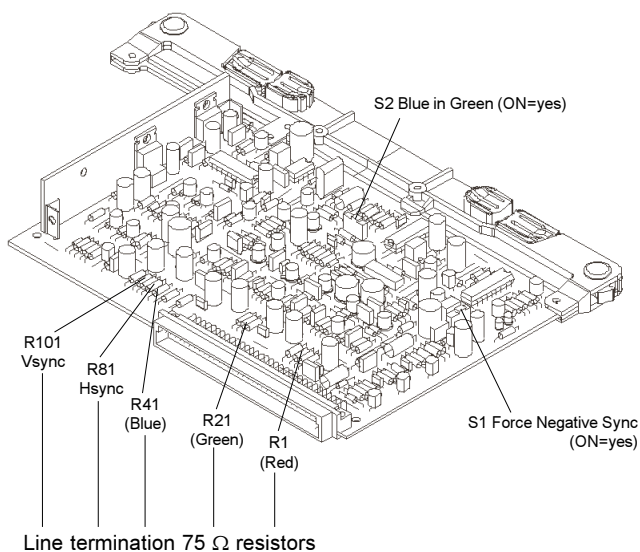

Procedure to remove the line termination resistors :

- 1 Turn off the projector and unplug the projector power cord.
- 2 Remove the top cover from the projector (see p.4-1).
- 3 Remove the RGB Input Auto Sync Tracking Module from the main frame.
- 4 Unsolder and remove the resistors.

To remove the RGB Input Auto Sync Tracking Module, follow the same procedure as described in chapter Installation Guidelines for removing the Horizontal Deflection module :

- 1 Press the module lock and lift up the module handle;
- 2 Repeat this action on both sides of the module and extract the module out of the main frame.

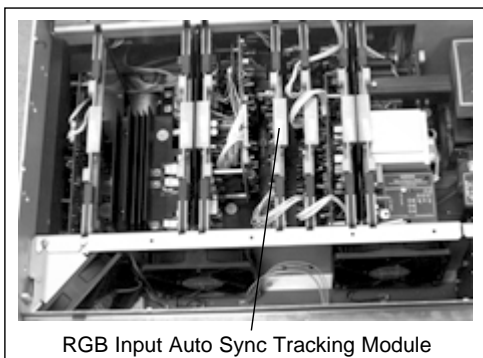

Blue in Green Switch on the RGB Input Auto Sync Tracking Module

Blue characters are difficult to read, therefore the blue text will be displayed as cyan so that the readability becomes better.

Switch in the ON position : Blue in Green active.
 Switch in the OFF position : Blue in Green disabled.

WARNING : Leaving the switch in the ON position will result in abnormal color balance of the projected image.

Force Negative Sync on the RGB Input Auto Sync Tracking Module

Switch in the ON position : the sync pulses must be negative.
 Switch in the OFF position : the sync polarity will be automatically detected.

Connecting a RGB Analog source with composite sync to port 4/5.

RGB analog input terminals with separate H and V sync inputs, composite sync input or with sync on green. The projector detects automatically where the sync signal is located.

Note :

If a line doubler or line multiplier is built in, the default position of this line doubler (multiplier) soft option is ON (active). The video input signal will be displayed as a non interlaced image (= improved image stability).

To enable or to disable this function, enter the adjustment mode and change the position of the ON/OFF toggle switch (see chapter 'Random access' adjustment mode).

Always use an interface when a computer and local monitor have to be connected to the projector.
(see Connecting an Analog source to Port 3).

RGBS or RGsB input selection

With the RCU or built-in RCU : press digit button 4 or 5

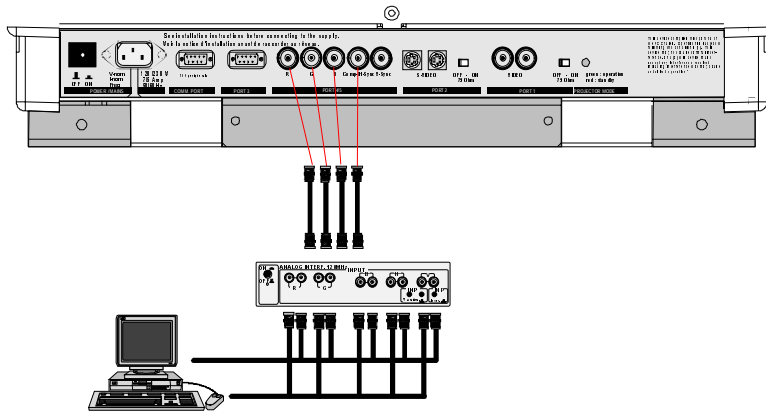

Connecting a RGB Analog source with Tri-level sync.

RGB analog input terminals with Tri level sync input or with Tri-level sync on green. The projector detects automatically where the sync signal is located.

RGB3S or RG3sB input selection

With the RCU or built-in RCU : press digit button 7

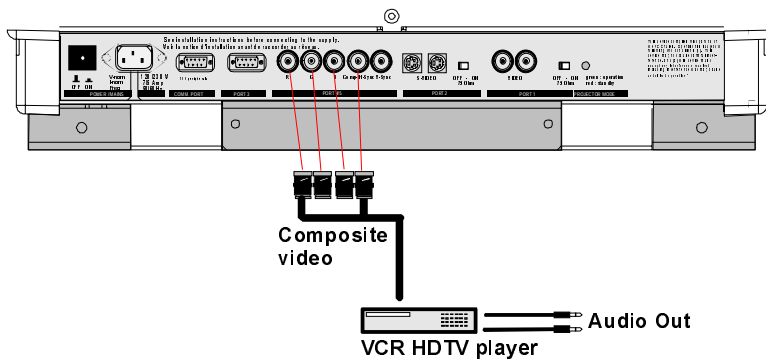

Connecting a Component source.

(R-Y)Y(B-Y) analog input terminals with sync input or with sync on the luminance (Y) input. The projector detects automatically where the sync signal is located.

Line doubling or multipling is possible for component video input sources on standard line frequency.

Note :

If a line doubler or line multiplier is built in, the default position of this line doubler (multiplier) soft option is ON (active). The video input signal will be displayed as a non interlaced image (= improved image stability).

To enable or to disable this function, enter the adjustment mode and change the position of the ON/OFF toggle switch (see chapter 'Random access' adjustment mode).

(R-Y)Y(B-Y)S or (R-Y)Ys(B-Y) input selection (component video input)

With the RCU or built-in RCU : press digit button 6

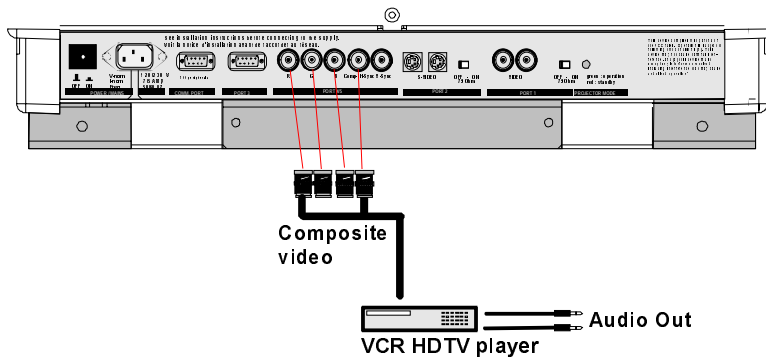

Connecting a Component source with Tri-level sync.

(R-Y)Y(B-Y) analog input terminals with Tri-level sync input or with Tri-level sync on the luminance input.

(R-Y)Y(B-Y)3S or (R-Y)Y3s(B-Y) input selection

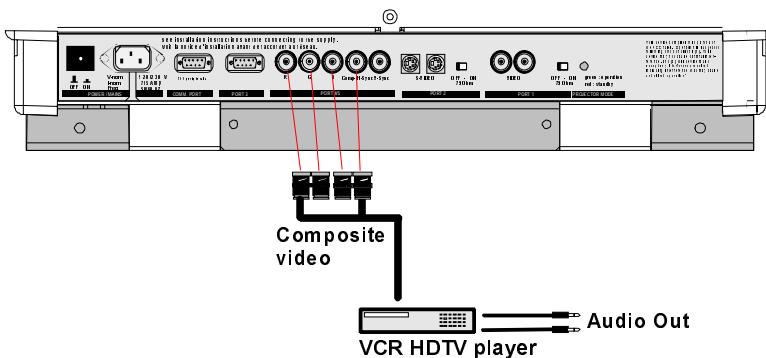

RS232 Connection

RS232 input and RS232 output of the projector.

The projector is equipped with a RS232 port that allows it to communicate with a computer.

Applications

- a) remote control:
 - easy adjustment of the projector via IBM PC (or compatible) or MAC connection.
 - allow storage of multiple projector configurations and set ups.
 - wide range of control possibilities.
 - address range from 0 to 255.
- b) data communications:
 - sending data to the projector or copying the data from the projector to a hard memory device.

Set up of the Baud Rate for Communication with a Computer.

See 'Change Baudrate PC' in chapter 'Service mode'

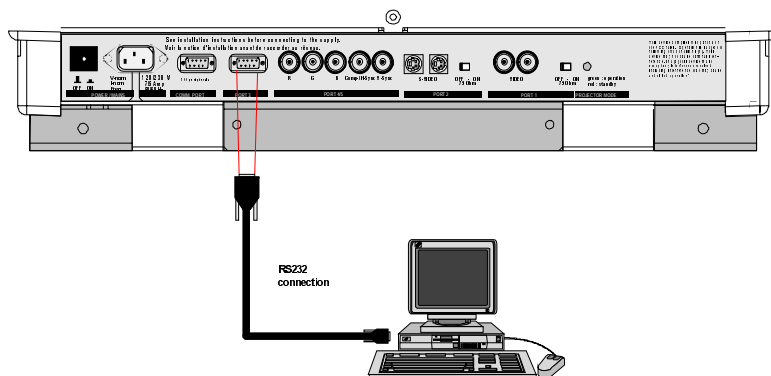

Communication port for communication with peripherals

Connecting a RCVDS 05 switcher to the projector.

- Up to 10 inputs (20 inputs when video and S-video) with the RCVDS 05 switcher and up to 90 inputs when 10 RCVDS switchers are linked via the expansion modules.
- Serial communication with the projector.
- Remote control buttons on the RCVDS to control the projector (source selection and analog settings)
- The selected source number will be displayed on a 2 digit display and the selected input modules will be indicated with a LED on the rear.

For more information about the use of the RCVDS 05, consult the Owner's Manual.

Connecting a VS05 switcher to the projector.

The VS05 can switch up to 5 Composite Video sources, 3 S-Video Sources and 1 RGB analog or component Video source to the projector. In addition, the audio signal proper to the source, can be switched to an audio amplifier.
Order number : R9827890.

For more information about the use of the VS05, consult the Owner's Manual.

Connecting an IR Remote Receiver to the projector.

This infrared receiver unit makes it possible to control the projector from another room. There is a communication line cable between the IR receiver and the projector or the RCVDS. The control information from the RCU can now be sent to the IR Remote Receiver. The IR Remote Receiver displays the selected source on a 7-segment display.

7

INSTALLATION ADJUSTMENT MODE

Installation Adjustments

How to enter the Service Menus ?

- 1 Press the **ADJUST** key.
The projector displays the 'Main menu' (menu 1).
- 2 Push the cursor keys **↑** or **↓** to select 'Service Menus'
- 3 Press **ENTER** to select.
A warning will be displayed (menu 2).
- 4 If qualified, press **ENTER** to continue
The Service menus main menu will be displayed (menu 3).

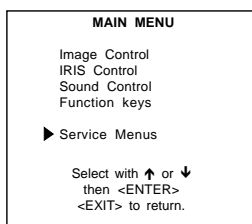

menu1

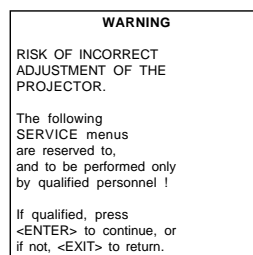

menu2

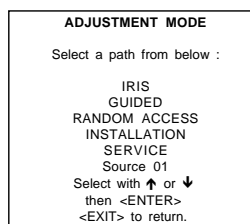

menu3

Installation Adjustment Mode Start Up

It will be necessary to perform several mechanical adjustments while in the Installation Adjustment Mode. It will be required to open and remove the projector's top cover in order to gain access to the adjustment points.

To enter into the installation adjustment mode :

- 1 Press the **ADJUST** to start up the adjustment mode.
- 2 Push the cursor keys **↑** or **↓** to highlight the path *INSTALLATION* in the "Adjustment mode" menu (menu 1).
- 3 Press the **ENTER** key.
A warning will be displayed on the screen (menu 2). If you are a qualified and authorized service person, press **ENTER** to start up the installation mode. Otherwise, press **EXIT** to return.
When entering the installation mode, the projector will automatically switch to the internal pattern on 15 kHz/50 Hz.
When the password mode is active, you will be requested to enter the 4 digit password.

Enter the digits with the numeric keys on the RCU or the local keypad.

Example : Password as 2 3 1 9

For each digit entered, a 'X' appears on the screen under the displayed text 'enter password'.

If the entered password is correct, you get access to the 'Installation Adjustment Mode'.

If the entered password is wrong, The message "*Wrong password!!!*" will be displayed. The projector stays on the previous selected item.

Factory programmed password :

0 0 0 0

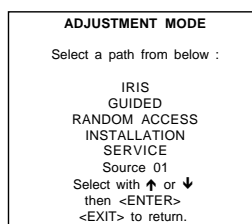

menu1

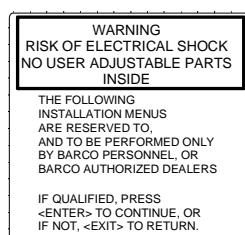

menu2

Overview flowchart of the Installation Adjustment Mode

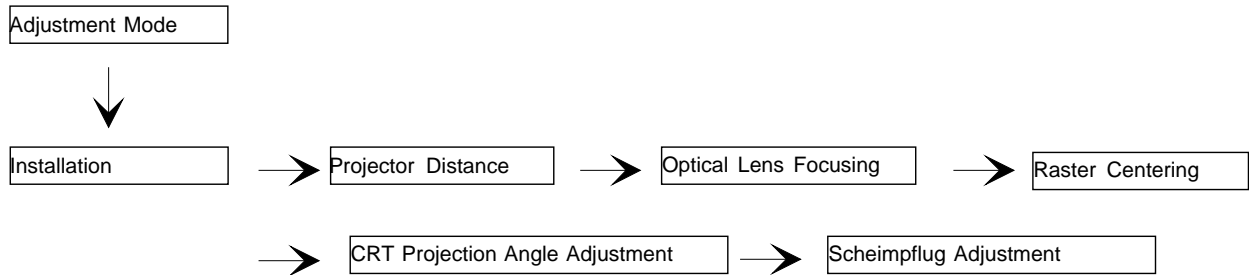

Important : Access to adjustments

The top cover of the projector should be removed in order to gain access to the adjustments. Please refer to chapter 'Installation Guidelines' for how to remove the top cover.

Projector Distance

What can be done ?

On the screen, a drawing will be displayed together with parameters indicating a correct installation position.

How to calculate the screen width ?

To change the screen width :

- 1 Push the cursor keys ← or → to highlight the item SW in the "Projector Distance 1" menu (menu 1)
- 2 Press **TEXT**.
After **TEXT** is pressed, the "Projector Distance 2" menu will be displayed on the screen (menu 2). It allows the user to change the Screen width.
- 3 Push the cursor keys ← or → to highlight the digit needed to be changed, and enter the desired digit with the numeric keys on the RCU or the local keypad.
- 4 Press **ENTER** to confirm the changes.
The projector will redisplay the "Projector Distance 1" menu with updated values for the three parameters.
- 5 Press **ENTER** to continue with the "Optical Lens Focusing".
If **EXIT** is pressed, the projector will return to the previous menu.

The same applies to the PD (projector distance). You can use the above-mentioned procedure to obtain a correct updated value of SW (screenwidth) after entering a new value of PD (projector distance).

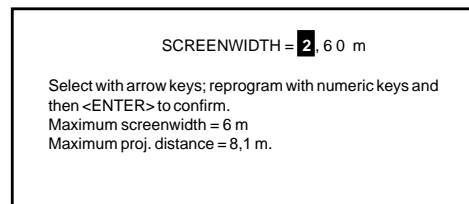
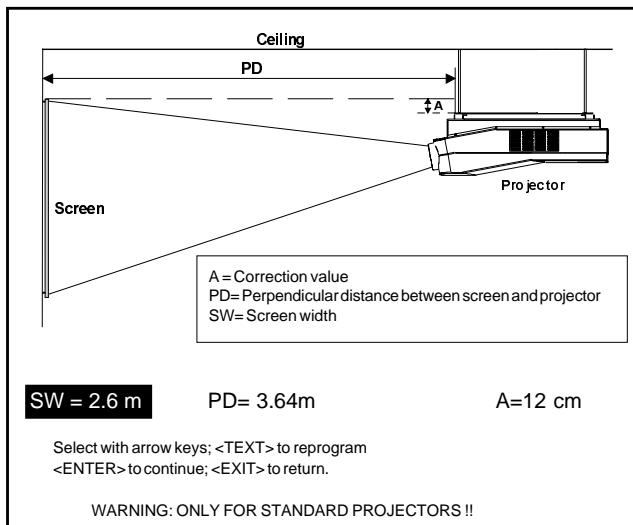

menu2

menu2

Optical Lens Focusing

What has to be done ?

The optical focusing procedure is performed separately for each lens. The appropriate CRT will be switched on as the user proceeds through the optical focusing adjustment sequence.

How to focus the lenses ?

Each lens has two focus adjustment points, one at the rear of the lens and one at the front. The center of the projected image is focused by loosening the wing nut at the rear end of the lens and rotating the lens barrel until the center of the image is clearly focused. The corners of the projected image are focused by loosening the wing nut at the front end of the lens and rotating the lens barrel until the corners of the image are clearly focused. Repetition of these adjustments may be necessary to optimize optical focusing.

Press **ENTER** to continue. After finishing focusing of the three lenses, press **ENTER** to enter the Raster centering.
 Press **EXIT** to return to operational mode.
 Press **ADJUST** to return to operational mode.

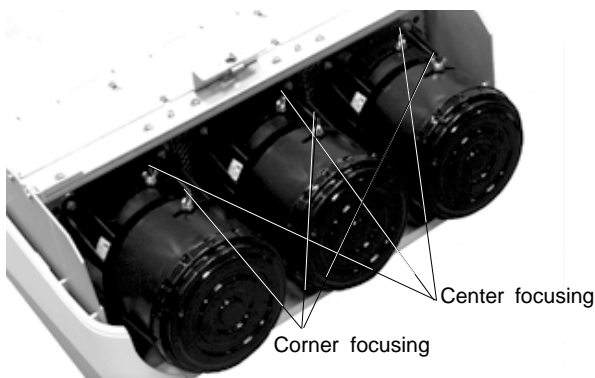

OPTICAL LENS FOCUSING
 1. LOOSEN THE NUT ON THE REAR OF THE GREEN LENS, ROTATE THE LENS BARREL TO FOCUS THE CENTER OF THE IMAGE. THEN TIGHTEN THE NUT
 2. LOOSEN THE NUT ON THE FRONT OF THE GREEN LENS AND ROTATE THE FRONT SECTION OF THE LENS TO FOCUS THE CORNERS OF THE IMAGE, THEN TIGHTEN THE NUT.
 <ENTER> to continue
 <EXIT> to return

menu 1

menu3

Raster Centering

What has to be done ?

The raster must be centered on the CRT faceplate of each tube, therefore, it is necessary to look into the lenses.

Caution : To avoid eye discomfort while performing these adjustments, reduce the contrast and gradually increase the brightness level until the raster becomes visible behind the image.

Warning

In order to ensure maximum CRT longevity and to avoid CRT damage, do not shift the raster outside the phosphor area of the CRT.

How to adjust ?

Press **ENTER** to display the raster on the green CRT.

Look into the green lens and shift the raster with the cursor keys until it is centered in the middle of the CRT faceplate.

RASTER CENTERING
 CONTRAST LEVEL IS REDUCED AND BRIGHTNESS INCREASED TO MAKE THE RASTER VISIBLE ON THE FACE PLATE OF EACH CRT.
 USE THE ARROW KEYS TO CENTER THE RASTER ON THE GREEN, RED AND BLUE CRT RESPECTIVELY
 <ENTER> to continue
 <EXIT> to return

menu 1

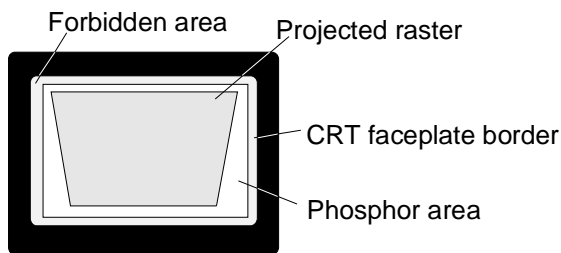

Image 1

Press **ENTER** to activate the raster on the Red CRT faceplate.
Shift the Red raster with the control stick until the raster is centered on the CRT faceplate.

Press **ENTER** to activate the raster on the Blue CRT faceplate.
Shift the Blue raster with the joy stick until the raster is centered on the CRT faceplate.

Press **ENTER** to continue with the CRT projection angle adjustment.

Press **EXIT** to return to Optical focusing.
Press **ADJUST** to return to Operational mode.

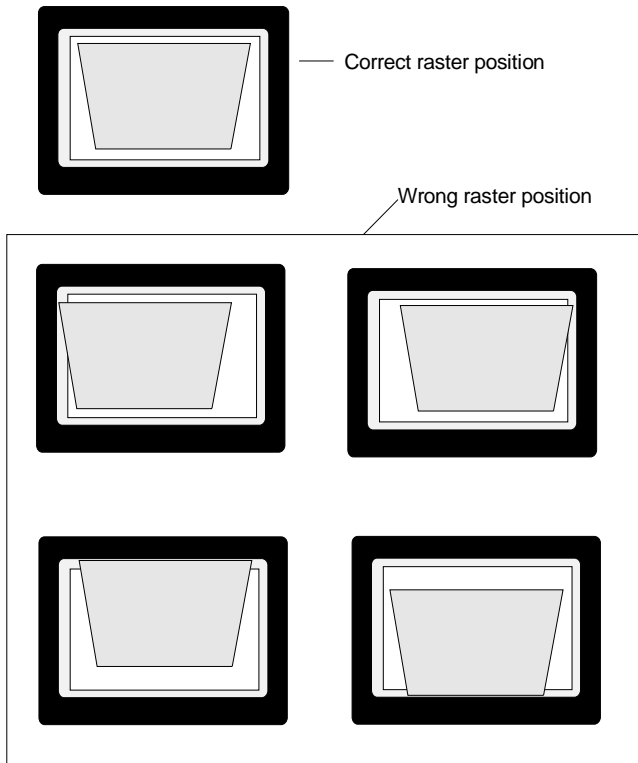

CRT Projection Angle Adjustment

What has to be done ?

The projection angle of the red and blue CRT's is dependent on the desired size of the projected image. If the centers of green, blue and red do not coincide, the CRT projection angle must be adjusted.

NOTE

Never try to correct this misalignment with the shift correction or the static convergence controls. These controls may only be applied to correct small errors which cannot be corrected by the CRT angle adjustment.
The Horizontal Shift and Vertical Shift for Red and Blue should be set near 50%.

Be sure that the rasters are centered on the CRT faceplate.

How to adjust ?

Press **ENTER** to start the CRT angle adjustment procedure.
Press **ENTER** to continue with the second part of the CRT projection angle adjustment.
Press **ENTER** to continue with the crosshairs alignment.
Press **EXIT** to return to the previous menu.
Press **ADJUST** to return to Operational mode.

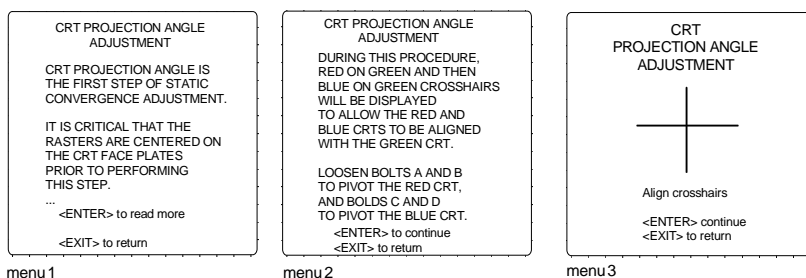

Loosen bolts A, B, C and D to pivot the red CRT until the center of the Red image and the center of the Green image coincide. When the angle of the red CRT is corrected, tighten the four bolts. Press **ENTER** to continue with blue and green crosshairs. Press **EXIT** to return to the CRT projection angle adjustment menu.

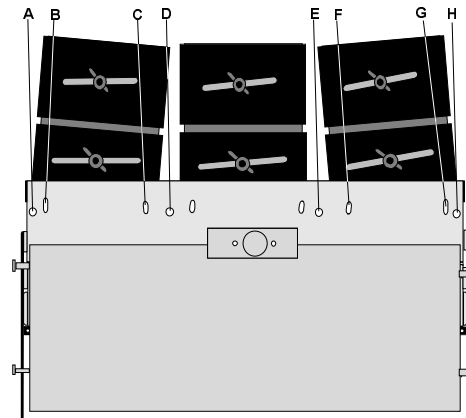
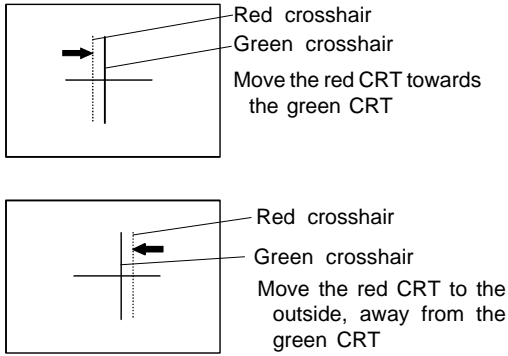

Loosen bolts E, F, G and H to pivot the blue CRT until the center of the Blue image and the center of the Green image coincide. When the angle of the blue CRT is corrected, tighten the four bolts. Press **ENTER** to continue with the diagonal focusing menu. Press **EXIT** to return to the CRT projection angle adjustment.

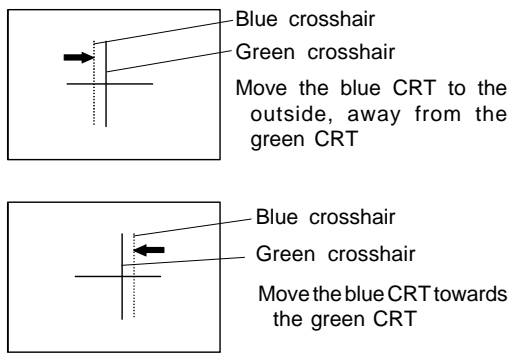

Projection angle correctly aligned for screen width SW1.

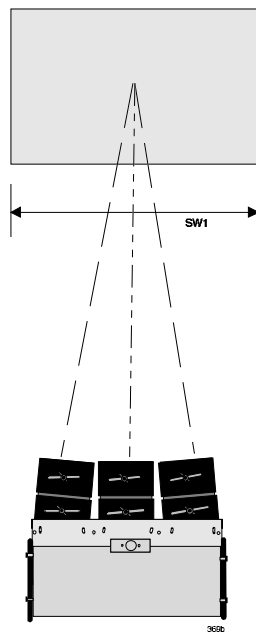

The same projection angle is misaligned for new screen width SW2. Realignment is necessary. Each screen width change requires readjustment of the projection angle.

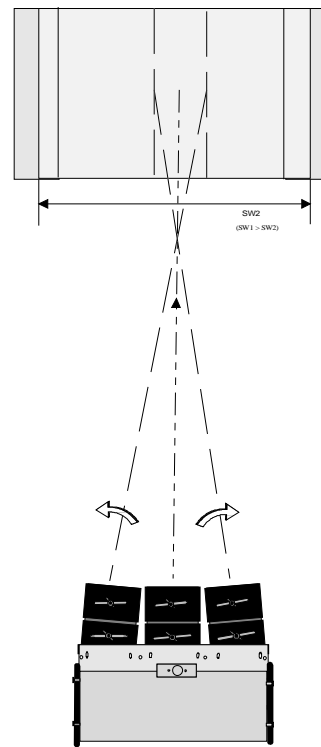

Scheimpflug Adjustment (Diagonal image focusing)

What can be done ?

With the diagonal image focusing corrections, it is possible to obtain uniform focus for the total projected image.

These corrections must be repeated for each color. The Diagonal image focusing is repeated 3 times, first for green, then for red and then for blue.

How to adjust ?

First, be sure that the CRT projection angle is correctly adjusted, otherwise it is not possible to obtain proper overall focus of the image.

- 1 Press **ENTER** to start the green adjustment.
- 2 Press **EXIT** to return to CRT Projection Angle Adjustment.
- 3 Press **ADJUST** to return to Operational mode.

Adjustment procedure :

Example : diagonal focusing of the green image.

Equalize diagonally the focus from left (bottom) to right (top) by turning screw 01 of the projected color.

Equalize now diagonally the focus from left (top) to right (bottom) by turning screw 00 located under the green lens.

Repeat the same procedure for the red and blue image using the corresponding screws.
To optimize the image focusing, repeat the optical lens focusing.

DIAGONAL IMAGE FOCUSING

1. TURN THE SCREW MARKED 01 TO FOCUS THE IMAGE DIAGONALLY from LEFT (bottom) TO RIGHT (top).
2. TURN THE SCREW MARKED 00 TO FOCUS THE IMAGE DIAGONALLY from LEFT (top) TO RIGHT (bottom)

<ENTER> to continue
<EXIT> to return

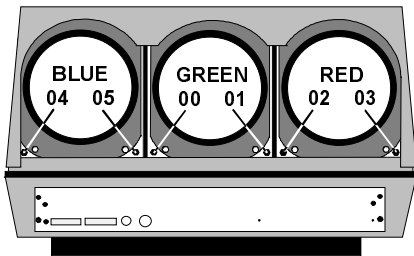

	Left	Right
GREEN	00	01
RED	02	03
BLUE	04	05

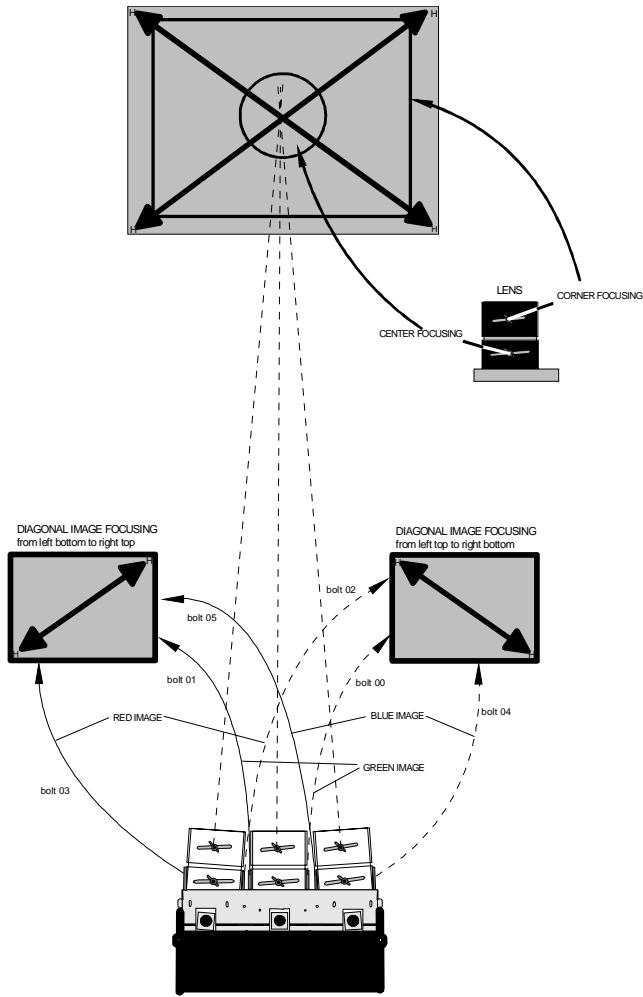

e.g. : Turning bolt 03 will influence the diagonal focus for Red from left bottom to right top

Finishing the installation mode.

After finishing the Installation Adjustment Procedures, the main menu returns on the screen. You are now able to start the alignment procedure for the projector. You have the choice between:

- Guided adjustment procedure;
- Random Access Adjustment procedure.

Press **ENTER** to continue with the chosen path.

Press **EXIT** to return to Operational mode.

Press **ADJUST** to return to Operational mode.

For detailed information about these adjustments, please refer to the Owner's Manual.

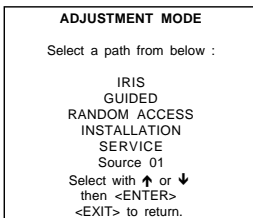

menu 1

A

G2 ADJUSTMENT

G2 Adjustment

How to start up the G2 adjustment ?

- 1 Enter the adjustment mode by pressing **ADJUST** (menu 1).
- 2 Highlight **SERVICE**.
- 3 Press **ENTER** to start up the service mode (menu 2).
- 4 Highlight G2 Adjustment
- 5 Press **ENTER**.

A safety notice will be displayed to warn the operator (menu 3).

If you are qualified, press **ENTER** to continue with the G2 adjustment, otherwise press **EXIT** to return to the service menu.

If **ENTER** is pressed, the G2 menu will be displayed (menu 4).

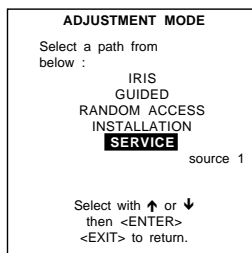

menu 1

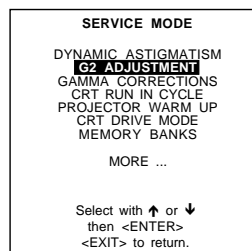

menu 2

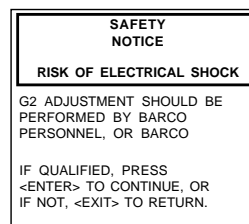

menu 3

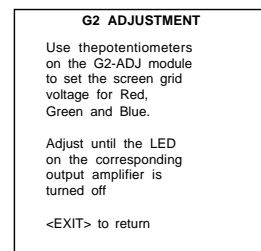

menu 4

How to adjust the G2 ?

- 1 Remove the top cover from the projector (see Installation Guidelines).
- 2 Open the front metal protection cover by turning out the 3 retaining screws on both sides (Photo 1). A green LED is mounted on each of CRT sockets (see Photo 2).



Photo 1

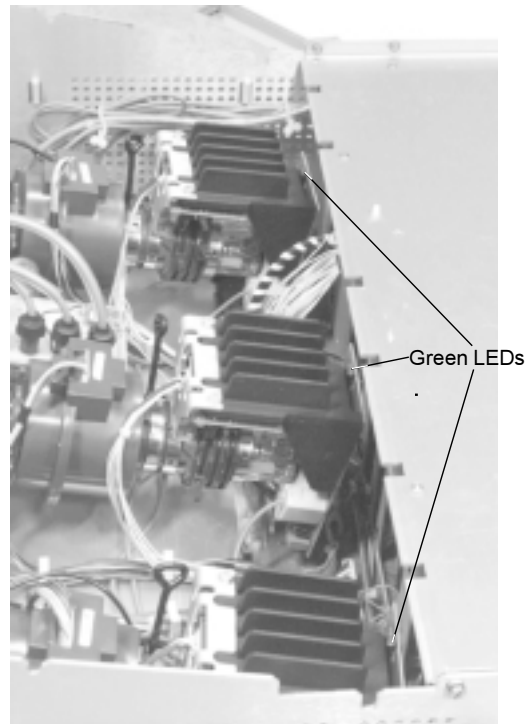

Photo 2

Appendix A: G2 adjustment

When selecting the G2 adjustment menu, these green LEDs must be out. If not, follow the procedure below to adjust the G2:

- 1 Open the second metal cover by turning out the retaining screws on both sides and pivot the cover to the front side of the projector
- 2 Adjust the G2 potentiometers (see Photo 3) very slowly with a plastic tweaker until the LED of the corresponding amplifier just stops illuminating. Repeat the adjustment for the other colors;
- 3 After the three G2 potentiometers have been correctly adjusted, close both metal covers and secure with the retaining screws.

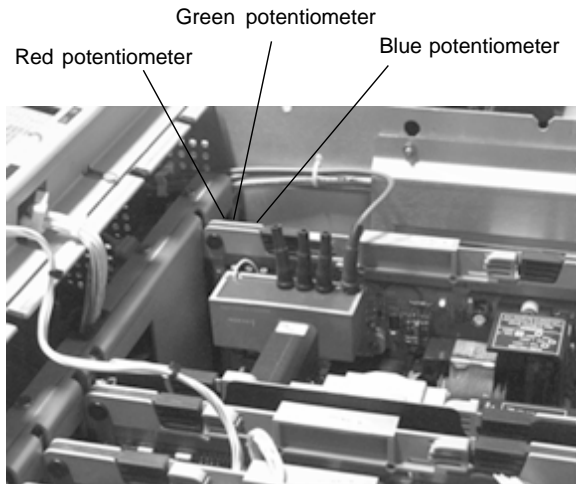

Photo 3

After finishing the adjustments :

Press **ENTER** to continue with the "SERVICE" menu.

Press **EXIT** to return to the "SERVICE" menu.

Press **ADJUST** to return to Operational mode.

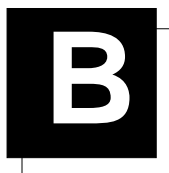

GAMMA CORRECTIONS

Gamma Corrections

Warning Entering Gamma corrections

"RISK OF INCORRECT ADJUSTMENT OF THE PROJECTOR.
THE GAMMA CORRECTIONS ARE FACTORY ADJUSTED USING AN ACTAS COLOR ANALYZER ! THEREFORE, ONLY QUALIFIED INSTALLATION OR SERVICE PERSONNEL SHOULD PERFORM THESE ADJUSTMENTS ! "

If you are qualified, press **ENTER** to continue.

WARNING RISK OF INCORRECT ADJUSTMENT OF THE PROJECTOR.
THE GAMMA CORRECTIONS ARE FACTORY ADJUSTED USING AN ACTAS COLOR ANALYZER ! THEREFORE, ONLY QUALIFIED INSTALLATION OR SERVICE PERSONNEL SHOULD PERFORM THESE ADJUSTMENTS ! <ENTER> TO CONTINUE <EXIT> TO RETURN.

How to adjust ?

Three items can be selected inside the "Gamma Corrections" menu: the Blue Gamma Correction, the R & B midlights and the factory preset.

Blue Gamma Correction

- 1 Push the cursor keys **↑** or **↓** to highlight the item *BLUE GAMMA CORRECTION* in the menu (menu 1).
- 2 Press **ENTER**.
If **EXIT** is pressed, the projector will return to the *Service* menu.
After **ENTER** is pressed, a text box with the message, "Adjust with arrow key", will be displayed on the screen.
- 3 Push the cursor keys **↑** or **↓** to adjust the slope, a text box with a bar scale (Min to Max) will be displayed to visualize the magnitude of the correction (menu 2).
- 4 Push the cursor keys **→** or **←** to adjust the breakpoint, a text box with a numeric bar scale (0-99) will be displayed to visualize the magnitude of the correction (menu 3).
- 5 Press **ENTER** to return to the "Gamma Corrections" menu.

GAMMA CORRECTIONS BLUE GAMMA CORRECTION Adjust slope with ↑ or ↓ Breakpoint with ← or → R & B MIDLIGHTS Adjust red with ↑ or ↓ blue with ← or → FACTORY PRESET Select with ↑ or ↓ then <ENTER>; <EXIT> to return.
--

menu 1

BLUE GAMMA SLOPE

menu 2

BLUE GAMMA BREAKPOINT

menu 3

Red and Blue Midlights Correction

- 1 Push the cursor keys **↑** or **↓** to highlight the item *R & B MIDLIGHTS* in the menu (menu 1).
- 2 Press **ENTER**.
If **EXIT** is pressed, the projector will return to the *Service* menu.
After **ENTER** is pressed, a text box with the message "Adjust with arrow key", will be displayed on the screen.
- 3 Push the cursor keys **↑** or **↓** to adjust the Red Midlights, a text box with a bar scale (0-16) will be displayed to visualize the magnitude of the correction (menu 2).
- 4 Push the cursor keys **→** or **←** to adjust the Blue Midlights, a text box with a bar scale (0-16) will be displayed to visualize the magnitude of the correction (menu 3).
- 5 Press **ENTER** to return to the "Gamma Corrections" menu.

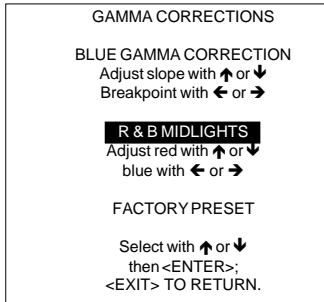

menu 1

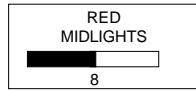

menu 2

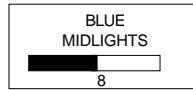

menu 3

Back to the factory preset values

- 1 Push the cursor keys **↑** or **↓** to highlight the item *FACTORY PRESET* in the menu (menu 1)
- 2 Press **ENTER**.
- 3 Press **EXIT** to return to the *Service* menu.

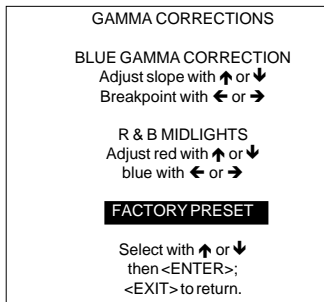

menu 1

MATERIAL SAFETY DATA SHEET				Form Approved Bureau Budget No. 45-R0338			
SECTION I	MANUFACTURER'S NAME AND FSCM (<i>Federal Supply Code for Manufacturer's</i>) <i>BARCON.V.</i>			EMERGENCY PHONE NO. <i>32-56-368211</i>			
	ADDRESS (<i>Number, Street, City, State, and ZIP Code</i>) <i>Noordlaan 5 B-8520 KUURNE</i>						
	CHEMICAL NAME AND SYNONYMS <i>Ethylenglycol & Glycerol</i>			TRADE NAME AND SYNONYMS <i>Cooling liquid 512334</i>			
	CHEMICAL FAMILY <i>Polyalcohols</i>		FORMULA <i>C₂H₆O₂+C₃H₈O₃</i>				
	FEDERAL STOCK NUMBER (<i>FSN</i>)		GROSS WEIGHT (<i>LBS</i>)	OUTSIDE PACKAGE DIMENSIONS (<i>Inches</i>)			
	MIL-STD-1341/NATIONAL FIRE PROTECTION ASSOCIATION STD 704M SIGNAL						
FLAMMABILITY.....		HEALTH.....	REACTIVITY.....	SPECIFIC HAZARD.....			
SECTION II - HAZARDOUS INGREDIENTS	PAINTS, PRESERVATIVES, AND SOLVENTS	%	TRESHOLD LIMIT VALUE (<i>Units</i>)	ALLOYS AND METALLIC COATINGS	%	TRESHOLD LIMIT VALUE (<i>Units</i>)	
	PIGMENTS	/		BASE METAL	/		
	CATALYST	/		ALLOYS	/		
	VEHICLE	/		METALLIC COATINGS	/		
	SOLVENTS	/		FILLER METAL PLUS COATING OR CORE FLUX	/		
	ADDITIVES	/		OTHERS	/		
	OTHERS	/					
	HAZARDOUS MIXTURES OF OTHER LIQUIDS, SOLIDS, OR GASES					%	TRESHOLD LIMIT VALUE (<i>Units</i>)
SECTION III PHYSICAL DATA	BOILING POINTS (<i>°C.</i>)	<i>201°C</i>		SPECIFIC GRAVITY (<i>H₂O=1</i>)	<i>1.15</i>		
	VAPOR PRESSURE (<i>mm Hg.</i>)	<i>3 mm Hg</i>		PERCENT VOLATILE BY VOLUME (%)	/		
	VAPOR DENSITY (<i>AIR=1</i>)	<i>2.2</i>		EVAPORATION RATE (<i>.....=1</i>)	/		
	SOLUBILITY IN WATER	∞					
	APPEARANCE AND ODOR						
SECTION IV - FIRE AND EXPLOSION HAZARD DATA	FLASH POINT (<i>Method used</i>)	FLAMMABLE LIMITS	LOWER EXPLOSIVE LIMIT	UPPER EXPLOSIVE LIMIT			
	EXTINGUISHING MEDIA						
	SPECIAL FIRE FIGHTING PROCEDURES						
	UNUSUAL FIRE AND EXPLOSION HAZARDS						

SECTION V HEALTH HAZARD DATA	TRESHOLD LIMIT VALUE <i>100ppm</i>		
	EFFECTS OF OVEREXPOSURE		
	EMERGENCY AND FIRST AID PROCEDURES		
SECTION VI REACTIVITY DATA	STABILITY	UNSTABLE	CONDITIONS TO AVOID
		STABLE	X
	INCOMPATABILITY <i>(Materials to avoid)</i>		
	HAZARDOUS DECOMPOSITION PRODUCTS		
	HAZARDOUS POLYMERIZATION	MAY OCCUR	X
	WILL NOT OCCUR		
SECTION VII SPILL OR LEAK PROCEDURES	STEPS TO BE TAKEN IN CASE MATERIAL IS RELEASED OR SPILLED		
	<i>Rinse with water</i>		
	WASTE DISPOSAL METHOD		
SECTION VIII - SPECIAL PROTECTION INFORMATION	RESPIRATORY PROTECTION <i>(Specific type)</i>		
	VENTILATION	LOCAL EXHAUST	SPECIAL
		MECHANICAL <i>(General)</i>	OTHER
	PROTECTIVE GLOVES	EYE PROTECTION	
	OTHER PROTECTIVE EQUIPMENT		
SECTION IX SPECIAL PRECAUTIONS	PRECAUTIONS TO BE TAKEN IN HANDLING AND STORING		
	<i>Harmful if swallowed</i>		
	<i>Keep out of the reach of children</i>		
	OTHER PRECAUTIONS		
	<i>To avoid from oxidants</i>		

THE INFORMATION CONTAINED HEREIN IS BASED ON DATA CONSIDERED ACCURATE. HOWEVER, NO WARRANTY IS EXPRESSED OR IMPLIED REGARDING THE ACCURACY OF THESE DATA OR THE RESULTS TO BE OBTAINED FROM THE USE THEREOF. VENDOR ASSUMES NO RESPONSABILITY FOR INJURY TO VENDEE OR THIRD PERSONS PROXIMATELY CAUSED BY THE MATERIAL IF REASONABLE SAFETY PROCEDURES ARE NOT ADHERED TO AS STIPULATED IN THE DATA SHEET. ADDITIONALLY, VENDOR ASSUMES NO RESPONSABILITY FOR INJURY TO VENDEE OR THIRD PERSONS PROXIMATELY CAUSED BY ABNORMAL USE OF THE MATERIAL EVEN REASONABLE SAFETY PROCEDURES ARE FOLLOWED. FUTHERMORE, VENDEE ASSUMES THE RISK IN HIS USE OF THE MATERIAL.