

BARCO

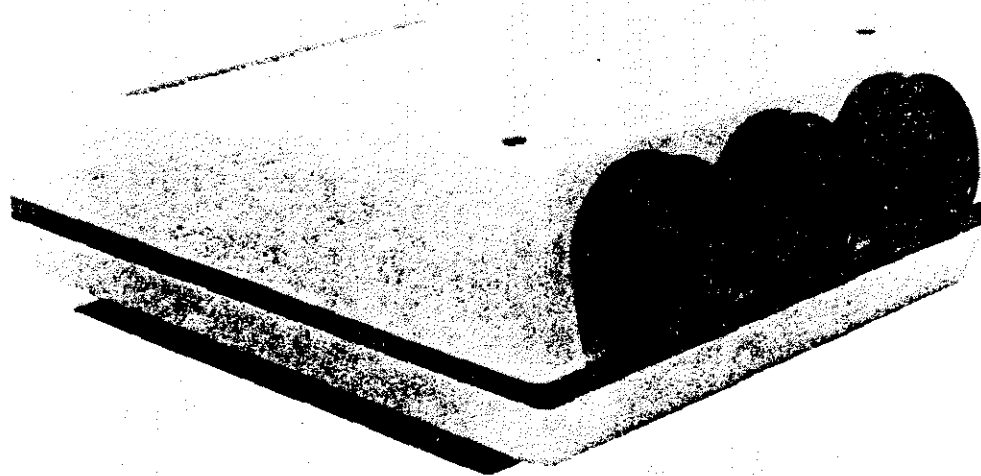

BARCO DATA

90 00050

INTRODUCTION

The BARCO projector is designed for composite video in all existing broadcast standards, RGB(S) analogue signals and RGB-HVS-TTL signals as well as many non-standard frequencies. It will display the signals in colour from all standard video tape recorders and video disk outputs in both North American and European standards. However, it is primarily designed for data display, both alphanumeric and graphics. As such it must operate at many non-standard line rates and frame rates.

CONTENTS

INTRODUCTION

PERFORMANCE DATA AND SPECIFICATIONS

Page

I. OPERATION AND SERVICE CONTROLS	1 - 2
II. VIDEO CIRCUITS	2
III. RGB(S) ANALOG CIRCUIT	2 - 3
IV. RGB-HVS-TTL CIRCUIT	3
V. DEFLECTION CIRCUITS	3
VI. HIGH VOLTAGE	3
VII. POWER REQUIREMENTS	4
VIII. DISPLAY	4
IX. MECHANICAL CHARACTERISTICS	4
X. MOUNTING	4
XI. VIDEO COLOUR STANDARDS	5
XII. SAFETY	5
XIII. ENVIRONMENT	5

POSITION OF THE PROJECTOR

6

INSTALLATION + CABINET DIMENSIONS

7 - 7a

ADAPTATION TO CEILING FRONT OR FLOOR FRONT OPERATION
 REAR REAR

8

TOP COVER REMOVAL

9

POWER INPUT BOARD

10

ADAPTATION POWER INPUT : 110V AC OR 220V AC

	<u>Page</u>
ELECTRICAL CONNECTIONS	
A. POWER	11
B. CONTROLS	11 - 12
C. SIGNAL PROCESSING	
1. Input signal : VIDEO COMPOSITE	13 - 14
2. Input signal : RGB Analog or RGB TTL	
2a. RGB Analog input	15 - 17
2b. RGB TTL input	18 - 21
 OPERATION	 22 - 24
 SERVICE ADJUSTMENTS AND ALIGNMENTS	
A. PICTURE CENTERING	25
1. ON CRT SCREEN	26
2. ON PROJECTION SCREEN	27 - 28
 B. PICTURE GEOMETRY ADJUSTMENTS	
a) Common adjustments	
1. VERTICAL LINEARITY and AMPLITUDE	29
2. HORIZONTAL LINEARITY and AMPLITUDE	30
3. Hor. correction : BOW - TRAP. DISTORSION - PCC	31
b) Adjustment for each colour picture	
1. HORIZONTAL PICTURE WIDTH	31
2. Vert. corrections : TRAP. DISTORSION - BOW - NORTH/SOUTH AMPLITUDE	32
 C. PICTURE SHARPNESS ADJUSTMENT	
1. Lens focus adjustment	33
a) Mechanical focussing in the MIDDLE of the screen	34
b) Mechanical focussing in the CORNERS of the screen	34
2. Electrical focussing	34

D. CONVERGENCE ADJUSTMENT

I. Static convergence (center screen) 35

II. Dynamic convergence

1. Vertical and horizontal convergence of the Red and Green picture 36

2. Vertical and horizontal convergence of the Blue and Green picture 37

3. Additional convergence for the vertical lines of Red and Blue on the left and right outside of the picture 37 - 38

4. Additional convergence for Red and Blue when operating on high line frequency

a) Hor. static control for Blue and Red 38

b) Hor. dynamic control for Red/Blue at the most left and right side of the picture 38 - 39

E. CUT-OFF ADJUSTMENT (GREY SCALE BALANCE) 39 - 40

F. HOR. PHASE ADJUSTMENT : POT. P7 40

I. OPERATION AND SERVICE CONTROLS

FRONT : optical focussing of projection lens (independent center and edge focus adjustment)

REAR EXTERNAL : - Power ON/OFF switch

- On control box, plugged in on the projector or via remote cable (connector, D-type 15 pins)

Brightness control

Contrast control

Tint control

Colour saturation control

Decoder selection P S N4 / P S N3

Sync selection Slow/Fast

Input mode selection Video/RGsb/RGbs/RGB TTL

Two line/frame frequency selection Fstd/Fadj

Frequency adjustment : Line & Frame in Fadj mode

- AC power input

INTERNAL (top cover opened) :

- electrical focussing Red, Blue and Green

- on Sync + Vert. deflection board

Adjustment of : Horizontal Hold I

Vertical Hold I

Hold I : - 50 Hz

- 60 Hz + adj. 50/60 Hz
detector

Horizontal Phase

Vertical Blanking (650 → 1600 us)

50/60 Hz detector

Picture geometry : Vertical linearity and amplitude

Vertical amplitude 60 Hz

Vertical shift for Red, Green and Blue

Horizontal amplitude I and II

Horizontal trapezium

Horizontal bow

Horizontal Pin Cushion Correction

- on N/S + Hor. Shift board

Picture adjustments : Horizontal shift for Red, Green and Blue

N/S amplitude for Red, Green and Blue

Vertical Bow for Red, Green and Blue

Trap-distorsion for Red, Green and Blue

Picture width for Red, Green and Blue

- on RGB-TTL board

Adjustment of : - Blue in Green

- Hor. sync delay

- High/low intensity

Switches : - Input TTL signals from neg. to pos. logic

(Blue, Green, Red, Hor. sync,
Vert. sync, Composite sync)

- High/low intensity inversion

- Hor. sync delay ON/OFF

- Blue in Green ON/OFF

- on RGB analog board

Adjustment of : - Level Blue in Green

Switches : - Blue in Green OFF

- Sync input 1V or 4V (for separate sync input signal)

- 75 Ohm termination ON/OFF for Red, Green, Blue and separate sync signal

II. VIDEO CIRCUITS

INPUT : 2 BNC connectors (looped through)

75 Ohm termination switch

1 Vpp + 6 dB

III. RGB(S) ANALOG CIRCUIT

Input selector : switch RGB analog/RGB-TTL → RGSB : for sync on Green
or
→ RGB+S : for separate sync

INPUT : 4 BNC connectors :

Red 0,7 Vpp \pm 3 dB

Green 0,7 Vpp \pm 3 dB

1 Vpp \pm 3 dB if sync on green

Blue 0,7 Vpp \pm 3 dB

Sync (separate) 4 Vpp neg. \pm 3 dB or 1 Vpp (switchable)

(All inputs are 75 Ohm terminated by means of a switch on the RGB analog board).

IV. RGB-HVS-TTL CIRCUIT

Input selector : switch RGB analog/RGB-TTL \rightarrow RGB-TTL

Input : - D-type 9 pin connector

- standard TTL levels for Red, Green, Blue, Comp. sync or Hor. & Vert. sync or Hor. & Vert. Blanking, High-Low info

- all inputs TTL switchable from pos. to neg. logic

(switches on RGB-TTL board)

V. DEFLECTION CIRCUITS

VERTICAL DEFLECTION

Frequency range : from 50 Hz to 110 Hz

Retrace time : 650 us

HORIZONTAL DEFLECTION

Frequency range : Fstd : line 15625 Hz - Frame 50 Hz
line 15750 Hz - Frame 60 Hz

Fadj : line 15625 Hz upto 32 kHz - Frame 50 Hz upto
110 Hz

Retrace time : < 7 us

Note : scanning rates can be adjusted on 2 different values (I and II) for video or RGB inputs. (Max. 10 different values when using the source selector RCVDS 2).

VI. HIGH VOLTAGE

Stabilised EHT : 34.7 KV

VII. POWER REQUIREMENTS

- 220V AC + 10 % - 15 % can be internally switched for 110V AC + 10 % - 15 %
- frequency independence between 40 - 100 Hz
- rated consumption : 350 W

VIII. DISPLAY

- Projection tubes : - 5" high resolution rectangular projection tubes
- liquid cooled system
 - colours : Red, Green and Blue
- Lenses : high resolution F 1.0 lenses, with independent center and edge focus adjustment.
- Picture format : 3 x 4 ratio.
- Picture dimensions (standard version) : min 1 m x 0.75 m
max 2.6 m x 1.95 m
- Throw distance : 1.6 x picture width (see table)
- Max light output : 440 lumens (measured on 20 % peak white)
- Screen application : flat, parabolic or cylindrical screen
- Geometric distorsion : ± 1 % in circle equal to picture height
 ± 1.5 % outside
- Convergence : calibration using 9 independent zones

IX. MECHANICAL CHARACTERISTICS

- Dimensions : 830 mm (L) x 565 mm (W) x 235 mm (H)
- Weight : 37 kg

X. MOUNTING

Table mounting and ceiling mounting; front projection and rear projection possibility in both mounting positions.

Adaptation ceiling ↔ table : incorporated switch

Adaptation front ↔ rear : incorporated switch

XI. VIDEO COLOUR STANDARDS

PAL - SECAM - NTSC 4.43 - NTSC 3.58 :

- automatic selection between PAL - SECAM and NTSC
- switchable between PAL/SECAM/NTSC 4.43 and PAL/SECAM/NTSC 3.58 by external switch on the CONTROL SWITCH BOX.

XII. SAFETY

The unit meets all relevant international standards.

X-radiation : DHHS

Safety : IEC 65

Interference suppression : FCC

XIII. ENVIRONMENT

Max. operating range

Temperature : 0° to 40° C

Humidity : 0 - 90 % non condensing

Altitude : 0 - 3,000 m (0 - 10,000 ft)

Storage

Temperature : - 30° to 65° C

POSITION OF THE PROJECTOR

The following graphic indicates the projector distance (screen-top U bracket) in function of the wanted screen width for all projector applications (ceiling or desk).

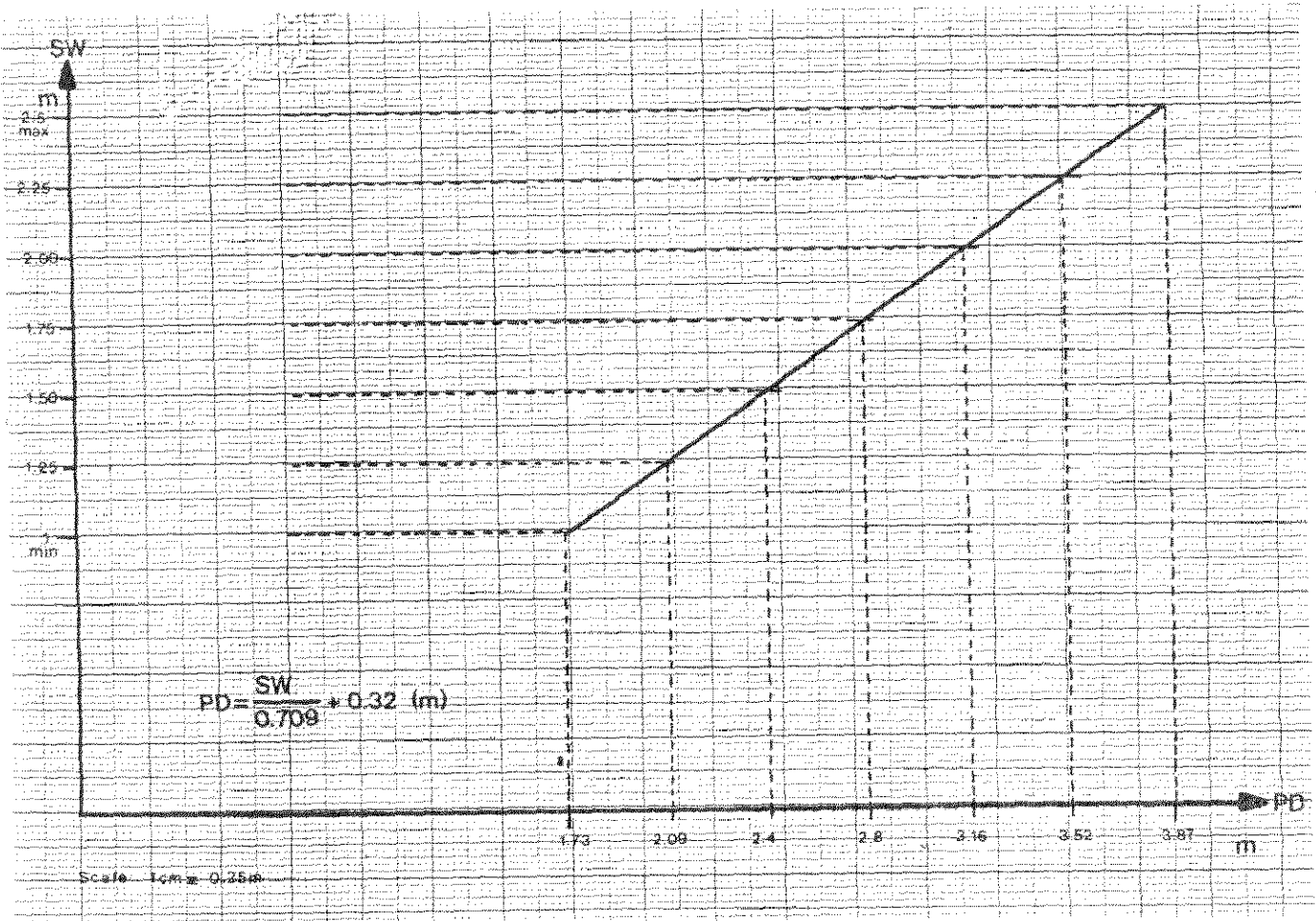
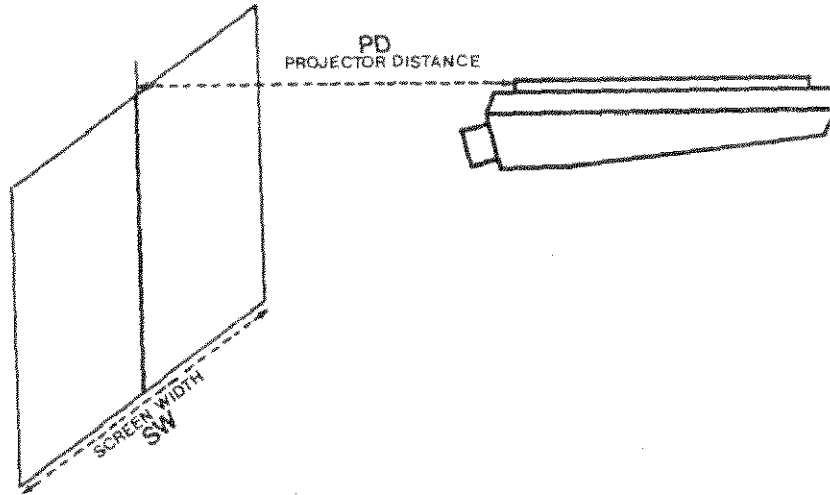

INSTALLATION

WARNING

- In order to avoid any convergence faults, be sure first that the projector is always installed level (therefore use a water-level) and secondly that the projector axis is perpendicular on the screen surface (see fig.).

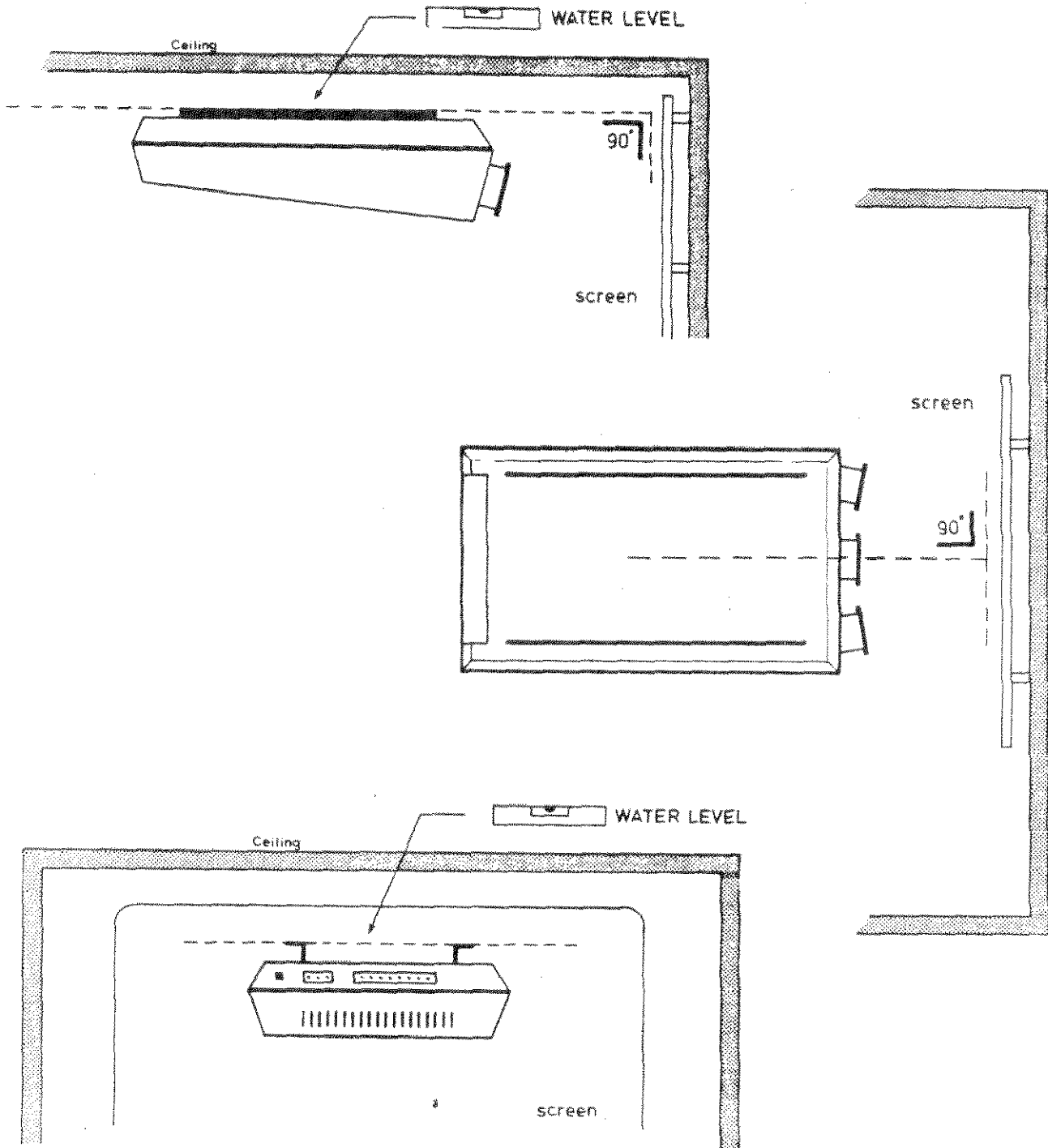

PROJECTOR CABINET DIMENSIONS

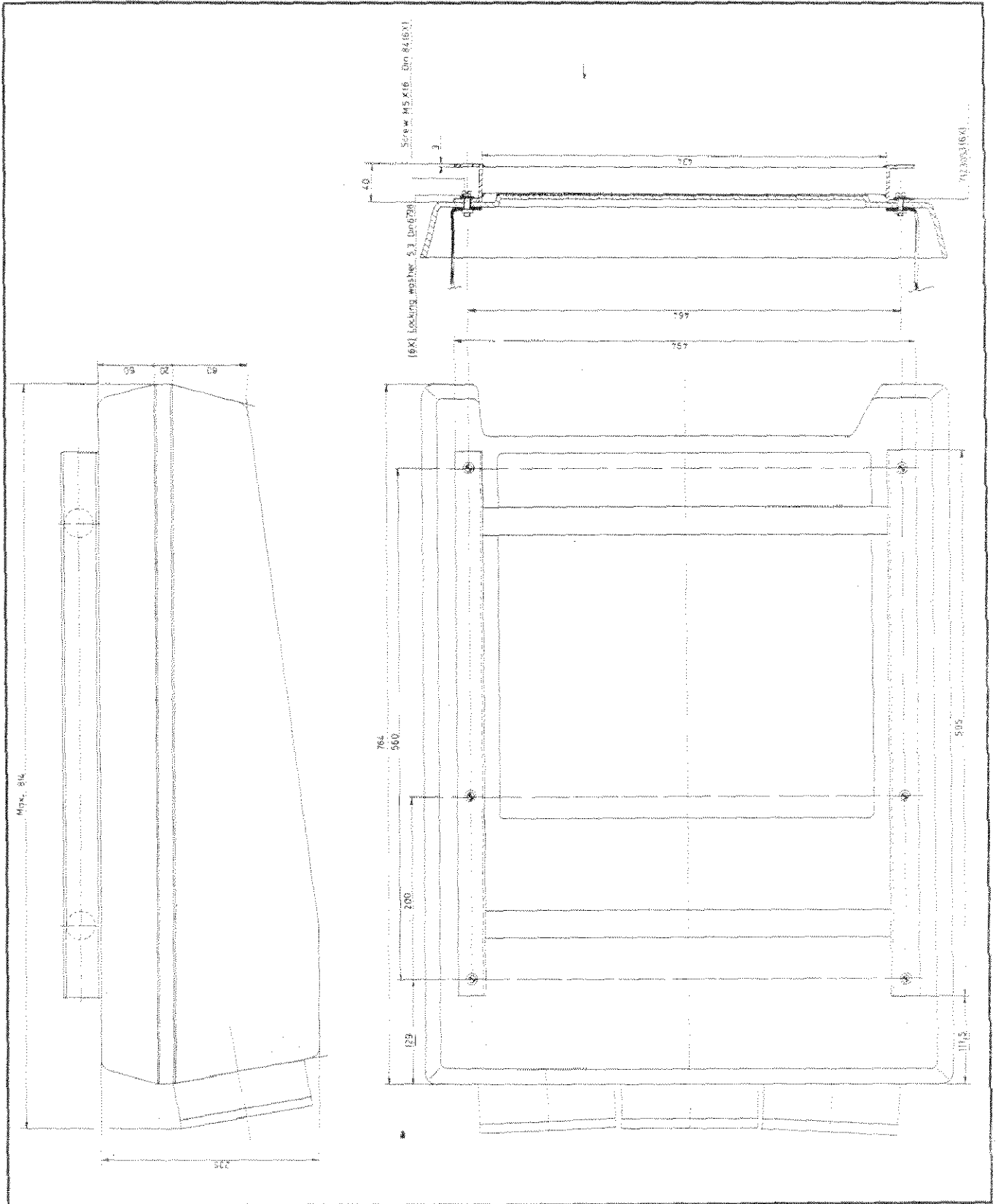





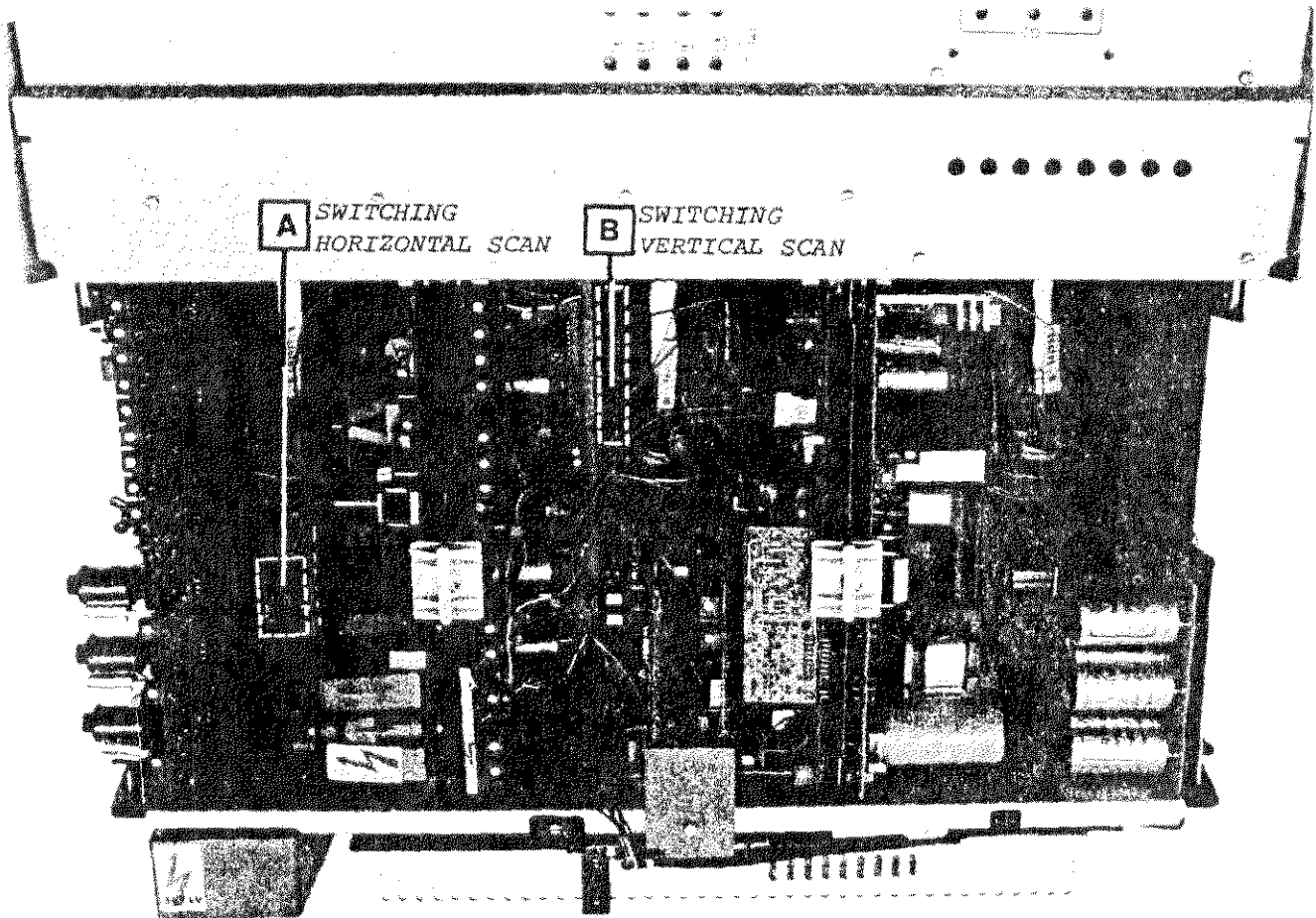





The BARCODATA has reversal capability for ceiling, floor and rear-screen applications. Therefore, two switches are provided on the motherboard of the projector.

IMPORTANT : Scan reversion has to be done always with the projector switched off.



Positions of the switches :

Switch	Ceiling Front	Ceiling Rear	Floor Front	Floor Rear
A				
B				

 pressed
 not pressed

Note : Switching over from floor to ceiling or reversed requires a complete readjustment of picture geometry and convergence (see "Service adjustment and alignments of the BARCODATA").

TOP COVER REMOVAL

Unlock the top cover by turning both fixation screws anti-clockwise a quarter of a turn.

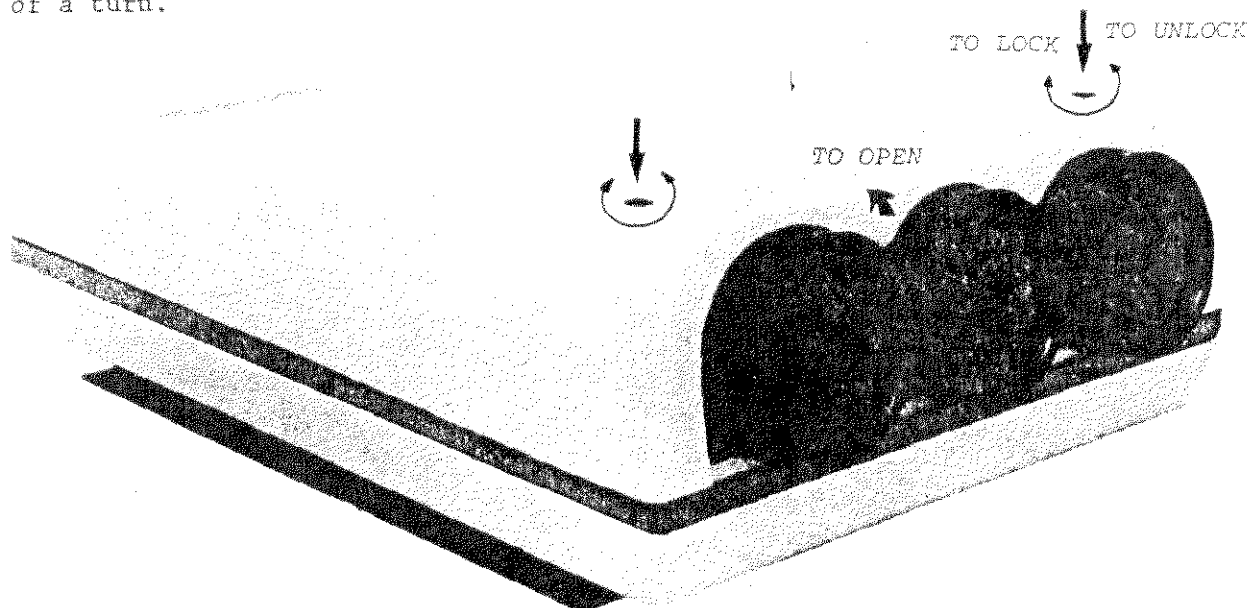

Open the top cover by lifting it up. An incorporated support keeps the top cover opened.

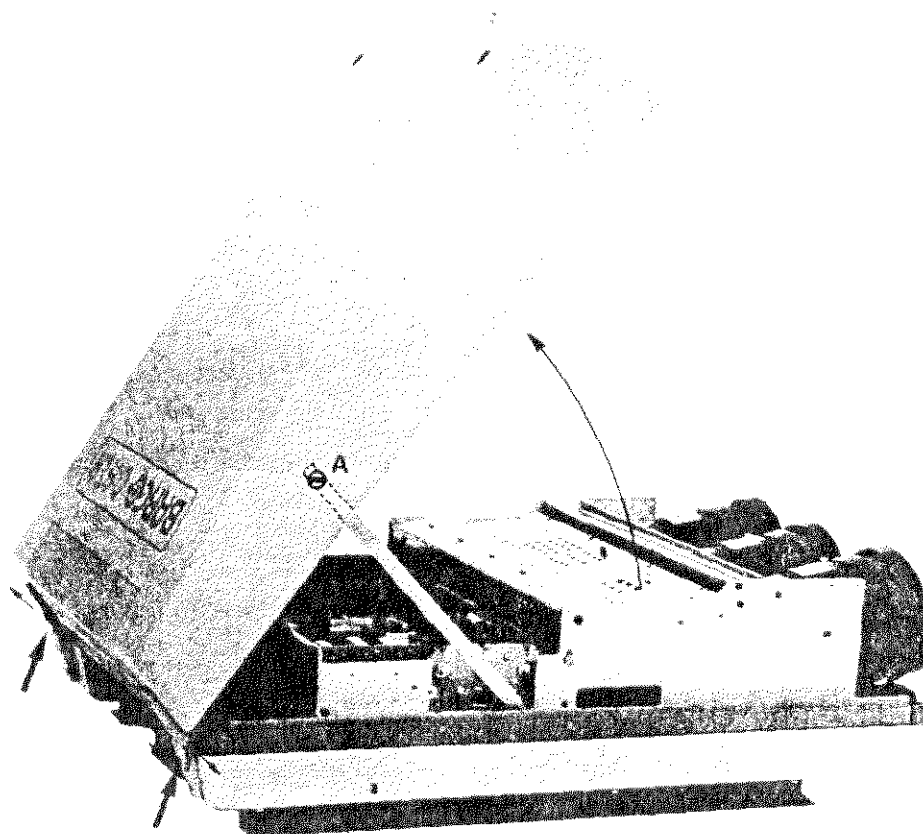

Note : The top cover can be removed when removing screw A and the two hinge-joints of the hinges.

BARCODATA - BOARD LOCATIONS

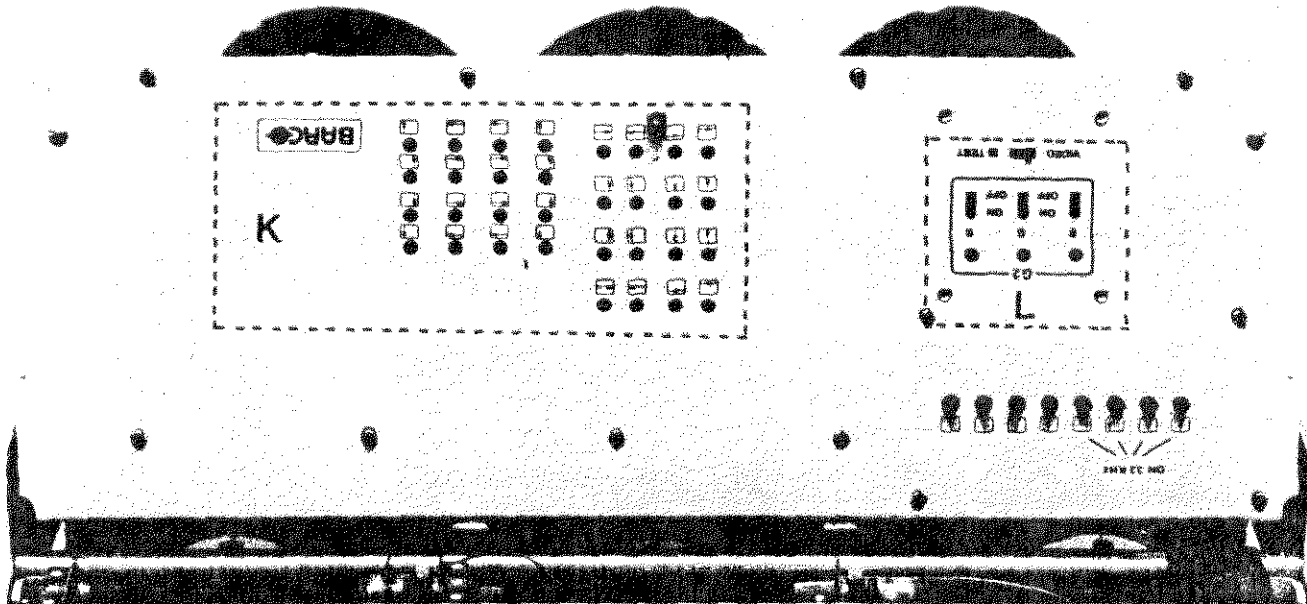

(A) RGB TTL INPUT	76 11155	(G) FOCUS CONTROL + CONTROL LAMPS	76 1198
(B) RGB ANALOG INPUT	76 11145	(H) POWER INPUT	76 11802
(C) VIDEO INPUT + CONVERGENCE GENERATOR	76 12135	(I) P.S. N3 N4 DECODER + RGB OUTPUT	76 11605
(D) SWITCH MODE POWER SUPPLY	76 1175	(J) NORTH-SOUTH CORRECTION	76 1254
(E) SYNC + VERT. DEFLECTION	76 1271	(K) CONVERGENCE	76 1282
(F) HOR. DEFLECTION + EHT	76 1262	(L) G2-CONTROL	76 11995

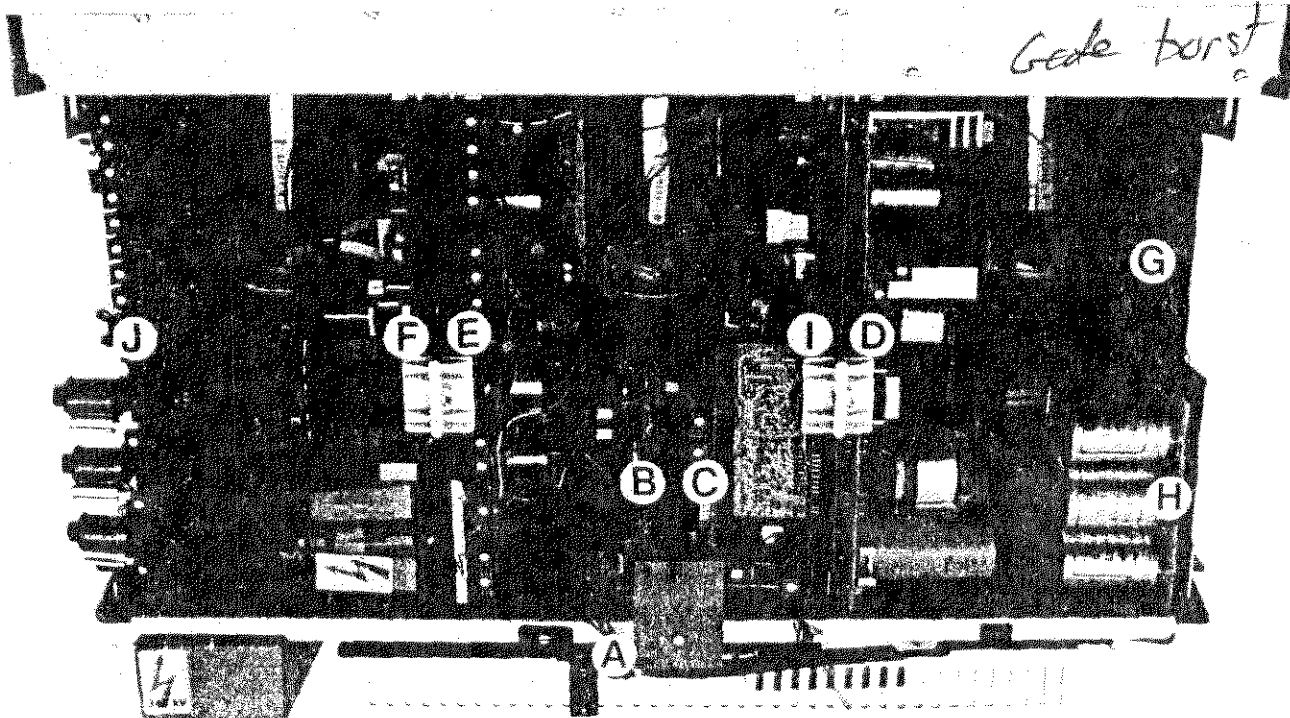

POWER INPUT BOARD
ADAPTATION POWER INPUT : 110V AC OR 220V AC

Adaptation of the projector for 110V AC or 220V AC operation.

- Procedure :
1. Switch OFF the projector.
 2. Remove the top cover to access the POWER INPUT BOARD.
 3. Pull the MAINS INPUT selector from its connector and re-insert it into the connector according to the inscription on the board.

Fig. 1 : 220V AC operation

Fig. 2 : 110V AC operation

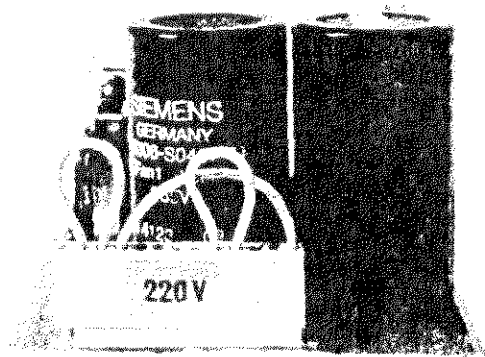

Fig. 1 220V AC

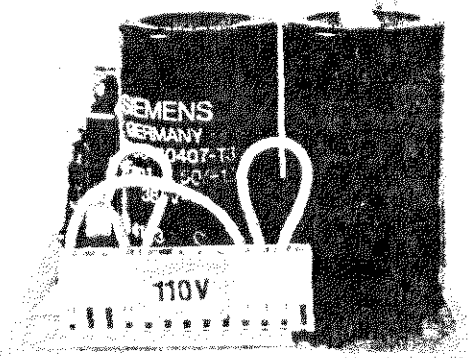
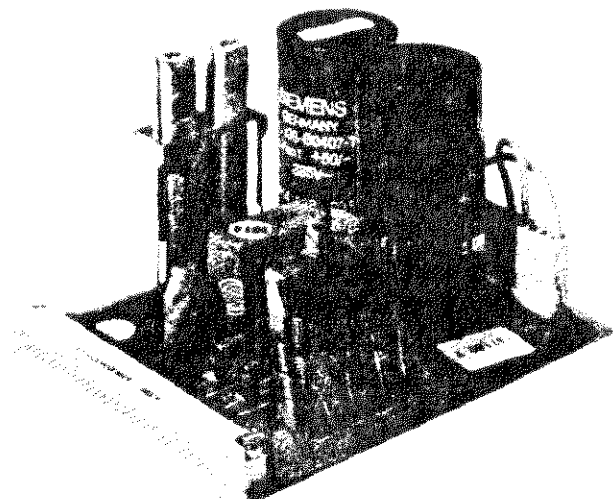

Fig. 2 110V AC



Fuses :

CAUTION

For continued protection against fire hazard

- replace with the same type of fuse

- refer replacement to qualified service personnel

F1 F2

(2x)

4A/250V slow

Barco ord. n°

31 41041

ELECTRICAL CONNECTIONS

A. POWER

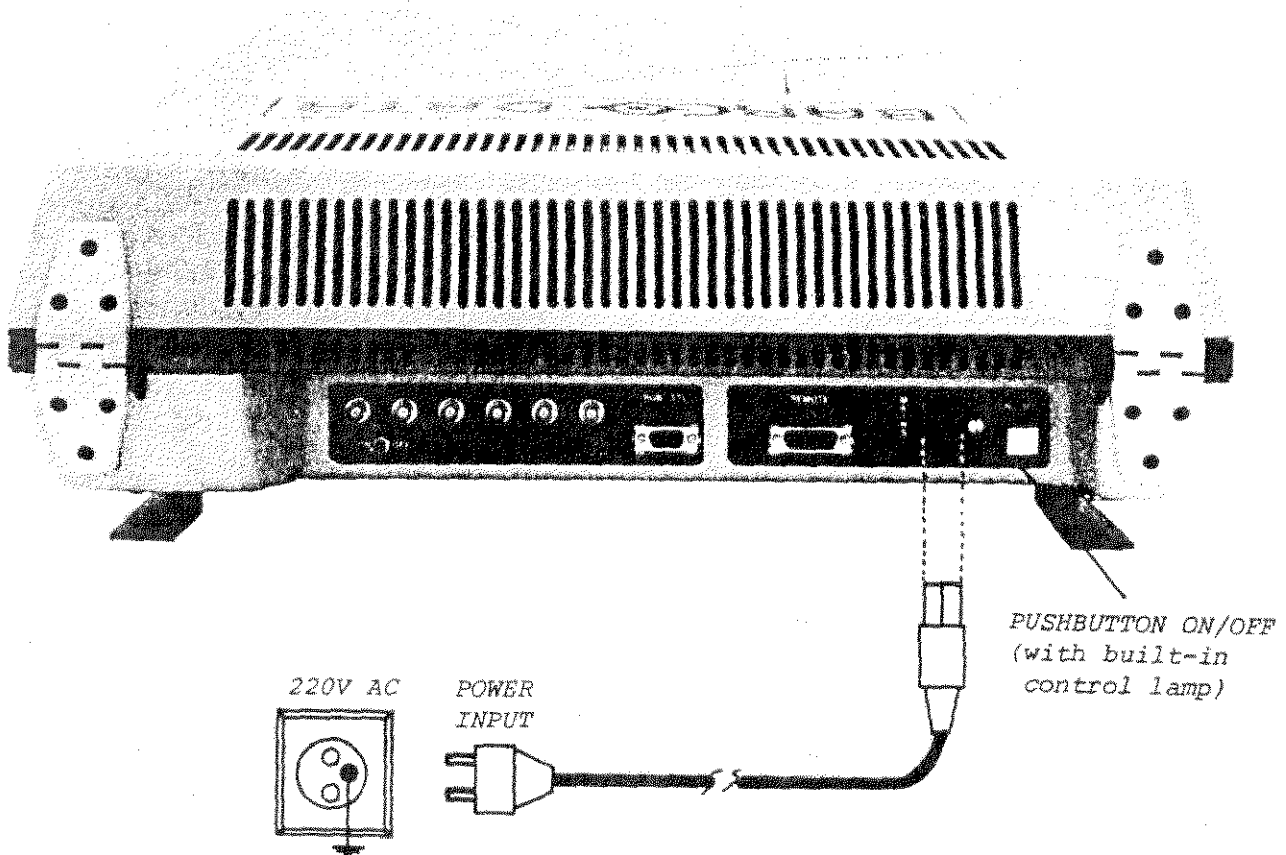

With the projector switched OFF, attach the line cord to the projector and a 220V AC power source.

NOTE : For nominal 110V AC operation, see "INPUT POWER BOARD" for internal plug change procedure.

SWITCHING ON/OFF : The projector is switched ON and OFF using the power switch  ON  OFF. The built-in control lamp indicates the operation mode.

B. CONTROLS

Plug the CONTROL/SWITCH BOX 79 15516 into the 15 pin connector on the projector or use the remote cable for the CONTROL/SWITCH BOX connection.

CONTROL/SWITCH BOX plugged in on the projector.

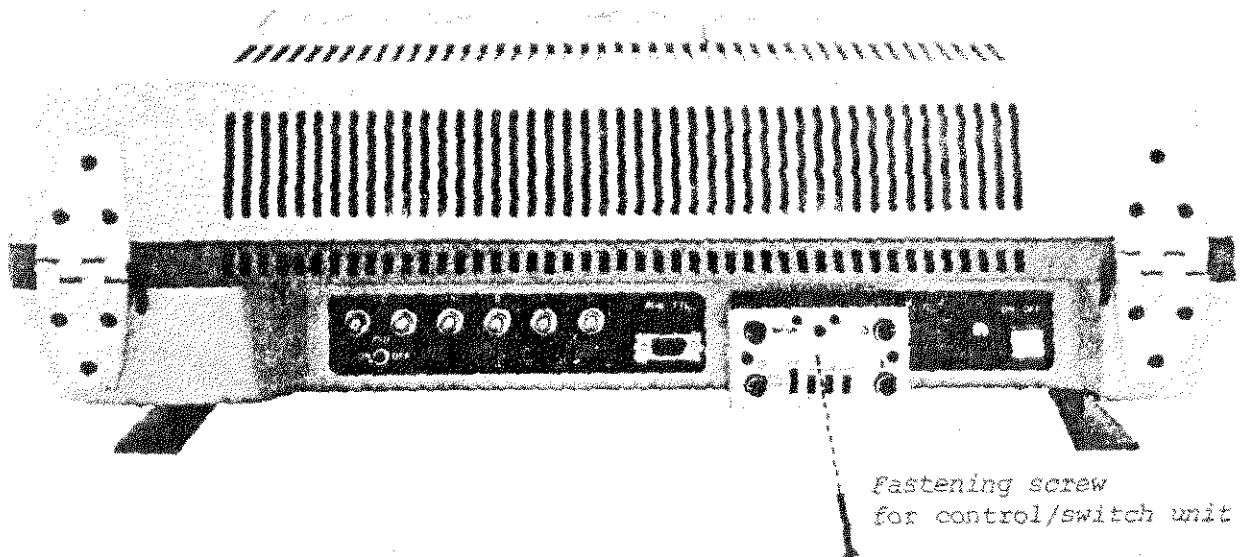

CONTROL/SWITCH BOX connected with projector using remote cable.

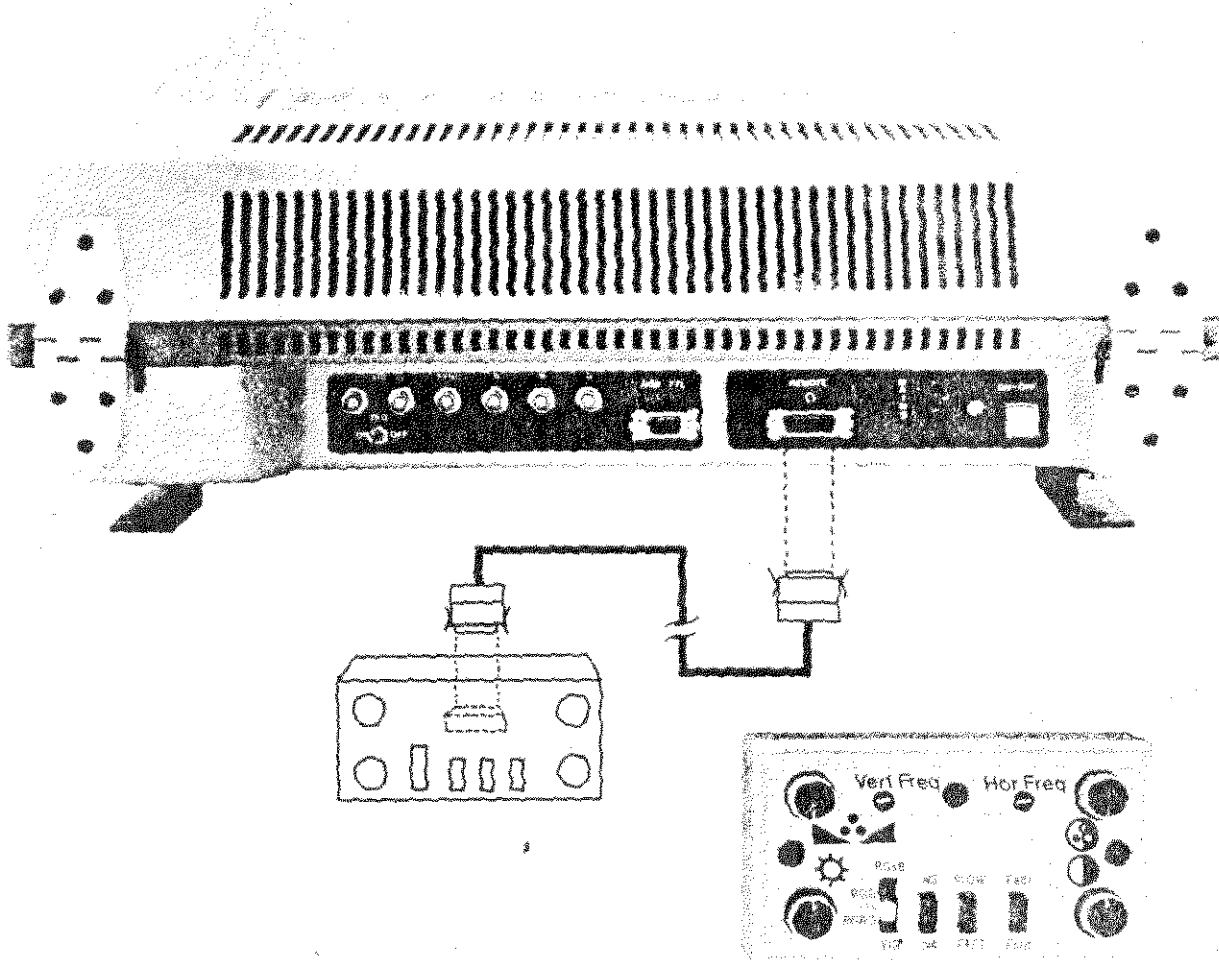

C. SIGNAL PROCESSING

1. Input signal : VIDEO COMPOSITE

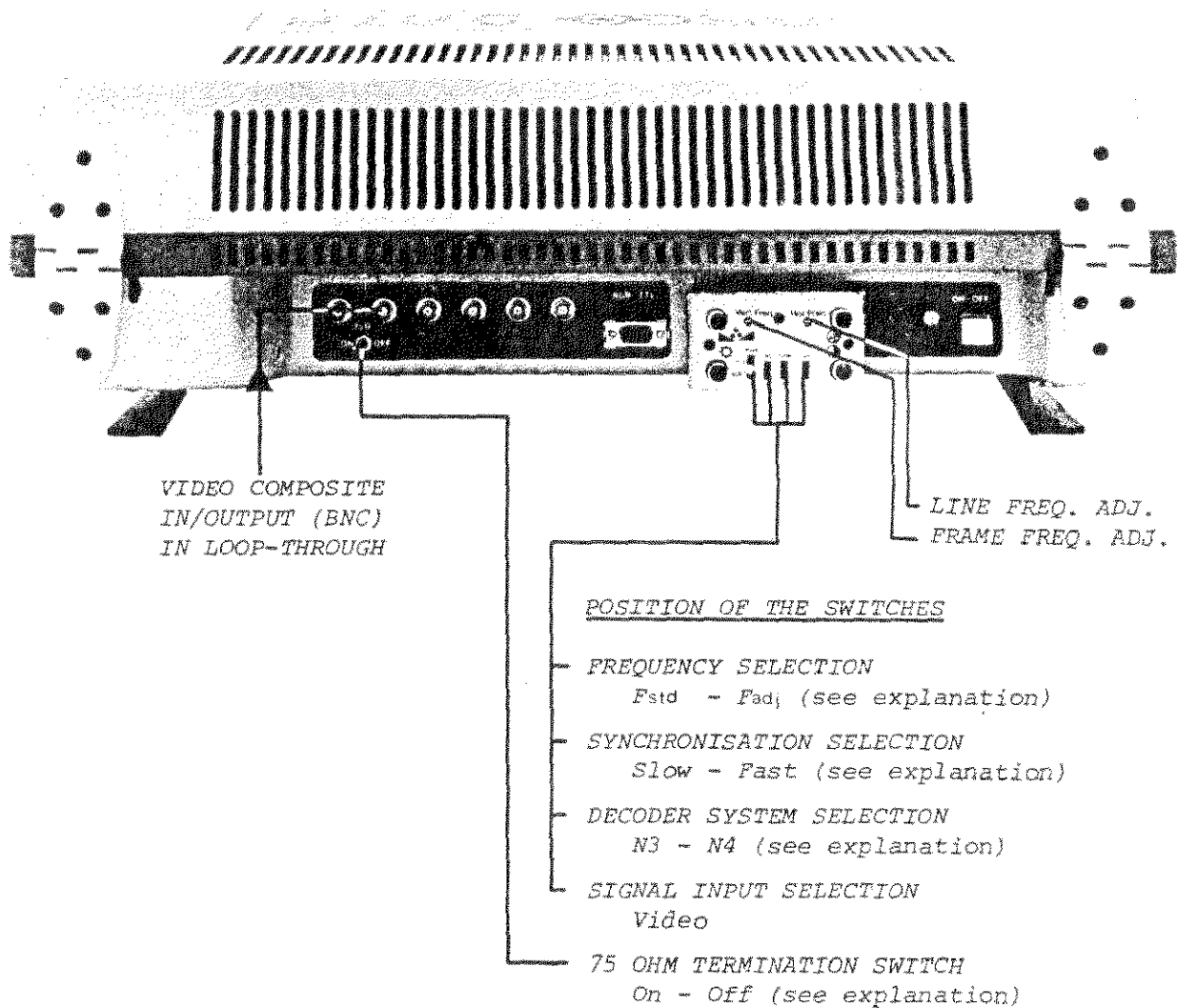

Video composite signal :

Attach a composite video source using a coaxial cable with a BNC connector.

Frequency range selector :

Position Fstd : Frequency Range 1 : Line / Frame frequency

15625 Hz	50 Hz
15750 Hz	60 Hz

(presetable on the Sync + Vert. Defl. board)

Position Fadj : Frequency Range 2 : Line frequency : 15625 Hz upto 32 kHz
Frame " : 50 Hz upto 110 Hz

(continuously adjustable with the two freq. controls on the Control/Switch Box)

75 Ohm termination switch :

Terminate the projector input using the 75 Ohm/Hi-Z switch between the input loop-through connectors, if the unit is the only one on the video cable or the last unit in a string. To terminate put the switch in the 75 Ohm position.

Decoder selection :

N4 : PAL, SECAM or NTSC 4.43 is automatically selected.

(NTSC 4.43 : for playback of an NTSC recorded video tape with a video tape recorder/player specially designed for use with the NTSC 4.43 system).

N3 : PAL, SECAM or NTSC 3.58 is automatically selected.

(NTSC 3.58 : for playback of an NTSC 3.58 video signal from e.g. an external TV receiver/decoder, video tape recorder 3.58, etc).

Synchronisation selection :

SLOW : playback decoded OFF AIR signals.

FAST : playback VIDEO signals from e.g. video recorders.

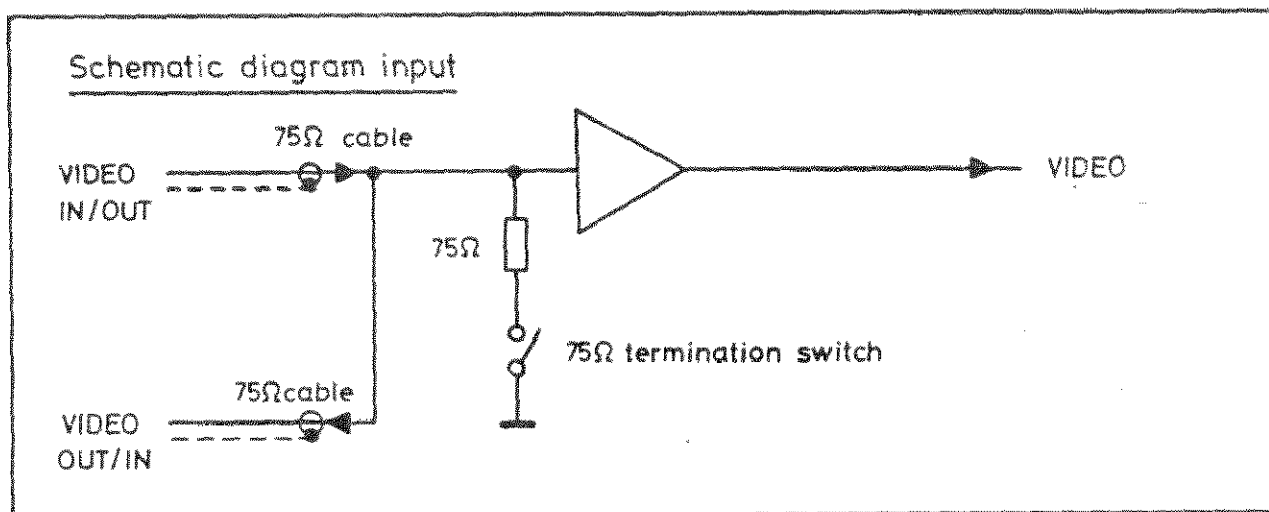

2. Input signal : RGB Analog or RGB TTL

Allows a character generator, micro computer, video camera or a special adapter for videotext/teletext having digital (RGB TTL) or analog (RGB Analog) RGB outputs.

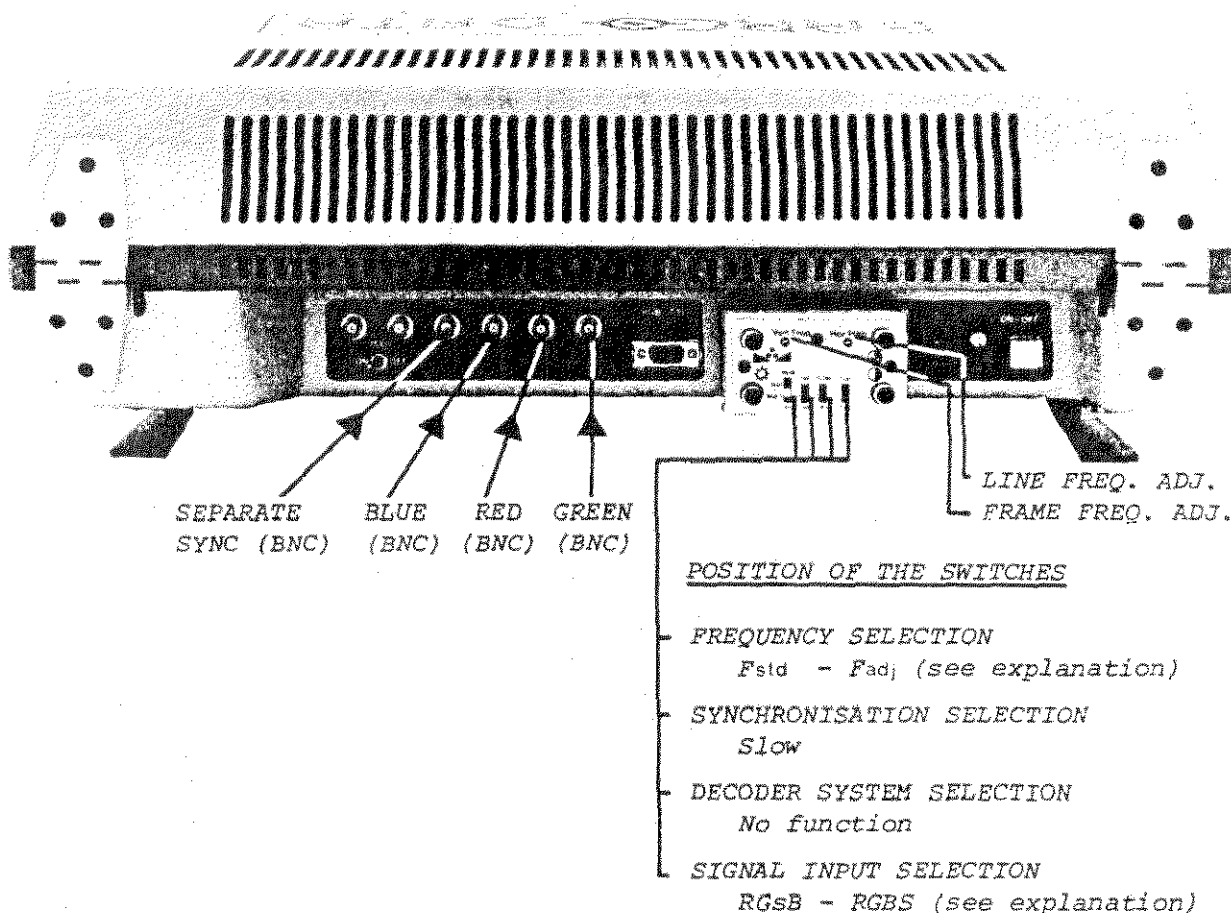

RGSB or RGB+S input signals :

Selection : RGSB : RGB input signals with sync on Green.

RGB+S : RGB input signals with separate sync signal.

Attach the RGSB or RGB+S source signals using coaxial cables with a BNC connector.

Frequency range selector :

Position Fstd : Frequency Range 1 : Line / Frame frequency

15625 Hz 50 Hz
 15750 Hz 60 Hz

(presetable on the Sync + Vert. Defl. board)

Position Fadj : Frequency Range 2 : Line frequency : 15625 Hz upto 32 kHz
 Frame " : 50 Hz upto 110 Hz

(continuously adjustable with the two freq. controls on the Control/Switch Box)

On the RGB Analog board the following switches are provided for :
 (attainable when the top cover is opened)

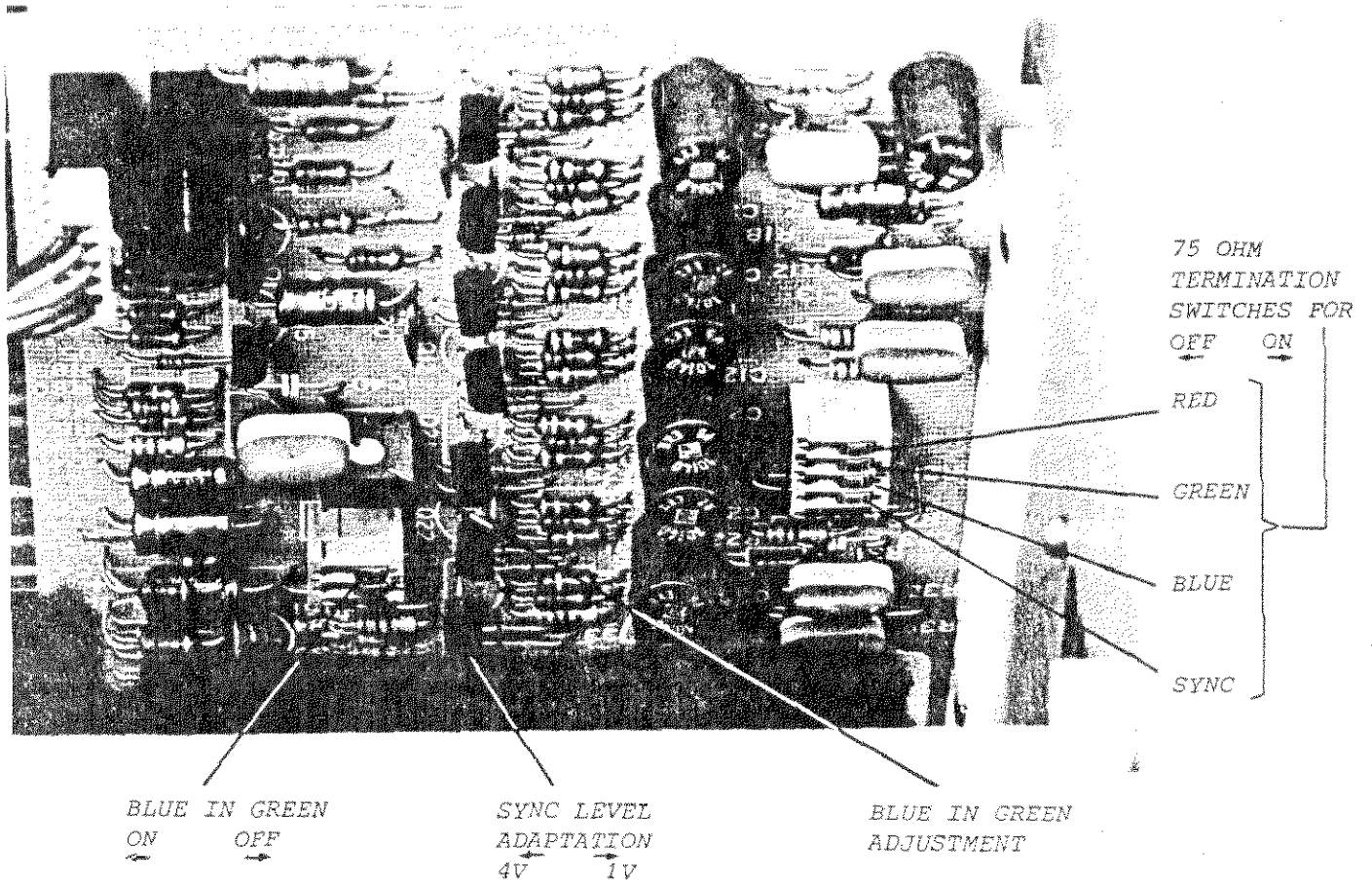

75 Ohm termination switches :

The R, G, B and sync inputs of the projector must be 75 Ohm terminated using the 75 Ohm/Hi-Z switches (ON position).

In case of a loop-through connection, using T-BNC connectors on the respective inputs, the termination switch 75 Ohm/Hi-Z must be put in the 75 Ohm position if the set is the LAST unit in the string.

Sync level adaptation switch :

The separate sync input accepts normally a sync level of 4 Vpp (switch in the 4V position).

If the sync signal is about 1 Vpp, the input is adapted for that level putting the switch in the 1V position.

Blue in Green switch :

Display of characters in uniform Blue is in most cases very difficult to read.

In order to improve the character visibility on the screen, put the switch "Blue in Green" in the ON position. The blue colour will be changed in cyanic, giving a better character visibility (proportion Blue in Green is adjustable).

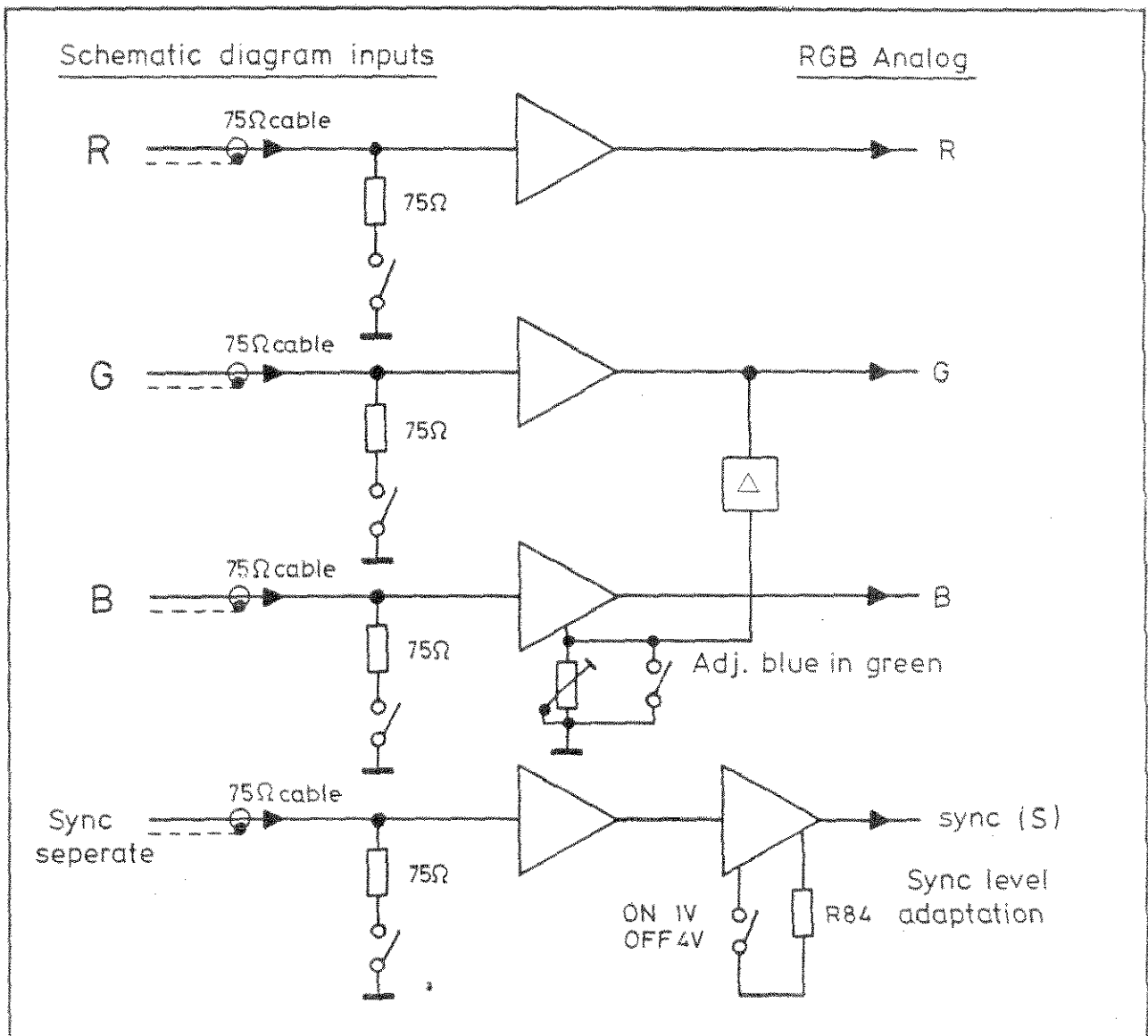

2b. RGB TTL input

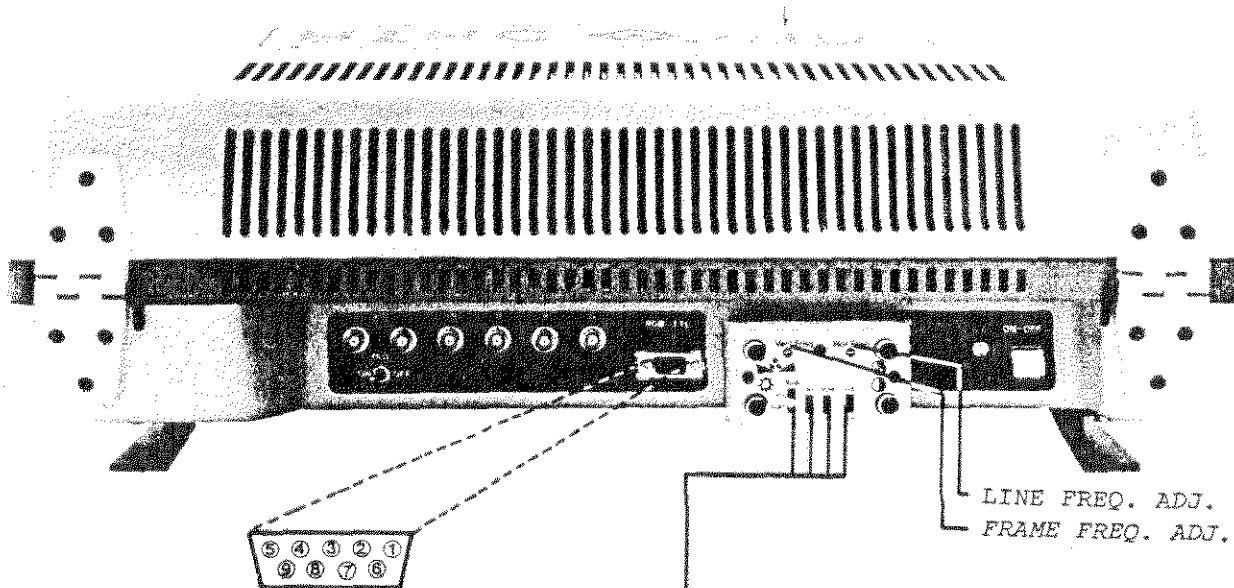

Input D-connector

- 1 Red
- 2 Green
- 3 Blue
- 4 1
- 5 1
- 6 Sync composite
- 7 High-Low
- 8 H-sync
- 9 V-sync

POSITION OF THE SWITCHES

- FREQUENCY SELECTION
Fstd - Fadj (see explanation)
- SYNCHRONISATION SELECTION
Slow
- DECODER SYSTEM SELECTION
No function
- SIGNAL INPUT SELECTION
RGB-TTL

Frequency range selector :

Position Fstd : Frequency Range 1 : Line / Frame frequency
 15625 Hz 50 Hz
 15750 Hz 60 Hz

(presetable on the Sync + Vert. Defl. board)

Position Fadj : Frequency Range 2 : Line frequency : 15625 Hz upto 32 kHz
 Frame " : 50 Hz upto 110 Hz

(continuously adjustable with the two freq. controls on the Control/Switch Box)

On the RGB TTL board the following switches are provided for :
 (attainable when the top cover is opened)

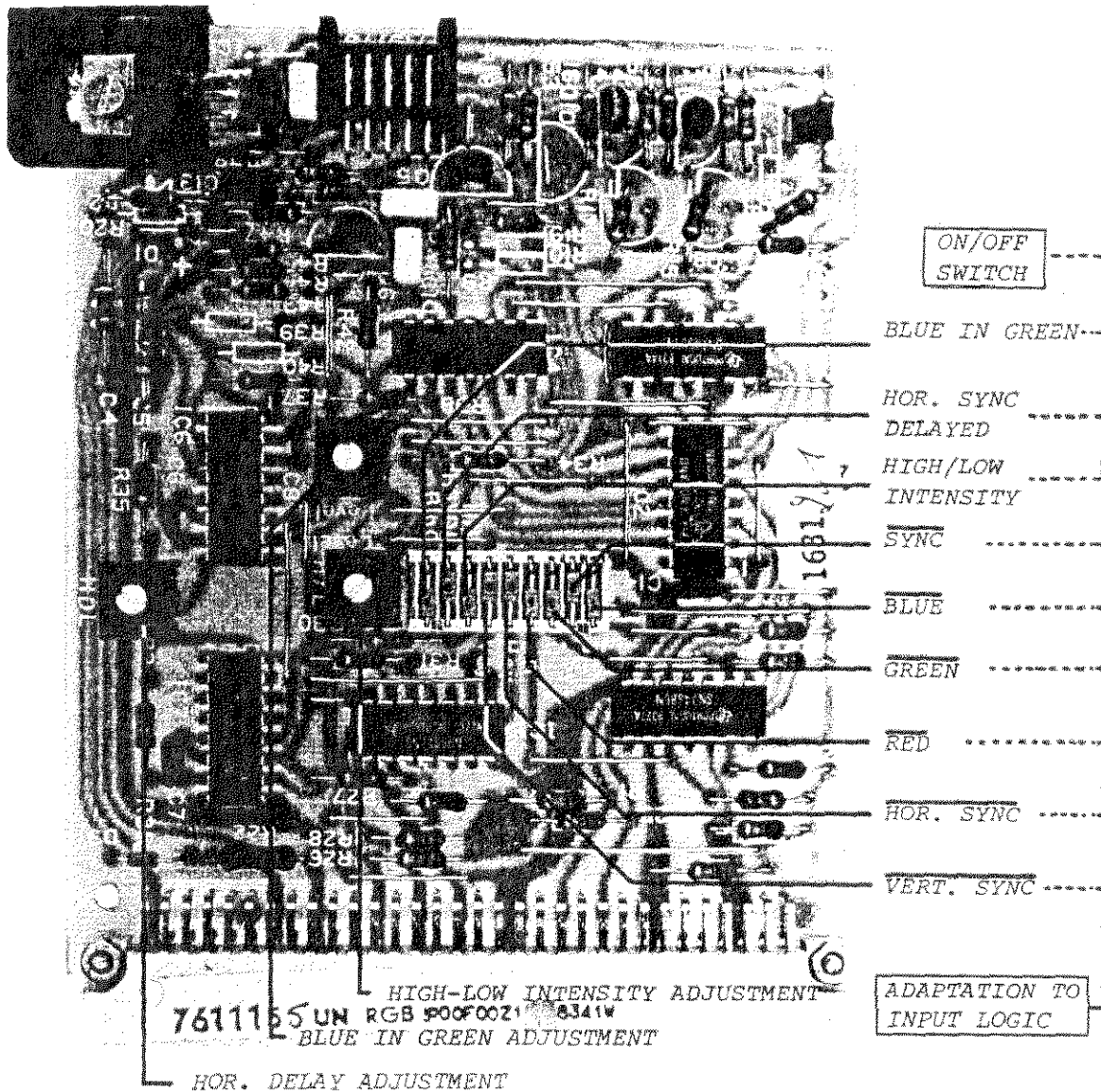

Explanation of the input possibilities :

1. TTL input signals : Red (pin 1)
Green (pin 2)
Blue (pin 3)
Composite sync (pin 6)

Switches 1 to 4 : allows an adaptation of the E-OR input with regard to the computer logic (pos. or neg.).

2. TTL input signals : Red (pin 1)
Green (pin 2)
Blue (pin 3)
Separate sync : Vert. sync (pin 9)
Hor. sync (pin 8)

Switches 1-3-4 : allows an adaptation of the E-OR input for the colour signals with regard to the computer logic (pos. or neg.).

- Switch 2 : allows an adaptation of the E-OR input for the composite sync signal with regard to the computer logic (pos. or neg.).
- Switch 5-6 : allows an adaptation of the E-OR input for the separate sync signals with regard to the computer logic (pos. or neg.).
- Switch 8 : Hor. sync delay YES or NOT.
In case of a not usual hor. & vert. sync signal, this switch has to be put in the OFF position.
As reference the hor. & vert. input signal, a logic circuit on the board will deliver hor. & vert. sync pulses for correct synchronisation. The position of the hor. sync pulse is adjustable with the potentiometer "Hor. delay time".
- Switch 9 : Blue in Green : YES or NOT (same function as on the RGB Analog board).
- Switch 7 : allows an adaptation of the E-OR input for the H/L info with regard to the computer logic.

High/Low intensity info :
Computer signal, applied to the High/Low intensity input, commands the BARCO projector to display the respective characters in a higher intensity (H/L intensity level is adjustable with the potentiometer "H/L intensity adj.").

Note : E-OR indicates exclusive-or gate circuitry.

Schematic diagram inputs

RGB-TTL

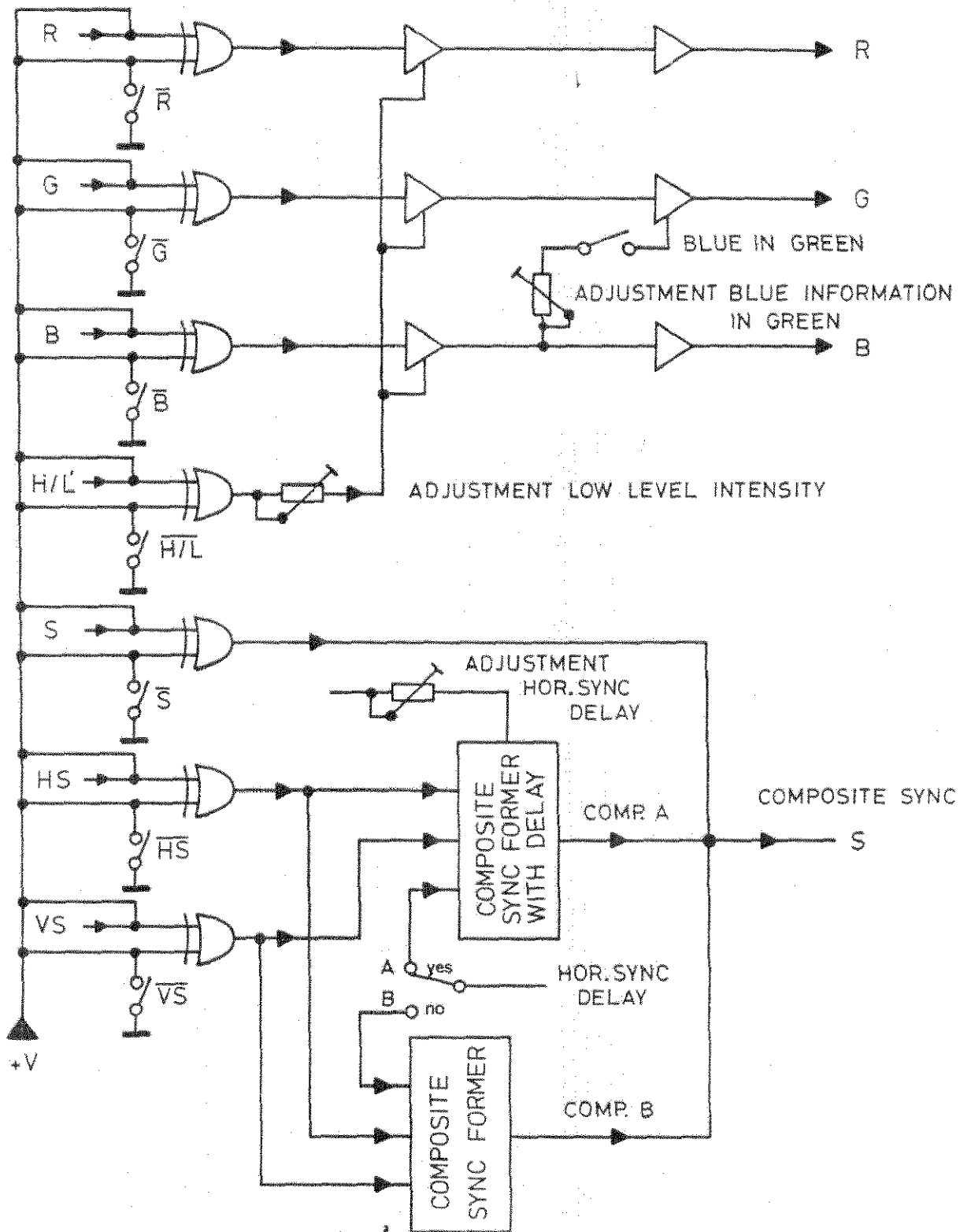

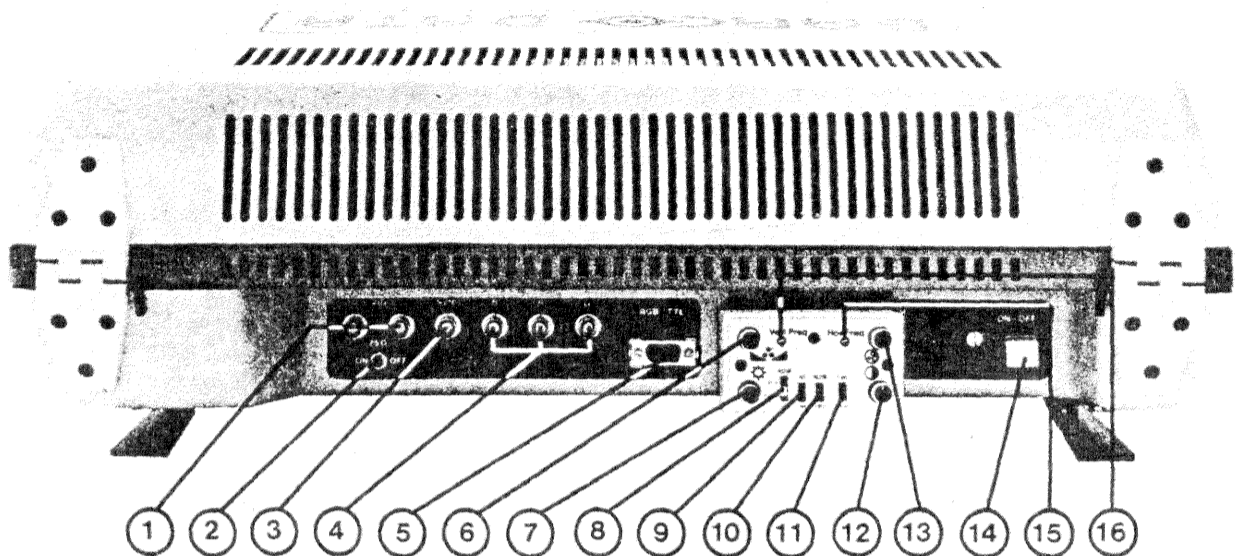

1. SWITCHING ON-OFF THE PROJECTOR

Press the power switch (14) to bring the projector into operation. The built-in pilot lamp will light.
To switch OFF, press the power switch again.

2. SELECT THE DESIRED PROGRAM AS FOLLOW :

VIDEO (VID) : For a program source connected to the VID input (1).

- Switch (8) in the VID position.
- Switch (2) in the ON position (75 Ohm terminated) in a non-loop-through connection.
- Switch (9) and (10) :

a) Automatic colour system selection (9)

N4 : PAL-SECAM or NTSC 4.43 is automatically selected

(NTSC 4.43 : for playback of an NTSC-recorded video tape with a video tape recorder /player specially designed for use with the NTSC 4.43 system).

N3 : PAL-SECAM or NTSC 3.58 is automatically selected

(NTSC 3.58 : for playback of an NTSC 3.58 video signal from an external TV receiver/decoder, video tape recorder 3.58, etc.).

b) Synchronisation speed selection ⑩

- playback OFF AIR signals : select SLOW position.
- playback VIDEO signals from e.g. video recorder : select FAST position.

RGsB : For a program source connected to the RGB Analog input ④.
RGB+S

- Switch ⑧ in the RGsB position for RGB signals with sync on green.
- Switch ⑧ in the RGB+S position for RGB signals with separate sync (separate sync input ③).
- Switch ⑩ in the SLOW position.

RGB TTL : For a program source connected to the RGB TTL input ⑤.

- Switch ⑧ in the RGB TTL position.
- Switch ⑩ in the SLOW position.

3. TURN ON THE CONNECTED EQUIPMENT

The picture will be projected on the screen.

4. ADJUST THE PICTURE TO YOUR PREFERENCE

Important : playback RGB signals : picture is controlled only by the Brightness and Contrast control.

BRIGHTNESS ⑦ and CONTRAST ⑫ controls :



Correct brightness and contrast settings are important for good colour reproduction.

Brightness ⑦ : adjust brightness control so that the darkest parts of the picture appear as black.

Contrast ⑫ : adjust contrast from the lowest setting to the desired level according to your preference and room lighting conditions.

(Note : don't overdrive into "smearing").

COLOUR CONTROL ⑬



Adjust the colour intensity of the picture. Clockwise rotation makes the picture vivid; counter-clockwise rotation makes it pale.

TINT CONTROL (HUE) ⑥



This control is effective only when playing an NTSC-recorded tape using the NTSC 4.43 system or playback NTSC 3.58 video signals. Clockwise rotation makes the skin tones greenish; counter-clockwise rotation makes them purplish. Adjust the tint to give the most natural skin tones.

5. ADAPTATION OF THE BARCODATA TO THE LINE AND FRAME FREQUENCY OF TWO INPUT SOURCES : SWITCH (11)
ADJ. CONTROLS (15) AND (16)

Frequency ranges :

RANGE 1

Standard line : 15625 Hz or 15750 Hz 64 us 63.4 us	Switch Fstd/Fadj in the Fstd position
Standard frame : 50 Hz or 60 Hz	

Presetable on the SYNC + VERT. DEFL. of the BARCODATA

RANGE 2

Non-standard line : 15625 kHz to 32 kHz 64 us to 31.2 us	Switch Fstd/Fadj in the Fadj position
Adjustable with control (15)	
Non-standard frame : 50 Hz to 110 Hz	

Adjustable with control (16)

Continuously adjustable on the Control/Switch Box :

Adj. control (15) : Hor. frequency

Adj. control (16) : Vert. frequency

The Switch Fstd/Fadj (11) : allows switching between two different scanning frequencies, one corresponding to line and frame frequencies in RANGE 1 and the other corresponding to line and frame frequencies in RANGE 2.

Adjustment procedure for line and frame frequency in range 2 :

a) Hor. freq. adjustment

- short-circuit capacitor C8 on the SYNC + VERT. DEFL. BOARD.
- adjust HOR. FREQ. control (15) for min. horizontal tearing of the picture.
- remove the short-circuit.

b) Vert. freq. adjustment

- short-circuit capacitor C15 on the SYNC + VERT. DEFL. BOARD.
- adjust VERT. FREQ. control (16) for min. vertical rolling of the picture.
- remove the short-circuit.

SERVICE ADJUSTMENTS AND ALIGNMENTS

After the projector is correctly installed and all electrical connections are made, proceed to the electrical adjustments.

IMPORTANT : Picture geometry and convergence adjustments have to be adjusted at standard line and frame frequency. Switch Fstd/Fadj on the CONTROL/SWITCH box always in the Fstd position.

Preparation :

1. Open the top cover of the projector (see "Top cover removal").
2. Put the VIDEO/TEST switch in the TEST position (Internally generated grid test pattern).

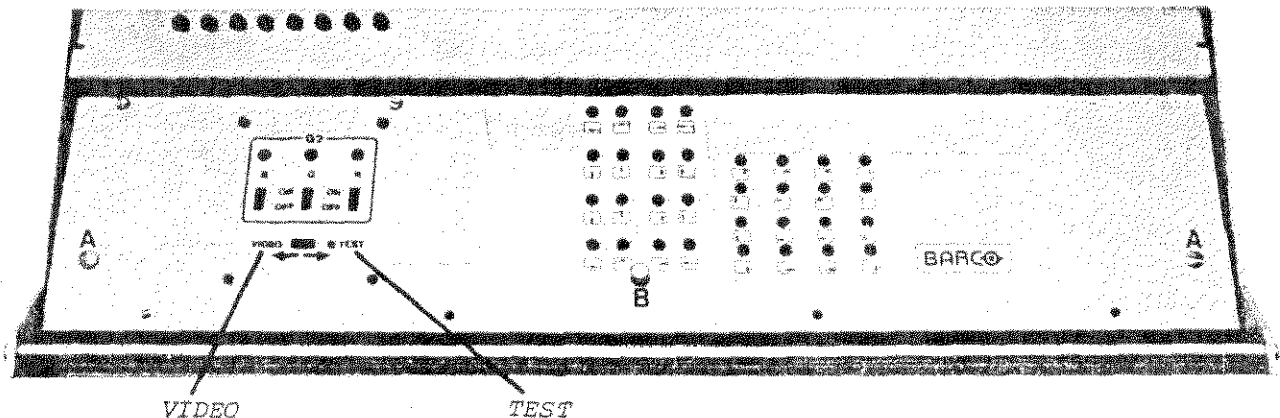

Display video or RGB Signals applied on the respective inputs

Display internally Generated grid test pattern

3. Connect the projector to the power line using the corresponding power cord.
Attention : Before switching ON the projector, always check if the factory set power voltage of the projector corresponds to the power voltage in the room.

A. PICTURE CENTERING

Preparation

Disconnect the convergence board from the motherboard by pulling out the convergence connector.

Proceed as follow (see the above picture) :

- unlock the convergence board by turning both fixation screws A anti-clockwise a quarter of a turn.
- lift up the convergence board using grasp B.
- between the Red and Green picture tube, on the motherboard (frame), the convergence connector is plugged in (follow the convergence cord to locate the right connector).
- pull out the convergence connector and proceed to the following adjustments.

Switch on the projector by pressing the pushbutton ON/OFF.
The built-in control lamp will light up.

1. ON CRT SCREEN

Positioning of the picture display in the center of the CRT screen for each tube :

- place brightness and contrast at a low level, using the brightness and contrast controls.
- while looking into the respective lenses, adjust the potentiometers :
HOR. SHIFT (located on the "N/S + Hor. shift board") and VERT. SHIFT (located on the "Sync + Vert. defl. board") corresponding with each picture tube for the center position of the displayed picture with regard to the screen surface.

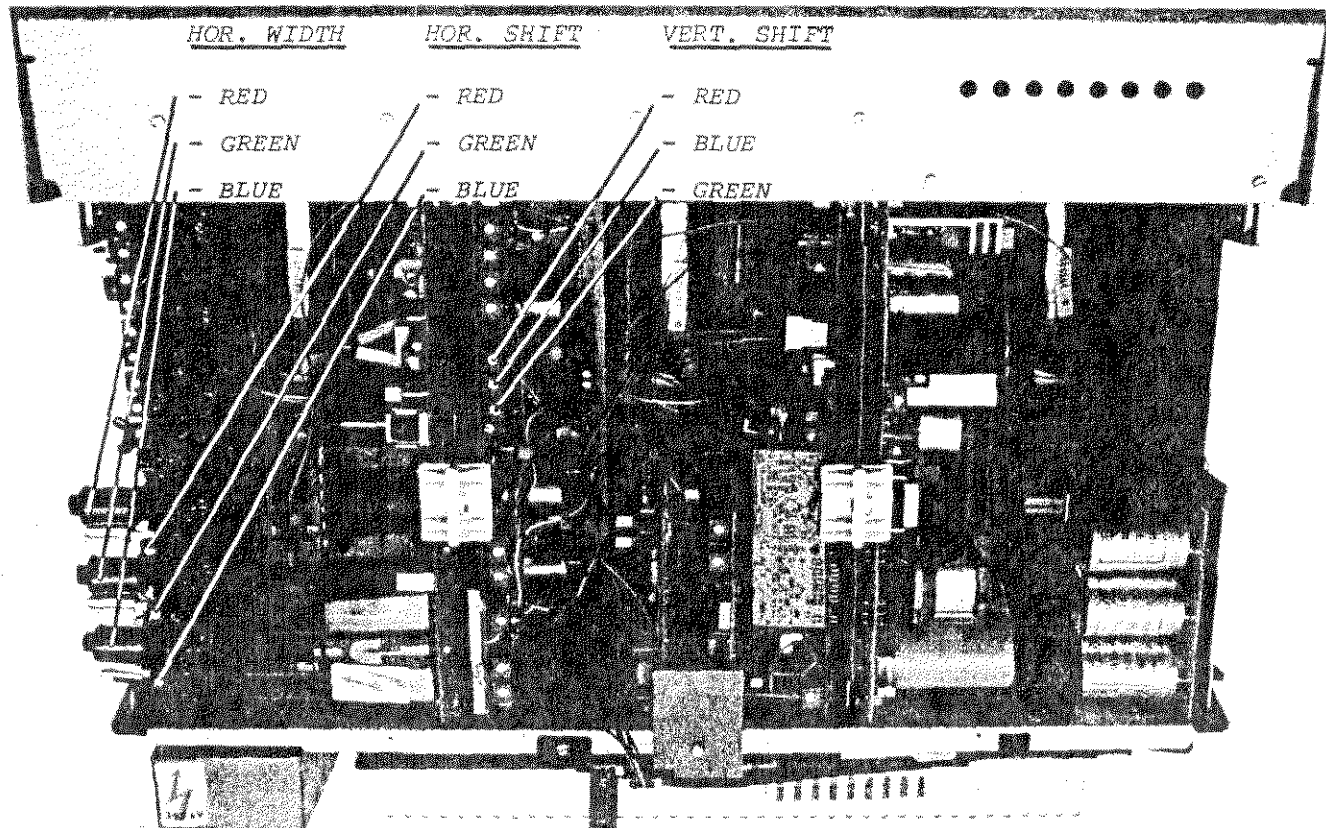
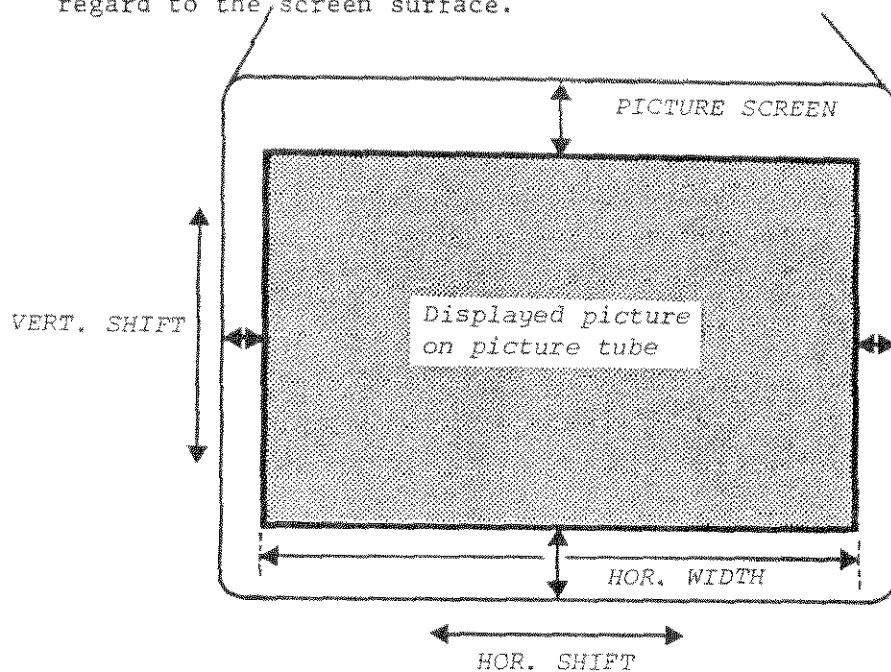

2. ON PROJECTION SCREEN

- Adjust brightness and contrast control for picture display on the screen.
- Proceed to the following adjustments :

Important : In order to accomplish the following adjustments, first proceed to a quick picture sharpness adjustment (see procedure pages 33/34).

- a) Horizontal center lines of the Red and Blue picture do not coincide with these of the Green picture.
This error has to be eliminated by readjusting the VERT. SHIFT potentiometer for Red and Blue until coincidence is obtained.

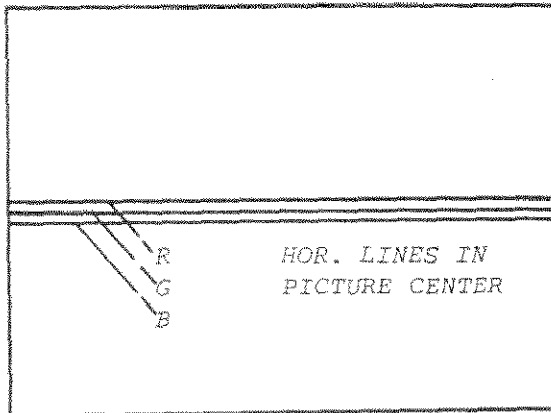

ATTENTION : Referring to the Green picture

If the Green picture is projected too low or too high on the screen surface, first adjust the VERT. shift of Green for correct position of the Green picture on the screen.

Then proceed to the above-mentioned adjustment (2 a)).

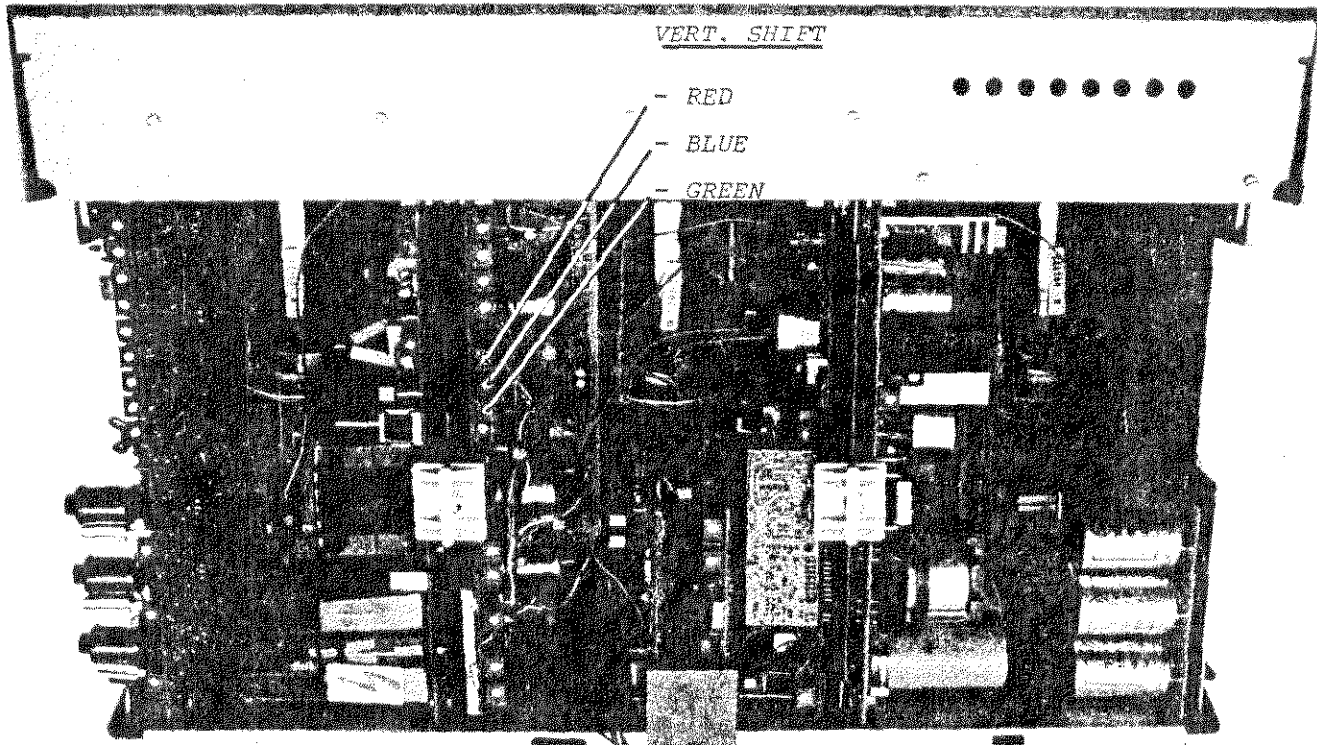

- b) Vertical center line of the Red and Blue picture doesn't coincide with this of the Green picture.
This error has to be eliminated by readjusting the projection angle of the Red and Blue picture tube.

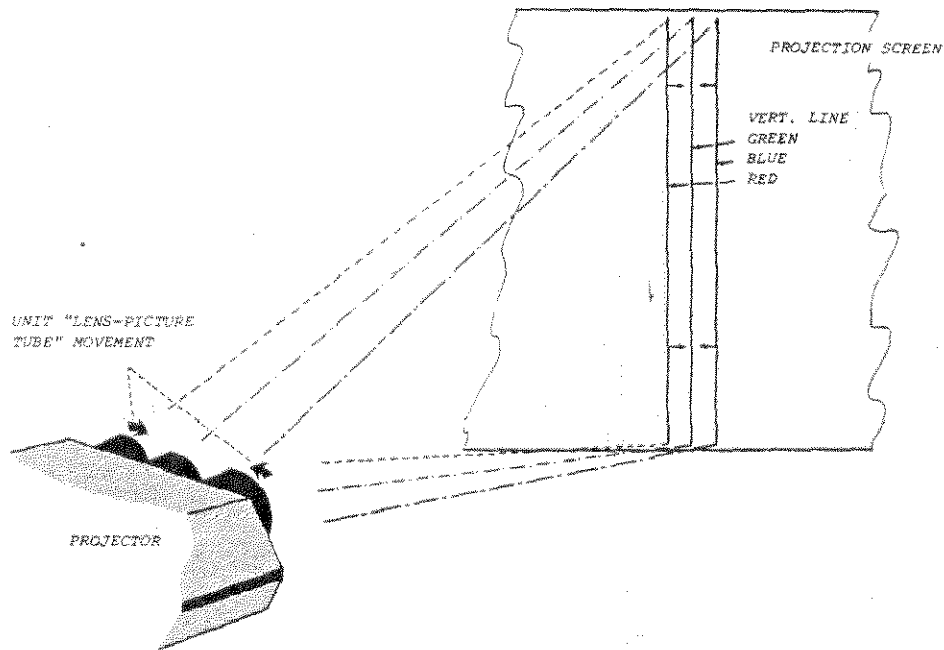

Proceed as follow :

- loosen the four screws (A) fastening the cooling house of the red and blue picture tube.
- now you can move the two outside "lens-picture tube unit" slightly in a horizontal plane.
- proceed to this correction until the vertical center line of the red and blue displayed picture coincides with this of the green.

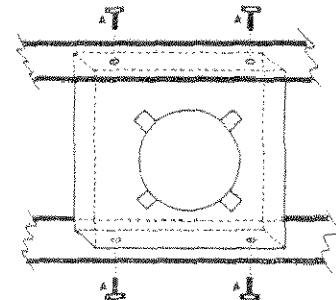
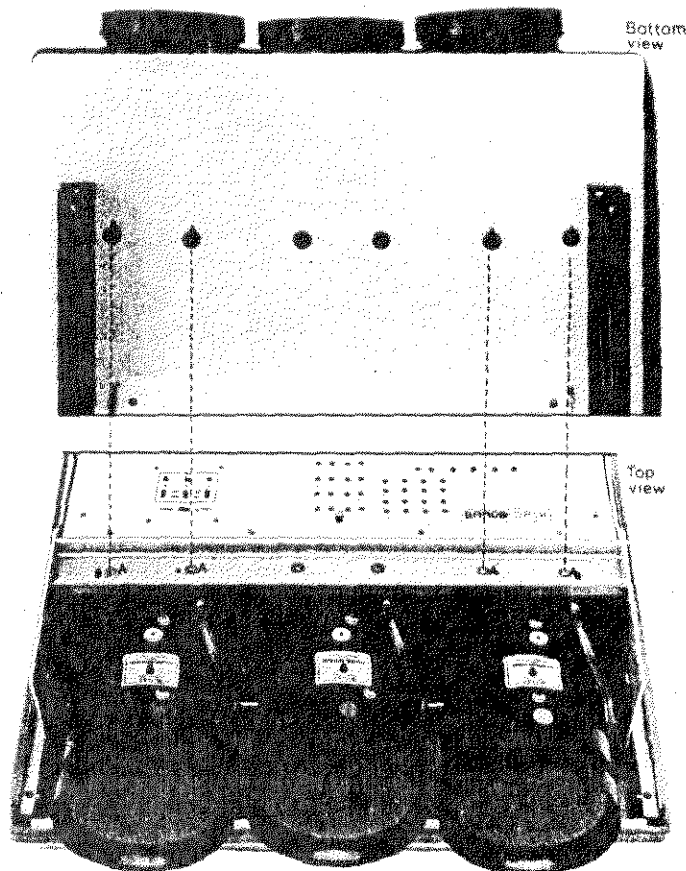

- Secure the right projection angle of the Red and Blue "picture tube / lens" by fastening the corresponding screws A.

a) Common adjustments

These adjustments have to be done only on one colour picture, e.g. green picture, because the other colour pictures are automatically corrected in the same way.

(switch OFF the Blue and Red picture, putting the respective G-2 switch in the OFF position).

1. VERTICAL LINEARITY and AMPLITUDE :

Adjust vert. linearity control for vertical equal size of crosshatch squares on the projected screen.

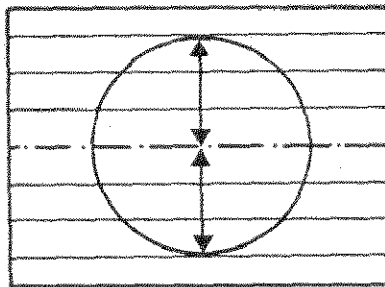

Adjust vertical amplitude control for correct ratio width-height 4 by 3.

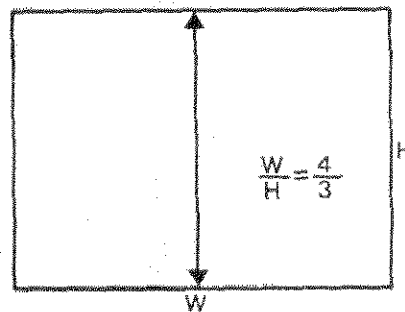

VERTICAL LINEARITY

VERTICAL AMPLITUDE

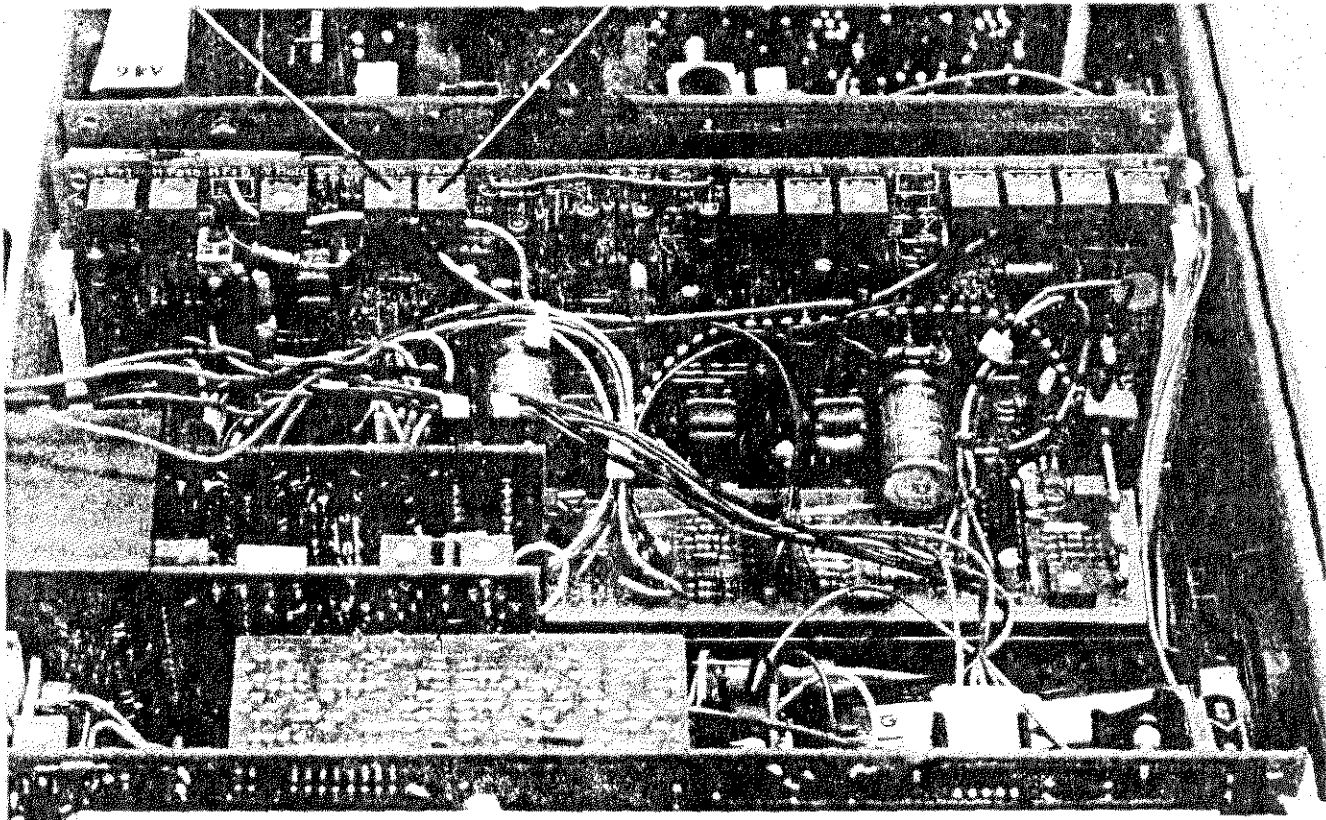

2. HORIZONTAL LINEARITY and AMPLITUDE

IMPORTANT : Before proceeding to the following adjustments, first adjust "Horizontal picture width" (see page 31).

Adjust hor. linearity control for horizontal equal size of the crosshatch squares on the projection screen.

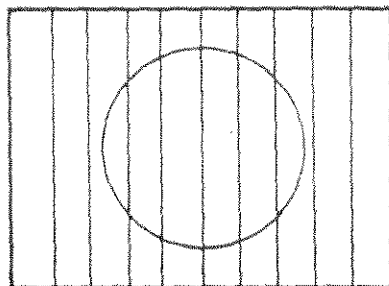

HOR. LINEARITY
L1

Adjust hor. amplitude I control for correct ratio width-height 4 by 3.

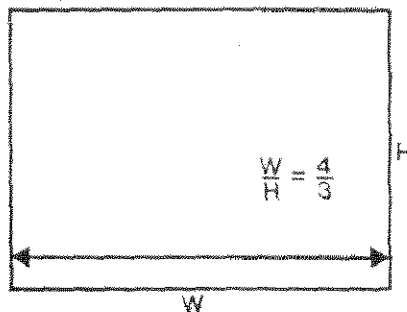

HOR. AMPLITUDE

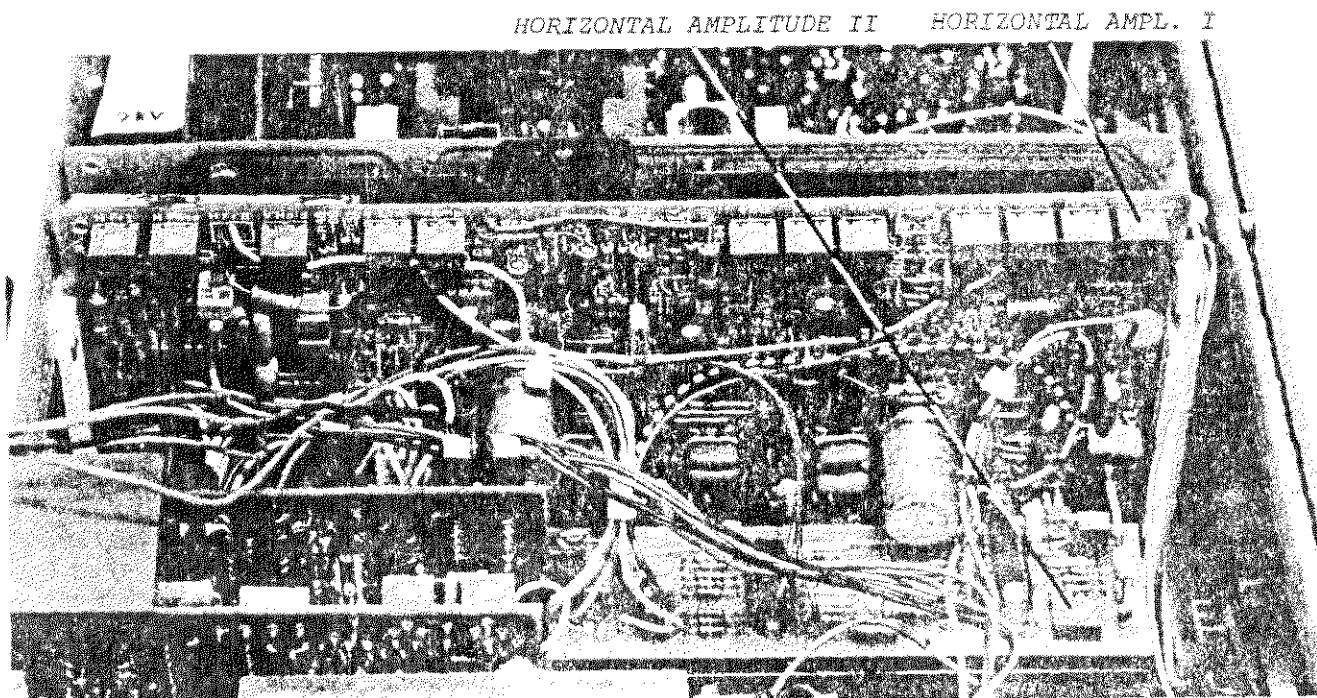
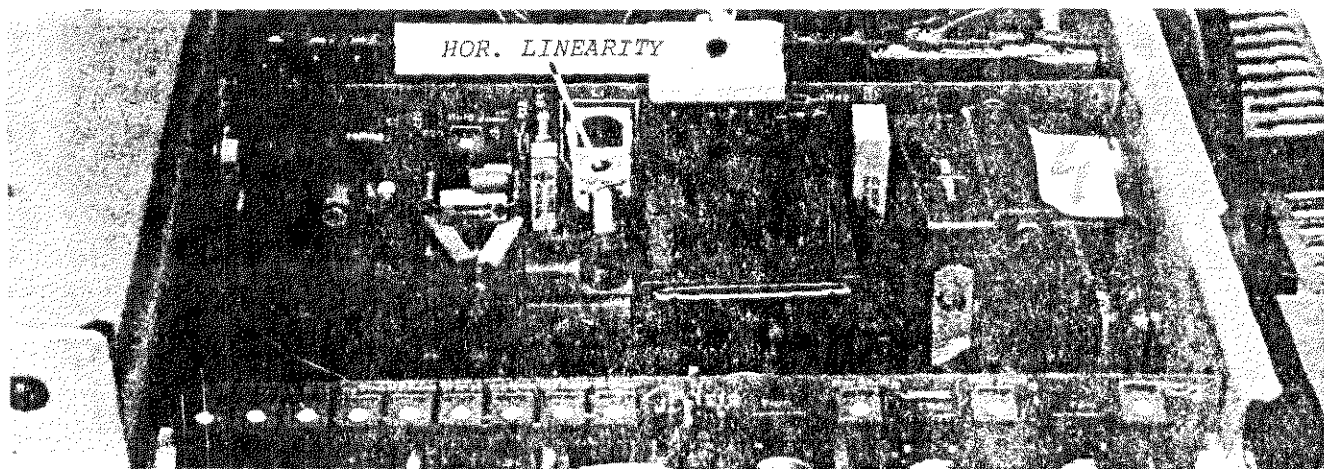

Remark : Adjustment of HOR. AMPL. II (on SYNC + VERT DEFL. BOARD) : correction of the Hor. amplitude in the FII operation mode (to be adjusted on the highest line frequency)

3. Hor. correction : BOW - TRAP. DISTORSION - PCC

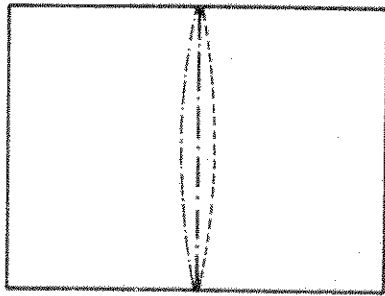

HOR. BOW

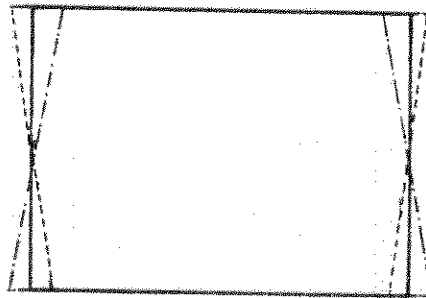

TRAPEZOIDAL DISTORSION

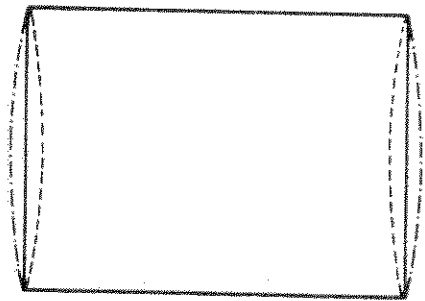

PIN CUSHION CORRECTION

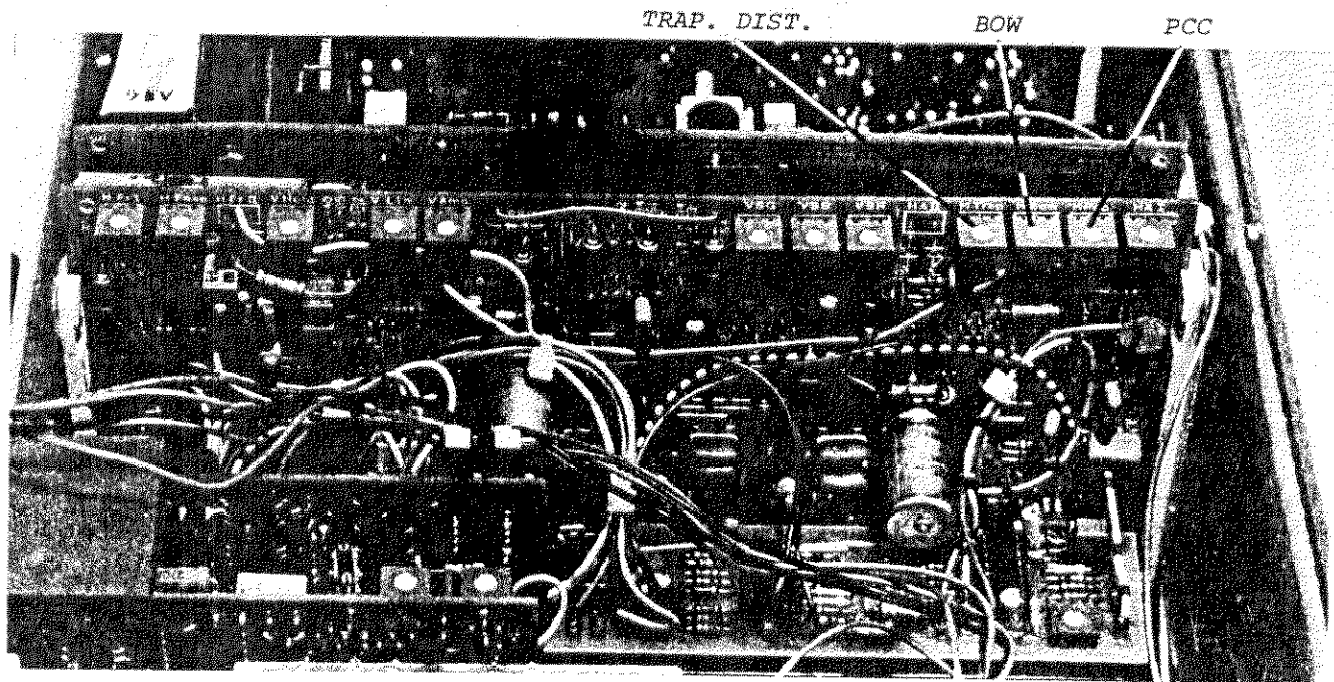

b) Adjustment for each colour picture

The following picture geometry adjustments have to be done separately for each tube.

Important : For the two following adjustments, do not forget to disconnect the convergence board from the motherboard by pulling out the respective connector (see : picture centering).

1. HORIZONTAL PICTURE WIDTH

Adjust the coils T100 for Red, T90 for Green and/or T80 for Blue in order to obtain the same picture width for each projected picture. TAKE CARE THAT ALWAYS ONE OF THE CORES OF THE THREE COILS IS FULLY TURNED IN.

Practical experience : Core of the coil for Red fully turned in. Adjust the two other coils for same picture width as for Red.

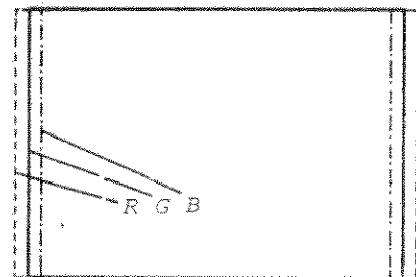

PICTURE WIDTH

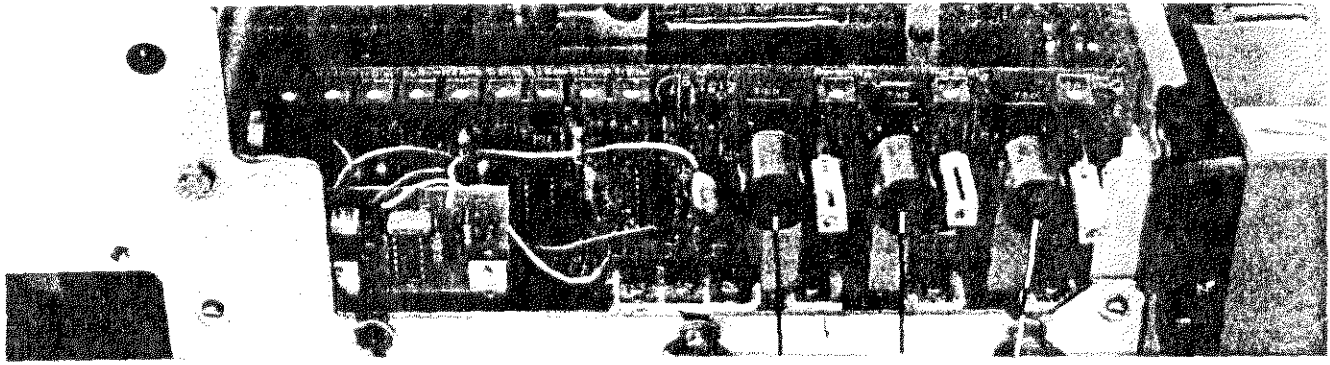

RED GREEN BLUE
HOR. WIDTH

2. Vert. corrections : TRAP. DISTORSION - BOW - NORTH/SOUTH AMPLITUDE

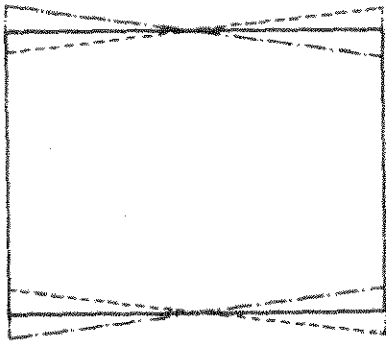

TRAPEZOIDAL DISTORSION

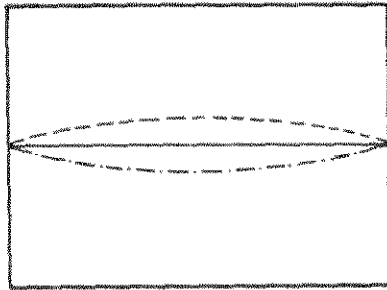

BOW

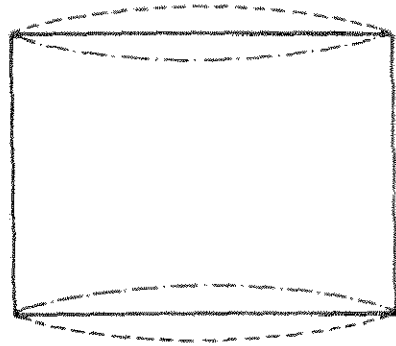

NORTH/SOUTH AMPLITUDE

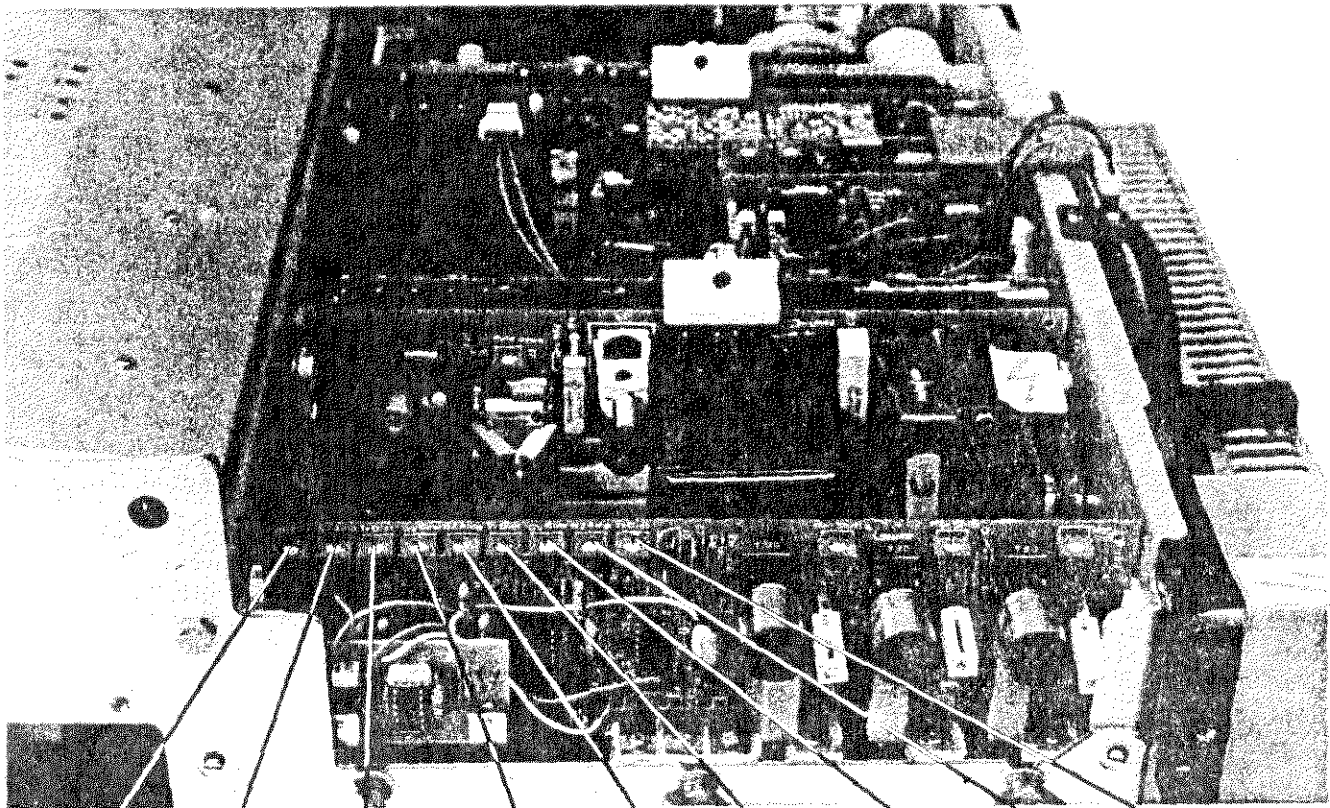

BOW N/S TRAP. DIST. BOW N/S TRAP. DIST. BOW N/S TRAP. DIST.

BLUE PICTURE

RED PICTURE

GREEN PICTURE

C. PICTURE SHARPNESS ADJUSTMENT

The following adjustments have to be done separately for each colour. Each colour picture can be switched OFF by means of the respective G2-switch.

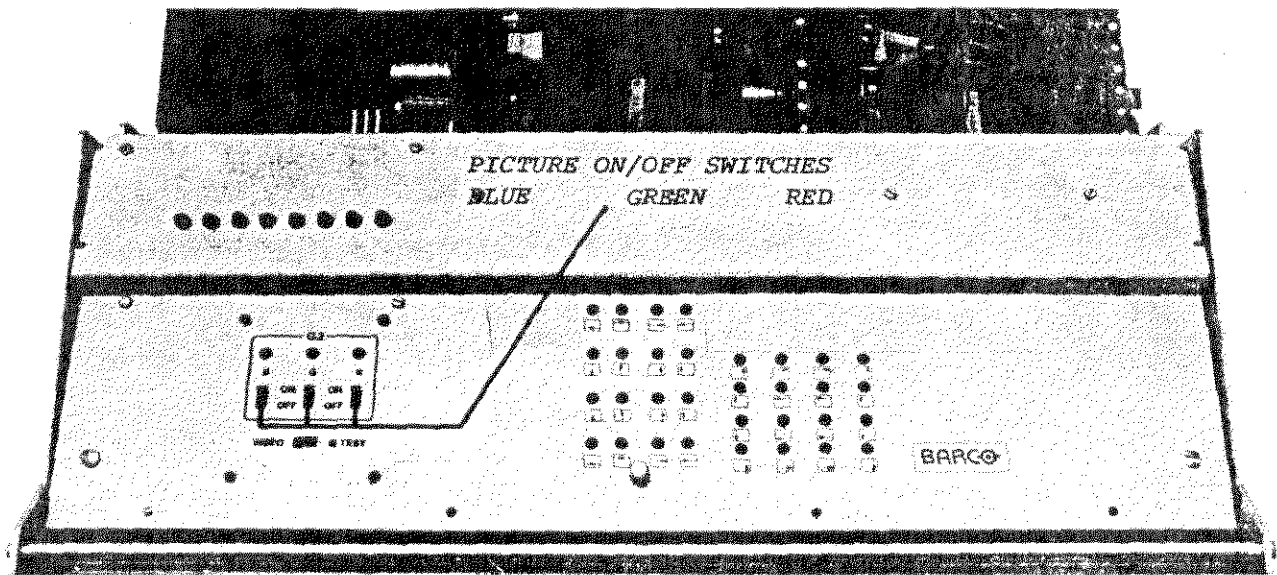

1. Lens focus adjustment

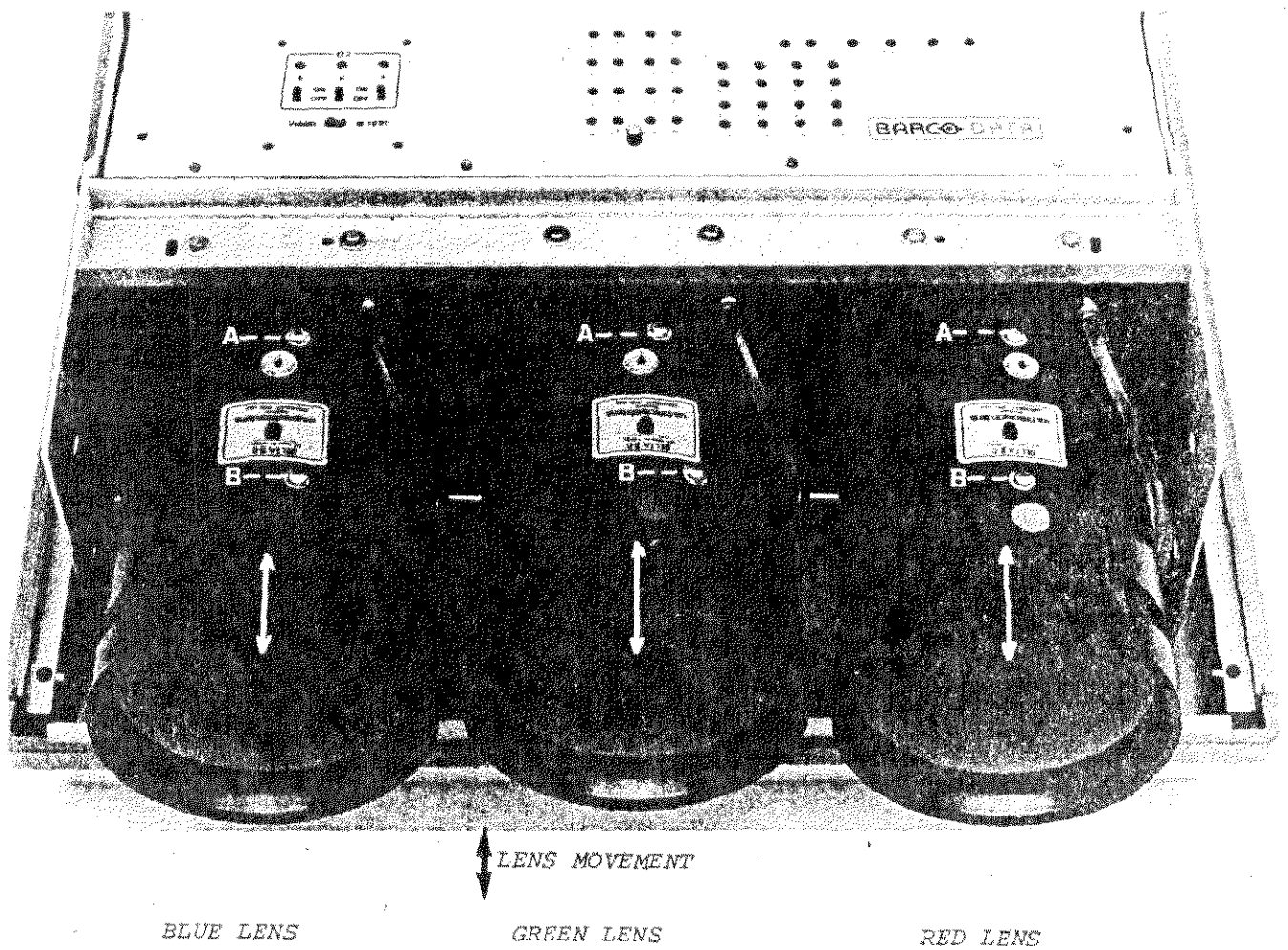

a) *Mechanical focussing in the MIDDLE of the screen*

- loosen screw A on each lens unit (be sure that screw B is fastened).
- adjust the lens of Green, Red and Blue separately for the sharpest picture on the screen.
- secure the exact position of each lens by tightening lens screw A.

b) *Mechanical focussing in the CORNERS of the screen*

- loosen screw B on each lens unit (be sure that screw A is fastened).
- adjust the lens of Green, Red and Blue separately for the sharpest picture on the screen.
- secure the exact position of each lens by tightening lens screw B.

2. *Electrical focussing*

Important : Electrical focus adjustment has to be done with a reduced contrast and brightness level (e.g. contrast and brightness controls in their medium position).

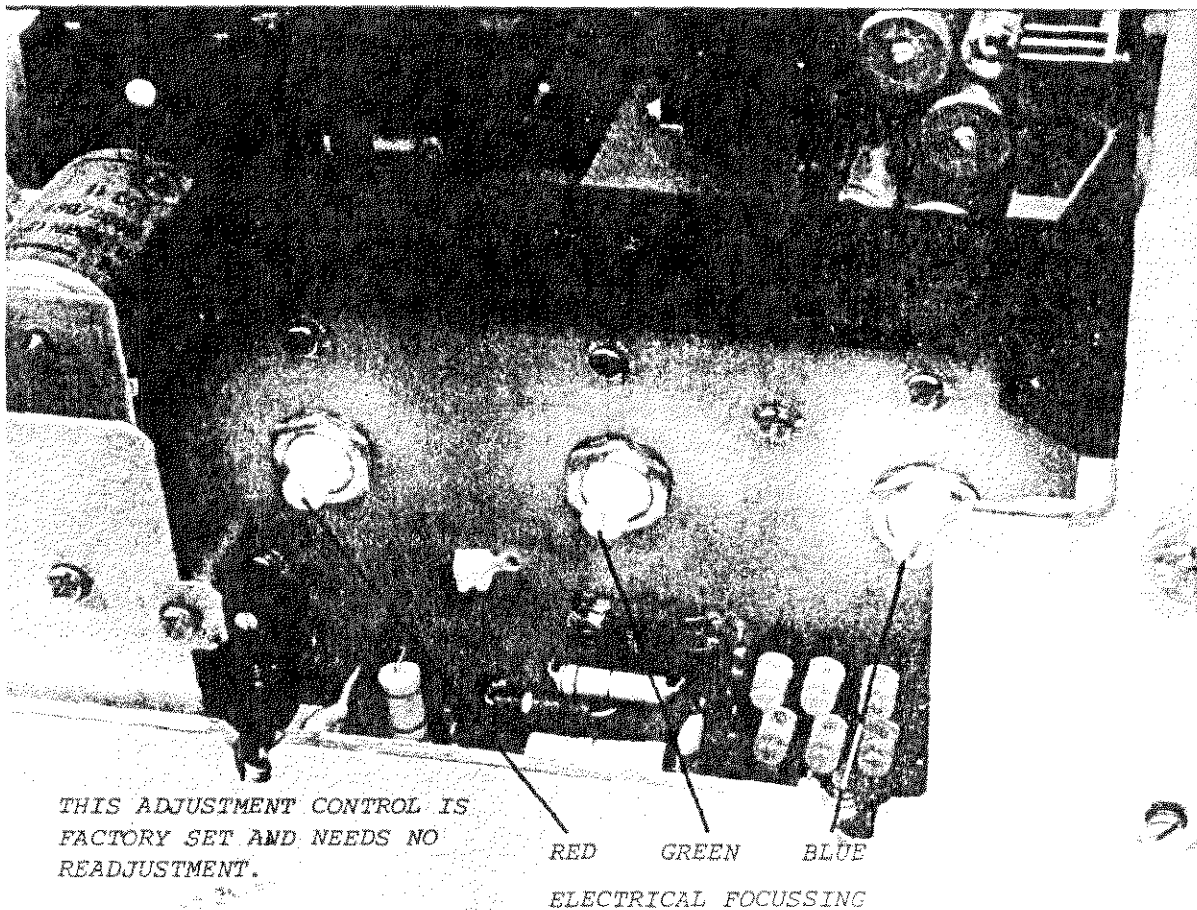

Adjust the focus potentiometer for RED, GREEN and BLUE for sharpest picture on the screen.

NOTE : To be sure that maximum picture sharpness is obtained, look on the screen if scanning lines structure is sharp in the respective area.

D. CONVERGENCE ADJUSTMENT

Before starting the convergence adjustments, let the projector warm up for at least 15 minutes.

Attention ! - If you did follow the "service adjustments and alignments" from the beginning, do not forget now to plug in the convergence connector onto the frame.

- Convergence adjustments have to be done on standard frequency (switch Fstd/Fadj in the Fstd position).

I. Static convergence (center screen)

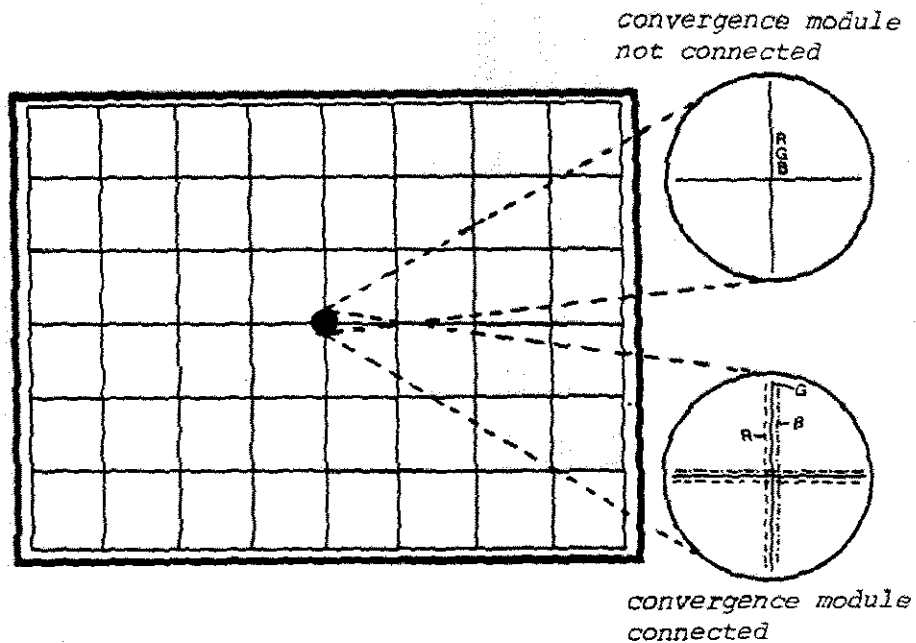

After re-connection of the convergence module to the frame, eventual mis-convergence in the center of the cross-hatch picture can be re-adjusted by means of the vert. & hor. shift controls.

Important : Converge blue and red on green in the center of the picture without touching the shift controls for green.

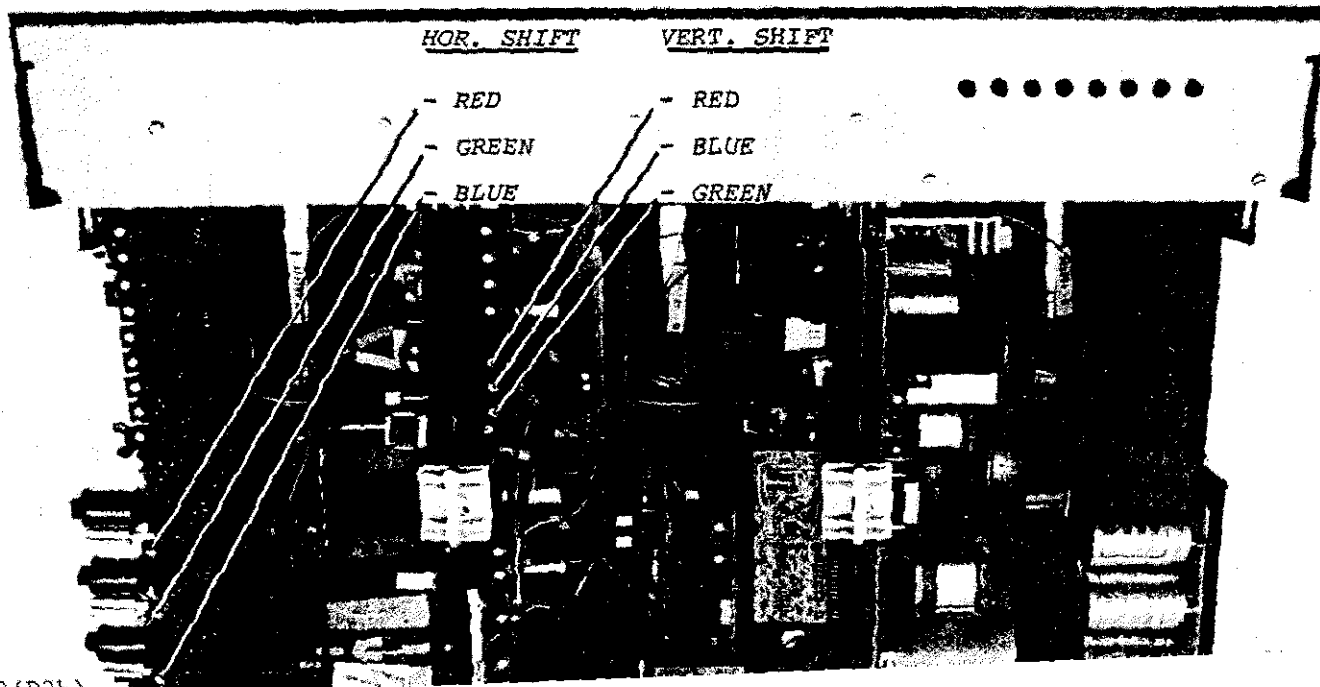

II. Dynamic convergence

The convergence control uses the split screen principle; by dividing the screen picture into 9 picture zones of equal size, each colour can be perfectly adjusted in each zone without adversely affecting convergence in any of the other zones.

Proceed as follow :

1. Vertical and horizontal convergence of the red and green picture.

- switch OFF the Blue picture (corresponding G2-switch in the OFF position).
- converge the Red picture on the Green picture in the following order :

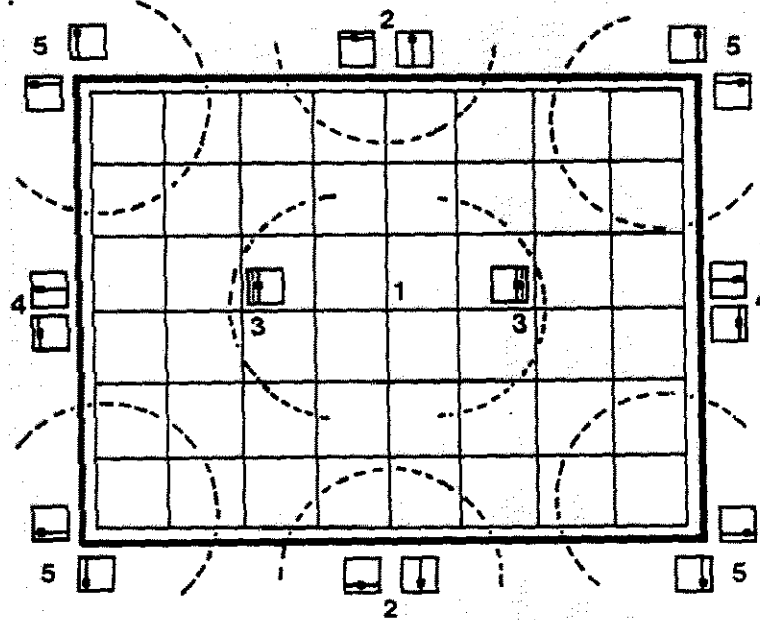

Important : Adjust the horizontal left and right convergence control for Red until correct convergence is obtained for the vertical lines on approx. 1/4 picture width distance from the outsides of the picture.

5 Corner convergence
Vert. Hor.
for RED

3 Vert & Hor
4 left & right
convergence
for RED

2 Vert & Hor
top & bottom
convergence
for RED

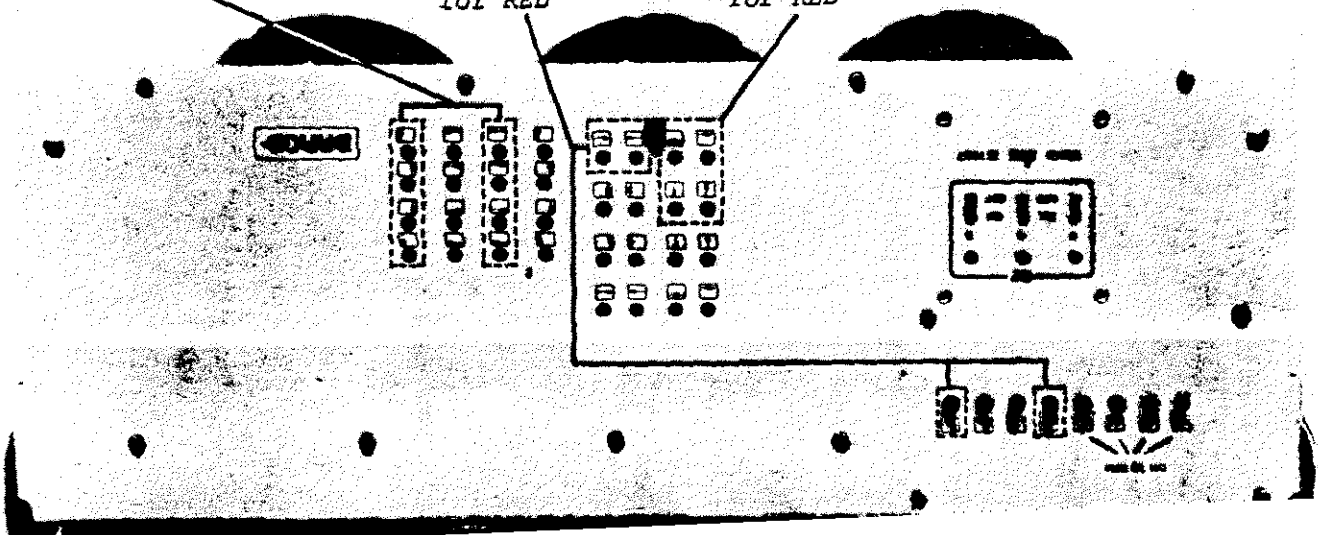

2. Vertical and horizontal convergence of the Blue and Green picture.

- switch OFF the Red picture (corresponding G2-switch in the OFF position).
- converge the Blue picture on the Green picture in the same manner as preceding, using the blue dynamic convergence controls.

Important : Adjust the horizontal left and right convergence control for Blue until correct convergence is obtained for the vertical lines on approx. 1/4 picture width distance from the outsides of the picture.

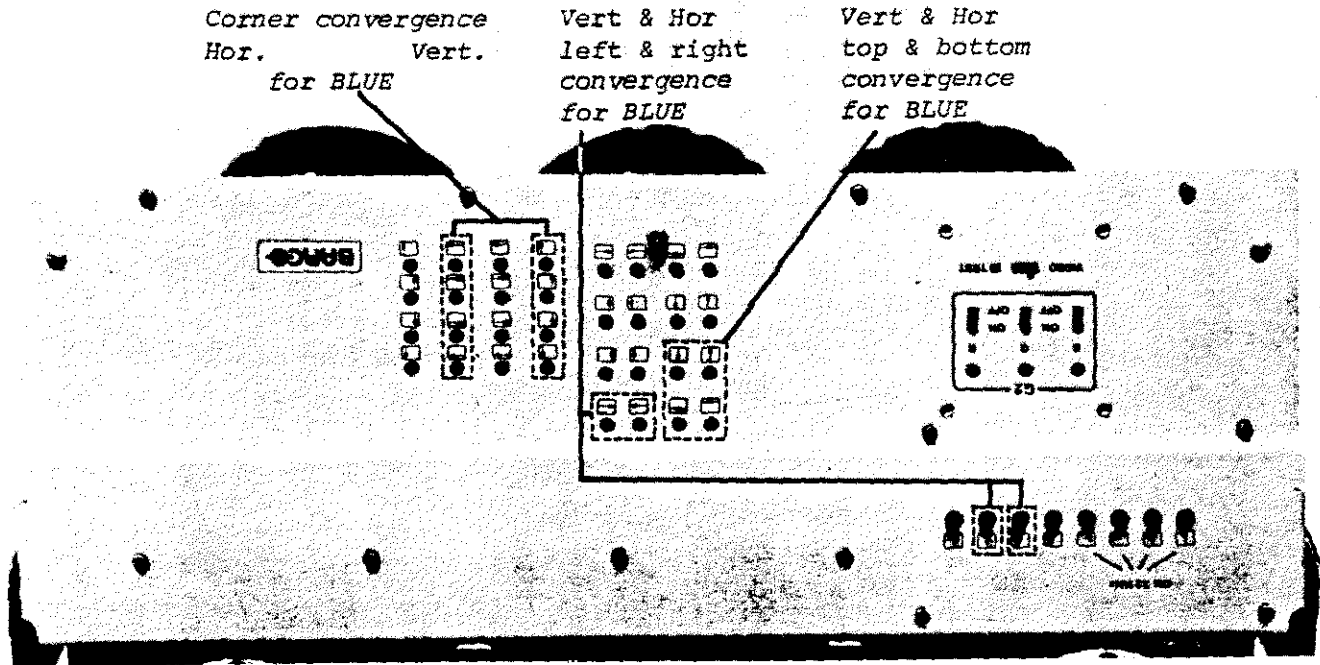

- switch ON the Red picture.

3. Additional convergence for the vertical lines of Red and Blue on the left and right outside of the picture.

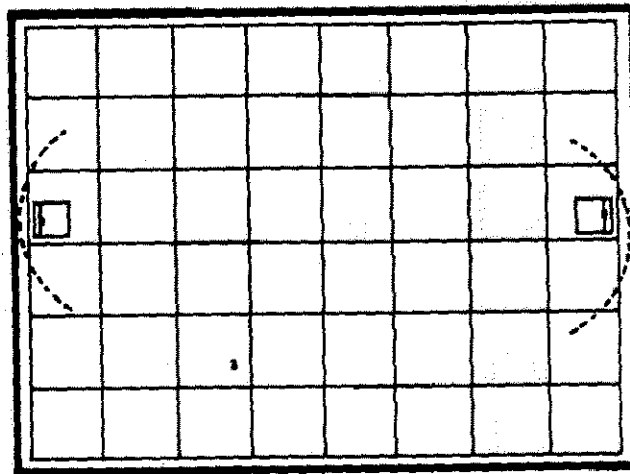

Converge the red and blue vertical lines on the left and right outside of the picture by means of the corresponding controls.

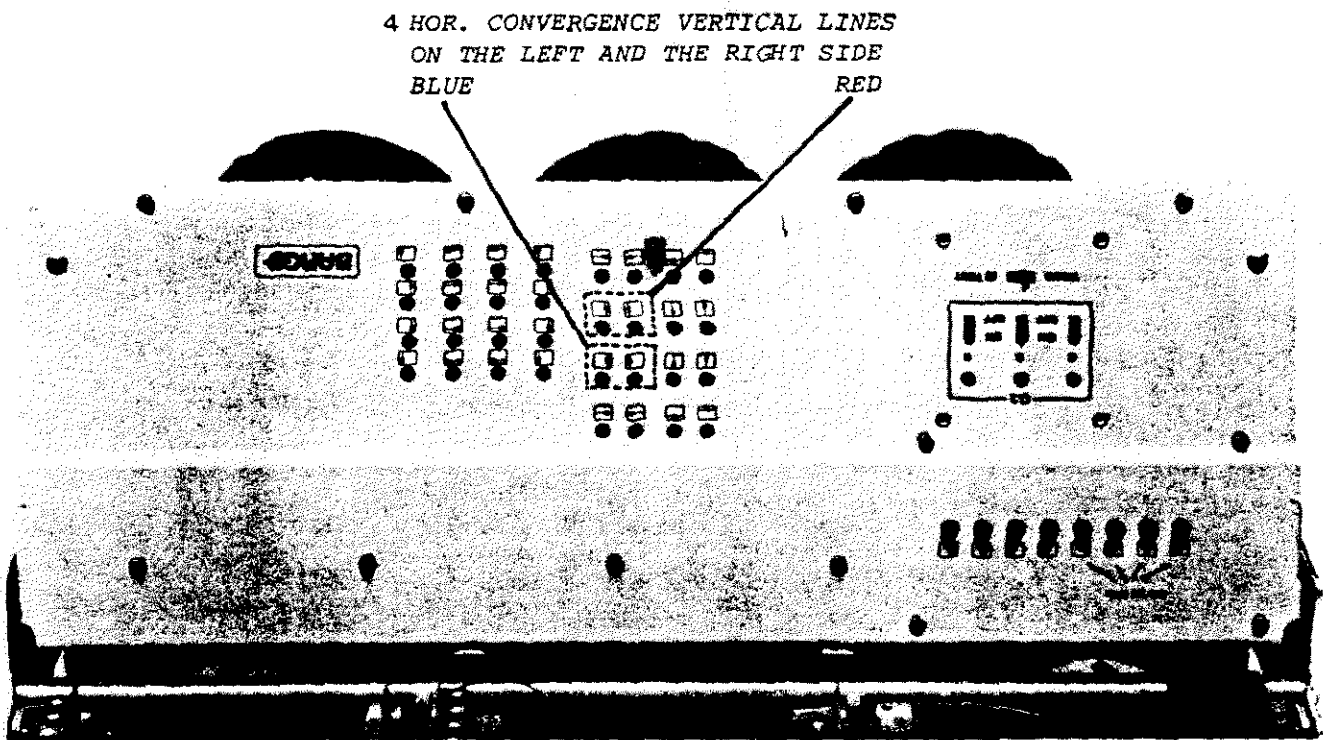

4. Additional convergence for Red and Blue when operating on high line frequency (switch Fstd/Fadj in the Fadj position).

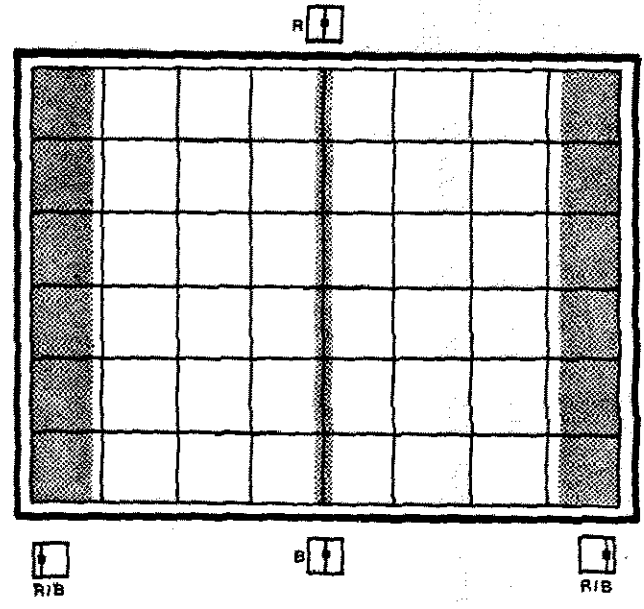

a) Hor. static control for Blue and Red

Adjust the Hor. static control for Blue and Red, so that respectively the red vertical and blue vertical center line converges with the green vertical center line.

b) Hor. dynamic control for Red/Blue at the most left and right side of the picture.

This convergence controls converge the Red/Blue vertical lines on this of green at the most left and right side of the picture.

ADDITIONAL RED-BLUE CONVERGENCE
WHEN OPERATING ON THE HIGHEST
LINE FREQUENCY (= 32 kHz)

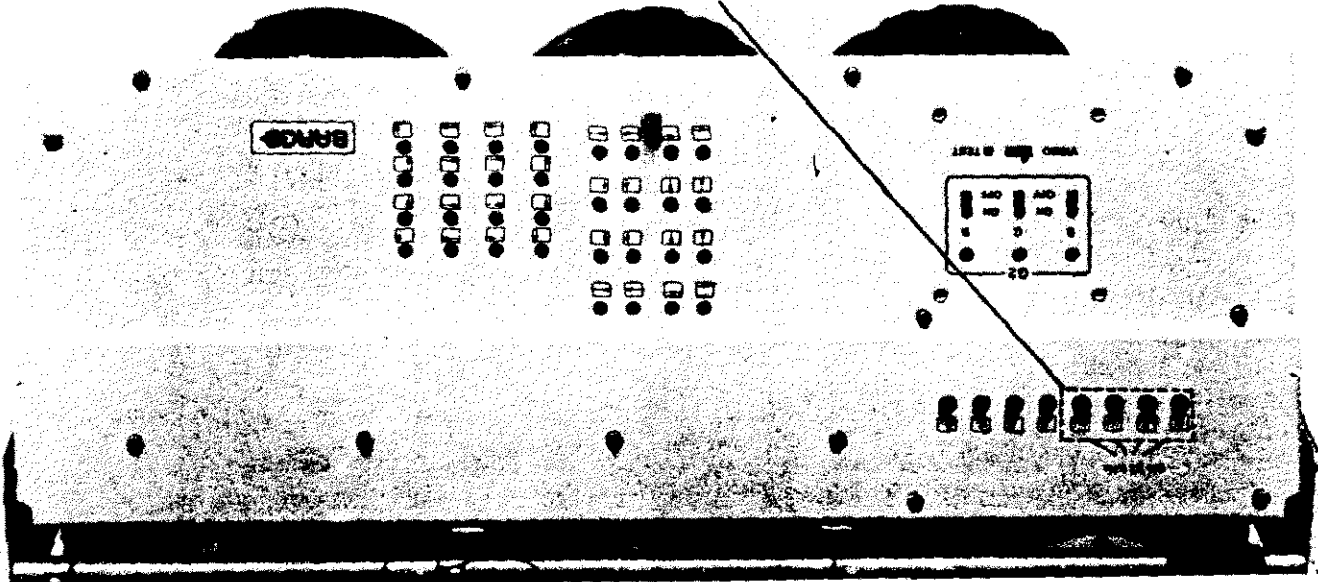

E. CUT-OFF ADJUSTMENT (GREY SCALE BALANCE)

- place the switch VIDEO/TEST in the position VIDEO.
- put in a standard colour bar test pattern signal to the video input of the projector, e.g. from a test pattern generator.
- place the brightness and contrast control in their mid-position.
- place the colour saturation control in its minimum position.
- switch OFF the blue and the red gun (G2-switches).
- adjust G2 green control until the response of the black bar is black.

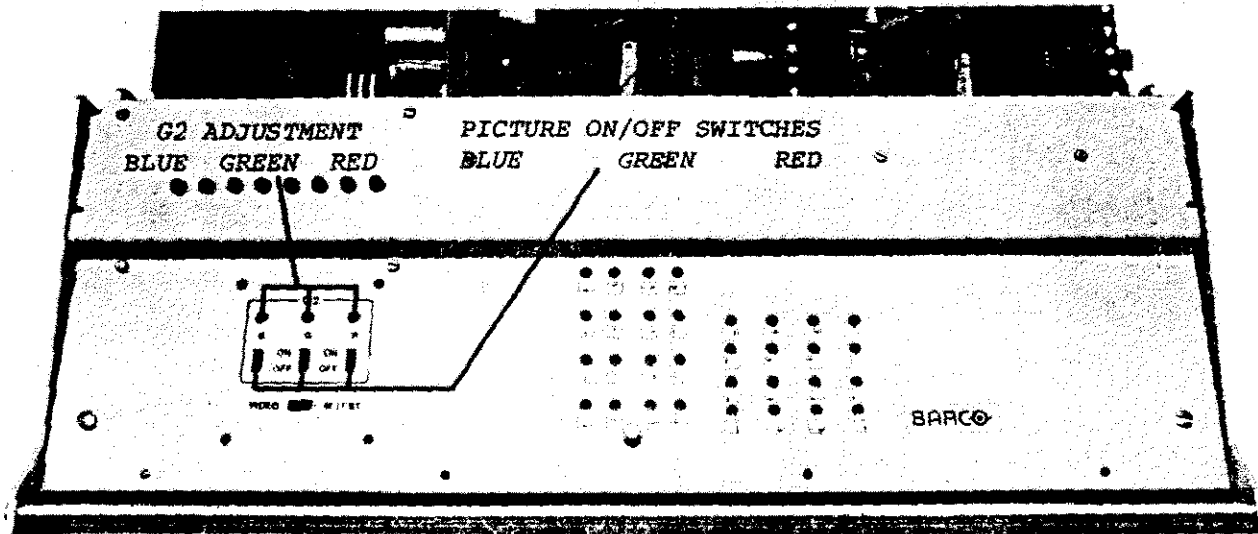

Important : The first green bar (A) must be distinguishable from the black bar.

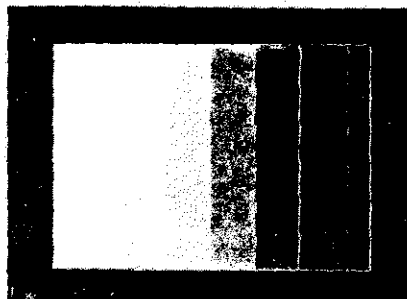

USE OF THE SECOND BUILT-IN CROSS-HATCH GENERATOR
IMPORTANT : ONLY USABLE IN THE RGB ANALOG AND RGB TTL MODE

On the VIDEO INPUT/CROSS-HATCH GENERATOR BOARD 76 12135 a second cross-hatch generator can be brought into operation by :

- moving the slide switch in the position (SYNC ON INPUT SIGNAL)
- changing the following connection (see fig.)

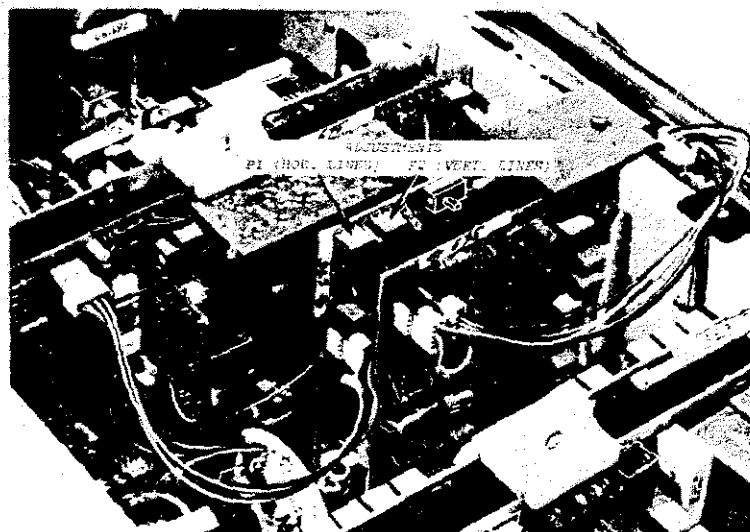
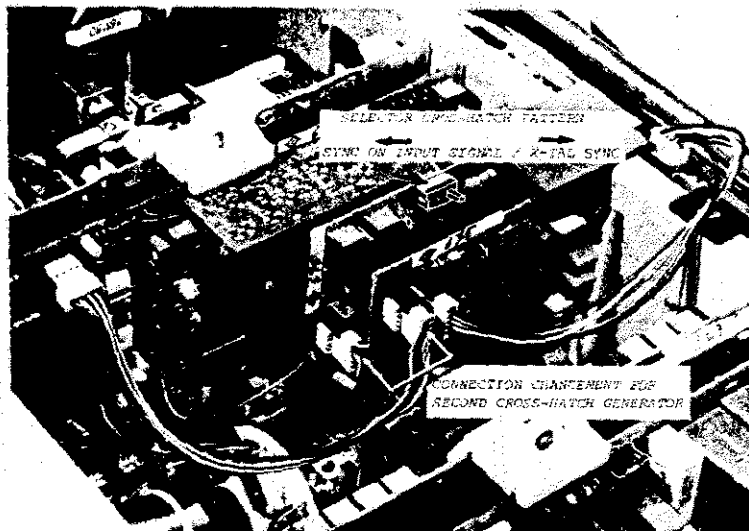

In this position a cross-hatch pattern will be displayed on the screen, SYNCHRONISED on the selected RGB Analog or RGB TTL input source.

Adjustments : Pot. P2 (VERT. LINES) : allows adjustment of the number of the lines.

Pot. P1 (HOR. LINES) : allows adjustment of the number of the lines.

VERY IMPORTANT : This generator can ONLY be used to adjust convergences and is not usable for picture geometry adjustments.