



# BARCOREALITY 912

## Digitally Controlled 12" CRT Projector

The BARCOREALITY 912 is the most powerful and versatile CRT projector available, through its unique 12" tubes and digitally controlled convergence and geometry. With 500 ANSI lumen, it more than doubles the conventional light output of most 'high-performance' CRT projectors available today. The BARCOREALITY 912 can handle the most severe geometric corrections for highly demanding applications such as simulation, VR planetaria, design centers, ultra-high performance graphics,...

### Very High Resolution Images

The BARCOREALITY 912 renders high resolution large screen images with unprecedented visual fidelity

- Available in compact standard housing, as well as in easy-access L-shape form
- Compatibility with workstations up to 3,200 by 2,560 pixels
- Horizontal autolock scan frequency range of 30-180 kHz
- 180 MHz RGB amplifier
- Ultra-high definition 12" electromagnetic focus CRTs with digitally controlled dynamic astigmatism guarantee razor sharp images
- TSN™ 6-pole focus astigmatism correction

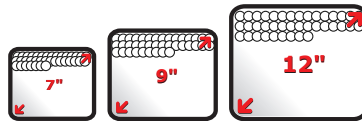

*The 12" CRT tubes offer a phosphor area nearly twice as large as the 9" tubes. As adjacent pixels have less overlapping, this results in the highest projection performance, both in resolution and light output, ever achieved by CRT projectors.*

### Unequaled Flexibility

- Mosaic geometry correction: Flat, Curved, Off axis
- Digital image correction optimized for curved screens and multi-channel setups
- Different lenses are available, optimized for screens with sizes ranging from 2,0 m (6.6 ft.) to 10 m (32.8 ft.) wide, including curved screens
- Built-in Scheimpflug optical correction, with stepless adjustment, for optimal optical focus for off-axis projection
- Optional Digital AutoImage™ automatic alignment system aligns all geometry and convergence parameters
- Optional 3D & Stereoscopic optimized phosphors

# Features and Specifications

## Light Output

ANSI lumen:  
 Economy Mode: 350 lumens  
 Normal Mode: 410 lumens  
 Boost Mode: 500 lumens

## CRTs

High brightness, ultra-high definition liquid cooled 12" electromagnetic focus CRTs

## Lenses

Ultra-high definition, fully color corrected, liquid cooled lenses

## Screen sizes

Min.: 2.0 m x 1.8 m (6.6' x 5.9')  
 Max.: 10 m x 7.5 m (32.8' x 24.6')

## Scan Frequencies

Horizontal: 30 - 180 kHz autolock  
 Vertical: 37 - 240 Hz autolock

## Minimal Retrace Time

Horizontal:  
 < 1.1  $\mu$ s in range 90-180 kHz  
 < 1.8  $\mu$ s in range 30-130 kHz  
 (switching point adjustable between 90 and 130 kHz)  
 Vertical: < 200  $\mu$ s

## RGB Bandwidth

180 MHz [-3 dB]

## Horizontal Linearity

<  $\pm 0.25$  % distortion @ 1280 x 1024 (60Hz) with convergence on green option  
 <  $\pm 1.5$  % distortion throughout the full horizontal frequency range

## Inputs

- RGB or (Y, R-Y, B-Y) input on 5 BNC-connectors, with automatic sync detection and sync polarity, with sync on green or separate sync

- RGB analog input on D9-connector, with automatic sync detection and polarity (optional D9-BNC adapter available)
- Optional Video (PAL, SECAM, NTSC 3.58, NTSC 4.43), loop-through (2xBNC) with 75 Ohm termination switch (requires LiMo Pro option)
- Optional S-Video input (4-pin mini-DIN), loop through with 75 Ohm termination switch (requires LiMo Pro)

## Special Features

- CRT drive in 3 modes: normal mode, economy mode for longer lifetime of the CRTs, and boost mode for special applications
- 48 frequency-related memory banks
- Color temperature adjustment (3200K, 4900 K, 6500K, 9300K or custom)
- A built-in Scheimpflug optical correction, with stepless adjustments for both horizontal and vertical axis
- Optional fast green CRT for stereoscopic projection

## Power Consumption

1,100 W

## Safety regulations

The BARCOREALITY 912 complies with UL1950 and EN60950

## Electromagnetic interference

The BARCOREALITY 912 complies with and CE EN55022 Class B

## Weight

150 kg (330,7 lbs)

## Order information

BARCOREALITY 912 R9040020  
 230 V  
 LiMo Pro R9828631  
 Executive remote control R9829960

## Communication cables

- 5 m (16 ft.) R9827770
- 15 m (50 ft.) R9827560
- 30 m (100 ft.) R9827570

## Ceiling Mount 808/1200

- with Pulley System R9827341
- without Pulley System R9827342

## Dimensions mm inch

### • Standard

W	930	36.6
W1	563	22.2
L	738	29.0
L1	527	20.8
H	703	27.7
H1	400	15.7

### • L-Shape

W	930	36.6
W1	563	22.2
L	1037	40.8
L1	629	24.8
H	525	20.7
H1	400	15.7

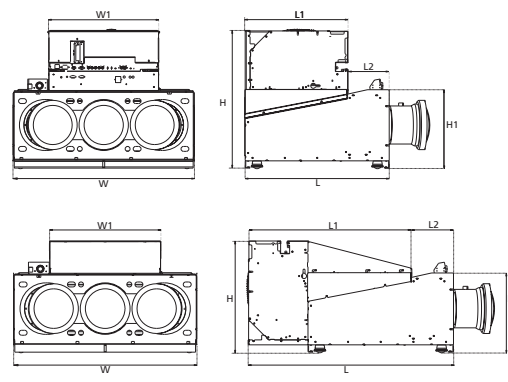

## Barco Simulation Products

a business unit of Barco Projection Systems

### in Europe

Noordlaan 5, 8520 Kuurne, Belgium  
 Phone +32 56 36 82 11 Fax +32 56 36 84 86  
 E-mail: sales.bps.bsp@barco.com

### in US

600 Bellbrook Ave.  
 Xenia, OH 45385  
 Phone +1 (937) 372 7579 • Fax +1 (937) 372 8645  
 E-mail: eis@barco.com

www.barco.com

**BARCO**



BARCO Projection Systems is an ISO 9001 registered company.

The information and data given are typical for the equipment described. However any individual item is subject to change without any notice.

Ref. n°: R59595 - October 2001 - Printed in Belgium