

RETRODATA 808s

High Contrast, Rear Screen Projection System

BARCO's RetroData 808s projector is a high performance, stand-alone rear screen projection system, capable of displaying video and data images with outstanding light output, rich contrast and exceptional clarity, even under high ambient lighting conditions. The RetroData 808s is ideally suited for a wide range of presentation and training applications including multimedia events, trade shows, training seminars, educational centers and boardroom meetings,...

Outstanding Image Quality

Based on an advanced optical concept, the RetroData 808s offers razor sharp and crystal clear images, even under high ambient light conditions.

- High-definition 8" CRTs with electromagnetic focus system
- Single front surface-coated optical grade mirror
- F1.1 color corrected hybrid liquid coupled lenses
- 67" Fresnel/Lenticular-Blackstripe screen with very wide horizontal and vertical viewing angles
- Built-in IRIS³ automatic alignment system aligns on-screen convergence and geometry in less than 2.5 minutes
- Optional built-in Video Line Doubler improves Video image quality

Broad Compatibility

The RetroData 808s is compatible with a wide range of PC graphics boards with a resolution up to 1,280x1,024 pixels/70Hz

- Horizontal autolock scan frequency of 15-75 kHz
- Vertical scan frequency of 37-200 Hz
- RGB bandwidth of 75 MHz
- Universal connection possibilities



New!

Now with Built-in
IRIS³ Auto-Convergence
and Auto-Geometry

BARCO

High Brightness, High Contrast Rear Screen Video and Data Projection System

State-of-the-art Optical System
The RetroData 808s incorporates three high-definition 8" CRTs with an electromagnetic focus system, F1.1 color corrected hybrid lenses and a single front surface-coated mirror. This results in the projection of ultra-sharp images with extremely high light output.

A proprietary Fresnel / Lenticular-Blackstripe screen with a fine pitch of 0.62 mm offers not only a very wide horizontal and vertical viewing angle, but also crystal clear images, even under high ambient light conditions.

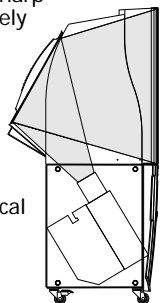

Easy Set-up and Control
The RetroData 808s is based on BARCO's advanced digital architecture which provides user-friendly remote control of all set-up and display functions. Extremely precise, yet simple adjustments are accomplished through intuitive, on-screen menu-driven displays.

Built-in Audio Capabilities
The RetroData 808s is equipped with a high fidelity stereo audio amplifier (2x15 W) and two frontal 2-way speaker systems (20 W). This eliminates the need of external audio equipment for the playback of video and RGB signals with audio.

Easily Transportable Cabinet
The RetroData 808s has a lightweight, easily transportable cabinet with a retractable mirror assembly which fits through any standard door opening.



A convenient snap lock system firmly locks the retractable mirror into position.

Highly Flexible Mechanical Design

Operating position

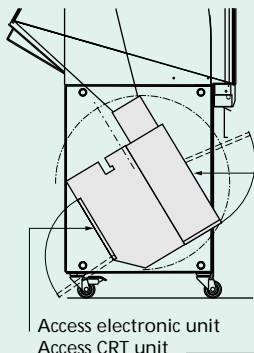

Service position 1

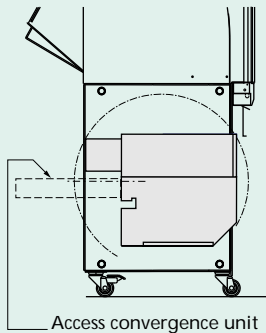

Service position 2

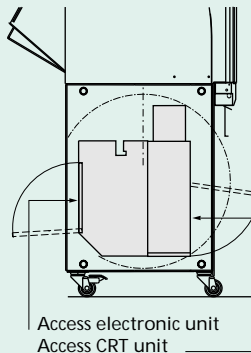

Service position 3

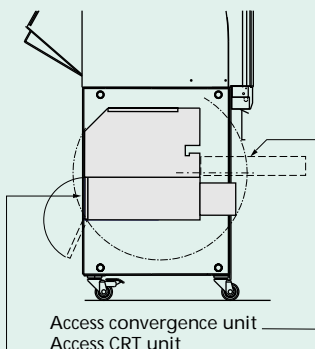

Service position 4

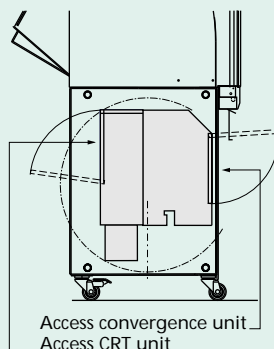

The RetroData 808s is based on an innovative mechanical concept. The projector chassis can be easily rotated in order to get full access from the front or the rear side of the projector, which facilitates installation and maintenance of the projector.

Technical specifications

Luminance

At 10% peak white:

1,250 Nit / 364 ftL.

ANSI:

Economy mode: 139 Nit / 41 ftL.

Normal mode: 195 Nit / 57 ftL.

Boost mode: 214 Nit / 62 ftL.

CRTs

High brightness, high definition, liquid cooled 8" electromagnetic focus CRTs

Lenses

High definition, fully color corrected, liquid coupled F1.1 hybrid lenses

Optical Resolution

10 lp/mm at 50% MTF throughout the field

Projection Screen

- Size (diagonal): 67" / 1.7 m

- Type: Fresnel/Lenticular Blackstripe

- Pitch: 0.62 mm

- Viewing angle (50% brightness)

Horizontal: $\pm 42^\circ$

Vertical: $\pm 13^\circ$

Scan Frequencies

Horizontal: 15 - 75 kHz autolock

Vertical: 37 - 200 Hz autolock

Minimal Retrace Time

Horizontal: $< 2.5 \mu\text{s}$

Vertical: $< 300 \mu\text{s}$

Horizontal Linearity

$< \pm 1.5\%$ distortion in the full horizontal frequency range

RGB Bandwidth

75 MHz [-3 dB]

Inputs

- RGB or Component (R-Y, B-Y, Y) input on 5 BNC-connectors, sync on green or separate sync, automatic sync polarity, composite sync or H/V sync
- RGB analog input on D9-connector with automatic sync detection and sync polarity (optional D9-BNC adapter available)
- Video (PAL, SECAM, NTSC 4.43, NTSC 3.58), loop-through (2xBNC) with 75 Ohm termination switch
- S-Video input (4-pin mini-DIN), loop-through with 75 Ohm termination switch (can also be programmed as a second Video input)

Special Features

- Built-in IRIS³ Auto-Convergence and Auto-Geometry alignment system

- CRT drive in 3 modes: normal mode, economy mode for longer lifetime of the CRTs, and boost mode for special applications

- Multi-language on-screen menus: English, French, German and Spanish

- 32 frequency-related memory banks

- L.D.I. (Linear Digital Interpolation)

- Intuitive on-screen display: installation and service screens, barscale display of user settings, on-screen display of selected source

- Automatic storing of all adjustments

- Ability to set parameters to midposition

- Colour temperature adjustment (3200 K, 4900 K, 6500 K, 9300 K or custom)

- RS232 control

- Easily transportable cabinet with retractable mirror, fits through any standard door opening

- Lightweight design

- The special mechanical design of the projector chassis makes it possible to rotate the chassis in order to get full access from the front or the rear of the projector, which facilitates installation and maintenance

- Removable screen profiles allow the unit to be used in a side-by-side configuration with adjacent screen gap of less than 1.25" (30 mm)

- Standard Windows Control Software included

Operator Controls

All controls are accessible through a soft-touch panel or a user-friendly backlit infrared remote control.

- Source switching

- User settings per source: sharpness, tint, colour, brightness, contrast and audio controls (volume, bass, treble, balance)

- Geometry per source (password protectable)

- Convergence per source (password protectable)

- An optional Executive Remote Control unit is available for control of source switching and limited adjustment of user settings

Audio

- Built-in stereo audio amplifier (2x15 W continuous sine wave), with 2 frontal 2-way speaker systems (2x20 W)

- Stereo audio input on 2 Cinch (RCA phono) connectors

- 2 audio DIN connectors for external loudspeakers

- Audio follows Video switching

Safety Regulations

The RetroData 808s complies with UL1950 and EN60950.

Electromagnetic Interference

The RetroData 808s complies with FCC part 15 Class B (120 V version) and CE EN55022 Class B (230 V version).

Radiation Regulations

The RetroData 808s complies with DHHS radiation emission standards 21 CFR Subchapter J.

Weight

Net weight : 331 lbs. / 150 kg

Shipping weight: 474 lbs. / 215 kg

Power Consumption

550 Watts. (nominal)

Thermal Dissipation

Max. 1875 BTUs/hour

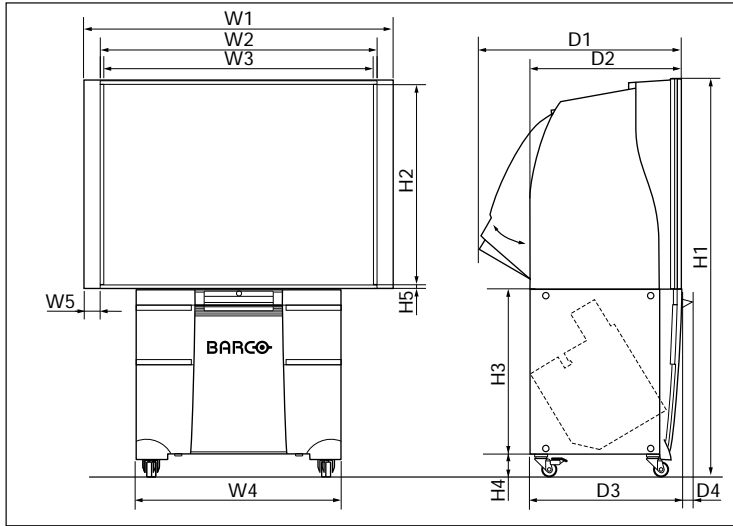

Dimensions	mm	inch
W1	1,535	60.42
W2	1,370	54.03
W3	1,341	52.81
W4	1,020	40.10
W5 ⁽¹⁾	82	3.23
D1	996	39.21
D2	747	29.43
D3	743	29.25
D4	70	2.74
H1	1,969	77.53
H2	997	39.25
H3	820	32.27
H4	110	4.35
H5	22	0.85

Shipping Dimensions	mm	inch
Top		
W	1,530	60.24
D	910	35.83
H	1,310	51.57
Bottom		
W	1,150	45.28
D	870	34.25
H	1,180	46.46

Order information

RetroData 808s

230 V: R9002111
120 V: R9002118

RCVDS 05 source selector

230 V: R9827880
120 V: R9827889

LiDo Line Doubler Kit R9828161

Projector Control Software

Advanced Version R9828690

Communication cables

- 5 m / 16 ft. R9827770
- 15 m / 50 ft. R9827560
- 30 m / 100 ft. R9827570

Executive remote control

R9827970

ACTAS Automatic Colour

Temperature Alignment System

230 V: R9827961
120 V: R9827968

Remote infrared receiver

R9827515

D9-BNC cable adapter R9827840

Tri-level sync input R9828040

Special add-in boards:
- Contrast modulation kit R9828145

- Orbiting kit R9827781

(1) Side profiles are removable.



BARCO Projection Systems is an ISO 9001 registered company.

The information and data given are typical for the equipment described. However any individual item is subject to change without any notice.

BARCO Projection Systems - Head Office
Noordlaan 5 8520 Kuurne, Belgium
Tel: +32 / 56 / 368 211 Fax: +32 / 56 / 351 651
E-mail: sales.bps@barco.com
Visit our Website: <http://www.barco.com>



Ref. n°: R599437-01 March '99 - Printed in Belgium