

---

# Technical Bulletin

---

## Deadline for Heater Voltage Test

Please review the attached *Technical Bulletin TB98-06* from last November.

The deadline for completing your *Marquee* heater voltage testing and returning the *Heater Voltage Form* to Christie Digital Systems is **February 29, 2000**. After this date, we will no longer offer a replacement LVPS for those projectors having a heater voltage that falls outside of the accepted range as described in TB98-06.

---

# Technical Bulletin

---

## Testing and Replacing the *MARQUEE* Low Voltage Power Supply (LVPS) to Ensure Optimal Performance

**This bulletin includes the following:**

- How to test heater voltage in the *MARQUEE* Low Voltage Power Supply (LVPS)
- How to replace a *MARQUEE* Low Voltage Power Supply (LVPS)

*Applies to Low Voltage Power Supply (LVPS)  
Part number 10-000229-02P used in  
Marquee 8110, 8500, 8500LC, 8500SM, 9500LC, 9500DM, 9500HS series projectors  
manufactured between August 1<sup>st</sup> 1996 and August 31<sup>st</sup> 1998.*

*Also applies to service modules #03-000229-02P or #03-000229R02P.*

*NOTE: Does **not** apply to any LVPS produced after August 31, 1998. Does **not** apply to the Marquee Ultra series projectors.*

---

### ● **Background**

We have discovered that a small percentage of Low Voltage Power Supplies (LVPS) as far back as August of 1996 may have an incorrect heater voltage. This could interfere with optimal performance. We recommend that you perform the heater voltage test described in this Technical Bulletin as part of regularly scheduled maintenance. If you find that the LVPS heater voltage measurement falls outside of the specified range of 5.7-6.6 volts, Electrohome will provide a replacement LVPS.

### ● **Actions Required**

1. **USE THE DATE CODE TO DETERMINE IF YOUR PROJECTOR REQUIRES TESTING:** A date code is stamped in ink on the projector box near one of the serial number/bar code labels. The date may also appear on the front of the projector. If two different date codes appear, the most recent one applies.

---

# Technical Bulletin

---

Projectors dated *after August 31<sup>st</sup> 1998* have the new LVPS and require no corrective action.

*Note: The format of the date code is Year-Month-Day-Hour. For example, August 31<sup>st</sup> 1998 is **8H31B**, where **8** represents 1998, **H** represents August (**A** would be January, **B** would be February etc.), **31** represents the day of the month and the **B** indicates the hour.*

2. For the projectors listed at the beginning of this bulletin (or if you cannot determine the date of your projector), check the LVPS part number labeled on the front of the LVPS — see Steps 10a-10c later in this document for instructions on how to access the LVPS. If the LVPS is labeled "10-000229-02P", test the LVPS heater voltage as described in this bulletin.
3. Follow the *How to Test Heater Voltage* instructions below. Replace the LVPS if it has a heater voltage measuring **below 5.7 volts** or **above 6.6 volts**. Request an RMA and return the old LVPS to your nearest Electrohome service depot.
4. For each LVPS tested (whether its heater voltage is within the specified range or not), complete the attached form and return it to your nearest Electrohome service depot.

## ● **Equipment Needed for This Procedure**

- Phillips screwdriver
- A calibrated digital voltmeter with extremely fine-pointed probe tips. Make sure the batteries are full power and that the meter measures voltage to 2 decimal places.
- You may wish to order a new Low Voltage Power Supply (part #03-000229-03P or #03-000229R03P) to have on hand for this test. Should you detect a high heater voltage on your old LVPS and have to replace it, return it to Electrohome for credit. If the heater voltage is within the specified range, you can either keep the new LVPS or return it to Electrohome for credit — there will be no restocking fee.

---

## **WARNINGS**

---

# Technical Bulletin

---



⚠ This test requires handling of electronic components and must be performed by qualified service personnel only. **Read all instructions before you begin.**

⚠ Always observe proper Electrostatic Discharge (ESD) precautions. If you are uncomfortable with performing this test, it can be done for you at an authorized Electrohome service depot.

## ● How to Test the LVPS

- 1) Power up the projector (press <power> on built-in or IR remote keypad and hold for 1 second). The green LED on the back of the projector should then be on.
- 2) Record the *Hours of Use* on the form provided. *Hours of Use* information is shown in the *Hours Of Use* menu under *Diagnostics* in the *Service* menu available from the *Utilities* menu. Press <UTIL> <9> <password 0-9-0-1> <6> <3>. Press <exit> when done.
- 3) Record the serial number and model of the projector. Both are displayed on the first *Status Page* — press the <\*> key to access it.
- 4) Turn off the projector.
- 5) Remove the rear top cover of the projector (see Figure 1).

a) Loosen 2 fixing screws.

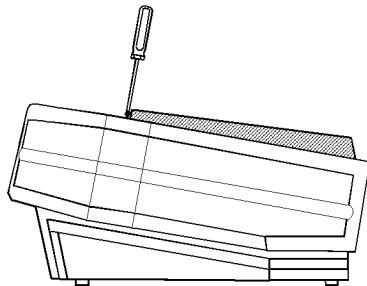

b) Slide rear cover back.

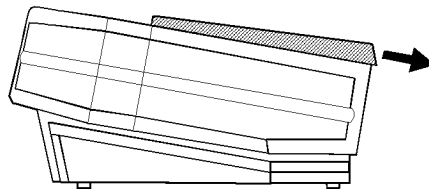

**Figure 1. Remove the Top Rear Cover**

---

# Technical Bulletin

---

- 6) Remove the projector rear panel (see Figure 2). If the projector is ceiling mounted, take care that all modules are secured and out of the way.

*NOTE: 3 of the top 4 screws all have ground braids attached. You will have to re-connect properly.*

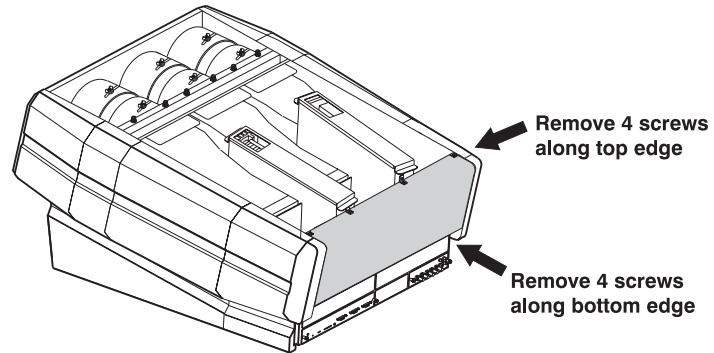
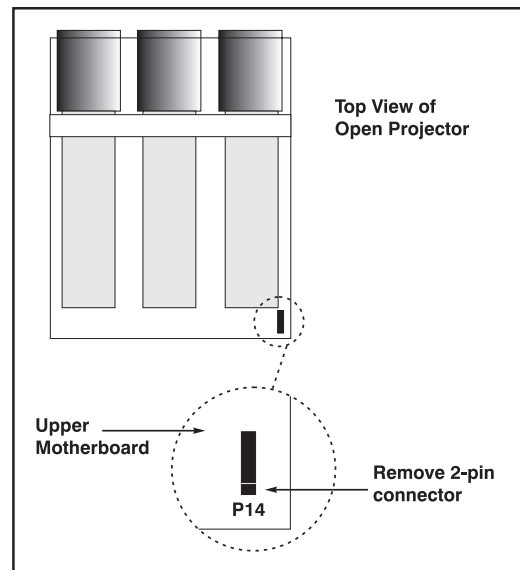

**Figure 2. Remove Rear Panel**

## WARNING

**Do not let the ground braids touch any circuitry!**

- 7) Disconnect the harness from the Upper Mother Board at the P14 connector (2-pin). This harness runs back to the LVPS, which supplies the heater voltage. See Figure 3.
- 8) Turn the projector back on (press <power>). The LED should be green.
- 9) Make sure P14 is disconnected. Measure the heater voltage across pins 1 and 2 in the P14 connector. Record this value on the form provided.



**Figure 3. UMB Connector at P14**



## WARNING

**High voltages are present in the projector.  
Use extreme caution.**

- If the voltage measures anywhere from **5.7 volts** to **6.6. volts**, no further work is required in the projector — reconnect P14 and close up the projector. Skip to step 12.

---

# Technical Bulletin

---

- If the voltage measures **above 6.6 volts** or **below 5.7 volts** , the LVPS must be replaced and returned to Electrohome. Reconnect P14, close up the projector and power it down. Go to Step 10.

**10)REPLACING THE LVPS:** If your LVPS has a heater voltage **above 6.6 volts** or **below 5.7 volts**, replace it with LVPS part #03-000229-03P or #03-000229R03P (or higher). *NOTE: Once you have installed either #03-000229-03P or #03-000229R03P or higher, you will no longer need to check heater voltage as part of regularly scheduled maintenance.*

**⚠ WARNING ⚠**

**Do not try to repair or open the LVPS.  
This component is non-serviceable.**

**⚠ WARNING ⚠**

**Unplug the projector before proceeding.**

- a) Unplug the projector.
  - b) Remove the 2 front screws at the bottom of the projector front panel.
  - c) Remove the 2 screws along the panel sides. Pull the panel down.
  - d) Unscrew the 2 screws from the top of the Low Voltage Power Supply.
  - e) Grasp the handle of the LVPS and pull the component out of the projector.
  - f) Install the new LVPS, replacing all screws removed in steps b) through d).
  - g) Check that you have reconnected the P14 connector. Close up the projector, making sure to reconnect all ground braids and secure all screws.
  - h) Check that the projector powers up properly. If not, recheck the above steps.
- 11)**Request an RMA and return the old LVPS to your nearest Electrohome Service Depot.
- 12)**Complete the heater voltage form and send it to your nearest Electrohome Service Depot.

# Technical Bulletin

## HEATER VOLTAGE FORM

This form must be completed and returned to  
your nearest Electrohome Service Depot.  
Photocopy as necessary for each projector tested.

**Serial #:** \_\_\_\_\_

*(see projector Status Page 1)*

**Model:** \_\_\_\_\_

**Date of Installation:** \_\_\_\_\_

*(if known)*

**Hours of Use:**

*(In menus, go to*

*<Utilities><9><Password 0901><6><3>)*

**CRTs On:** \_\_\_\_\_

**In Standby:** \_\_\_\_\_

**Heater Voltage:** \_\_\_\_\_

**Date of Test:** \_\_\_\_\_

**My Name:** \_\_\_\_\_

**Dealer Name:** \_\_\_\_\_

**Address:** \_\_\_\_\_

\_\_\_\_\_

\_\_\_\_\_

**Site Location:** \_\_\_\_\_

**Please send a MARQUEE  
Low Voltage Power Supply  
Part #03-000229-03P or 03-000229R03P  
(CALL FOR PRICE)**