

**ELECTRONIC  
SYSTEMS  
PRODUCTS..**

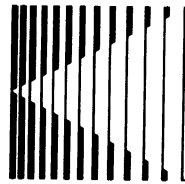

***ESPRIT***

**MODELS 300/500/535  
PRELIMINARY  
SERVICE MANUAL**

# ESPRIT 300/500/535

## PRELIMINARY SERVICE MANUAL

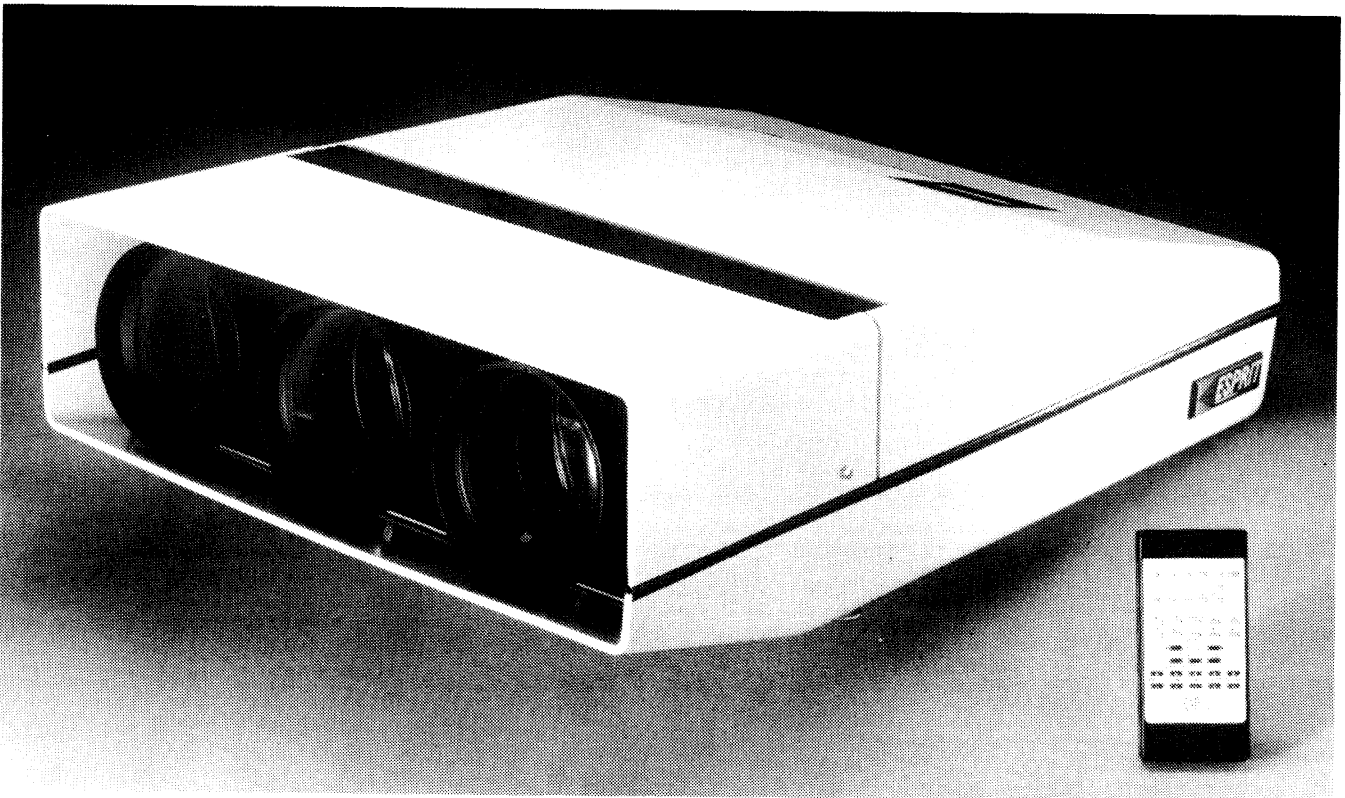

INTERCONNECT WAVEFORMS AND VOLTAGES

PRELIMINARY SERVICE MANUAL

TABLE OF CONTENTS

	<u>Page</u>
Using our Technical Assistance Line .....	1
Procedure for Warranty Exchange of Esprit Sub-Assemblies .....	2
NTSC Standard Wave Form .....	3
Esprit Model Case Work Dimension with Ceiling/Floor Mount Location .....	4
300/500/535 Control Locations Guide .....	5
300/500/535 Esprit Interconnect .....	6
Quad Standard Video Decoder (80582) .....	8
Interconnect Waveforms/Voltages Quad Standard Video Decoder .....	10
Comb Filter Rev. X (80583) .....	11
Comb Filter Rev. B .....	12
300/500 RGB BD (80674) .....	13
Interconnect Waveforms/Voltages RGB Module .....	15
500-1000 TTL Board (80687) .....	17
Interconnect Waveforms/Voltages TTL Module .....	18
535 CRT BD (80684) .....	19
300 Horizontal Deflection Rev. X (80621) .....	20
300 Horizontal Deflection Rev. C .....	22
500 Horizontal Deflection Rev. X (80577) .....	24
500 Horizontal Deflection Rev. B .....	26
535 Horizontal Deflection (80682) .....	28
Interconnect Waveforms/Voltages Horizontal Deflection Module .....	30
300/500 H.O.T. BD (80664/80665) .....	32
535 H.O.T. BD Rev. C (80683) .....	33
535 H.O.T. BD Rev. B .....	34
Interconnect Waveforms/Voltages H.O.T. Module .....	35
300/500/535 Vert Sweep Bd Rev. F (80685) .....	36
300/500/535 Vert Sweep Bd Rev. C .....	38
Interconnect Waveforms/Voltages Vertical Deflection Module .....	40
300/500/535 SMPS (80675) .....	41
SMPS Filter Bd (80694) .....	42
Interconnect Waveforms/Voltages SMPS Module .....	43
300/500/535 H.V.P.S. (80649) .....	44
Focus Modulator Bd (80679) .....	45

TABLE OF CONTENTS (continued)

	<u>Page</u>
Registration Bd (A80587) .....	46
300/500 Registration Amps (80645) .....	53
535 Registration Amps (80586) .....	54
Hardwired Remote Control (69053) .....	55
6809 CPU Board (80653) .....	56



## USING OUR TECHNICAL ASSISTANCE LINE

ESP provides technical assistance by telephone for in- and out-of-warranty products. We offer the time and attention of one or more technical specialists to help you with your repairs, modifications, installations, computer interfacing and any special problems you may encounter with the Aquaray, Aquastar or Esprit product lines.

### BE PREPARED

You may be able to avoid a call altogether by using the information in the supplements, field bulletins and installation/set-up manuals provided to you as dealers. However, if you still need help, please assemble the following information prior to placing your call.

Serial number of the projector

Date of manufacture

Model number

Dealer and/or customer name and installation parameters

- \* Have a complete record and clear understanding of the symptoms (see your owner or installation/set-up manual).
- \* Verify the basic operation of the product.

Diagnostic LED's

LED number codes

LCD message readouts

- \* Use an oscilloscope or DVM, or refer the problem to someone for an evaluation who has such diagnostic experience.
- \* Have the service information and schematics in front of you when you call.

This initial troubleshooting will best utilize technical personnel, avoid excessive telephone charges, and expedite your repairs.

### PERSONNEL TO TALK TO IN THE SERVICE DEPARTMENT

Ext. 40	Rich Manning	-- Service policies & procedures, tech questions
Ext. 58	Mike O'Berry	-- Technical questions, all products
Ext. 32/27	Glenn Caswell	-- 700/1000 Systems Specialist, tech questions
Ext. 41/58	Pat Irving	-- In house unit, board repair status
Ext. 34	Judy Myers	-- Order processing & shipment of repair parts. Unit returns, return authorizations, board & part exchanges, warranty claims.

Phone: 1-800-327-3644  
 (407) 269-6680  
 Fax: (407) 267-6211

ELECTRONIC SYSTEMS PRODUCTS  
 RICHARD MANNING  
 MANAGER, TECHNICAL SERVICES



1301 Armstrong Drive  
Titusville, FL 32760-7000 USA  
(407) 267-6800  
Fax (407) 267-6211

## ELECTRONIC SYSTEMS PRODUCTS

---

### PROCEDURE FOR WARRANTY EXCHANGE OF ESPRIT SUBASSEMBLIES

#### INFORMATION REQUIRED BY ESP AT TIME OF REQUEST FOR A WARRANTY EXCHANGE:

1. Serial number and model number of product.
2. Serial number and part number of subassembly.
3. Purchase order number.

A return authorization must be obtained prior to the return of a subassembly.

#### METHOD OF SHIPMENT:

Shipping charges to the manufacturer are to be prepaid by the customer.

Shipping charges from the manufacturer via UPS surface will be prepaid by ESP.

#### RETURN OF DEFECTIVE SUBASSEMBLY:

Manufacturer will ship a replacement subassembly prior to the return of defective subassembly. However, the defective subassembly must be received within ten (10) working days thereafter or the shipment will be invoiced at the price of a new subassembly.

#### WARRANTY PERIOD:

Completed Certificate of Registration must be postmarked within thirty days from date of installation; otherwise manufacturer will consider the date of warranty to begin at time of shipment from the factory.

#### WARRANTY:

The Esprit limited warranty per Chapter 3.0 of the Owner/user Manual will be voided if the subassembly is repaired and/or modified by anyone other than ESP factory personnel.

Technical Service Department

NTSC STANDARD WAVE FORM

SCOPE ADJUSTMENT OF LUMINANCE , CHROMA AND SETUP

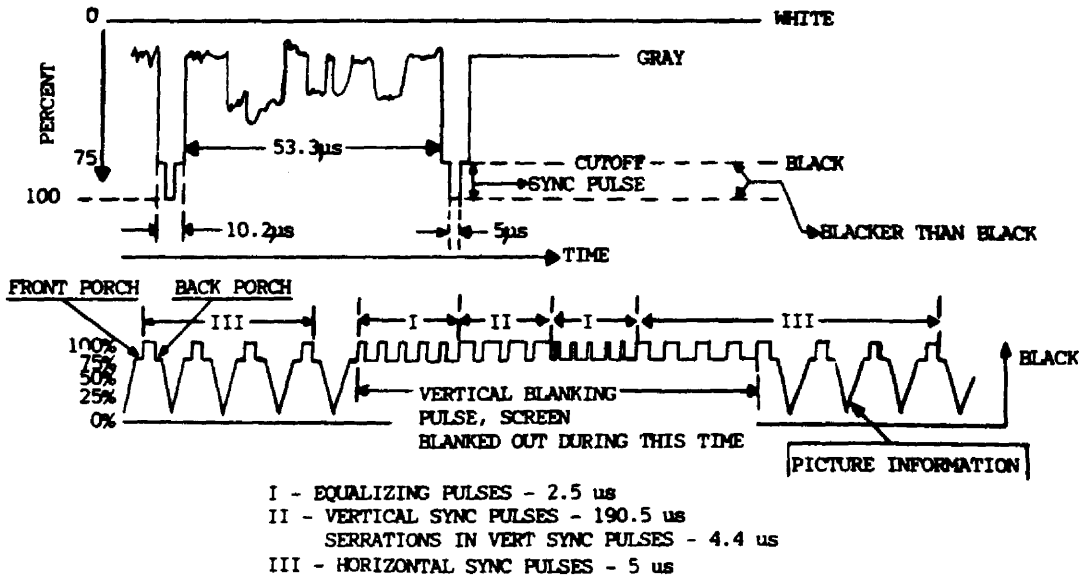
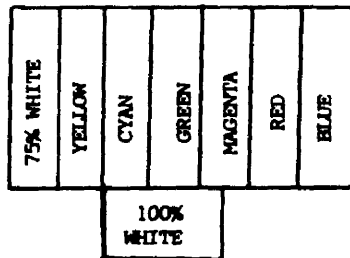
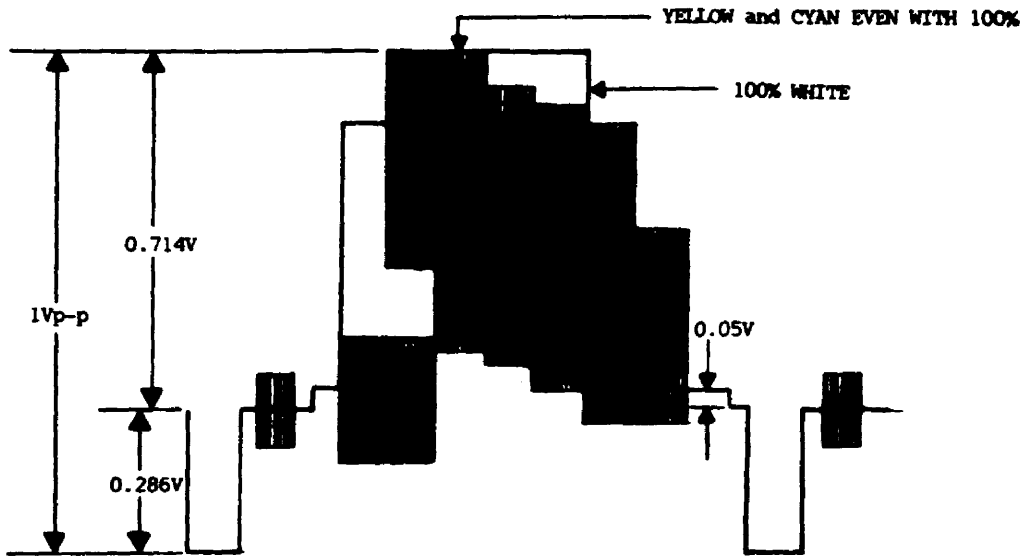

**COMPOSITE PICTURE SIGNAL**

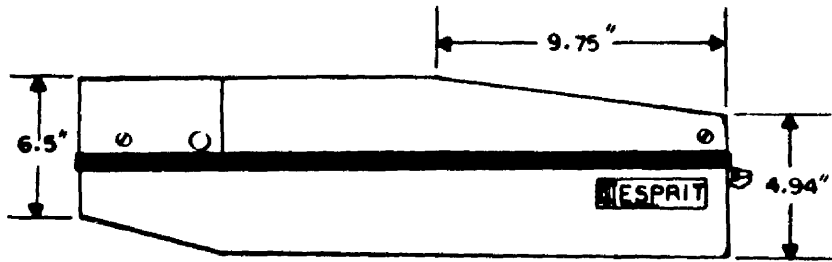

SIDE VIEW

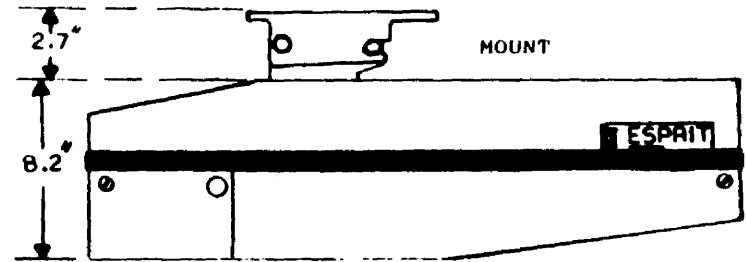

SIDE VIEW/W/CEILING MOUNT



REAR VIEW



FRONT VIEW

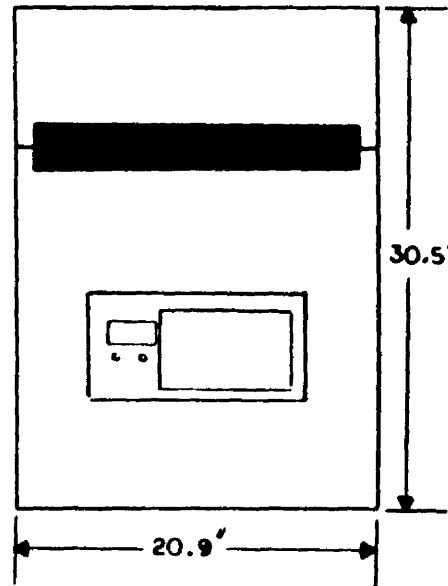

TOP VIEW

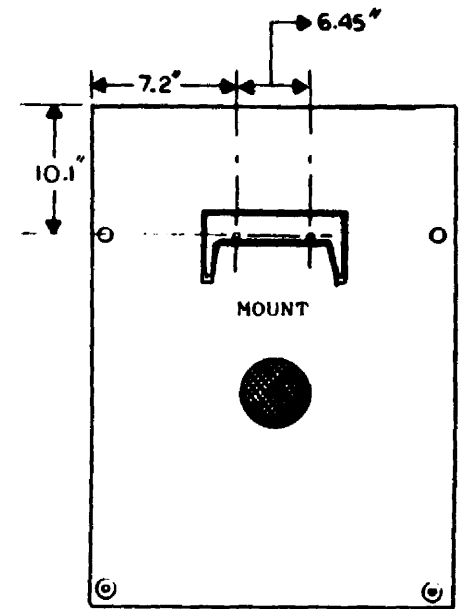

BOTTOM VIEW  
W/CEILING MOUNT

ESPRIT MODEL CASE WORK DIMENSION WITH CEILING/FLOOR MOUNT LOCATION



# 300/500/535 CONTROL LOCATIONS GUIDE

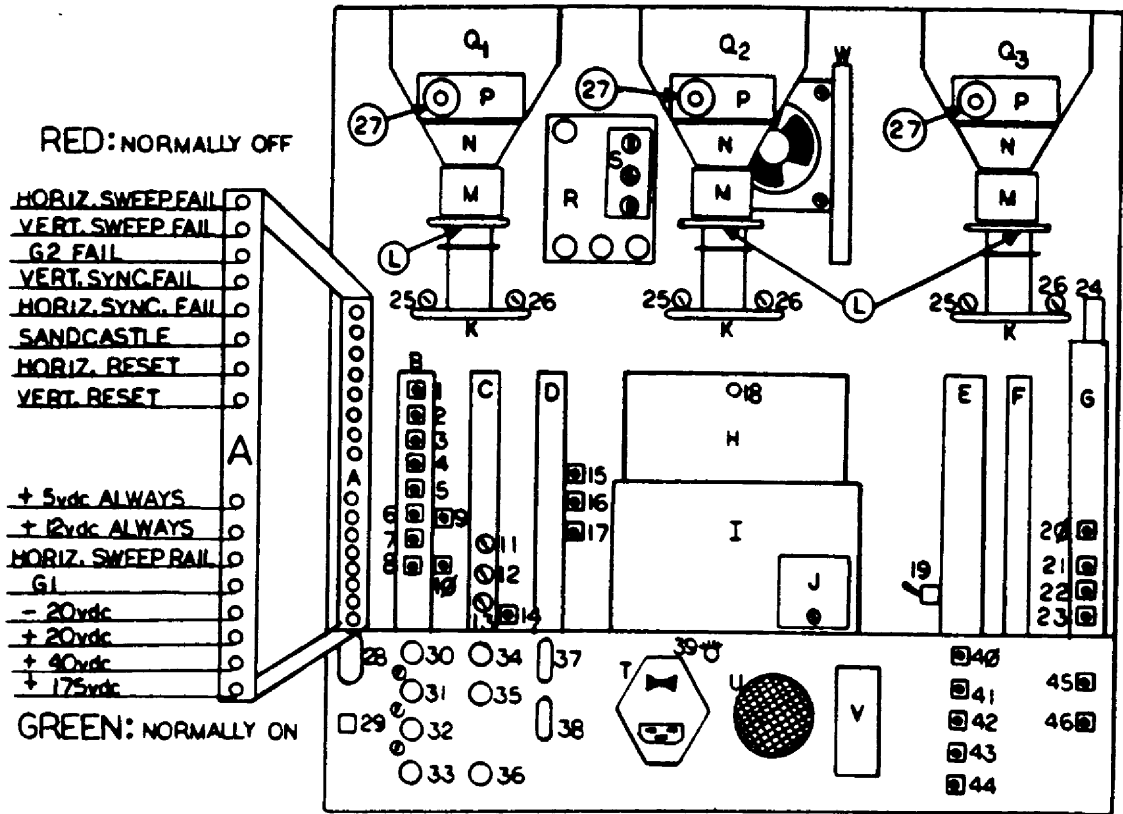

A	CPU module	1	Bottom blanking: NTSC	26	Black level adjustments
B	RGB module	2	Bottom blanking: PAL/Secam	27	Width coil adjustments
C	Quad Decoder module	3	Bottom blanking: RGB	28	RS232 port 535 only
D	TTL module (500/535)	4	Top blanking: NTSC	29	Remote Control input
E	Vertical Defl. module	5	Top blanking: PAL/SECAM	30	RED analog RGB input
F	Horizontal Defl. module	6	Top blanking: RGB	31	GRN analog RGB input
G	Horiz. Output module	7	Right side blanking:VIDEO	32	BLU analog RGB input
H	High Voltage module	8	Left side blanking: VIDEO	33	Comp sync. or H. drive in
I	SMPS module	9	Master sub-brite:RGB/VID.	34	Comp. video input BNC
J	Fuse panel if applicable	10	Master sub-cont.:RGB/VID.	35	Comp. video loop-thru BNC
K	CRT amp. module	11	RED sub-contrast:VIDEO	36	Vertical drive input BNC
L	Centering rings R,G,B	12	GRN sub-contrast:VIDEO	37	TTL input/9 pin "D"
M	Registration Coils	13	BLU sub-contrast:VIDEO	38	TTL loop-thru/9 pin "D"
N	Deflection Yokes	14	Master sub-contrast:VID.	39	Running light
P	Yoke interface p.c.b.	15	TTL GRN sub-contrast	40	BLU vertical size adjust
Q1	Red CRT	16	TTL RED sub-contrast	41	RED vertical size adjust
Q2	Green CRT	17	TTL BLU sub-contrast	42	Master vertical size adjust
Q3	Blue CRT	18	H.V. overvoltage indicator	43	Vertical linearity
R	H.V. Splitter	19	vertical sweep reverse	44	Vertical centering
S	Focus adjustment RGB	20	Horiz. centering 535 only	45	Master Pincushion (535)
T	Main A.C. switch/jack	21	Horiz. width 300/500	46	Master Keystone (535)
U	SMPS fan	22	Horiz. width 535		
V	Model/Serial number plt.	22	Master pincushion 300/500		
W	Bottom Fan interface pcb	23	Master keystone 300/500		
		24	Horiz. sweep reverse plug		
		25	G-2 adjustments		

CPU BOARD						RGB			QUAD STANDARD VIDEO			TTL / AUDIO			VERT. DEFLECTION		
J1			J2			J3			J4			J5			J6		
PIN	A	C	PIN	A	C	PIN	A	C	PIN	A	C	PIN	A	C	PIN	A	C
1		DIGITAL GND (J9-8)	1		SV. REV. (J8-5)	1		DIGITAL GND (J9-8)	1		DIGITAL GND (J9-8)	1		DIGITAL GND (J9-8)	1		ANALOG GND (J9-8)
2		+40V (J9-4)	2		V. REV. SENSE (J8-10)	2		DIGITAL GND (J9-8)	2		-20V (J9-1)	2		-20V (J9-1)	2		ANALOG GND (J9-8)
3	J5-4		3		V. SVP FAIL (J8-7)	3		+20V (J9-3)	3		+20V (J9-3)	3		+20V (J9-3)	3		SVP FAIL IN (J8-19)
4		TRACKING VOLTAGE (J9-9)	4		H. SVP FAIL (J9-8, J8-8)	4		-20V (J9-1)	4		J1-3A	4		J1-3A	4		STANDBY (J1-10C)
5			5			5		V. RESET (J8-15, J10-41)	5		PAL SEL (J2-22C)	5		VOLUME (J2-30A)	5		G2 (J28-2)
6			6		-20V (J9-1)	6		H. FLYBACK SAMPLE (J7-10, J8-14)	6		SECAM SEL (J2-22A)	6		15VPP H. SYNC (J3-27)	6	J7-25	J44-4
7			7		H. V. SAMPLE (J44-5)	7		H. RESET (J7-14, J10-43)	7		NTSC3.5 SEL (J2-21A)	7		BLU TTL (J3-29)	7		V. SVP FAIL (J2-3A)
8	AB (J10-9)	PATTERN SEL (J10-24)	8		CLAMP (J9-18)	8			8		NTSC4.4 SEL (J2-21C)	8			8		H. SVP FAIL (J2-4A)
9	TEST SEL (J4-20)	PATTERN ON (J10-22)	9		ON/OFF (J9-11)	9		V. RAMP (J10-48)	9		TINT (J2-20A)	9		GRN TTL (J3-26)	9		H. SAMPLE (J8-6)
10	NTSC EN (J3-11)	STANDBY (J8-4)	10			10		COMP SYNC OUT (J4-30, J8-11, J7-12)	10		DETAIL (J2-29A)	10		RED TTL (J3-24)	10		-20V (J9-1)
11	PAL/SECAM (J3-12)	TTL/VIDEO (J9-22)	11			11		NTSC ENABLE (J1-10A)	11		RED (J3-23)	11		TTL V. SYNC SVPP (J7-18)	11		COMP SYNC IN (J8-10)
12			12		G2 (J28-2)	12		PAL/SECAM EN (J1-11A)	12		BLUE (J3-20)	12		TTL H. SYNC SVPP (J3-18)	12		+20V (J9-3)
13			13			13		BEAM CURRENT (J4-28)	13		GREEN (J3-25)	13			13		COMP SYNC OUT (J7-10)
14		H. SYNC (J7-19)	14			14		V. BLANK OUT (J7-27, J10-21)	14			14		ANALOG GND (J9-8)	14		V. SYNC IN (J7-17)
15		ID1 (J7-9)	15		V. RESET (J8-15)	15		BRIGHTNESS (J2-20C)	15			15			15		V. RESET (J3-5, J10-41)
16	CS 2 (J10-5)	ID0 (J7-7)	16		G1 (J20-1)	16		CLAMP (J2-0A)	16			16			16		V. SV. REV. SENSE (J2-2C)
17	CS 3 (J10-7)	CS1 (J10-8)	17			17		CONTRAST (J2-27C)	17			17			17		V. RAMP (J8-25)
18	S1 (J10-10)	S2 (J10-0)	18			18		TTL H. SYNC (J5-12)	18			18			18		DIGITAL GND (J9-8)
19			19			19			19			19			19		DIGITAL GND (J9-8)
20			20			20		H. FLYBACK BLANK (J10-29)	20		TEST SEL (J1-9A)	20			20		V. 80V (J8-20)
21	+175V (J9-7)	SANDCASTLE (J4-25)	21		NTSC3.5 SEL (J4-7)	21		VIDEO/EXT RGB (J2-23A)	21		TEST VIDEO (J10-19)	21			21		BLU V. RET. (J14-1)
22			22		SECAM SEL (J4-6)	22		TTL/VIDEO (J1-11C)	22			22			22		GRN V. OUT (J15-9)
23			23		VIDEO/RGB (J7-29, J9-21)	23		RED DECODED (J4-11)	23			23			23		GRN V. RET (J15-1)
24	07 (J10-11)	D6 (J10-12)	24		RED CUTOFF (J11-10)	24		RED TTL (J5-10)	24			24		ANALOG GND (J9-8)	24		
25	05 (J10-13)	D4 (J10-14)	25		BLU H. SHIFT (J10-44)	25		GRN DECODED (J4-19)	25		SANDCASTLE (J1-22C)	25			25		RED V. RET. (J10-1)
26	02 (J10-16)	D3 (J10-15)	26		RED H. SHIFT (J10-42)	26		GRN TTL (J5-9)	26		BEAM I. LIMIT (J11.12.13-7)	26			26		
27	00 (J10-20)	D1 (J10-18)	27		CONTRAST (J4-26, J10-17)	27		TTL H. 15V SYNC (J5-8)	27		COLOR (J2-27A)	27			27		RED V. OUT (J10-9)
28		R/V (J10-17)	28		TINT (J4-9)	28		BLU DECODED (J4-12)	28		CONTRAST (J2-27C)	28			28		
29			29		DETAIL (J4-10)	29		BLU TTL (J5-7)	29		COMP VIDEO (J3-30)	29		ANALOG GND (J9-8)	29		
30	+12V ALWAYS (J9-12)	+5V (J10-3)	30		30 VOLUME (J5-5)	30		COMP VIDEO (J4-29)	30		COMP SYNC (J3-10)	30			30		BLU V. OUT (J14-3)
31	DIGITAL GND (J9-8)		31		+20V (J9-3)	31		ANALOG GND (J9-8)	31		VERT DRIVE (J7-28)	31		ANALOG GND (J9-8)	31		DIGITAL GND (J9-8)
32			32		ANALOG GND (J9-8)	32		ANALOG GND (J9-8)	32		ANALOG GND (J9-8)	32		ANALOG GND (J9-8)	32		DIGITAL GND (J9-8)

HORIZ. DEFLECTION			H.O.T. BD.			SMPS			REGISTRATION			DEFLECTION COIL		
J7			J8			J9			J10			J14		
PIN	A	C	PIN	A	C	PIN	A	C	PIN	A	C	PIN	A	C
1		ANALOG GND (J9-8)	1		ANALOG GND (J9-8)	1		-20V	1		DIGITAL GND (J9-8)	26		1 BLU V. RET. (J6-21)
2		ANALOG GND (J9-8)	2		ANALOG GND (J9-8)	2		-40V	2		DIGITAL GND (J9-8)	27		2 N/C
3		WIDTH TRACK (J8-7)	3			3		+20V	3		+5V (J1-91)	28		3 BLU V. (J8-30)
4		F/B TIME SEL (J8-0)	4		TRACKING VOLT. (J9-9)	4		+40V	4		+5V (J1-91)	29		3 GRN V. (J8-22)
5			5		SV. REV. (J2-1C)	5		6.0V FIL (J11.12.13-8)	5		CS2 (J1-10A)	30		
6		F/B TIME SEL (J8-10)	6		H. SAMPLE SVP (J8-9)	6		8.0V FIL NET (J11.12.13-5)	6		CS1 (J1-10C)	31		
7		ID1 (J1-15C)	7		WIDTH TRACKING (J7-9)	7		+175V (J11.12.13-4)	7		CS3 (J1-17A)	32		
8		H. DRIVE (J8-12)	8		F/B TIME SEL (J7-4)	8		ANALOG/DIGITAL GND SUM PT	8		CS2 (J1-10C)	33		
9		ID0 (J1-14C)	9			9		TRACKING VOLTAGE (J8-4)	9		AB (J1-17C)	34		
10		H. FLYBACK SAMP (J9-8, J8-14)	10		F/B TIME SEL (J7-8)	10		SMPS DRIVE PULSE (J7-26)	10		S1 (J1-10A)	35		
11			11			11		TURN-ON (J2-9A)	11		D7 (J1-24A)	36		H. SVP SAMPLE (J8-8)
12		COMP SYNC (J3-10)	12		H. DRIVE (J7-8)	12		+12V ALWAYS (J1-30)	12		D6 (J1-24C)	37		
13		H. SYNC (J1-13C)	13		SVP FAIL SIGNAL (J6-3)				13		D5 (J1-25A)	38		BLU V. SHIFT (J2-26A)
14		H. RESET (J9-7, J10-43, J2-9C)	14		FLYBACK SAMPLE (J7-18)				14		D4 (J1-25C)	39		
15		PHASING (J2-30C)							15		D3 (J1-26C)	40		RED V. SHIFT (J2-25A)
16		COMP SYNC IN (J8-13)							16		D2 (J1-28A)	41		V. RESET (J8-15)
17		V. SYNC OUT (J8-14, J1-12C)							17		R/V (J1-28C)	42		RED H. SHIFT (J2-20C)
18		TTL V. SYNC (J5-11)							18		D1 (J1-27C)	43		H. RESET (J9-7, J7-14)
19		TTL/VIDEO (J9-22)							19		D0 (J1-27A)	44		BLU H. SHIFT (J2-25C)
20		-20V (J9-1)							20		D0 (J1-27A)	45		LIN TRACKING (J2-29C)
21									21		V. BLANK (J9-14, J7-27)	46		VERT. RAMP (J3-9)
22		+20V (J9-3)							22		PATTERN ON (J1-9C)	47		DIGITAL GND (J9-8)
23									23		H. FLYBACK BLANK (J9-20)	48		DIGITAL GND (J9-8)
24		LINEARITY (J8-24)							24		PATTERN SEL (J1-0C)	49		ANALOG GND (J9-8)
25		HVPS DRIVE (J8-0A)							25			50		ANALOG GND (J9-8)
26		SMPS DRIVE (J9-10)												
27		V. BLANK (J9-14)												
28		V. DRIVE (J4-31)												
29		VIDEO/RGB (J3-21, J2-23A)												
30														
31		DIGITAL GND (J9-8)												
32		DIGITAL GND (J9-8)												



**ELECTRONIC SYSTEMS PRODUCTS, INC.**  
 1301 ARMSTRONG DRIVE  
 TITUSVILLE, FLORIDA U.S.A. 32780  
**ESPRITE INTERCONNECT**  
 300/500/535 REV X1  
 DATE: 31 MAY 1988 SHEET 1 OF 2

JUN 23 1988

CPU BOARD		RGB BOARD			QUAD STD. VIDEO DECODER BD			TTL BOARD (500/535)					
PIN	J16		PIN	J39	PIN	J40	PIN	J41		J20 (TTL IN)	J29 (LOOP THRU)		
1	SIGNAL	J21 RED BNC	1	ANALOG GND	1	ANALOG GND	1	ANALOG GND	J25 COMP VIDEO BNC	PIN	CGA	EGA	
2		J22 GRN BNC	2	RED VIDEO	2	GRN VIDEO	2	BLU VIDEO	J26 LOOP THRU BNC	1	DIGITAL GND	1	GND
3		J23 BLU BNC							J27 V.DRIVE	2		2	RED
4										3	RED	3	RED
5	DIGITAL GND	J24 COMP SYNC/H.SYNC BNC								4	GRN	4	GRN
6	-12V ALWAYS									5	BLU	5	BLU
										6	INTENSITY	6	GRN
										7	N/A	7	BLU
										8	H.SYNC +	8	H.SYNC +
										9	V.SYNC +	9	V.SYNC -

REGISTRATION BOARD						REGISTRATION DRIVER BOARD						YOKE BOARD										
PIN	J51		PIN	J50	PIN	J70	PIN	J52	PIN	J72	PIN	J40	PIN	J47	PIN	J48	PIN	J49	PIN	J50	PIN	J1
1	DIGITAL GND	26	1	RED H. OUT	1	GND	1	H FOC MOD	1	-20V	1	ANALOG GND	1	GND	1	RED HORIZ	1	GRN HORIZ	1	BLUE HORIZ	1	HORIZ SWEEP
2	DIGITAL GND	27	2	GRN H. OUT	2	-20V	2	V FOC MOD	2	+20V	2	+15V	2	-20V	2	H RETURN	2	H RETURN	2	H RETURN	2	N/C
3	+5V	28	3	BLU H. OUT	3	+20V	3		3	-15V	3	-15V	3	+20V	3	V RETURN	3	V RETURN	3	V RETURN	3	VERT SWEEP
4	+5V	29	4	RED V. OUT	4		4		4	+15V SV	4	+15V SV	4		4	RED VERT	4	GRN VERT	4	BLUE VERT	4	VERT SWEEP RETURN
5	CS2	30	5	GRN V. OUT	5		5		5	-15V SV	5	-15V SV	5		5		5		5		5	N/C
6	CST	31	6	BLU V. OUT	6		6		6	GND	6	N/C	6		6		6		6		6	HORIZ SWEEP RETURN
7	CS3	32	7	N/C	7		7		7	BLU V. IN	7	BLU V. IN	FOCUS MODULATOR									
8	S2	33	8	-15V SV	8		8		8	GRN V. IN	8	GRN V. IN	PIN	J73	PIN	J74	PIN	J75				
9	AD	34	9	+15V SV	9		9		9	RED V. IN	9	RED V. IN	1	GND	1	GND	1	FOC MOD OUT				
10	S1	35	10	-15V	10		10		10	BLU H. IN	10	BLU H. IN	2	+20V	2	N/C	2	N/C				
11	D7	36	11	+15V	11		11		11	GRN H. IN	11	GRN H. IN	3	V SIGNAL	3	600V	3	600V				
12	D8	37	12	ANALOG GND	12		12		12	RED H. IN	12	RED H. IN	4	H SIGNAL	4	H SIGNAL	4	H SIGNAL				
13	D5 TTL/VIDEO	38																				
14	D4 VIDEO/RGB	39																				
15	D3	40																				
16	D2 GRN CUTOFF	41																				
17	R/V	42																				
18	D1 BLU CUTOFF	43																				
19	TEST PATTERN	44																				
20	D0 RED CUTOFF	45																				
21	V. BLANKING	46																				
22	TEST PATTERN ON	47																				
23	H. FLYBACK BLANK	48																				
24	TEST PATTERN SEL	49																				
25	SENSE A	50																				

H.V.P.S. BOARD			S.M.P.S. BOARD					CRT CARD							
PIN	J42		PIN	J43	PIN	J44	PIN	J33		PIN	J31	PIN	J32	PIN	J1
1	FLYBACK IN	1	+20V	1	B+	1	-20V			1	CHASSIS GND	1	12V	1	G2
2	FLYBACK OUT	2	HV SAMPLE	2	B-	2	-40V			2	B-	2	12V	2	
3		3		3	GND	3	+20V			3	B+	3	GND	3	+20V
4	QUAD COM	4	GND	4		4	+40V			4	GND	4	L.E.D. RETURN	4	+175V
5	GND	5	HV DRIVE	5		5	FIL +6.3V	1	AC LINE	5		5		5	8.3V FIL RET
6	GND	6	+40V	6		6	FIL RET. 0.3V	2	AC LINE	6		6		6	8.3V RET
7	600V IN			7		7	+175V	3	AC TIED TO PIN 2	7		7		7	BEAM CURRENT LIMIT
8	200V IN			8		8	GND	4	AC TIED TO PIN 5	8		8		8	G1
				9		9	TRACKING H.SVP RAIL	5	AC NEUTRAL	9		9		9	GND
				10		10	SMP5 DRIVE PULSE			10		10		10	CUTOFF
				11		11	REMOTE TURN ON VOLTAGE								
				12		12	+12V								
PIN	J81	PIN	J82	PIN	J83										
1	G1	1	FEEDBACK	1	SPLITTER										
2	G2	2	QUAD COM	2	OVERVOLT										
		3	GND	3	N/C										
				2	N/C										
PIN	J84	PIN	J101												
1	FEEDBACK	1	+600V												
		2	N/C												
		3	N/C												
		4	GND												

 ELECTRONIC SYSTEMS PRODUCTS, INC.  
 1301 ARMSTRONG DRIVE  
 TITUSVILLE, FLORIDA U.S.A. 32790  
 ESPRIT INTERCONNECT  
 300/500/535 REV X1  
 DATE: 31 MAY 1988 SHEET 2 OF 2

7 JUN 23 1988

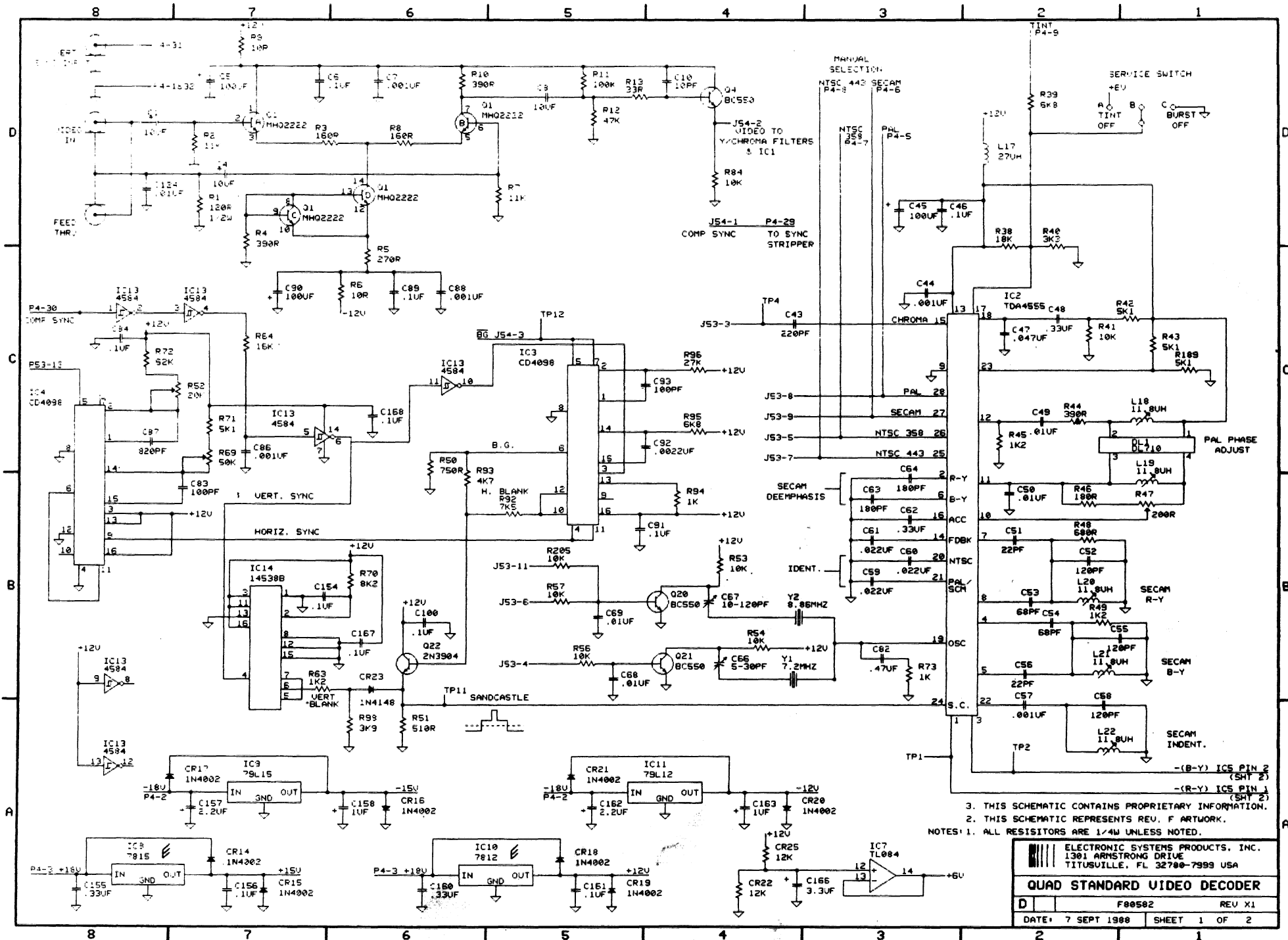

ELECTRONIC SYSTEMS PRODUCTS, INC.  
 1301 ARMSTRONG DRIVE  
 TITUSVILLE, FL 32780-7999 USA

**QUAD STANDARD VIDEO DECODER**

D	F00502	REV X1
DATE: 7 SEPT 1988	SHEET 1 OF 2	

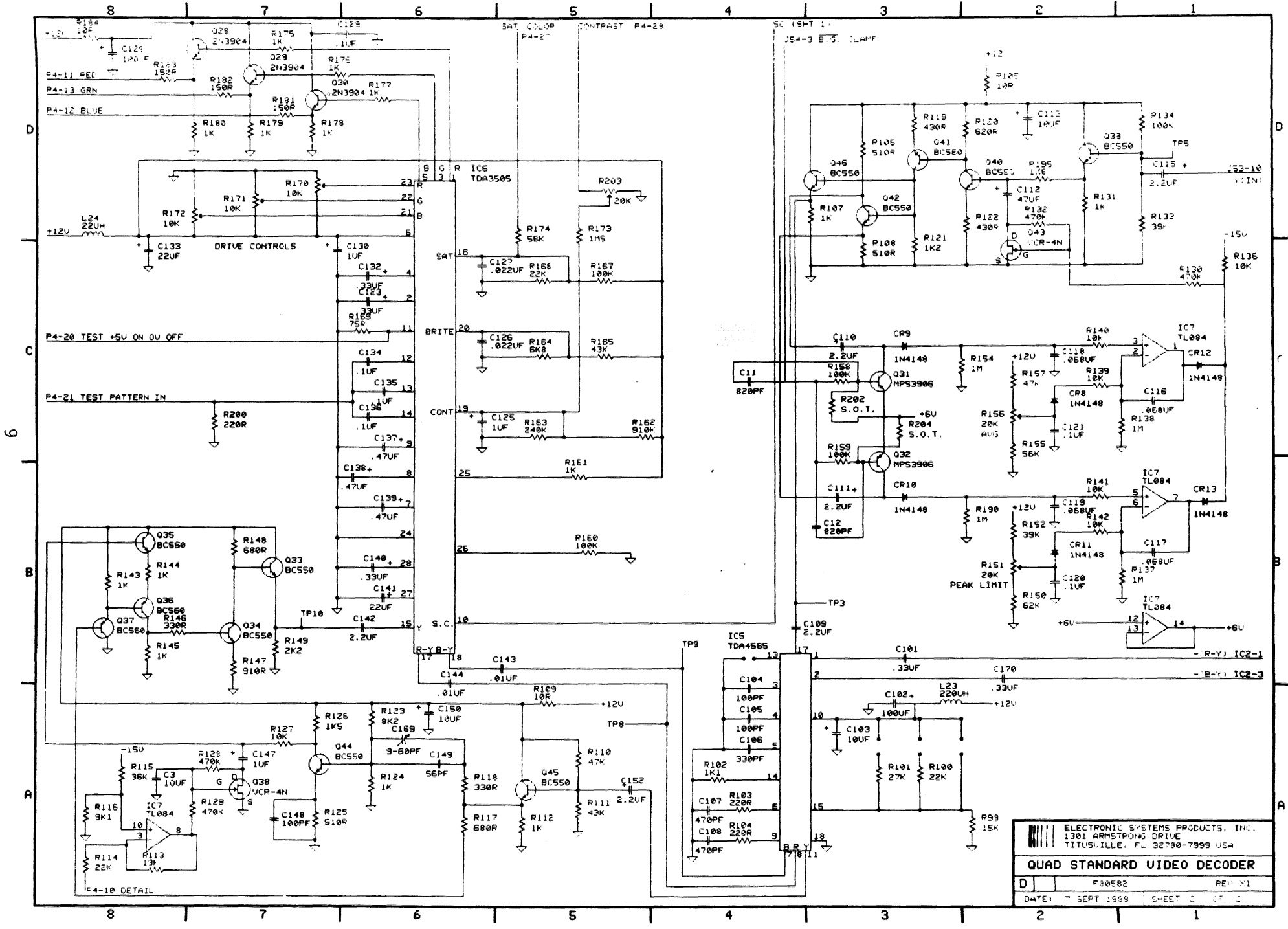

 ELECTRONIC SYSTEMS PRODUCTS, INC.  
 1301 ARMSTRONG DRIVE  
 TITUSVILLE, FL 32790-7999 USA  
**QUAD STANDARD VIDEO DECODER**  
 D F80582 REV. X1  
 DATE: SEPT 1988 SHEET 2 OF 2

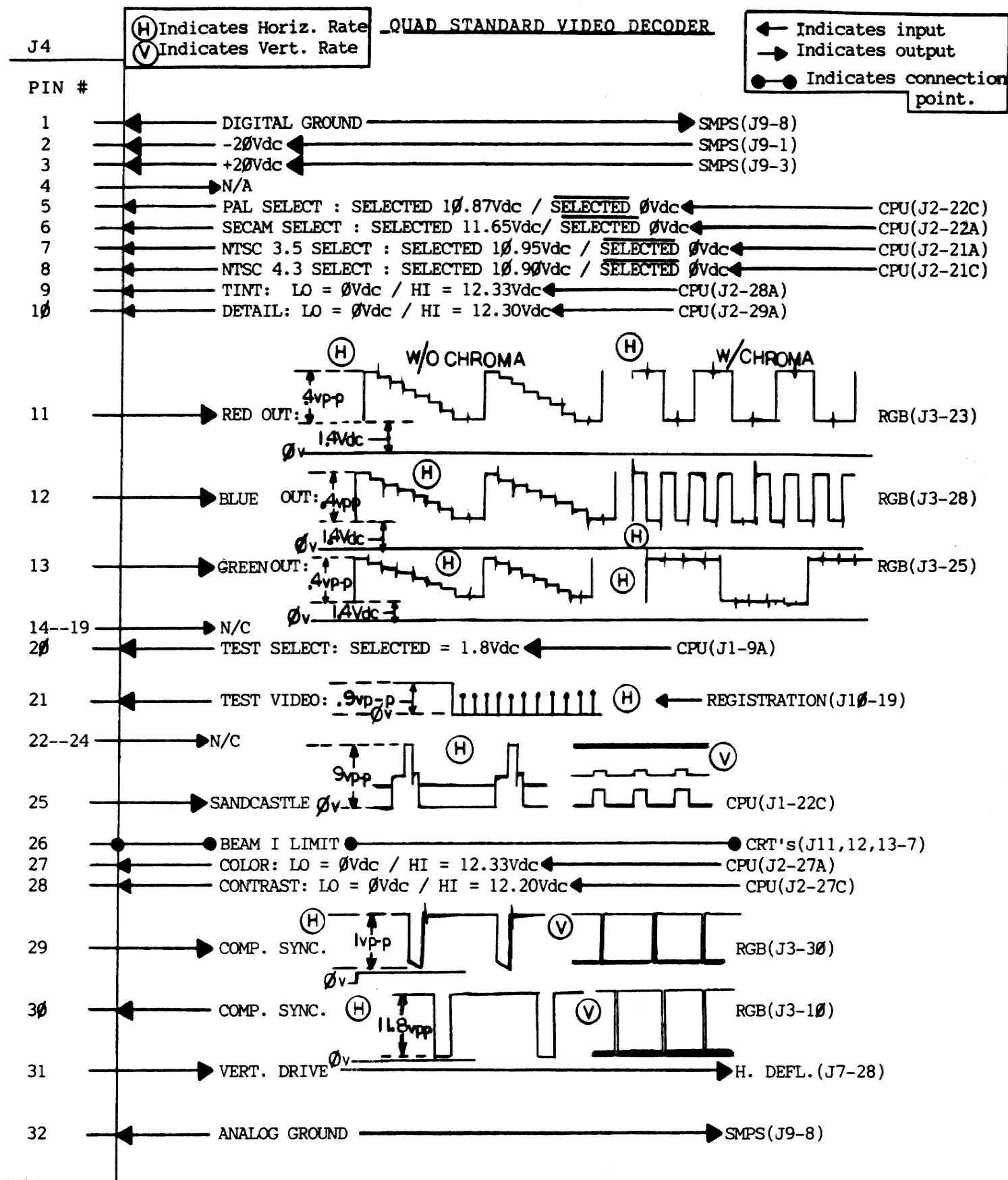

NOTE: TEST EQUIPMENT USED: B&K MODEL 1250 NTSC GENERATOR. NTSC BARS W/CHROMA (1vp-p)

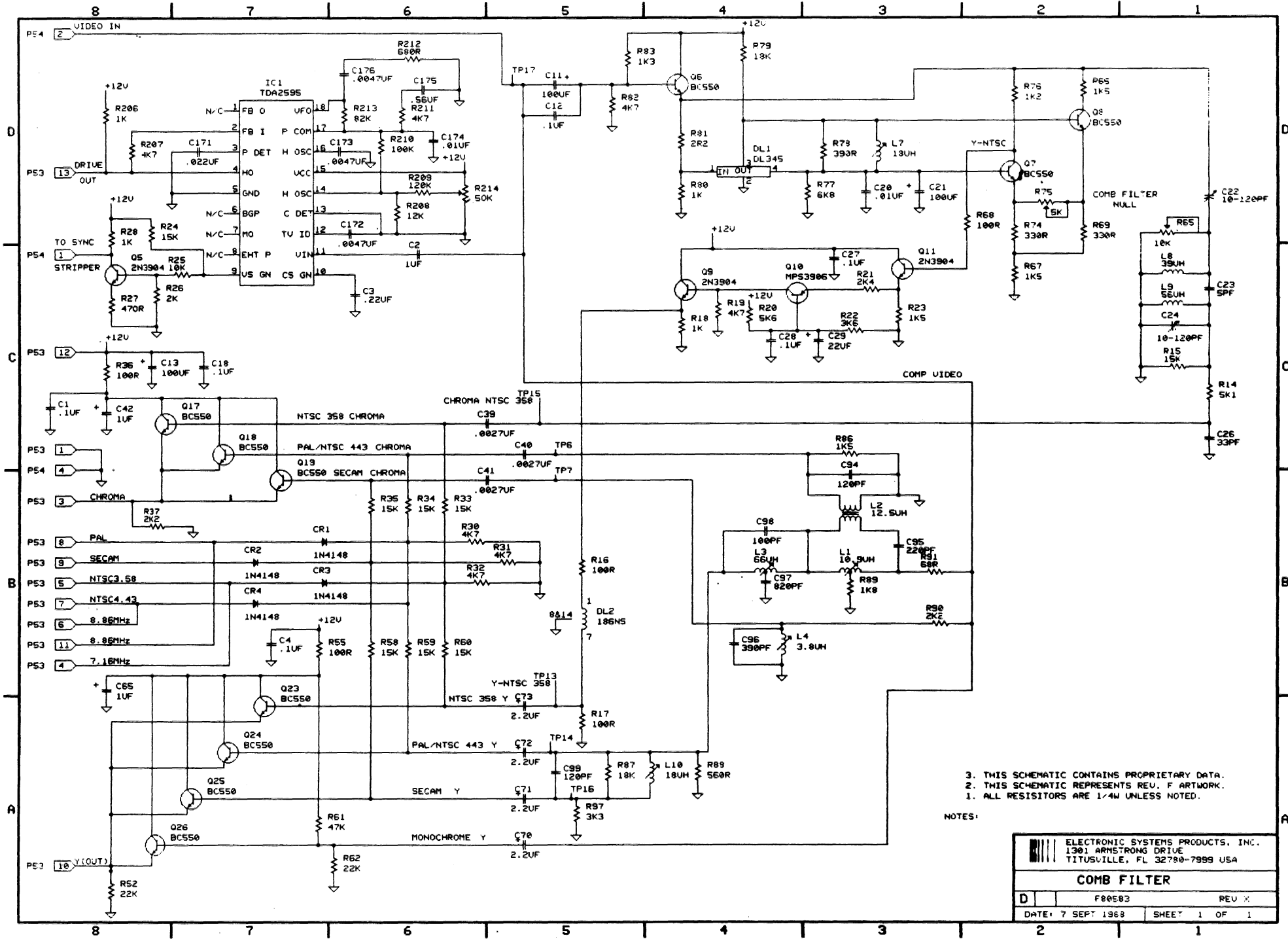

3. THIS SCHEMATIC CONTAINS PROPRIETARY DATA.  
 2. THIS SCHEMATIC REPRESENTS REV. F ARTWORK.  
 1. ALL RESISTORS ARE 1/4W UNLESS NOTED.

NOTES:

ELECTRONIC SYSTEMS PRODUCTS, INC. 1301 ARMSTRONG DRIVE TITUSVILLE, FL 32780-7999 USA			
<b>COMB FILTER</b>			
D	F80583	REV X	
DATE:	7 SEPT 1963	SHEET	1 OF 1

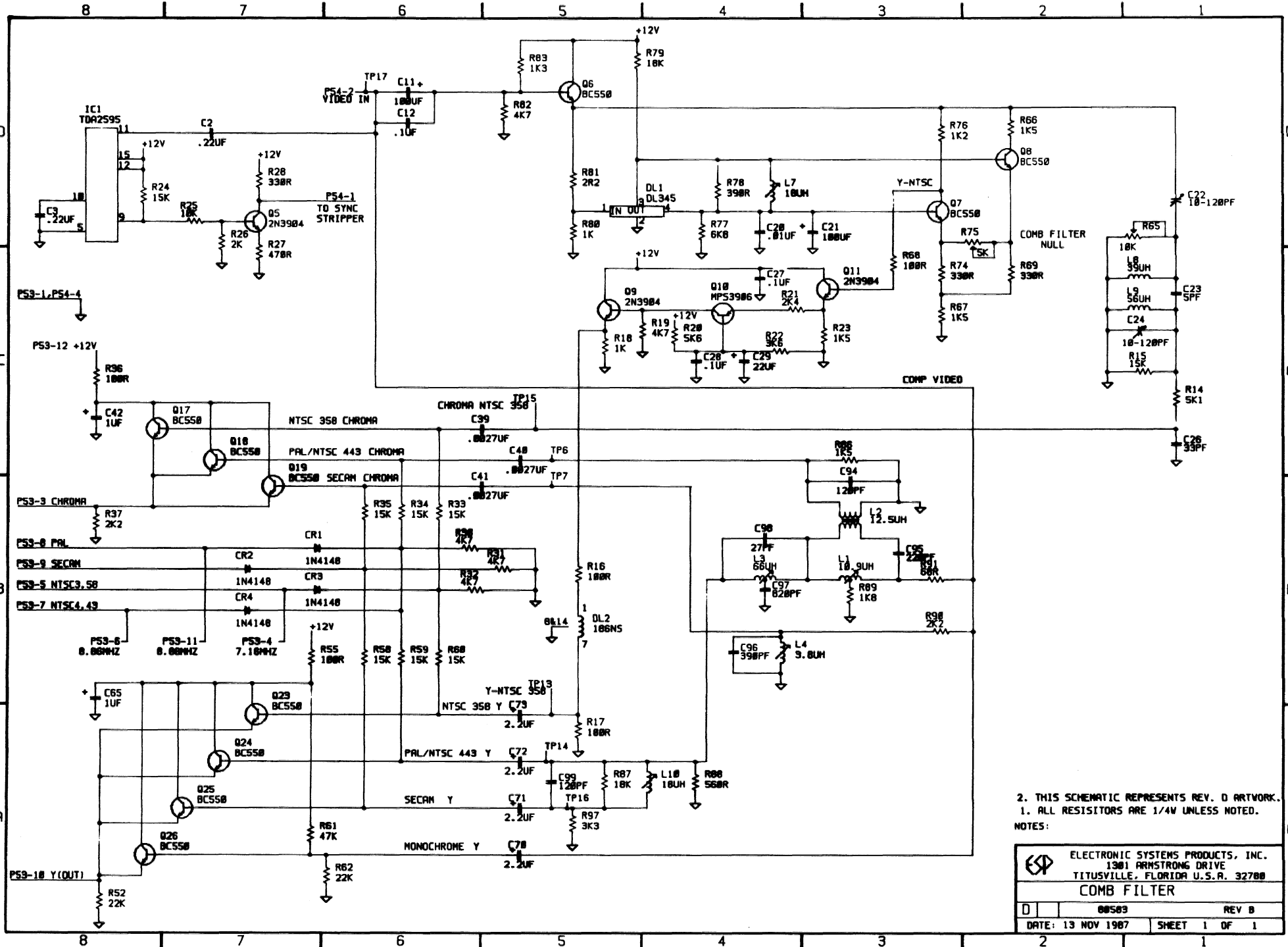

2. THIS SCHEMATIC REPRESENTS REV. D ARTWORK.  
 1. ALL RESISTORS ARE 1/4W UNLESS NOTED.

NOTES:

 ELECTRONIC SYSTEMS PRODUCTS, INC. 1301 ARMSTRONG DRIVE TITUSVILLE, FLORIDA U.S.A. 32780		
<b>COMB FILTER</b>		
D	00503	REV B
DATE: 13 NOV 1987	SHEET 1 OF 1	



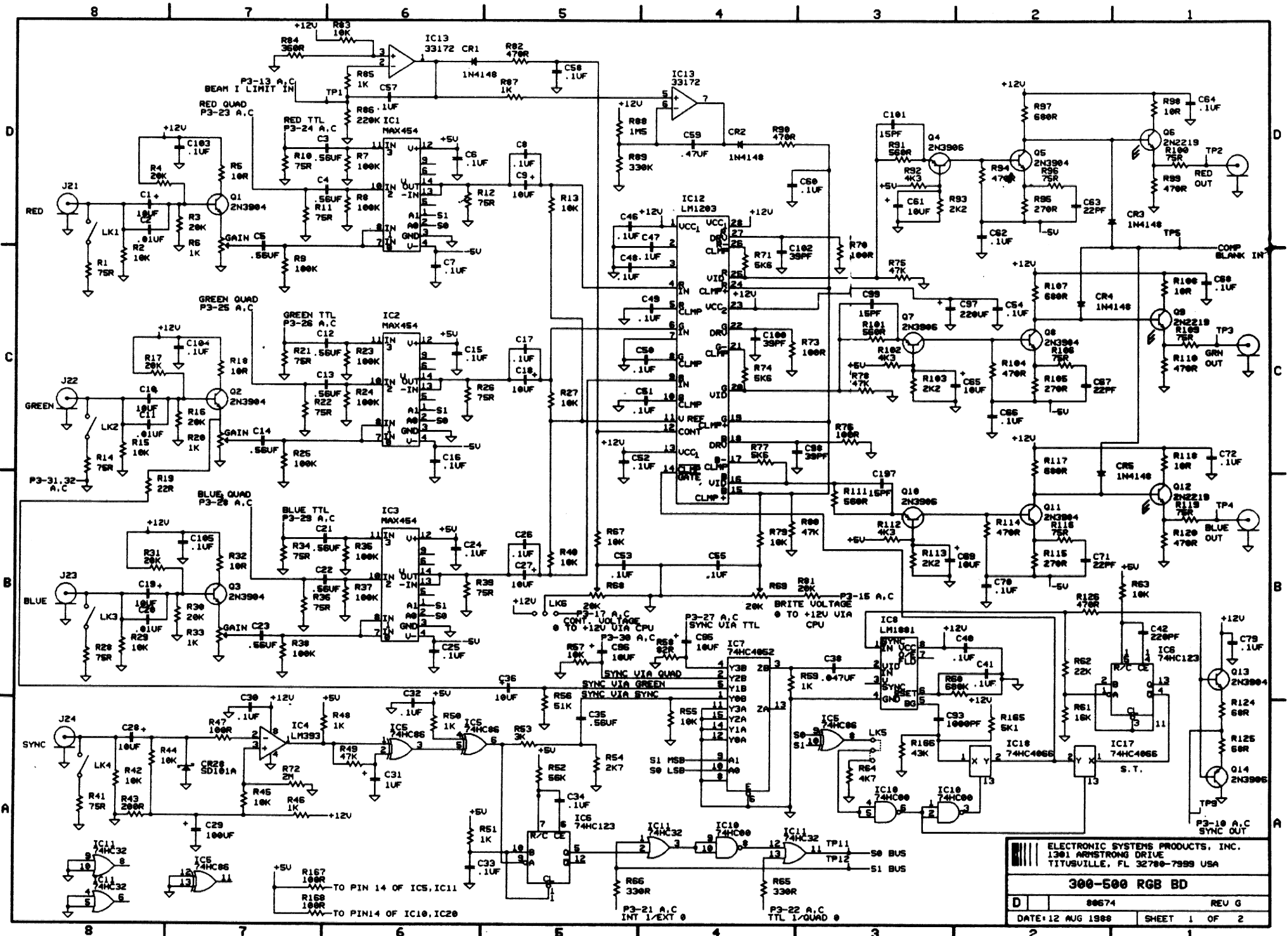

ELECTRONIC SYSTEMS PRODUCTS, INC.  
 1381 ARMSTRONG DRIVE  
 TITUSVILLE, FL 32796-7999 USA  
**300-500 RGB BD**  
 80674 REV G  
 DATE: 12 AUG 1988 SHEET 1 OF 2

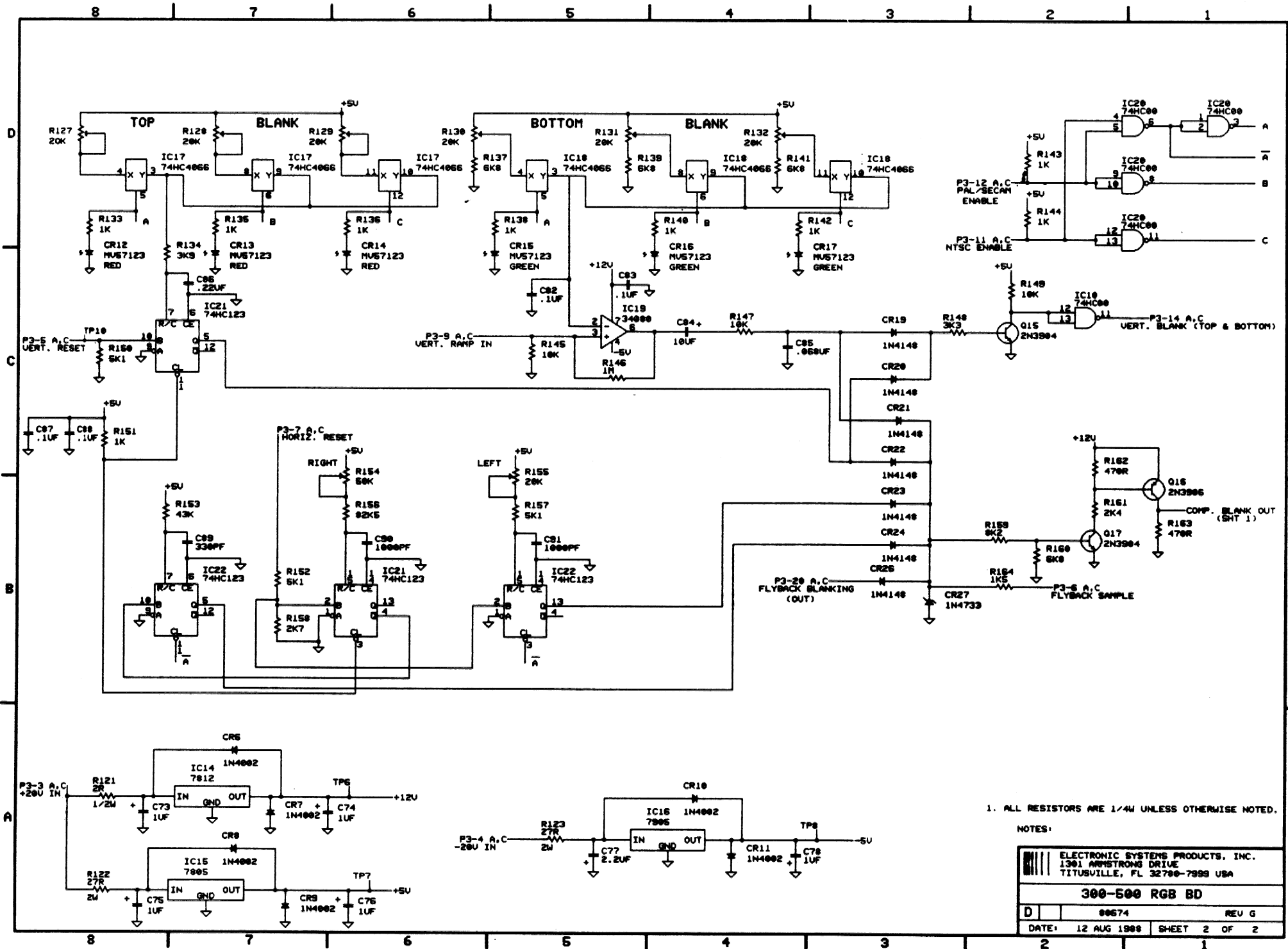

1. ALL RESISTORS ARE 1/4W UNLESS OTHERWISE NOTED.

NOTES:

ELECTRONIC SYSTEMS PRODUCTS, INC. 1301 ARMSTRONG DRIVE TITUSVILLE, FL 32790-7999 USA	
<b>300-500 RGB BD</b>	
D	00674 REV G
DATE: 12 AUG 1998	SHEET 2 OF 2

RGB MODULE

(H)	INDICATES HORIZ. RATE
(V)	INDICATES VERT. RATE
←	INDICATES INPUT
→	INDICATES OUTPUT
●●	INDICATES CONNECTION POINT

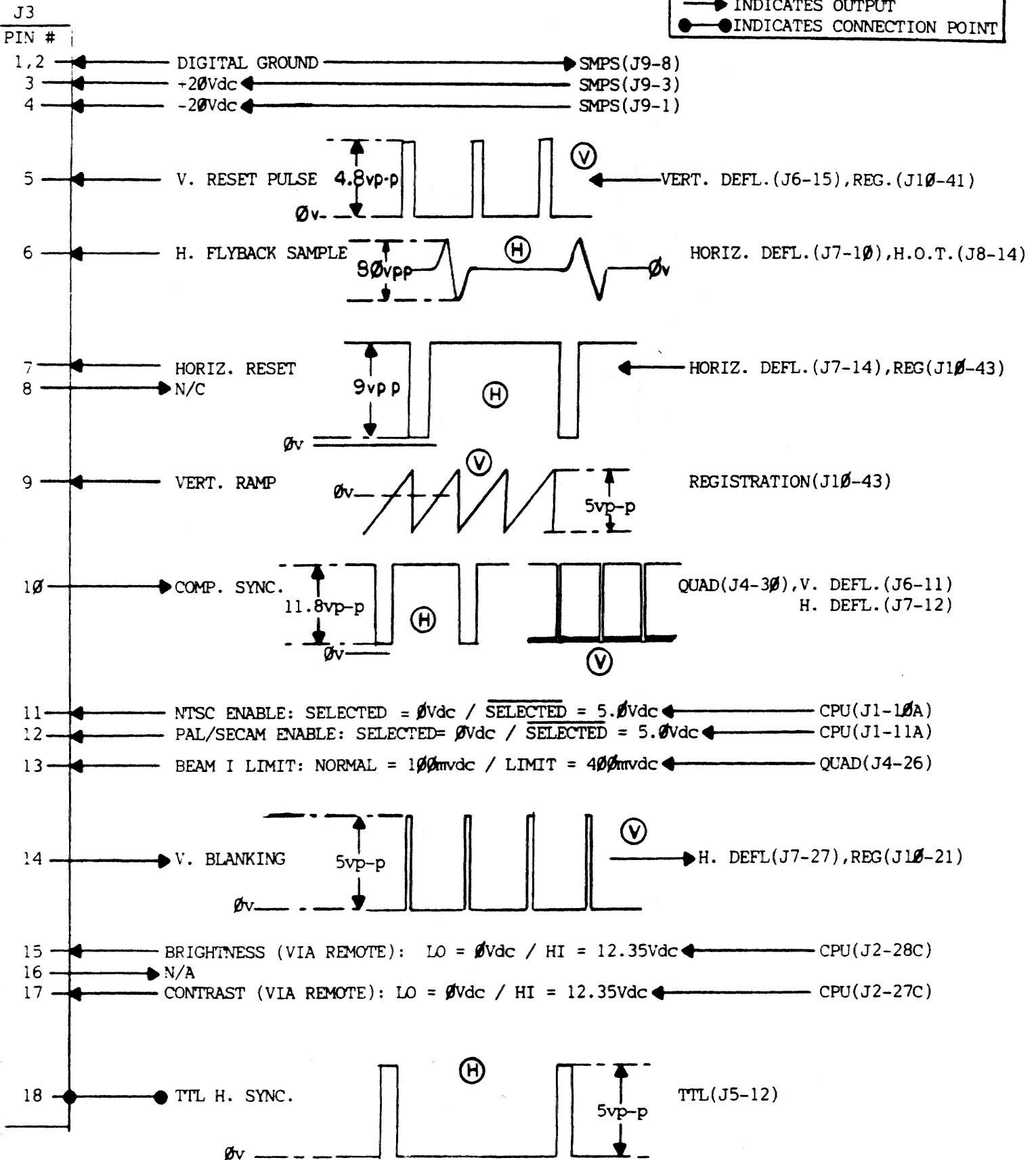

RGB MODULE

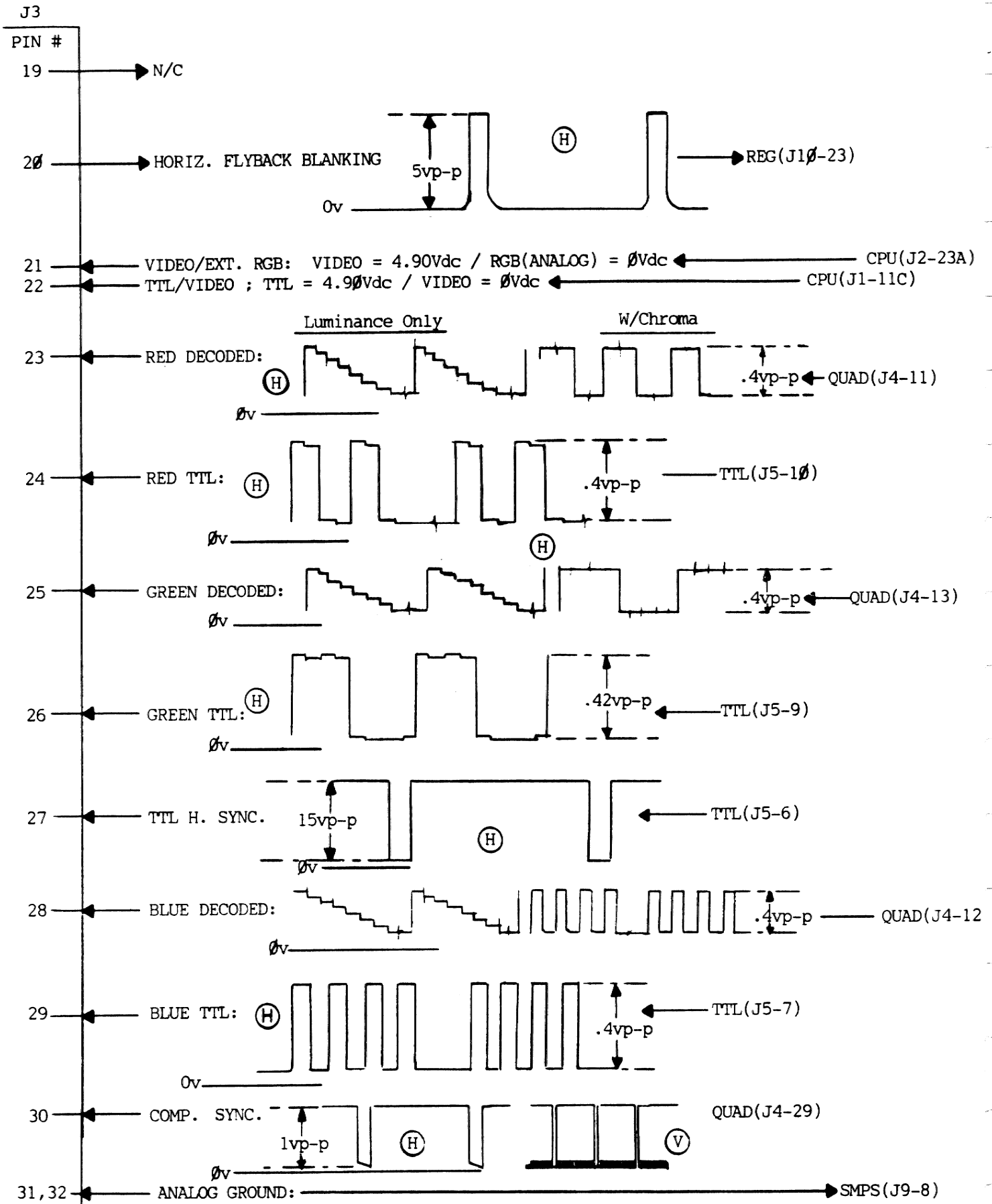

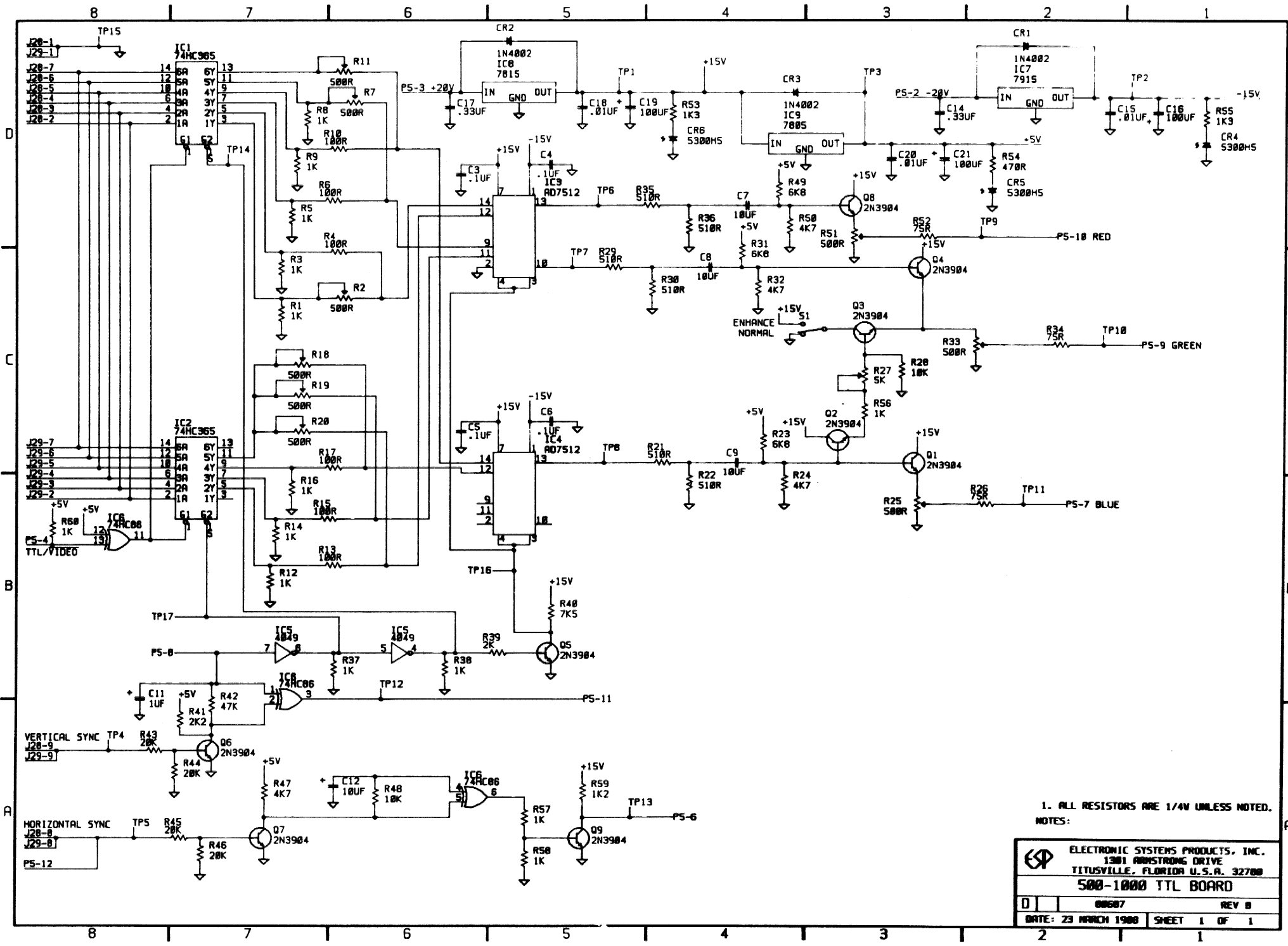

1. ALL RESISTORS ARE 1/4W UNLESS NOTED.  
 NOTES:

	ELECTRONIC SYSTEMS PRODUCTS, INC. 1301 ARMSTRONG DRIVE TITUSVILLE, FLORIDA U.S.A. 32780	
	<b>500-1000 TTL BOARD</b>	
	00687	REV B
DATE: 23 MARCH 1988		SHEET 1 OF 1

**TTL MODULE**

(H) INDICATES HORIZ. RATE  
 (V) INDICATES VERT. RATE  
 ← INDICATES INPUT  
 → INDICATES OUTPUT  
 ●● INDICATES CONNECTION POINT

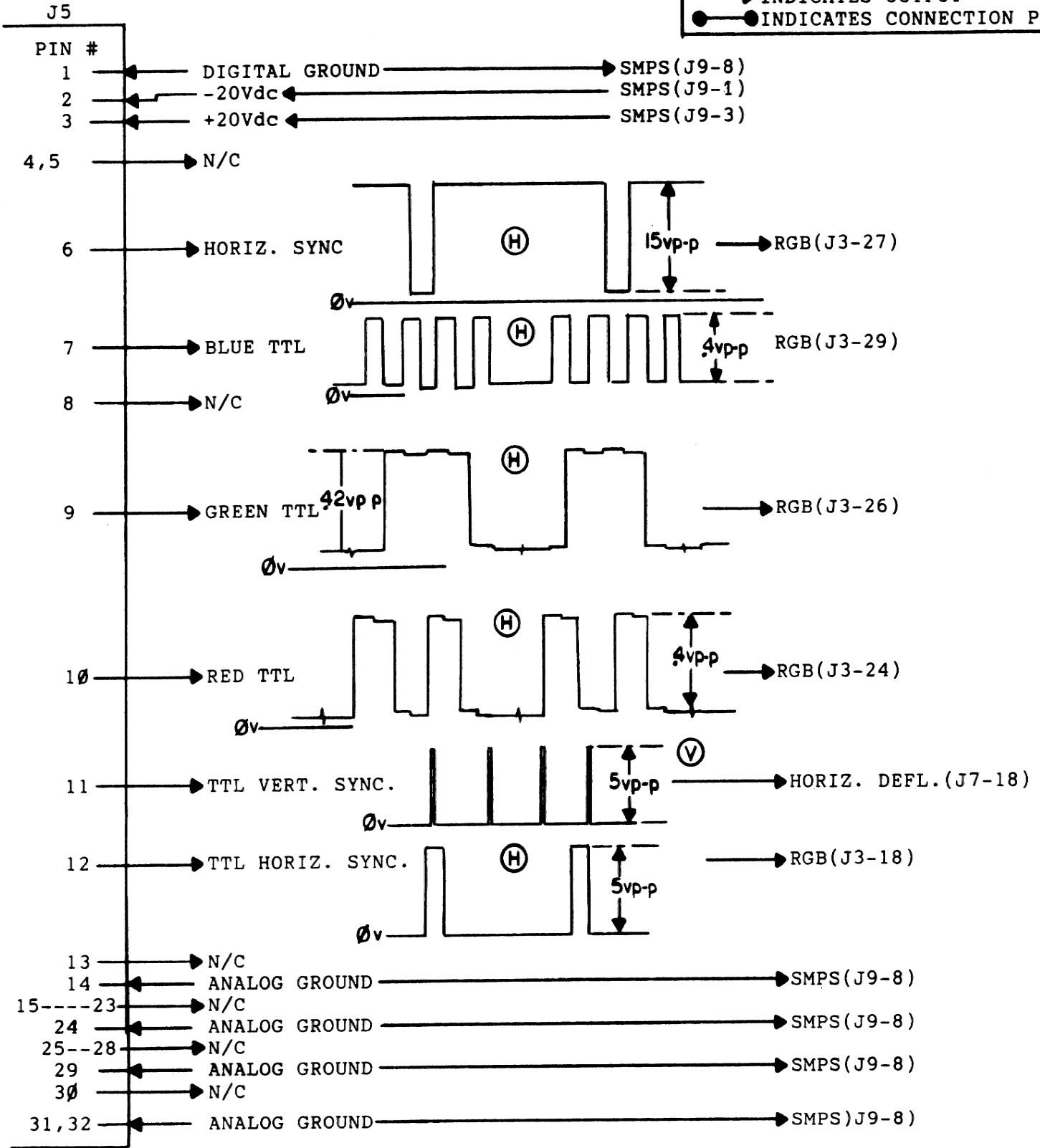

\*\*\* TTL SOURCE: B&K GENERATOR MODEL # 1249 @15.75KHz. (H) / 60Hz. (V)

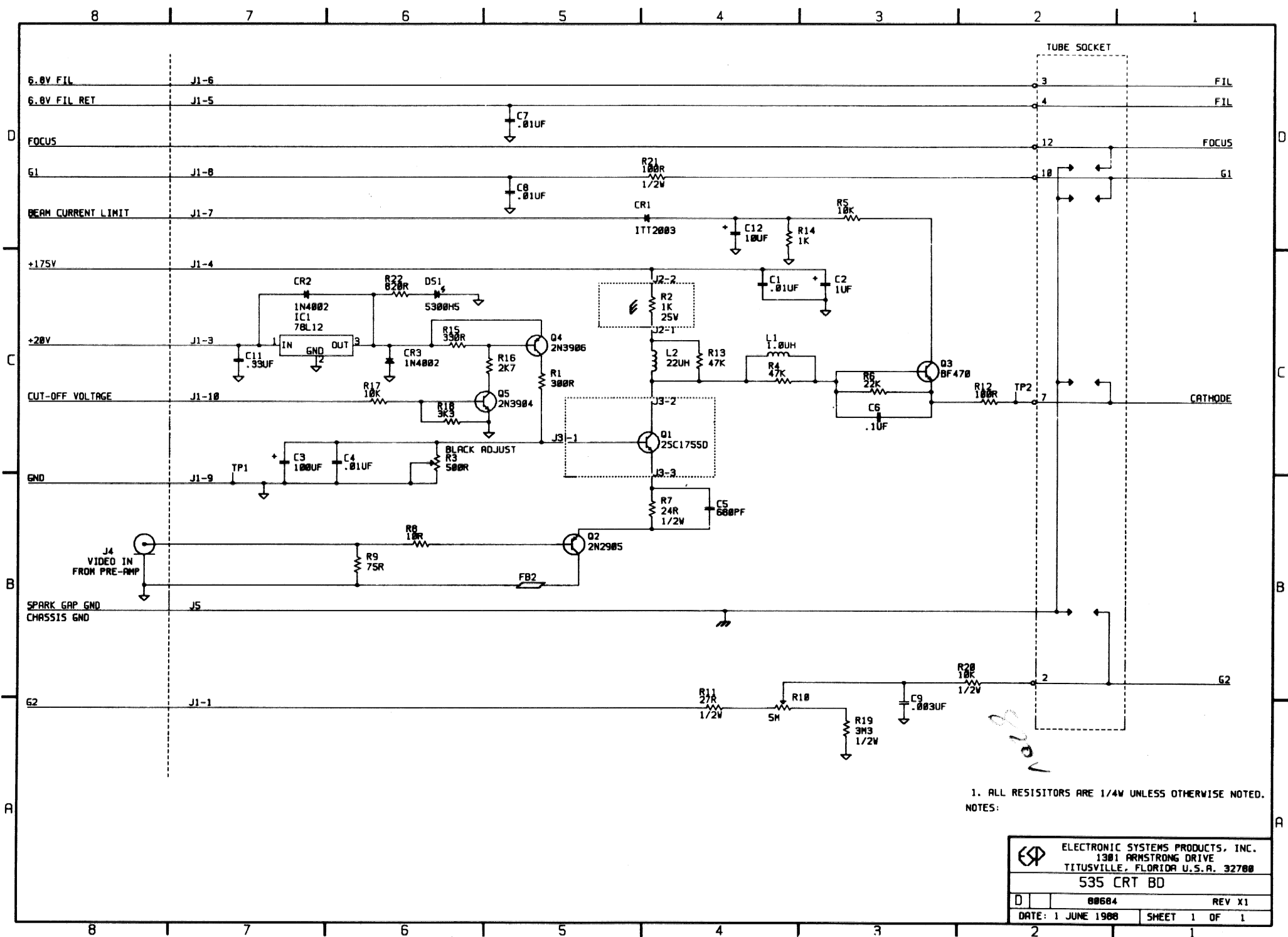

1. ALL RESISTORS ARE 1/4W UNLESS OTHERWISE NOTED.  
 NOTES:

 ELECTRONIC SYSTEMS PRODUCTS, INC. 1301 ARMSTRONG DRIVE TITUSVILLE, FLORIDA U.S.A. 32700		
535 CRT BD		
D	00684	REV X1
DATE: 1 JUNE 1968	SHEET 1 OF 1	

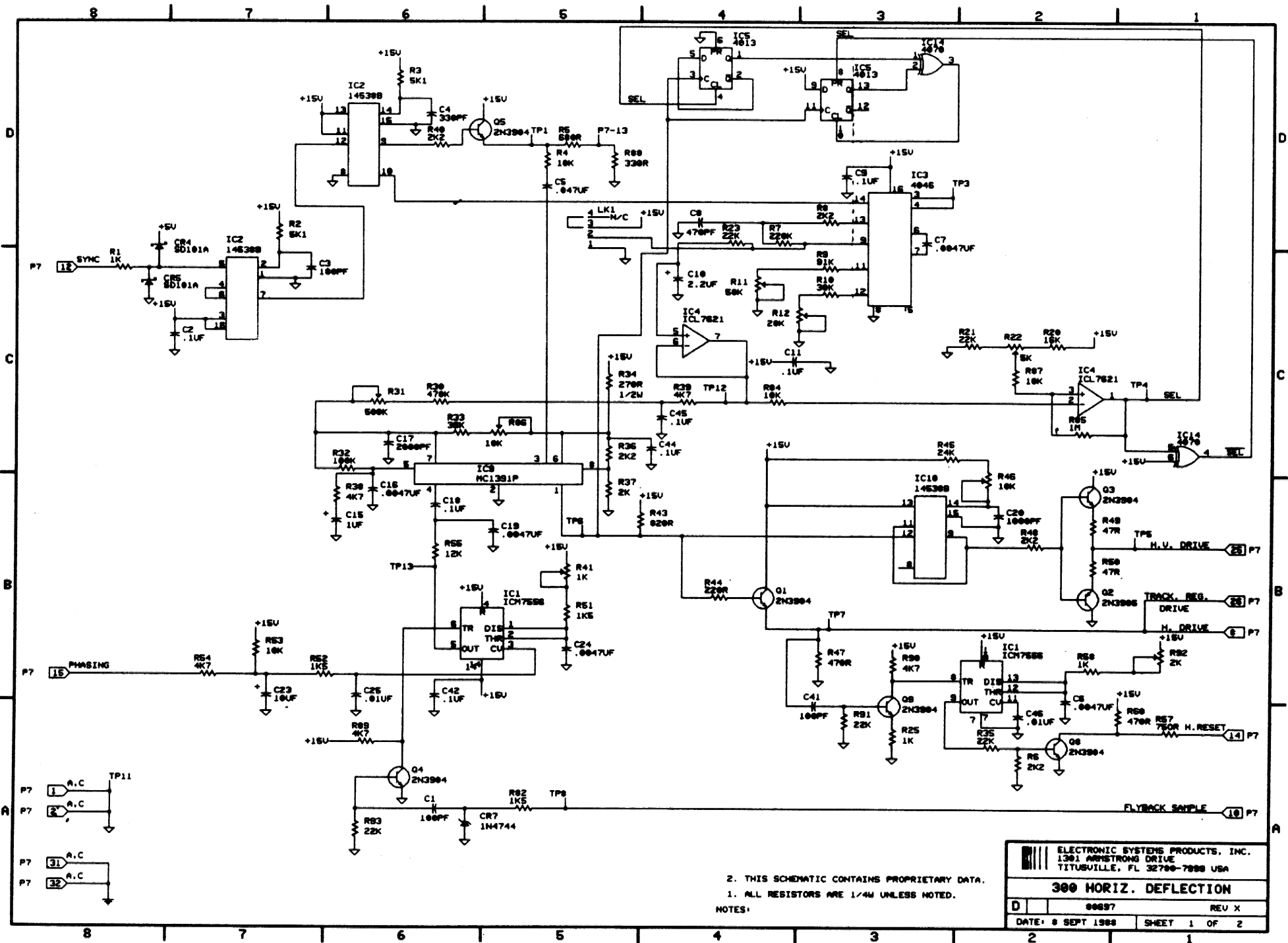

2. THIS SCHEMATIC CONTAINS PROPRIETARY DATA.  
 1. ALL RESISTORS ARE 1/4W UNLESS NOTED.  
 NOTES:

ELECTRONIC SYSTEMS PRODUCTS, INC. 1301 ARMSTRONG DRIVE TITUSVILLE, FL 32790-7998 USA		
<b>300 HORIZ. DEFLECTION</b>		
D	00897	REV X
DATE: 8 SEPT 1988	SHEET 1 OF 2	



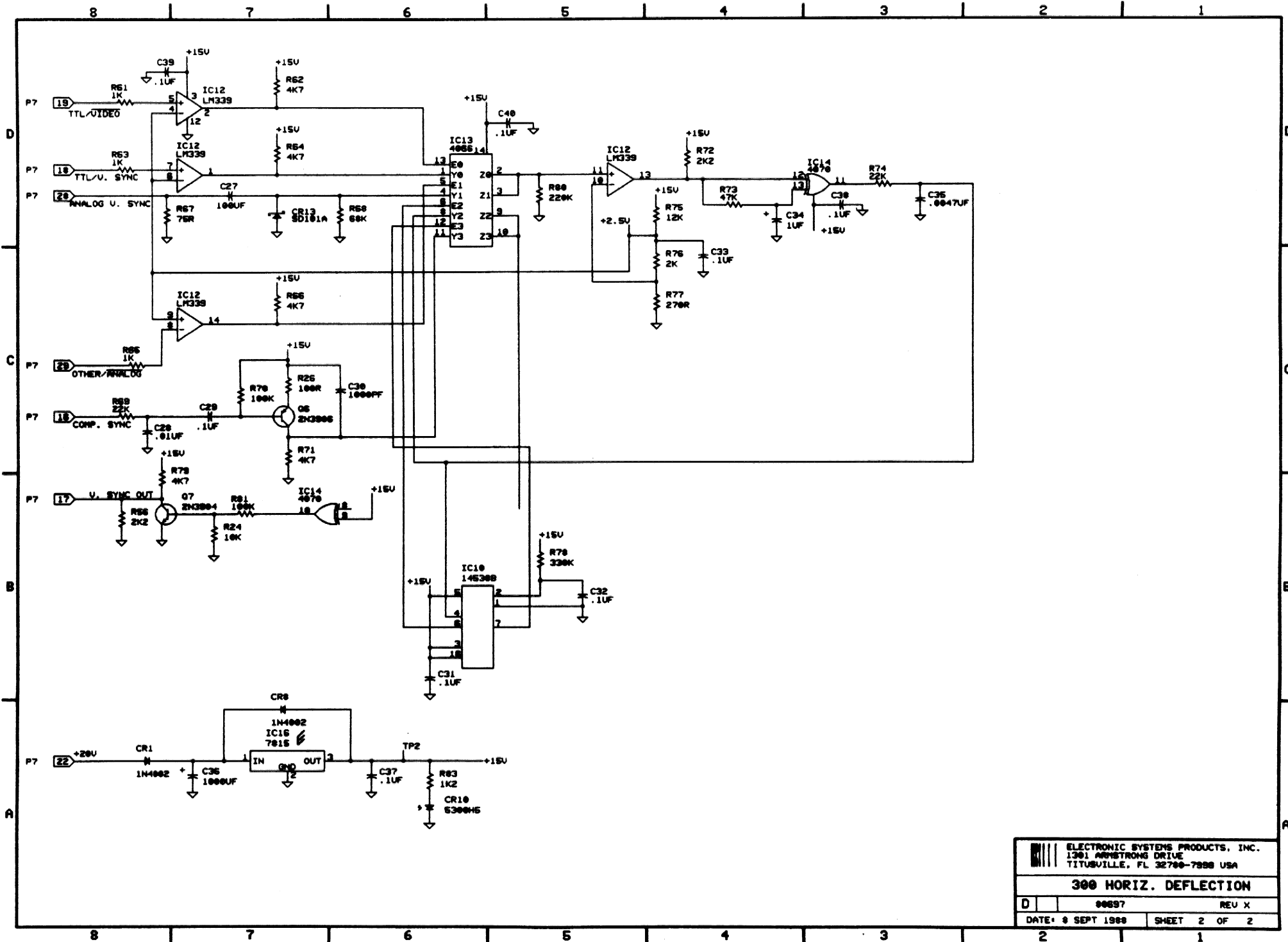

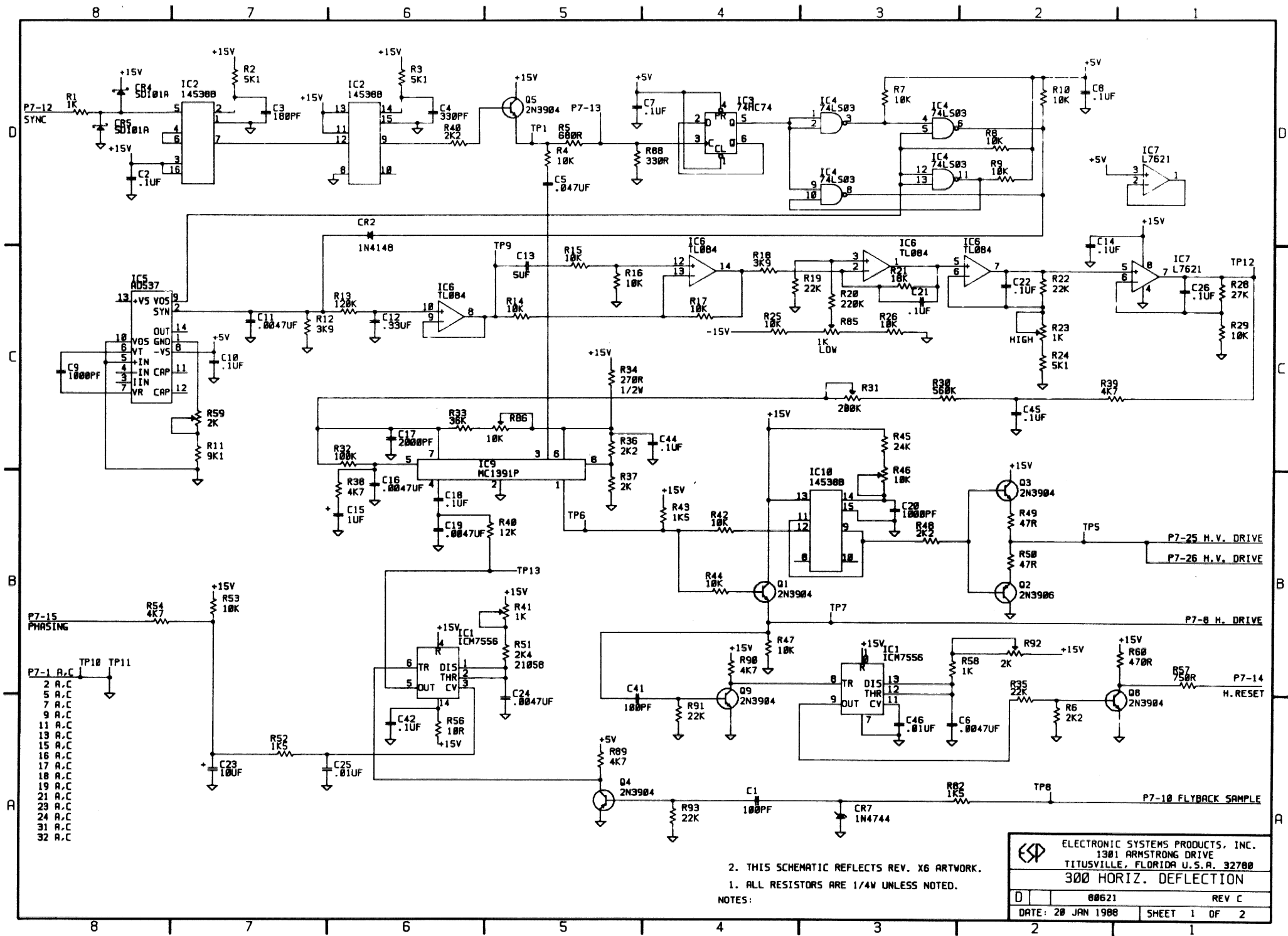

**ELECTRONIC SYSTEMS PRODUCTS, INC.**  
 1301 ARMSTRONG DRIVE  
 TITUSVILLE, FL 32780-7998 USA  
**300 HORIZ. DEFLECTION**  
 D 00097 REV X  
 DATE: 9 SEPT 1988 SHEET 2 OF 2



2. THIS SCHEMATIC REFLECTS REV. X6 ARTWORK.  
 1. ALL RESISTORS ARE 1/4W UNLESS NOTED.

NOTES:

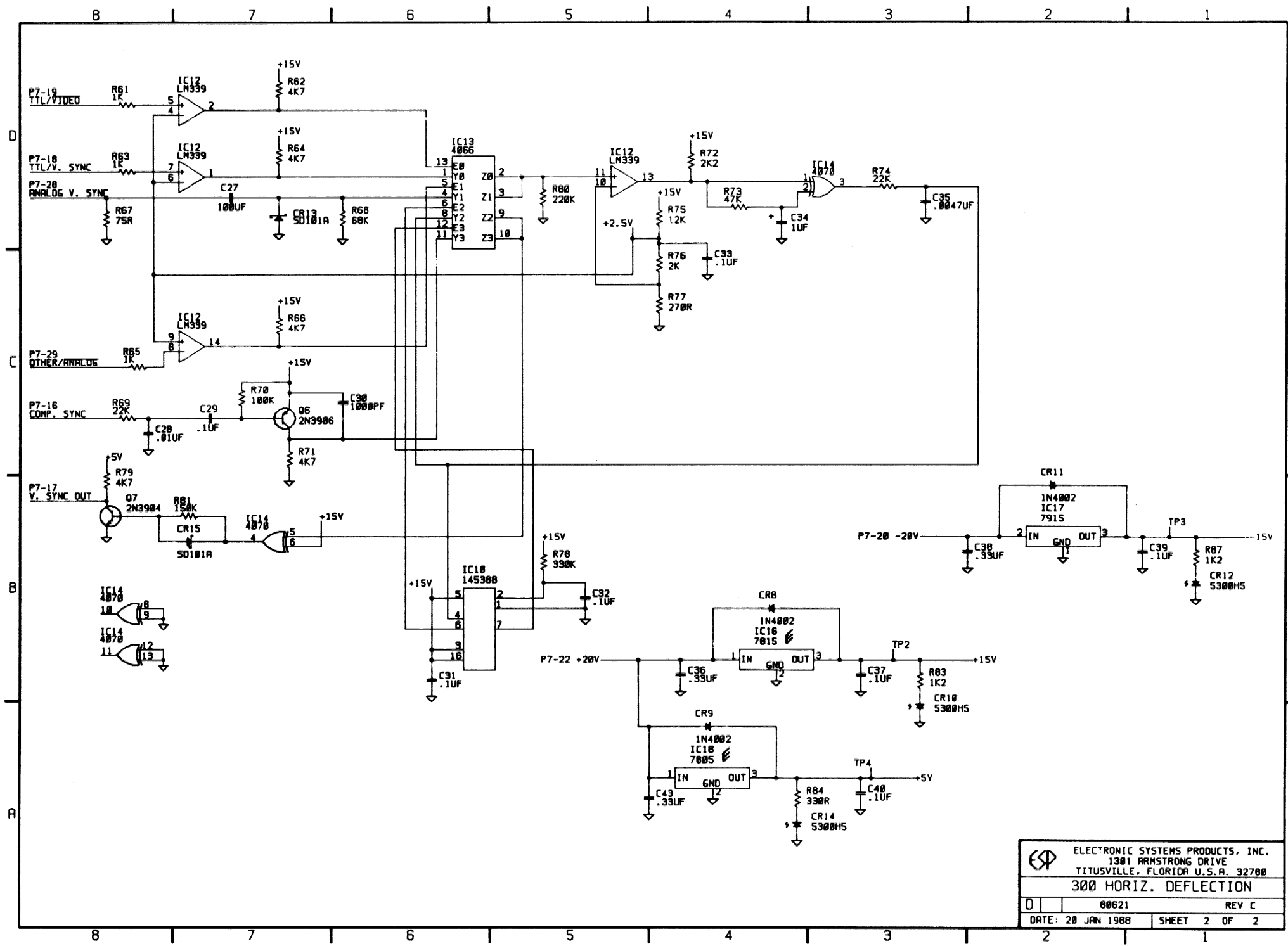
 ELECTRONIC SYSTEMS PRODUCTS, INC. 1301 ARMSTRONG DRIVE TITUSVILLE, FLORIDA U.S.A. 32700		300 HORIZ. DEFLECTION	
		D	80621
DATE: 20 JAN 1988	SHEET 1	OF 2	



 ELECTRONIC SYSTEMS PRODUCTS, INC. 1301 ARMSTRONG DRIVE TITUSVILLE, FLORIDA U.S.A. 32700		
		<b>300 HORIZ. DEFLECTION</b>
D	00621	REV C
DATE: 20 JAN 1988		SHEET 2 OF 2

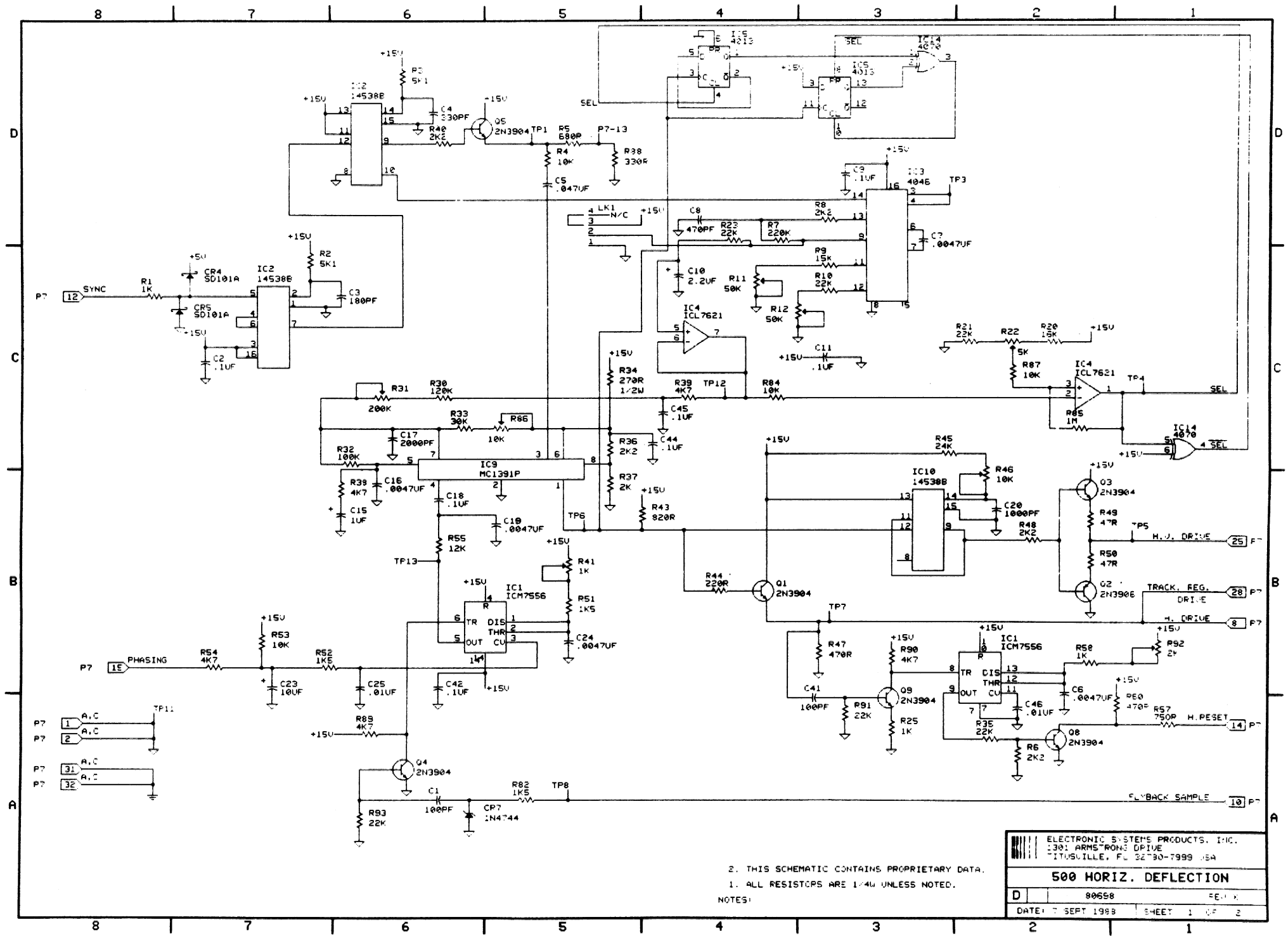

2. THIS SCHEMATIC CONTAINS PROPRIETARY DATA.  
 1. ALL RESISTORS ARE 1/4W UNLESS NOTED.

NOTES:

ELECTRONIC SYSTEMS PRODUCTS, INC. 1301 ARMSTRONG DRIVE TITUSVILLE, FL 32780-7999 USA		
<b>500 HORIZ. DEFLECTION</b>		
D	90658	REV. X
DATE: 7 SEPT 1988		SHEET 1 OF 2

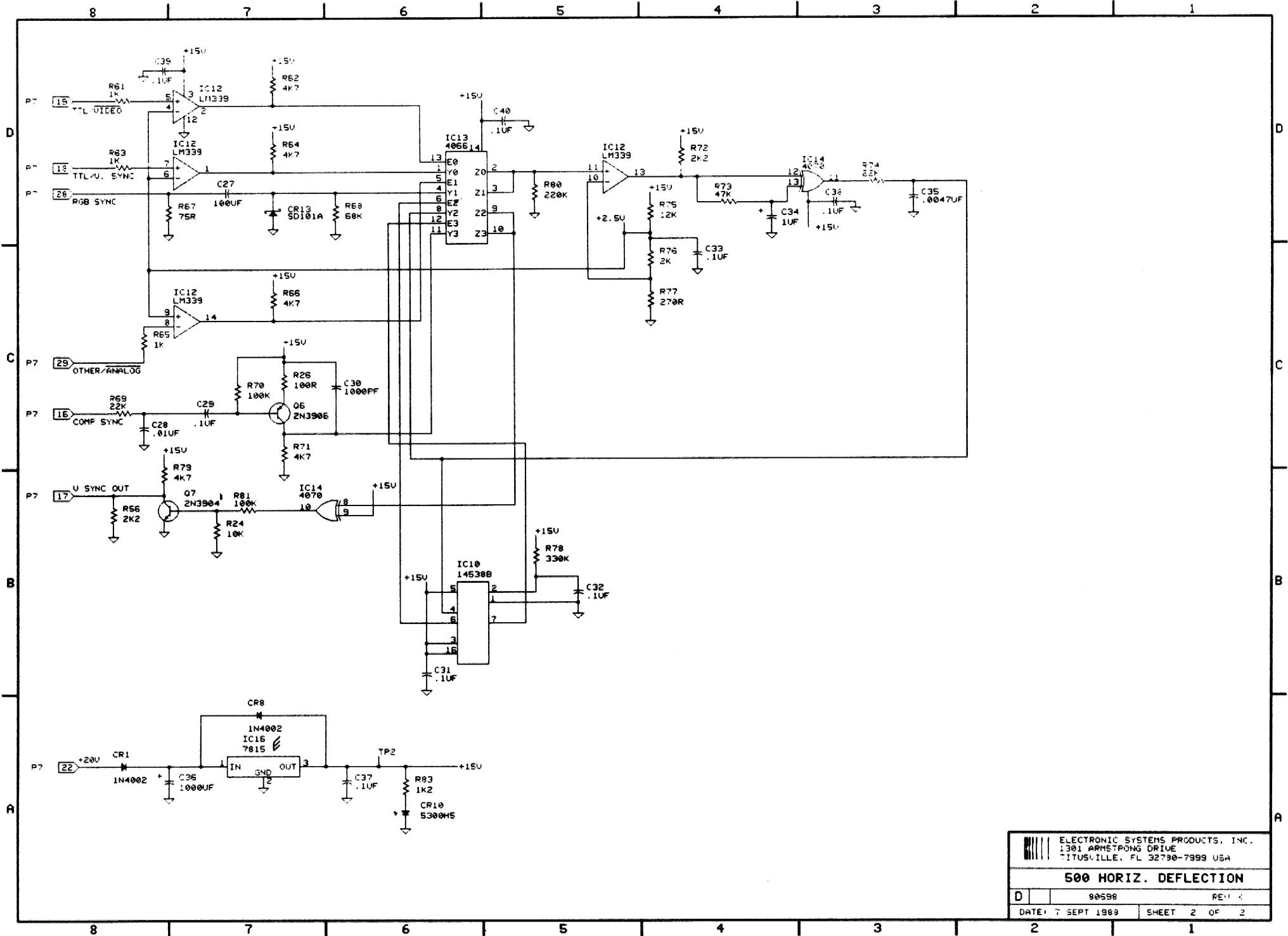

 ELECTRONIC SYSTEMS PRODUCTS, INC.  
 1301 ARMSTRONG DRIVE  
 TITUSVILLE, FL 32790-7999 USA

**500 HORIZ. DEFLECTION**

D	90598	REV. 1
DATE: 7 SEPT 1989		SHEET 2 OF 2

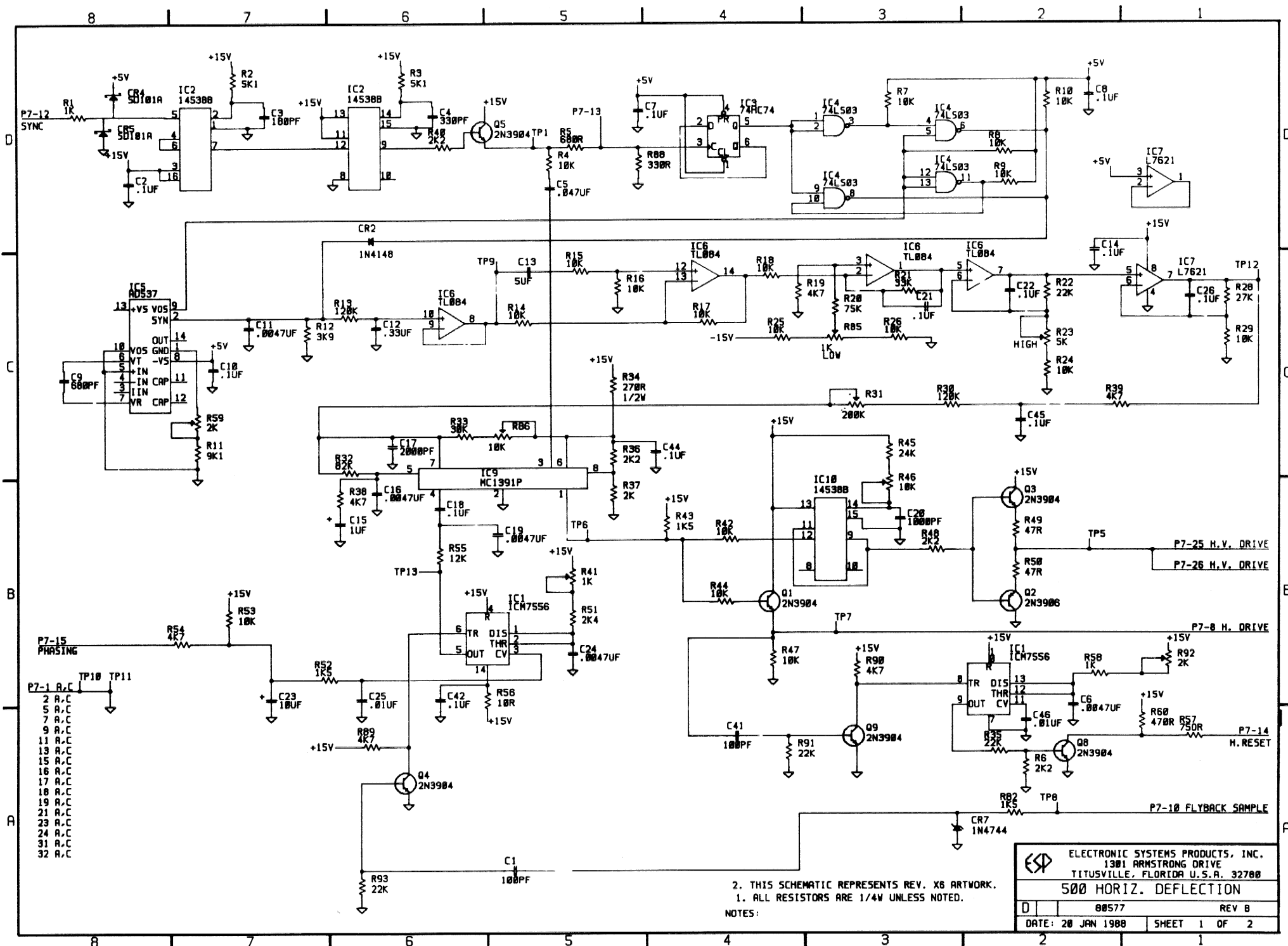

26

B

A

- 2 A.C
- 5 A.C
- 7 A.C
- 9 A.C
- 11 A.C
- 13 A.C
- 15 A.C
- 16 A.C
- 17 A.C
- 18 A.C
- 19 A.C
- 21 A.C
- 23 A.C
- 24 A.C
- 31 A.C
- 32 A.C

2. THIS SCHEMATIC REPRESENTS REV. X8 ARTWORK.  
 1. ALL RESISTORS ARE 1/4W UNLESS NOTED.

NOTES:

 ELECTRONIC SYSTEMS PRODUCTS, INC. 1301 ARMSTRONG DRIVE TITUSVILLE, FLORIDA U.S.A. 32780		500 HORIZ. DEFLECTION	
		00577	REV B
DATE: 20 JAN 1988	SHEET 1 OF 2		

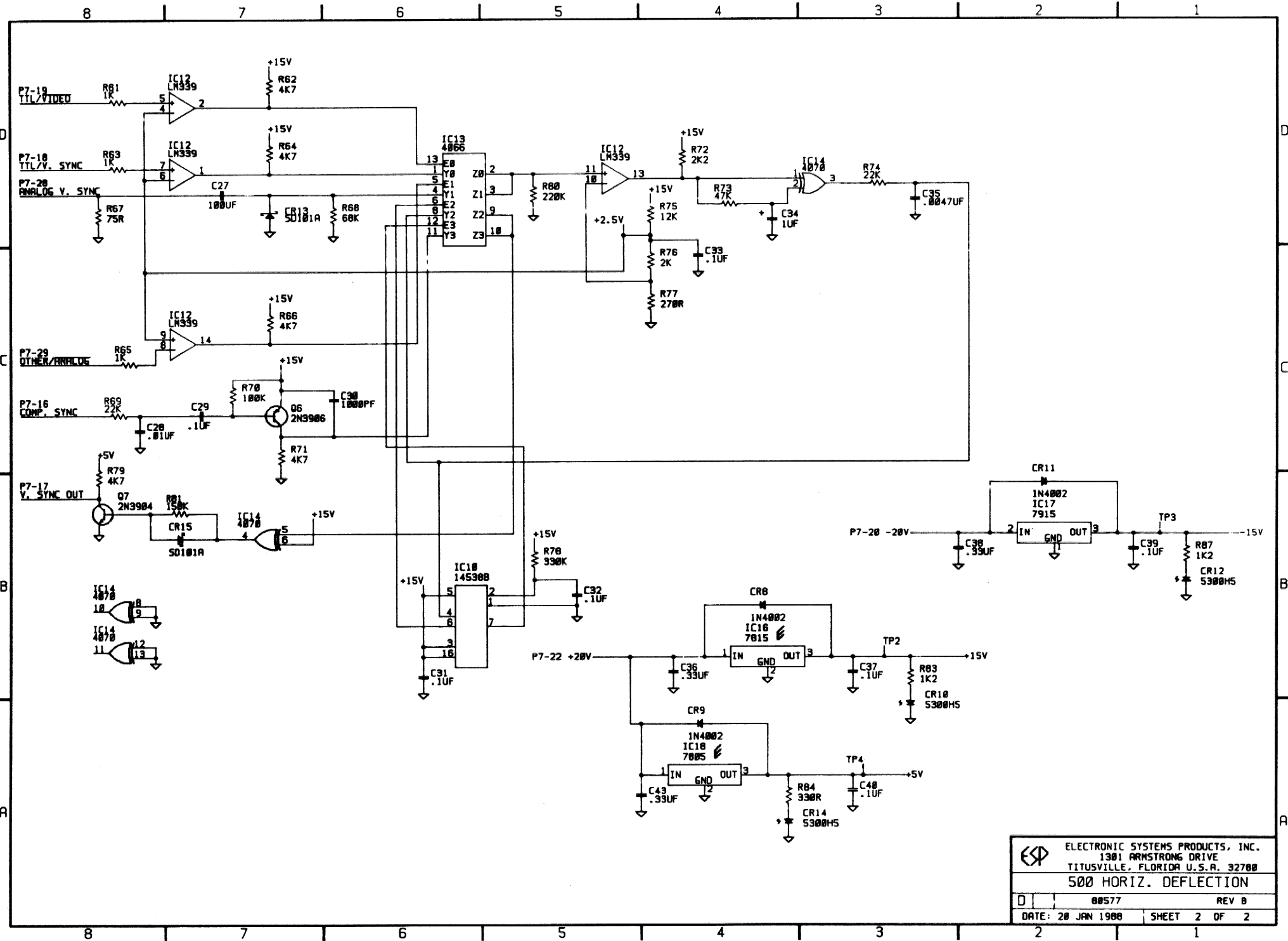

 ELECTRONIC SYSTEMS PRODUCTS, INC.  
 1301 ARMSTRONG DRIVE  
 TITUSVILLE, FLORIDA U.S.A. 32780  
**500 HORIZ. DEFLECTION**  
 08577 REV B  
 DATE: 20 JAN 1988 SHEET 2 OF 2

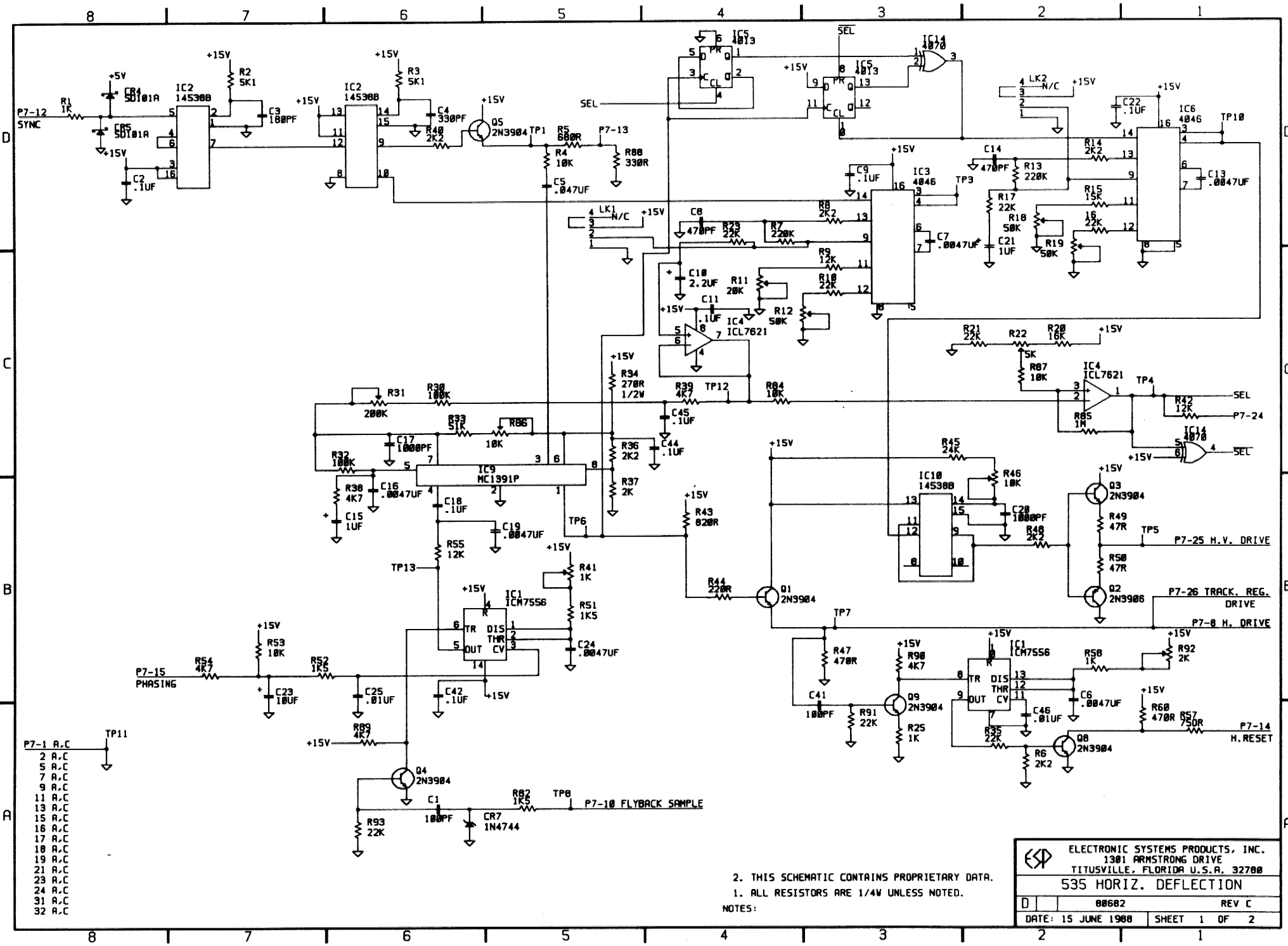

D  
C  
B  
A

**ELECTRONIC SYSTEMS PRODUCTS, INC.**  
 1301 ARMSTRONG DRIVE  
 TITUSVILLE, FLORIDA U.S.A. 32780  
**535 HORIZ. DEFLECTION**  
 D 80602 REV C  
 DATE: 15 JUNE 1988 SHEET 1 OF 2

2. THIS SCHEMATIC CONTAINS PROPRIETARY DATA.  
 1. ALL RESISTORS ARE 1/4W UNLESS NOTED.  
 NOTES:





HORIZONTAL DEFLECTION  
MODULE

(H)	INDICATES HORIZ. RATE
(V)	INDICATES VERT. RATE
←	INDICATES INPUT
→	INDICATES OUTPUT
●	INDICATES CONNECTION POINT

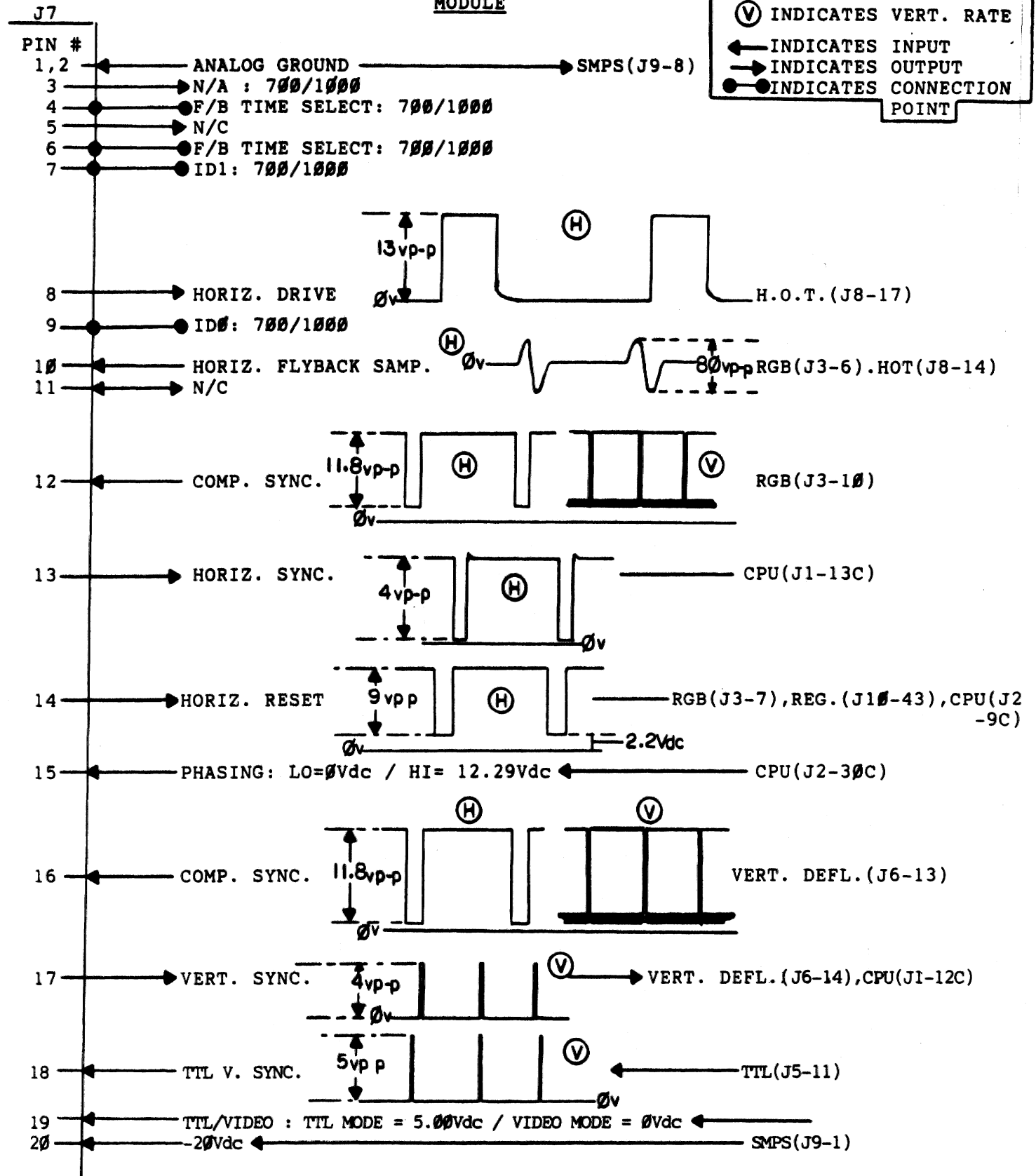

HORIZONTAL DEFLECTION  
MODULE

(H)	INDICATES HORIZ. RATES
(V)	INDICATES VERT. RATES
←	INDICATES INPUT
→	INDICATES OUTPUT
●	INDICATES CONNECTION POINT

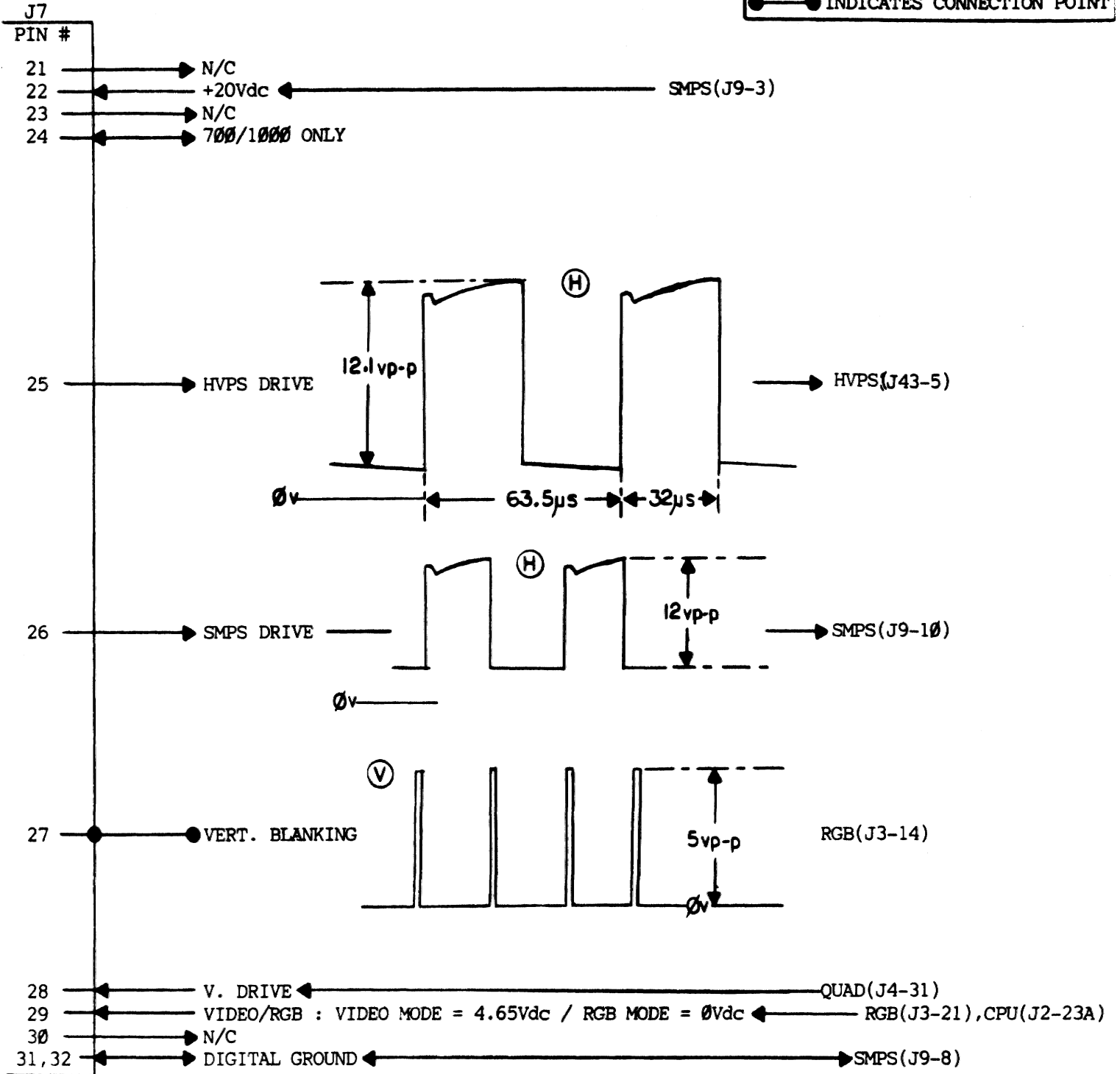

\*\*\* TTL SOURCE: B&K GENERATOR MODEL# 1249

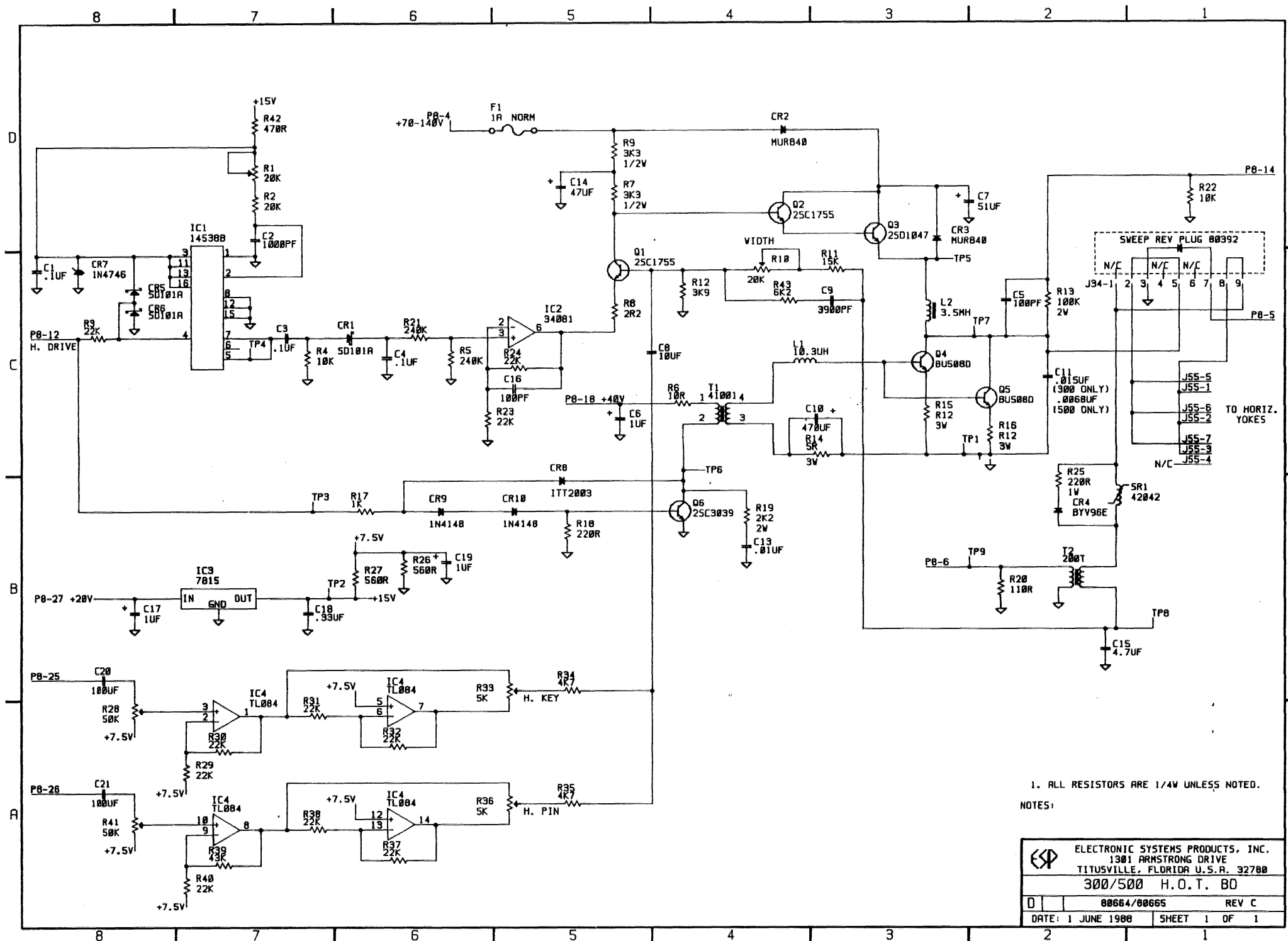

1. ALL RESISTORS ARE 1/4W UNLESS NOTED.  
 NOTES:

 ELECTRONIC SYSTEMS PRODUCTS, INC. 1301 ARMSTRONG DRIVE TITUSVILLE, FLORIDA U.S.A. 32780		
		300/500 H.O.T. 80
D	00664/00665	REV C
DATE: 1 JUNE 1988		SHEET 1 OF 1

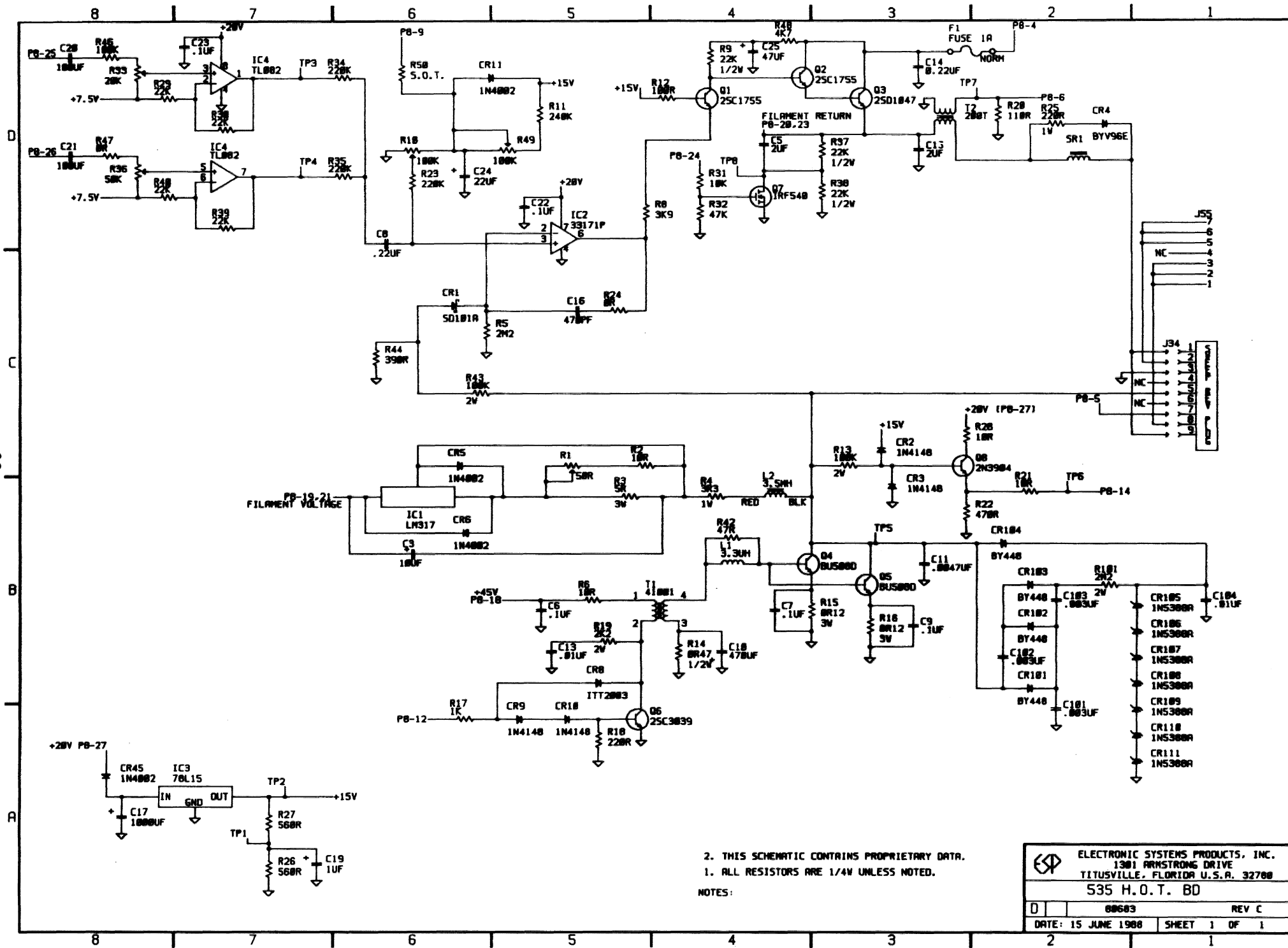

2. THIS SCHEMATIC CONTAINS PROPRIETARY DATA.  
 1. ALL RESISTORS ARE 1/4W UNLESS NOTED.

NOTES:

 ELECTRONIC SYSTEMS PRODUCTS, INC. 1301 ARMSTRONG DRIVE TITUSVILLE, FLORIDA U.S.A. 32708		
		535 H.O.T. BD
D	60603	REV C
DATE: 15 JUNE 1988	SHEET 1 OF 1	

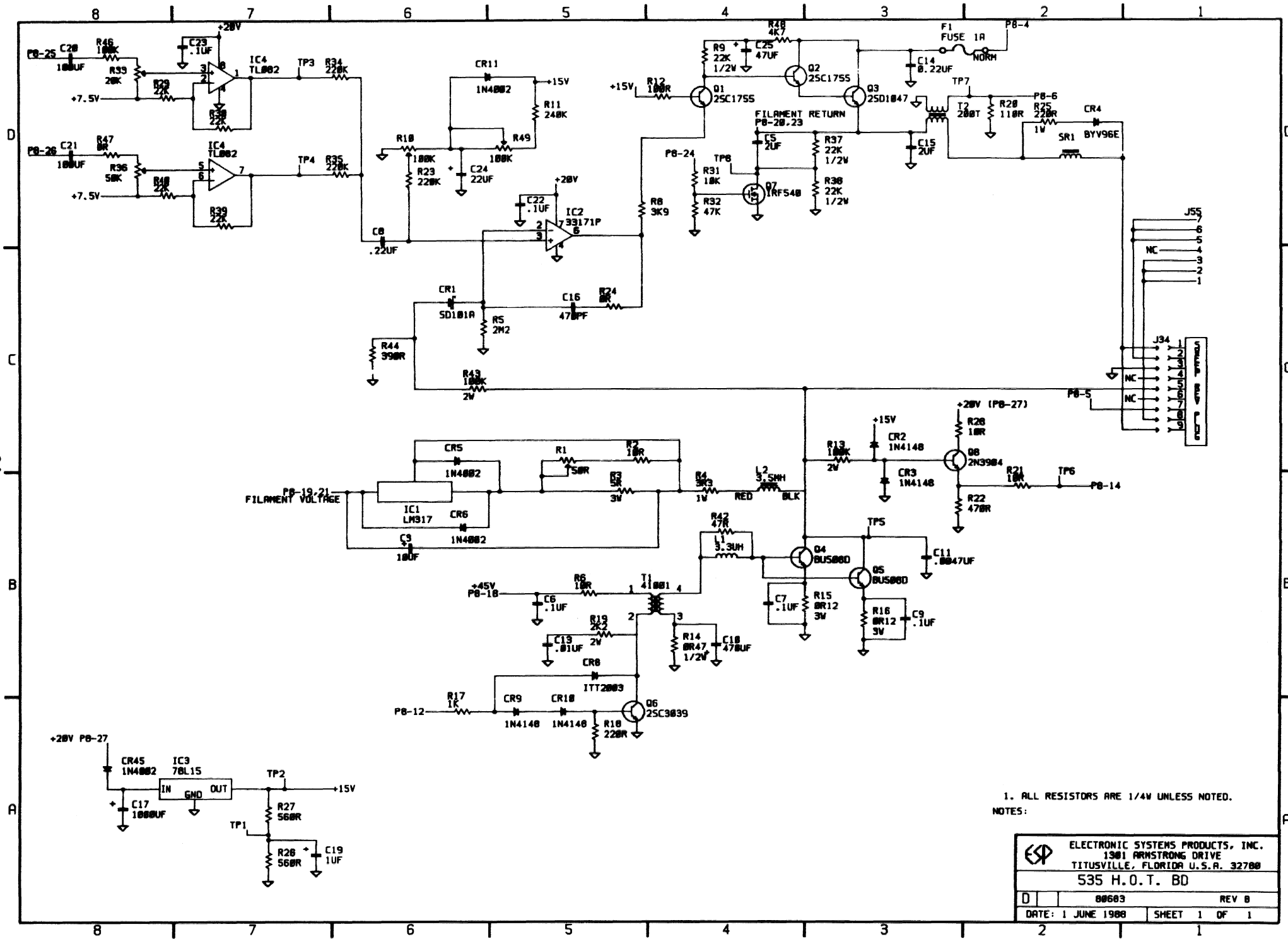

1. ALL RESISTORS ARE 1/4W UNLESS NOTED.  
 NOTES:

 ELECTRONIC SYSTEMS PRODUCTS, INC. 1301 ARMSTRONG DRIVE TITUSVILLE, FLORIDA U.S.A. 32780		
535 H.O.T. BD		
D	88683	REV B
DATE: 1 JUNE 1988	SHEET 1 OF 1	

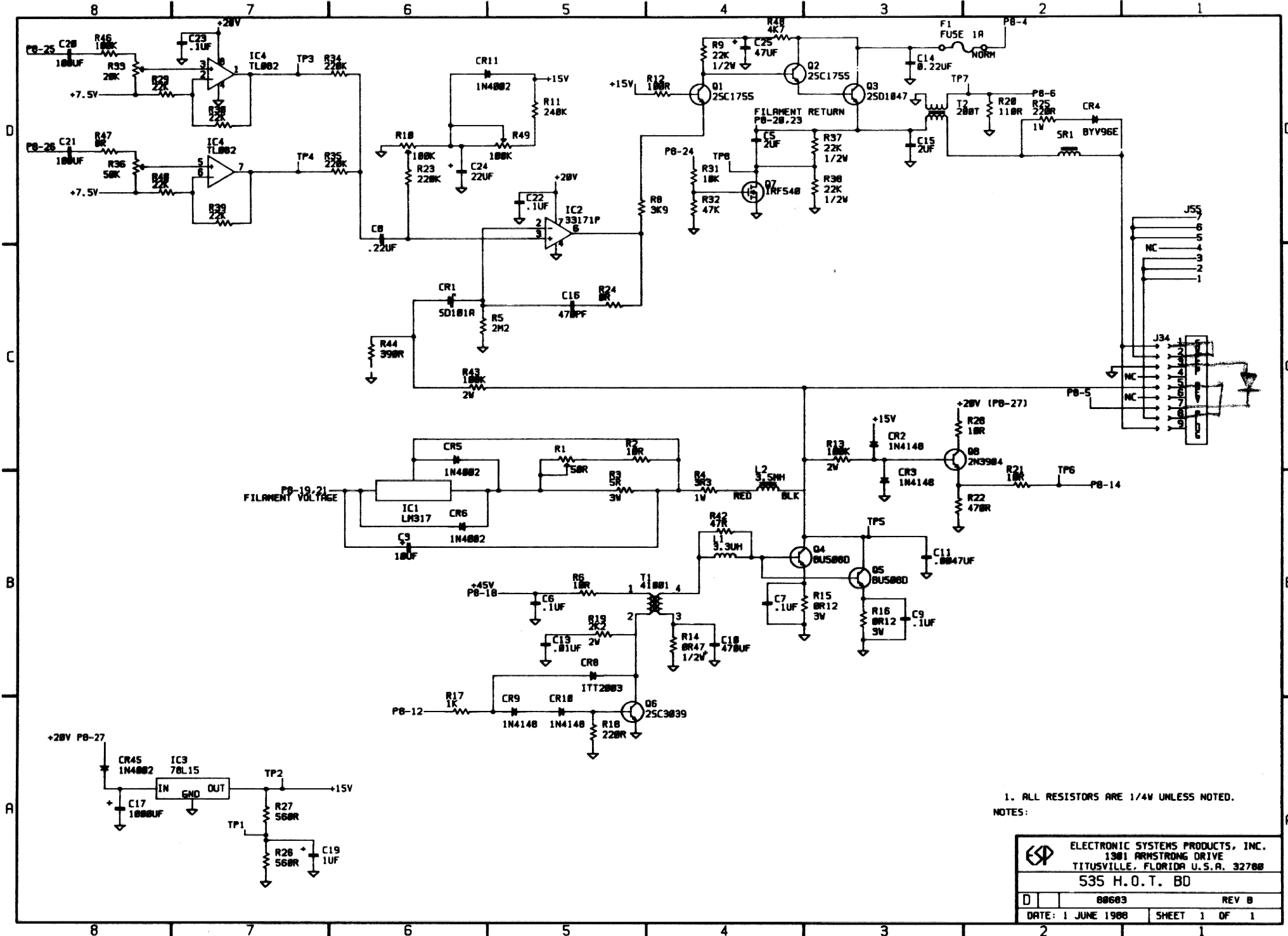

1. ALL RESISTORS ARE 1/4W UNLESS NOTED.  
 NOTES:

 ELECTRONIC SYSTEMS PRODUCTS, INC. 1301 ARMSTRONG DRIVE TITUSVILLE, FLORIDA U.S.A. 32780			
		535 H.O.T. BD	
<input type="checkbox"/>	80603	REV B	
DATE: 1 JUNE 1988	SHEET 1 OF 1		

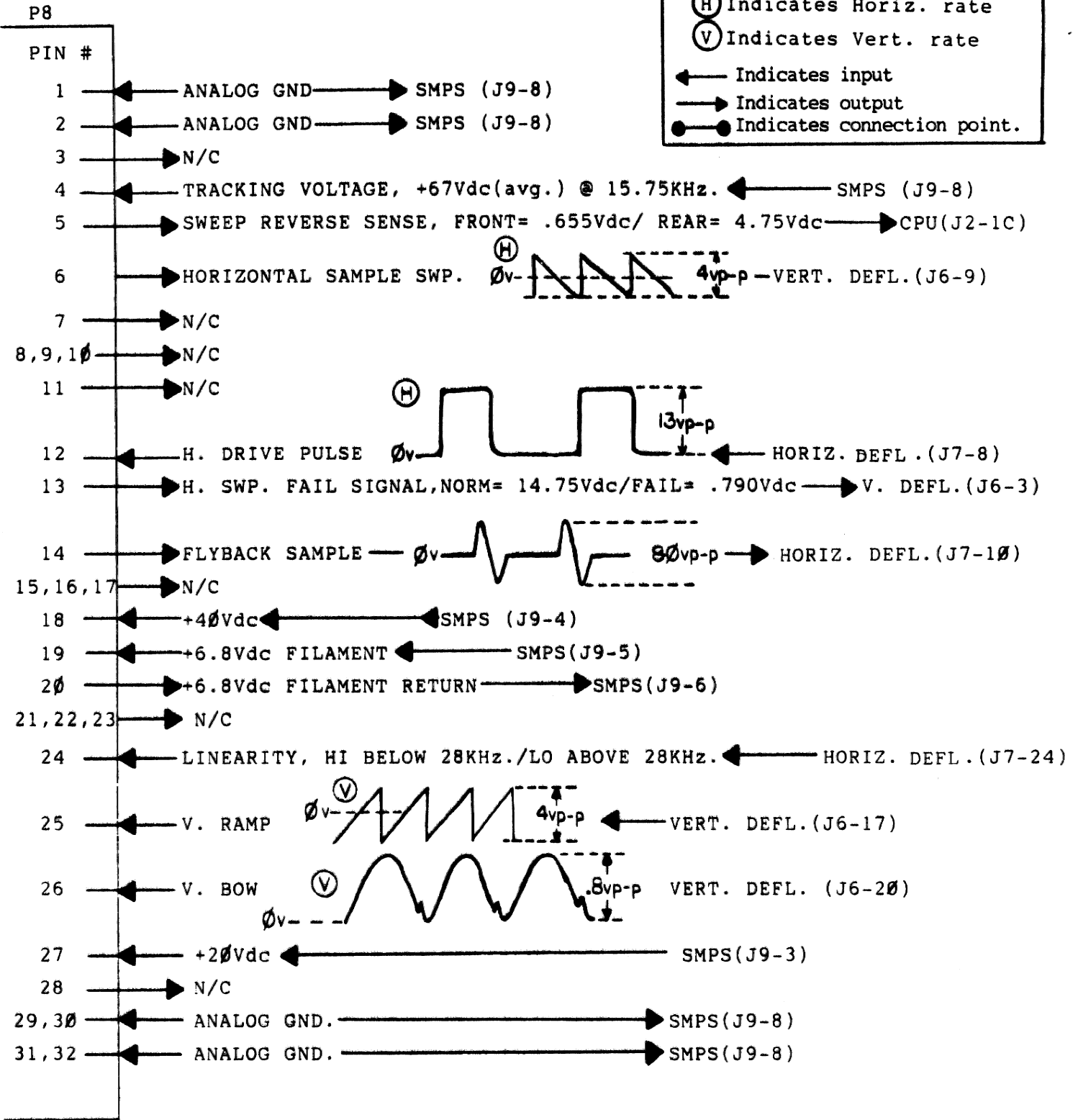



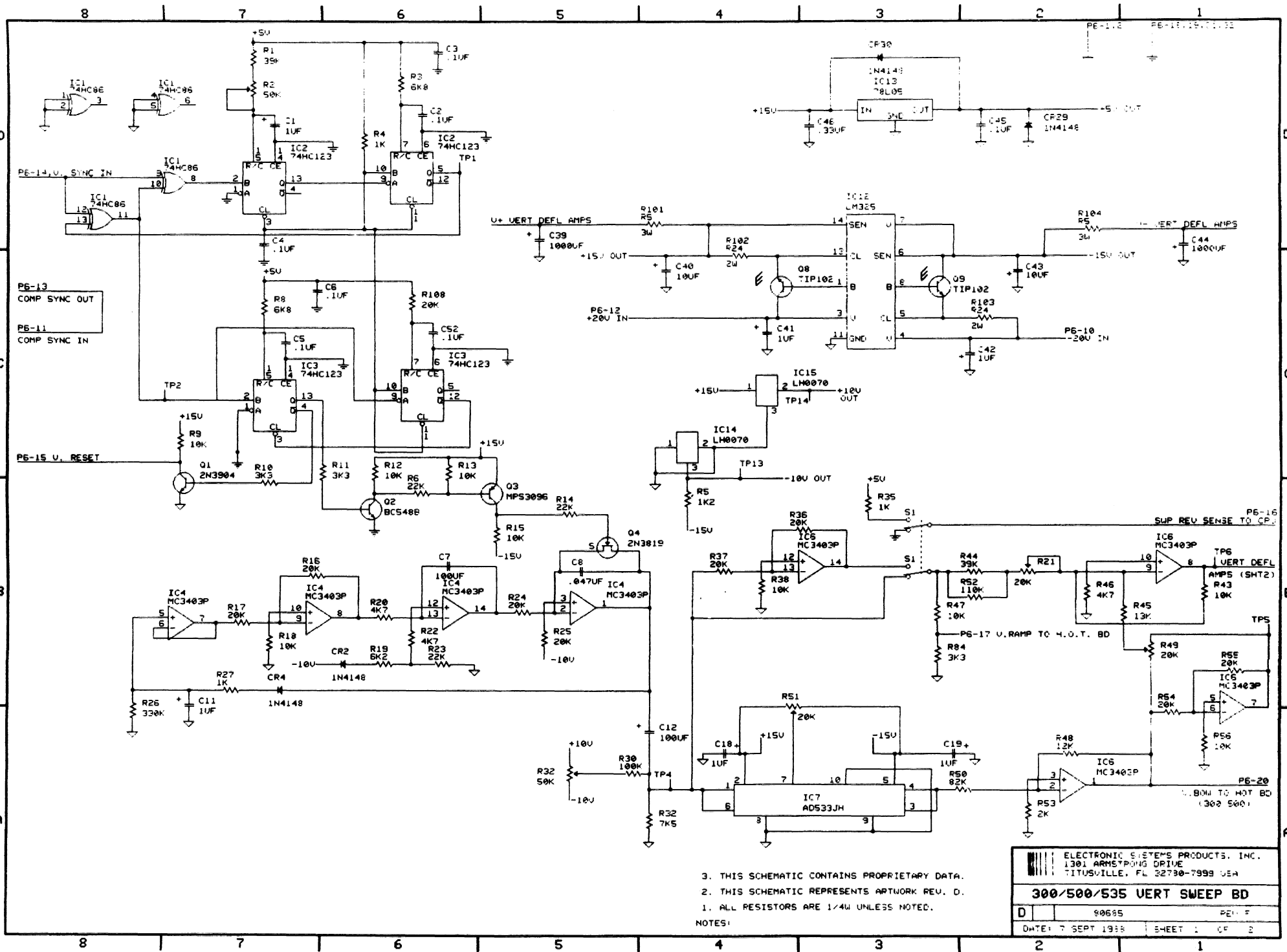



3. THIS SCHEMATIC CONTAINS PROPRIETARY DATA.  
 2. THIS SCHEMATIC REPRESENTS ARTWORK REV. D.  
 1. ALL RESISTORS ARE 1/4W UNLESS NOTED.

NOTES:

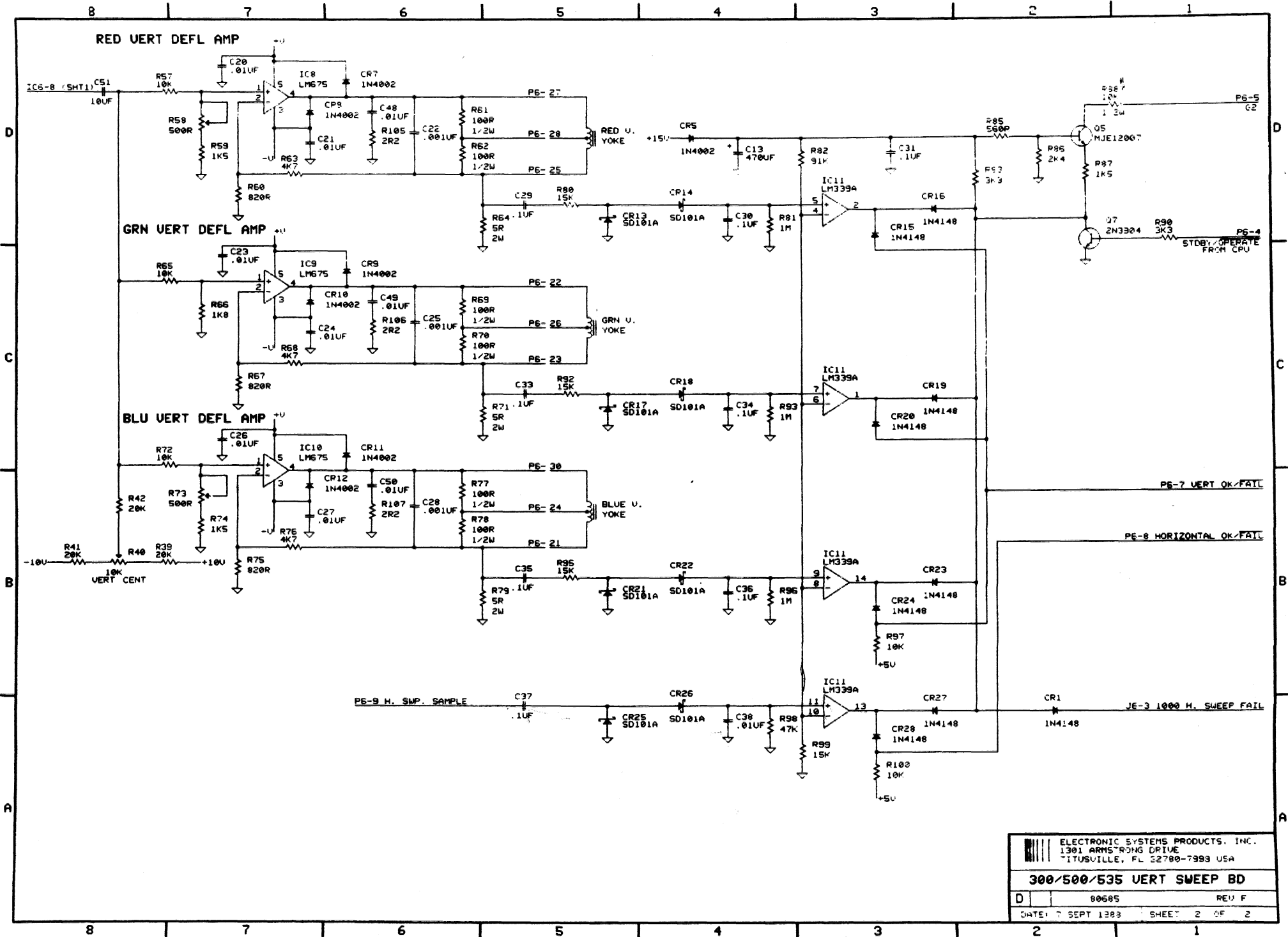
ELECTRONIC SYSTEMS PRODUCTS, INC. 1301 ARMSTRONG DRIVE TITUSVILLE, FL 32780-7999 USA	
<b>300/500/535 VERT SWEEP BD</b>	
D	90655
DATE: 7 SEPT 1988	SHEET 1 OF 2



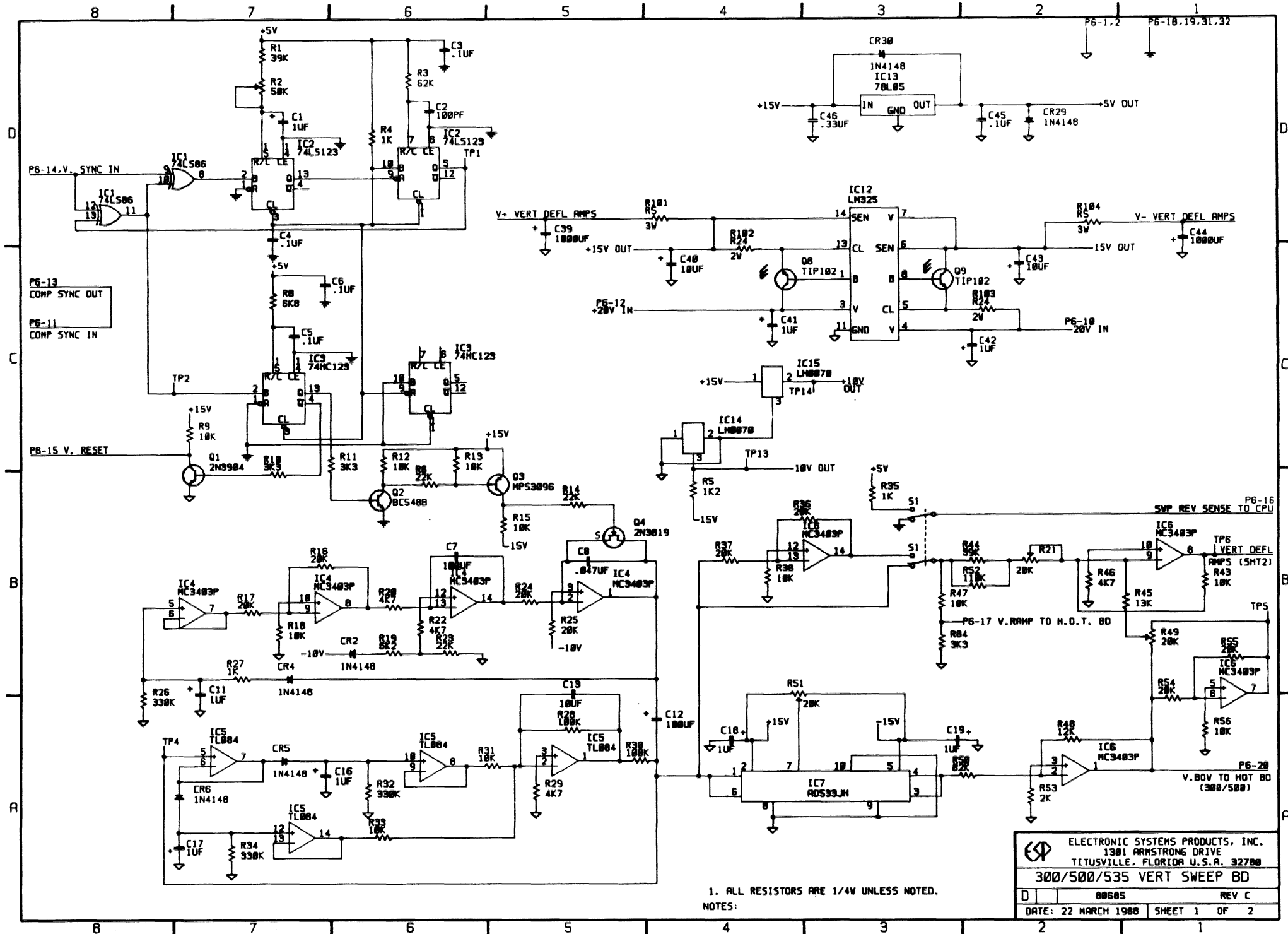

**ELECTRONIC SYSTEMS PRODUCTS, INC.**  
 1301 ARMSTRONG DRIVE  
 TITUSVILLE, FL 32780-7993 USA  
**300/500/535 VERT SWEEP BD**  
 D 80685 REV F  
 DATE: 7 SEPT 1988 SHEET 2 OF 2

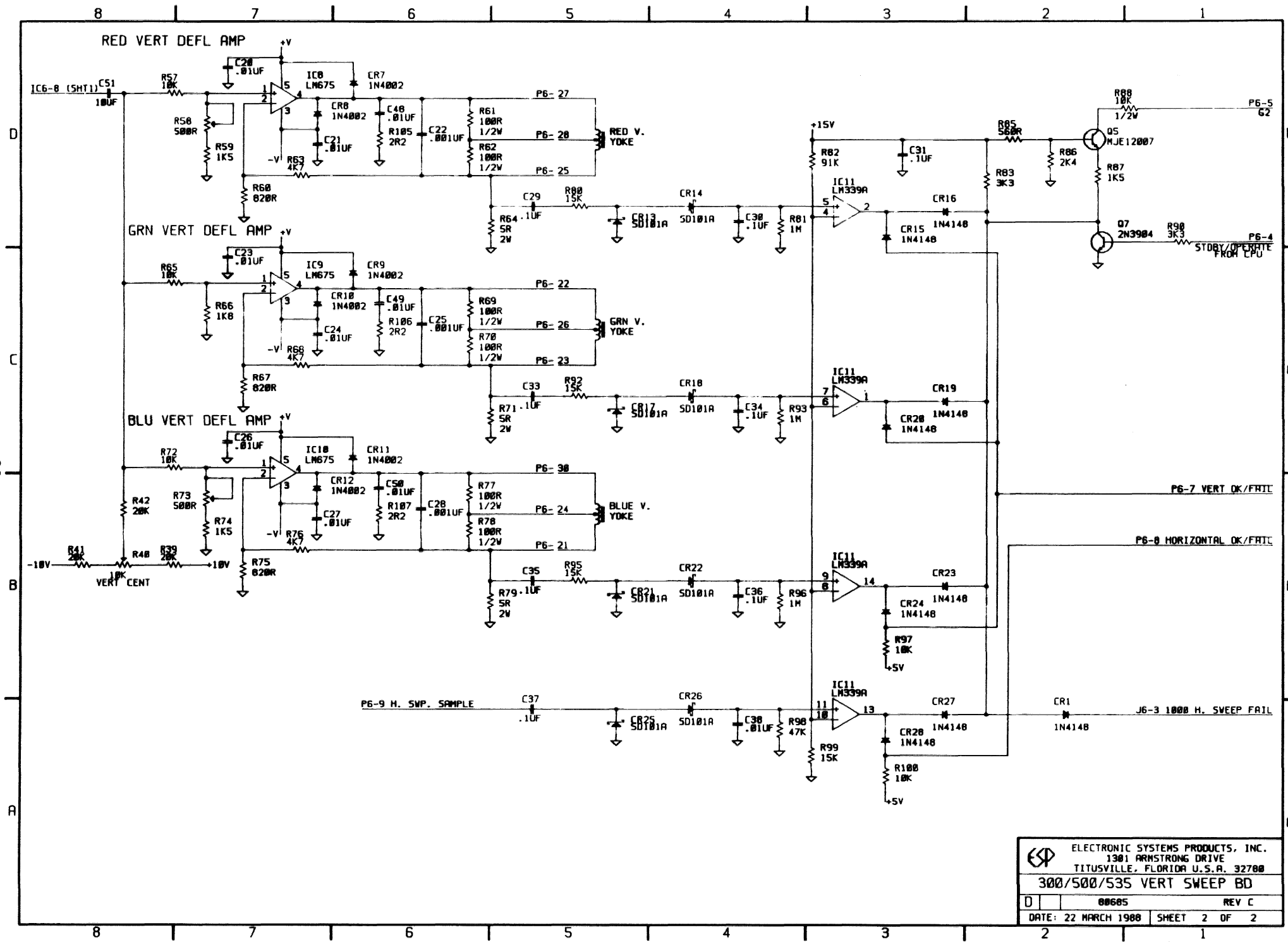

1. ALL RESISTORS ARE 1/4W UNLESS NOTED.  
 NOTES:

 ELECTRONIC SYSTEMS PRODUCTS, INC. 1301 ARMSTRONG DRIVE TITUSVILLE, FLORIDA U.S.A. 32780		
		<b>300/500/535 VERT SWEEP BD</b>
D	88605	REV C
DATE: 22 MARCH 1988	SHEET 1	OF 2



ESP		ELECTRONIC SYSTEMS PRODUCTS, INC.	
		1301 ARMSTRONG DRIVE	
		TITUSVILLE, FLORIDA U.S.A. 32780	
300/500/535 VERT SWEEP BD			
0	80605	REV C	
DATE: 22 MARCH 1988		SHEET 2 OF 2	

J6

(H) Indicates Horiz. Rate  
 (V) Indicates Vert. Rate  
 ← Indicates input  
 → Indicates output  
 ●—● Indicates connection point.

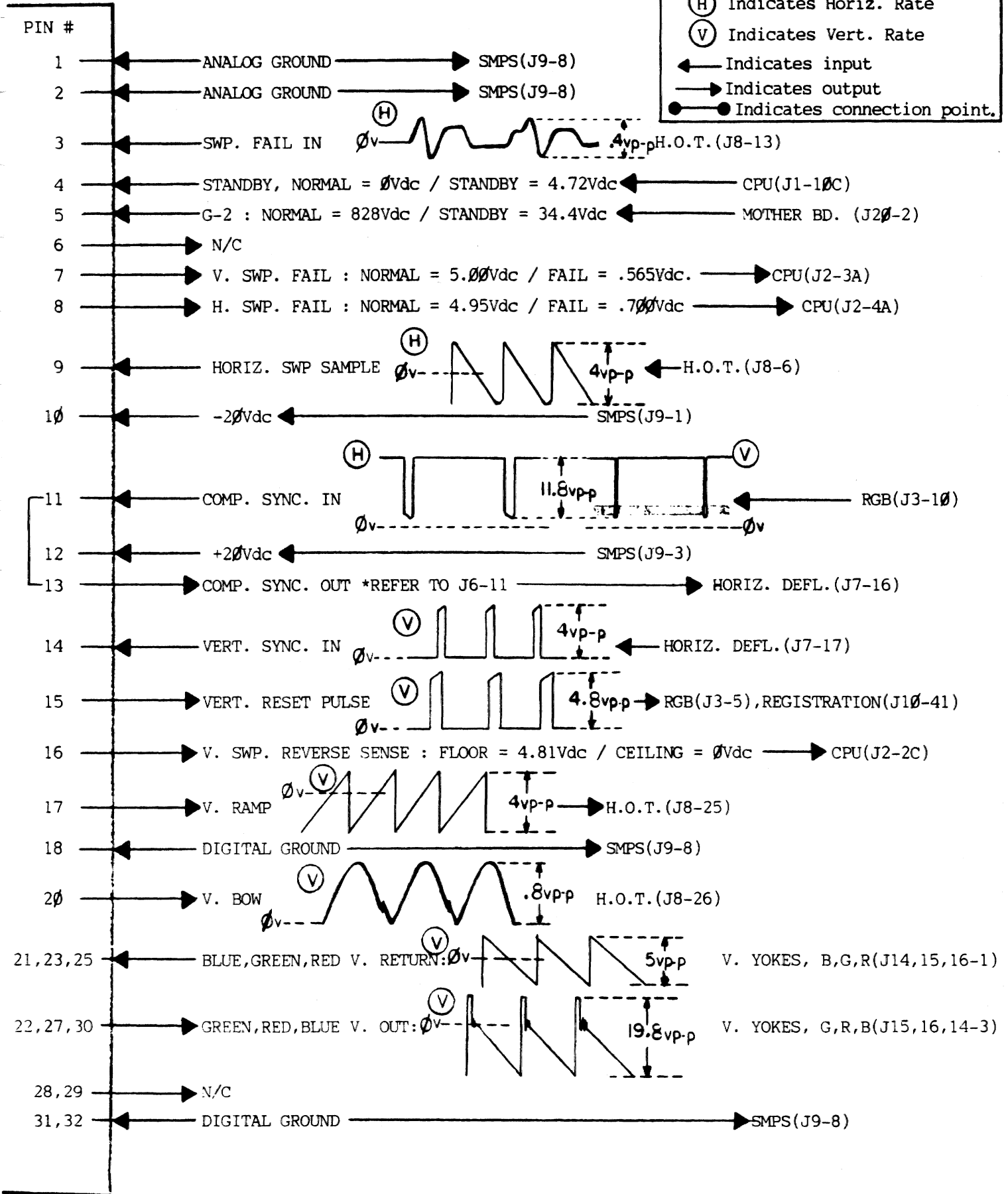

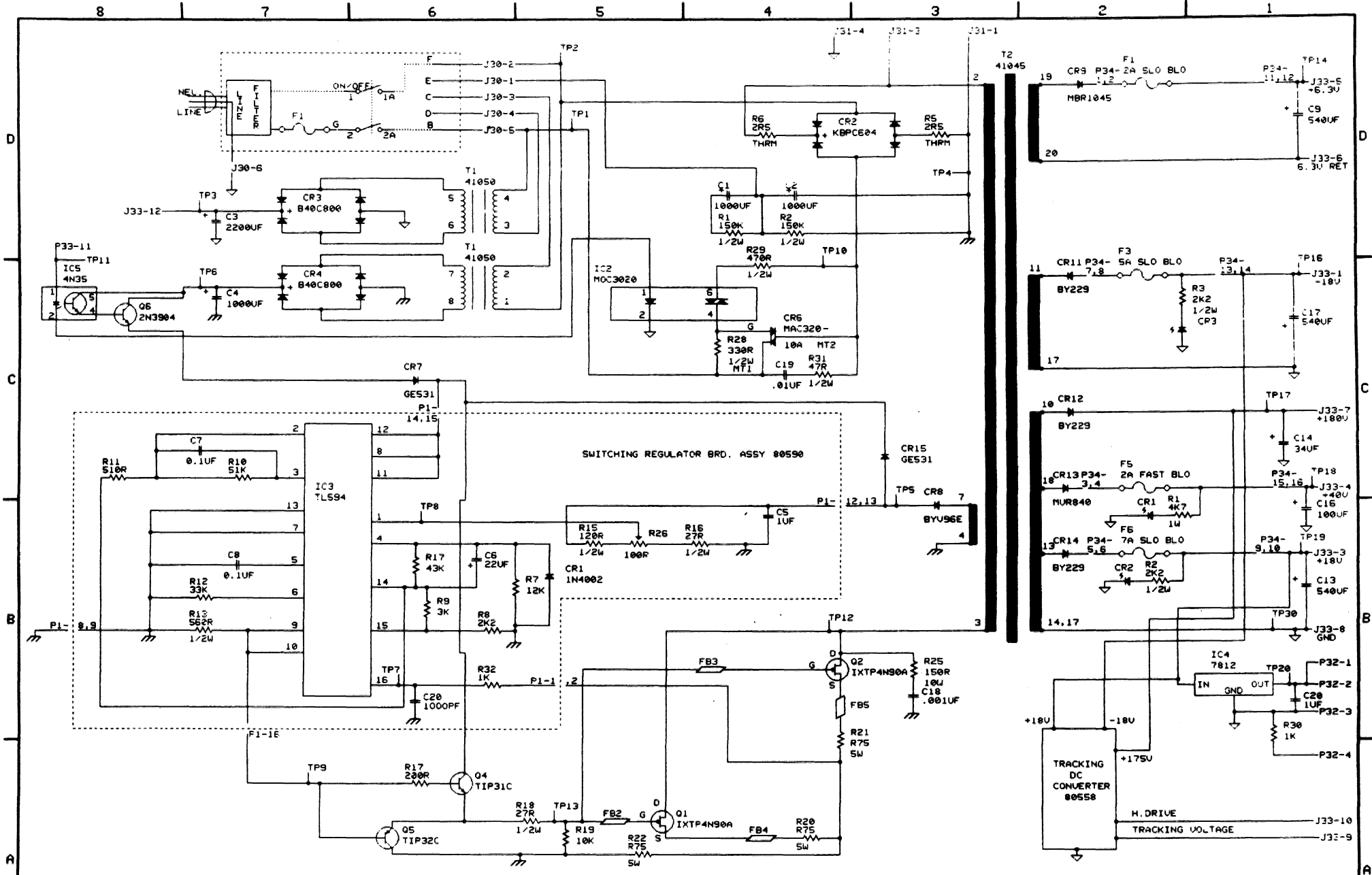

2. THIS SCHEMATIC CONTAINS PROPRIETARY DATA.

1. ALL RESISTORS ARE 1/4W UNLESS NOTED.

NOTES:

 ELECTRONIC SYSTEMS PRODUCTS, INC. 1301 ARMSTRONG DRIVE TITUSVILLE, FL 32780-7999 USA		
<b>300/500/535 SMPS</b>		
D	M80E75	REV E
DATE: 12 AUG 1983	SHEET 1 OF 1	

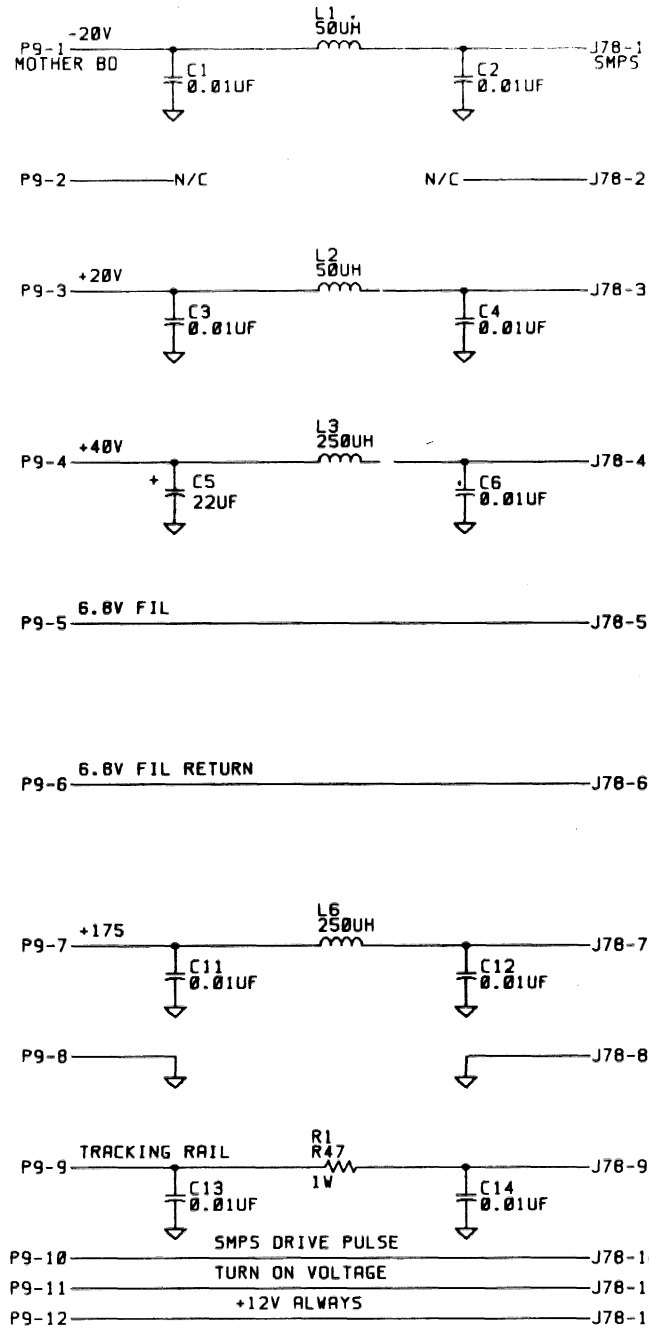

ESP	ELECTRONIC SYSTEMS PRODUCTS, INC.	
	1301 ARMSTRONG DRIVE TITUSVILLE, FLORIDA U.S.A. 32780	
SMPS FILTER BD		
D	80694	REV A
DATE:	24 JULY 1988	SHEET 1 OF 1

J33 SMPS TO J9 MOTHER BOARD

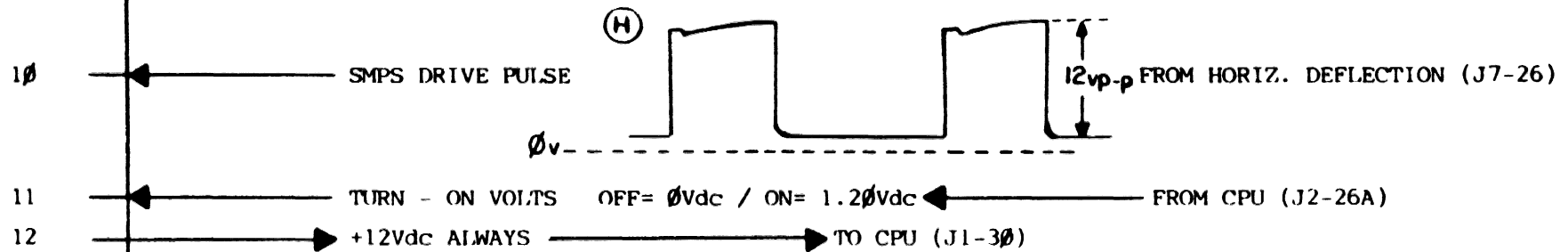
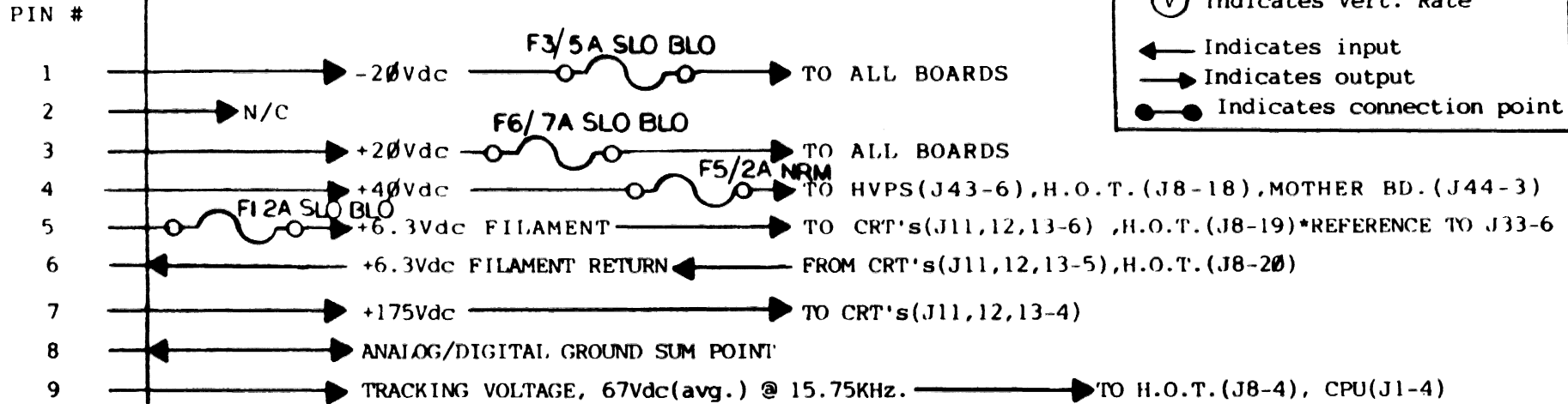
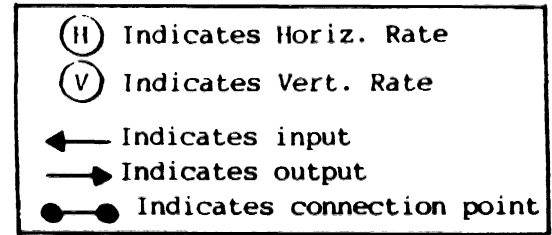

43



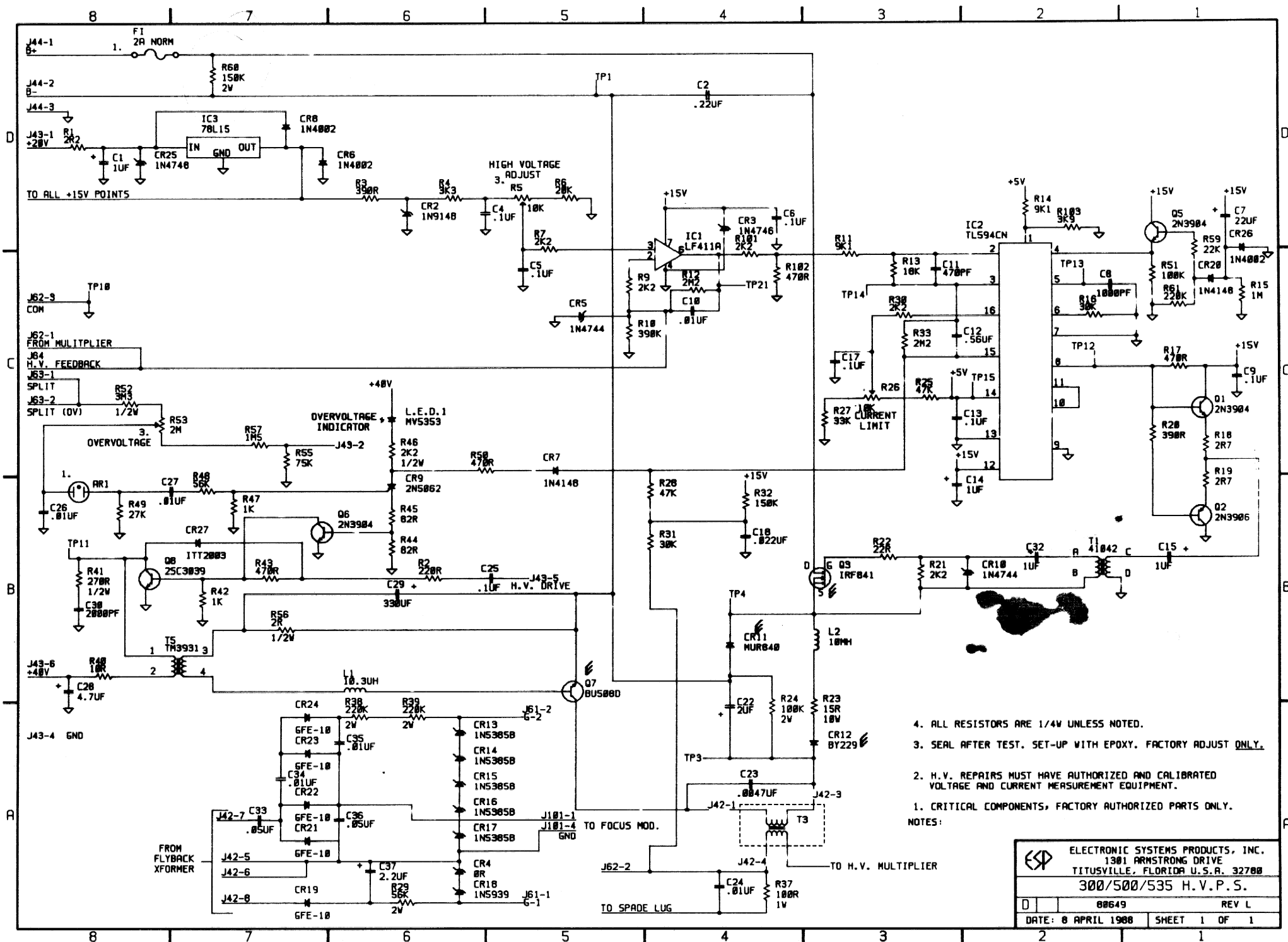

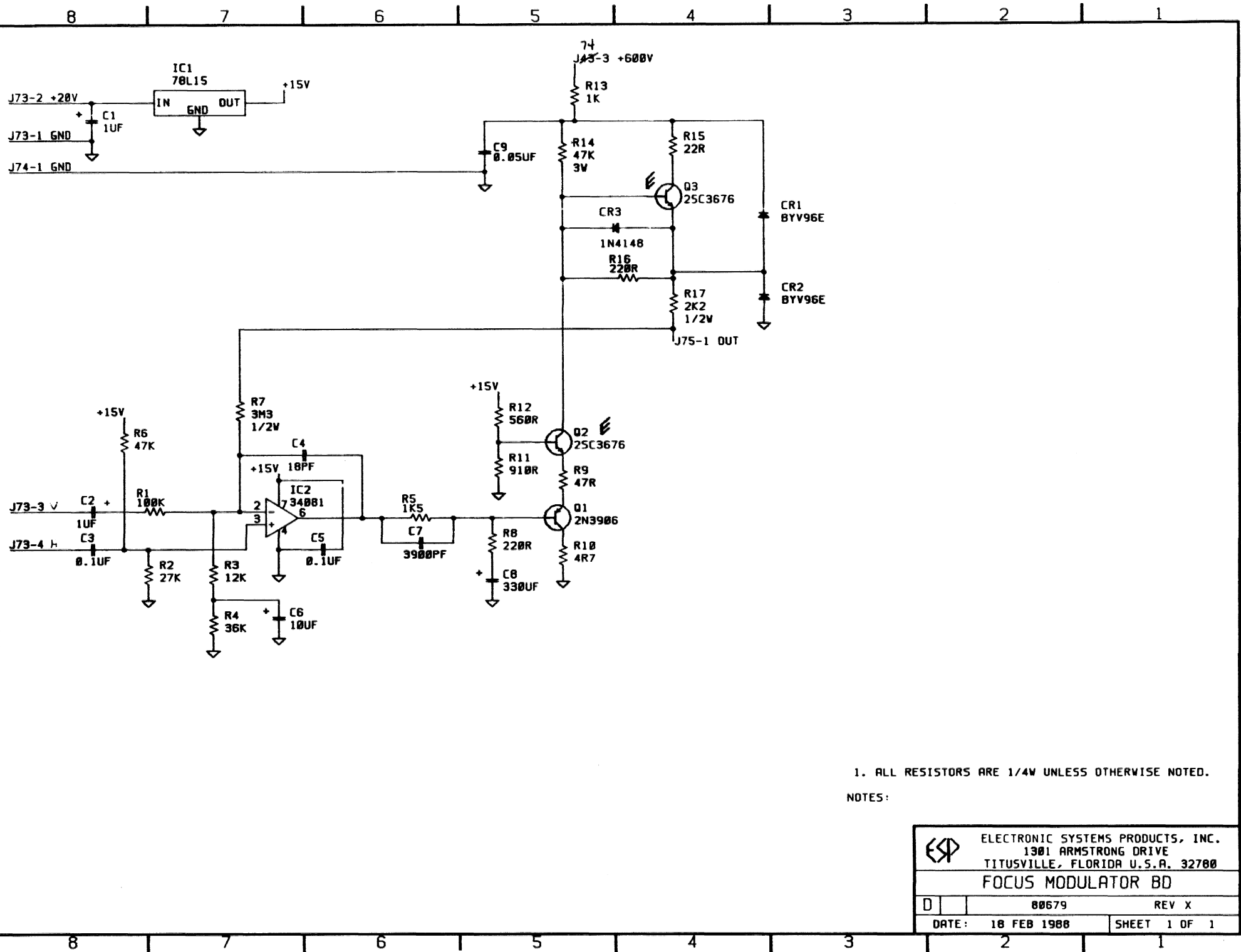

4. ALL RESISTORS ARE 1/4W UNLESS NOTED.
3. SEAL AFTER TEST. SET-UP WITH EPOXY. FACTORY ADJUST ONLY.
2. H.V. REPAIRS MUST HAVE AUTHORIZED AND CALIBRATED VOLTAGE AND CURRENT MEASUREMENT EQUIPMENT.
1. CRITICAL COMPONENTS; FACTORY AUTHORIZED PARTS ONLY.
- NOTES:

 ELECTRONIC SYSTEMS PRODUCTS, INC. 1301 ARMSTRONG DRIVE TITUSVILLE, FLORIDA U.S.A. 32708		
		300/500/535 H.V.P.S.
D	00649	REV L
DATE: 8 APRIL 1988	SHEET 1	OF 1

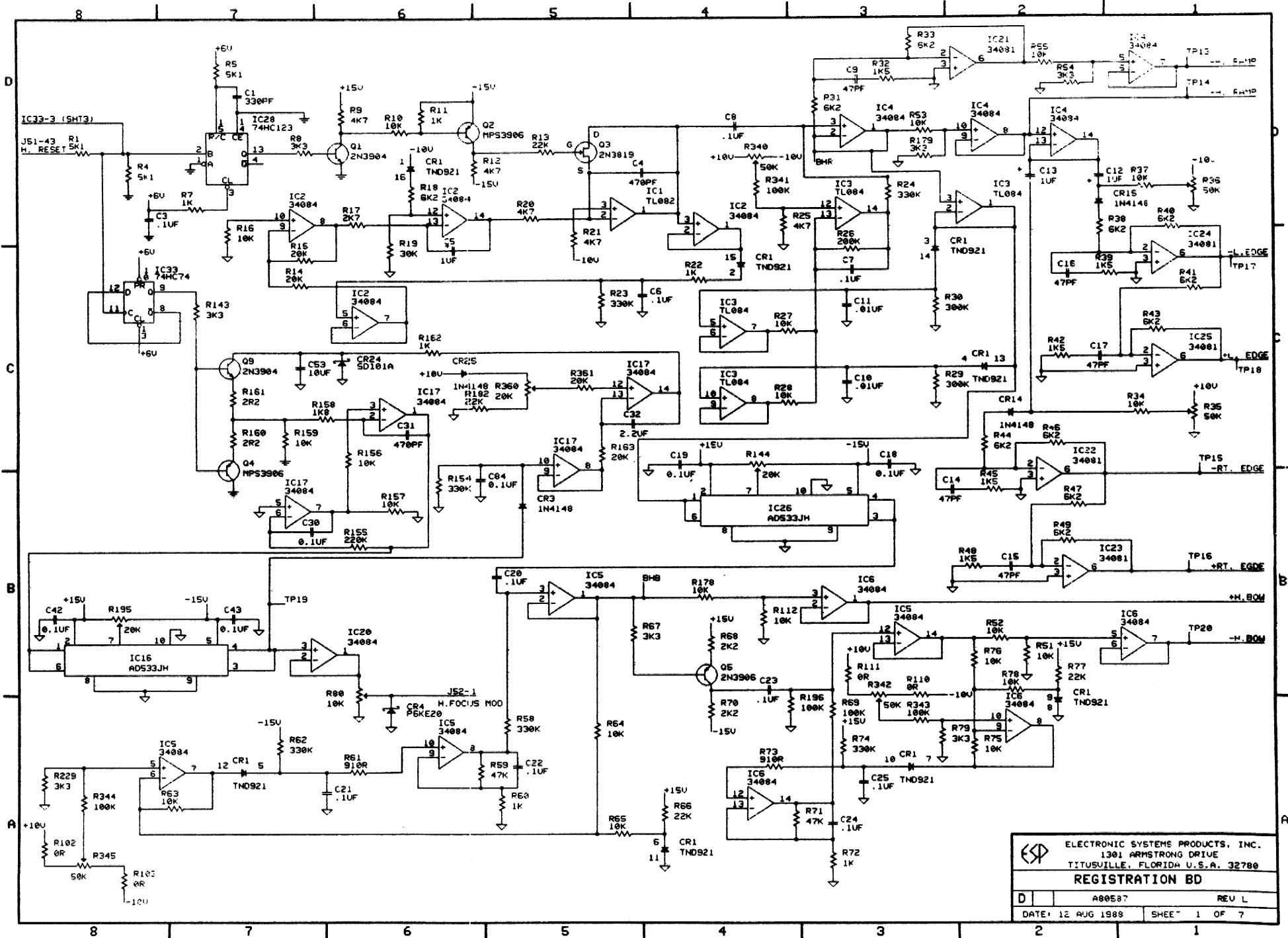



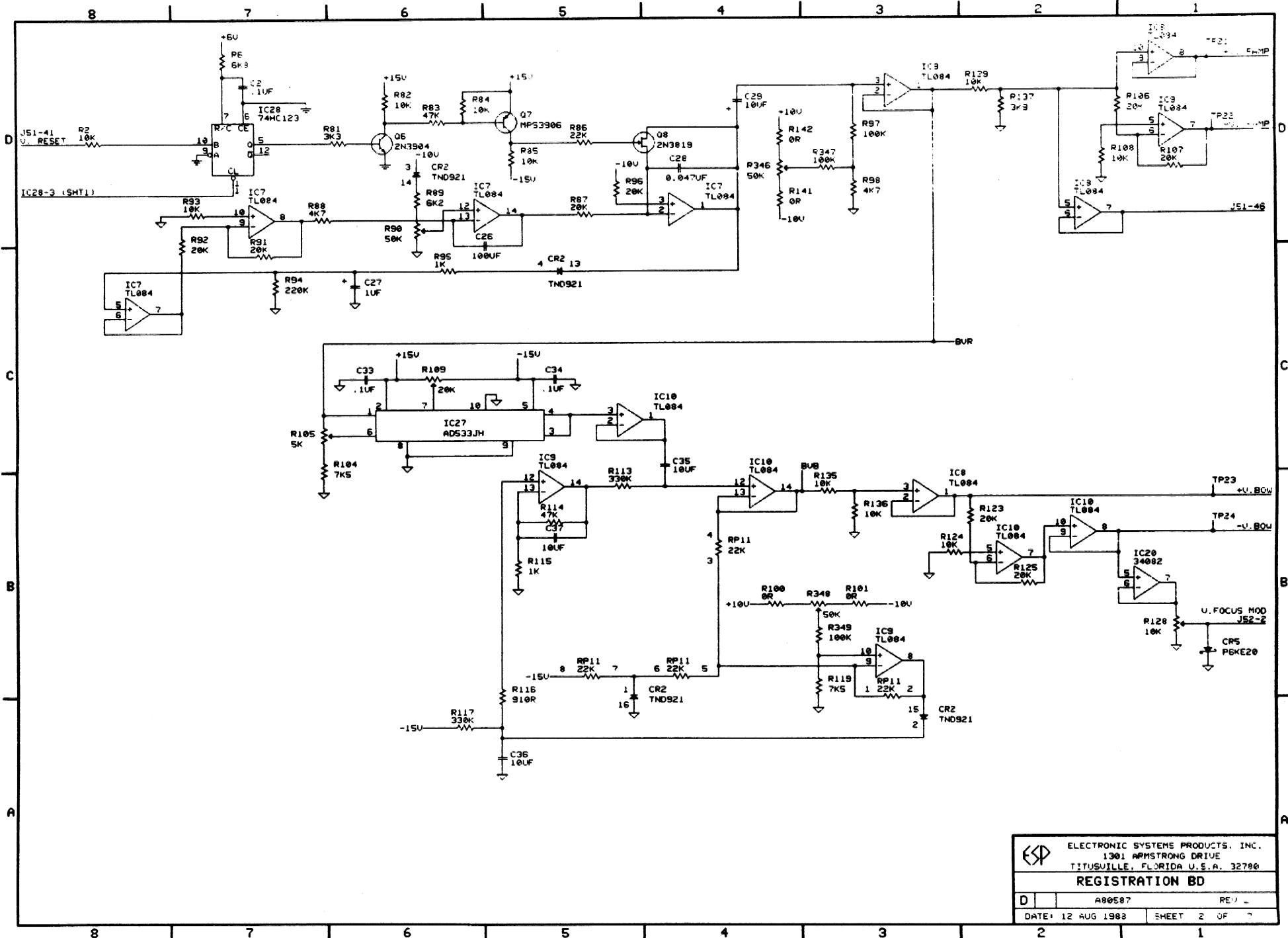

**ELECTRONIC SYSTEMS PRODUCTS, INC.**  
 1301 ARMSTRONG DRIVE  
 TITUSVILLE, FLORIDA U.S.A. 32780  
**REGISTRATION BD**  
 D      A80587      REV L  
 DATE: 12 AUG 1988      SHEET 1 OF 7

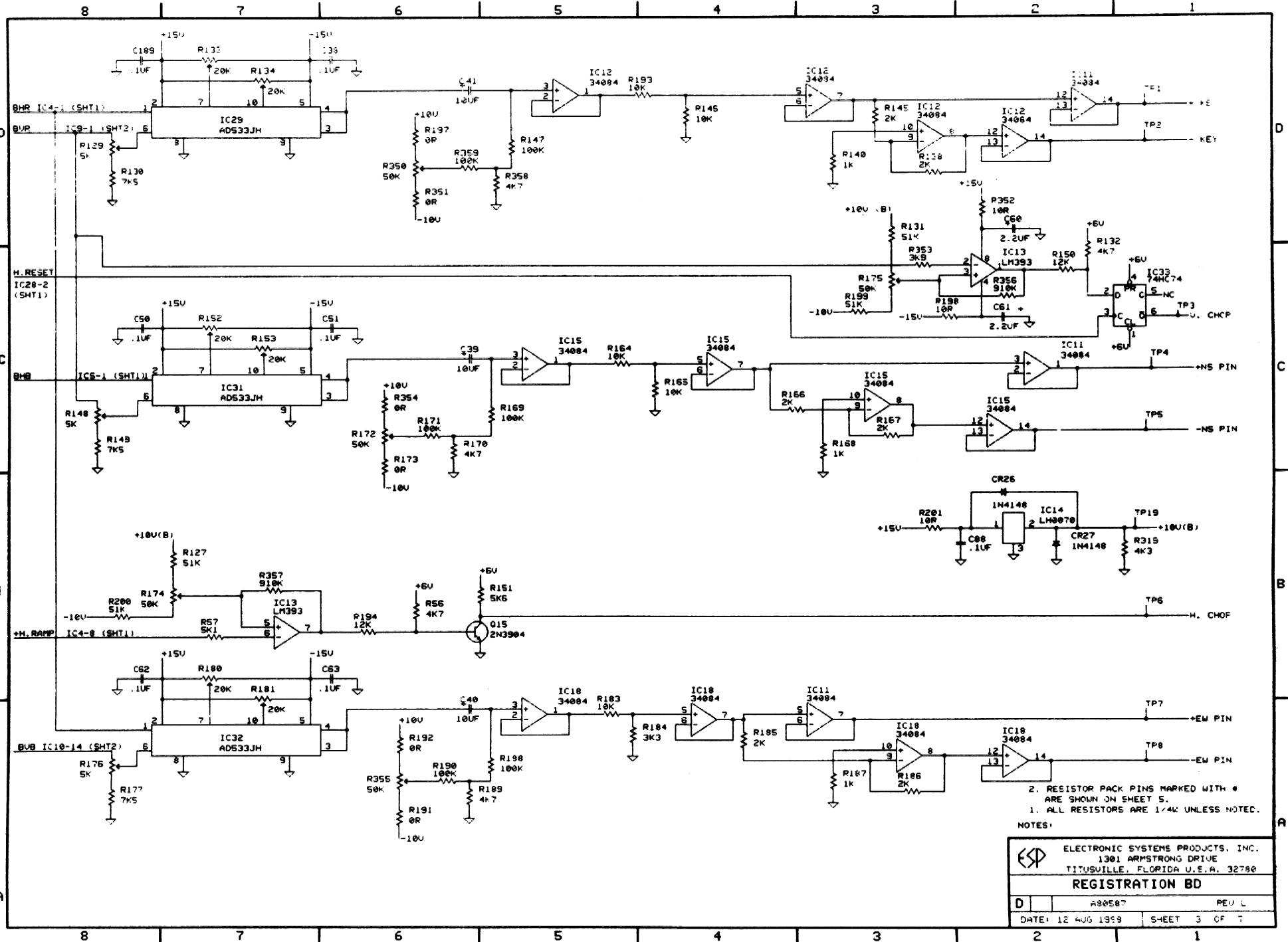

47

 ELECTRONIC SYSTEMS PRODUCTS, INC. 1301 ARMSTRONG DRIVE TITUSVILLE, FLORIDA U.S.A. 32780			
		<b>REGISTRATION BD</b>	
D	A80587	REV	
DATE: 12 AUG 1983		SHEET 2 OF 7	



NOTES:  
 2. RESISTOR PACK PINS MARKED WITH \* ARE SHOWN ON SHEET 5.  
 1. ALL RESISTORS ARE 1/4W UNLESS NOTED.

 ELECTRONIC SYSTEMS PRODUCTS, INC. 1301 ARMSTRONG DRIVE TITUSVILLE, FLORIDA U.S.A. 32780		
<b>REGISTRATION BD</b>		
D	A90587	PEU L
DATE: 12 JUN 1993	SHEET 3 OF 7	

49

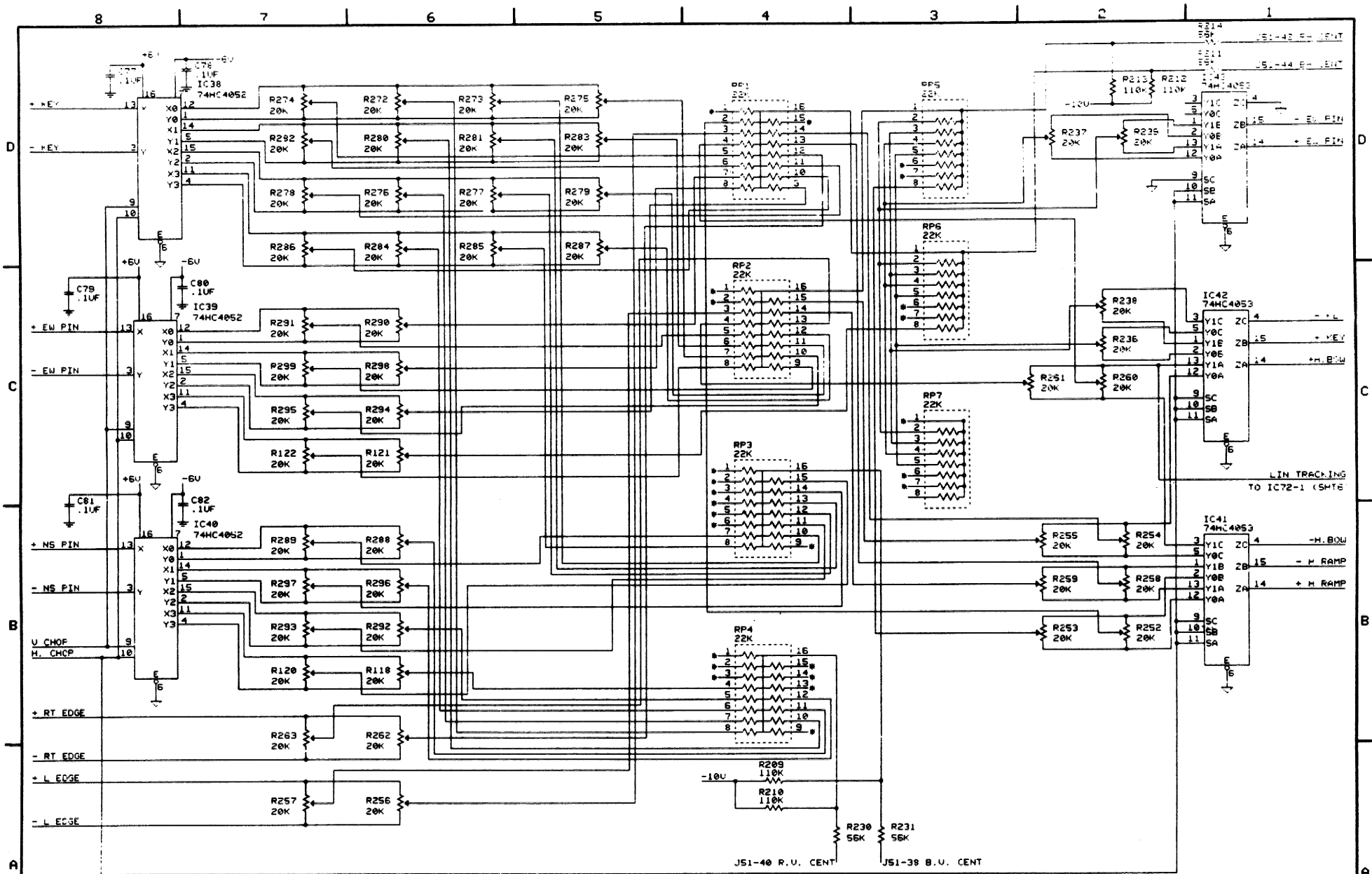



 ELECTRONIC SYSTEMS PRODUCTS, INC.  
 1301 ARMSTRONGS DRIVE  
 TITUSVILLE, FLORIDA U.S.A. 32780

**REGISTRATION BD**

D	880597	PEL L
DATE: 12 AUG 1988	SHEET 4 OF 7	

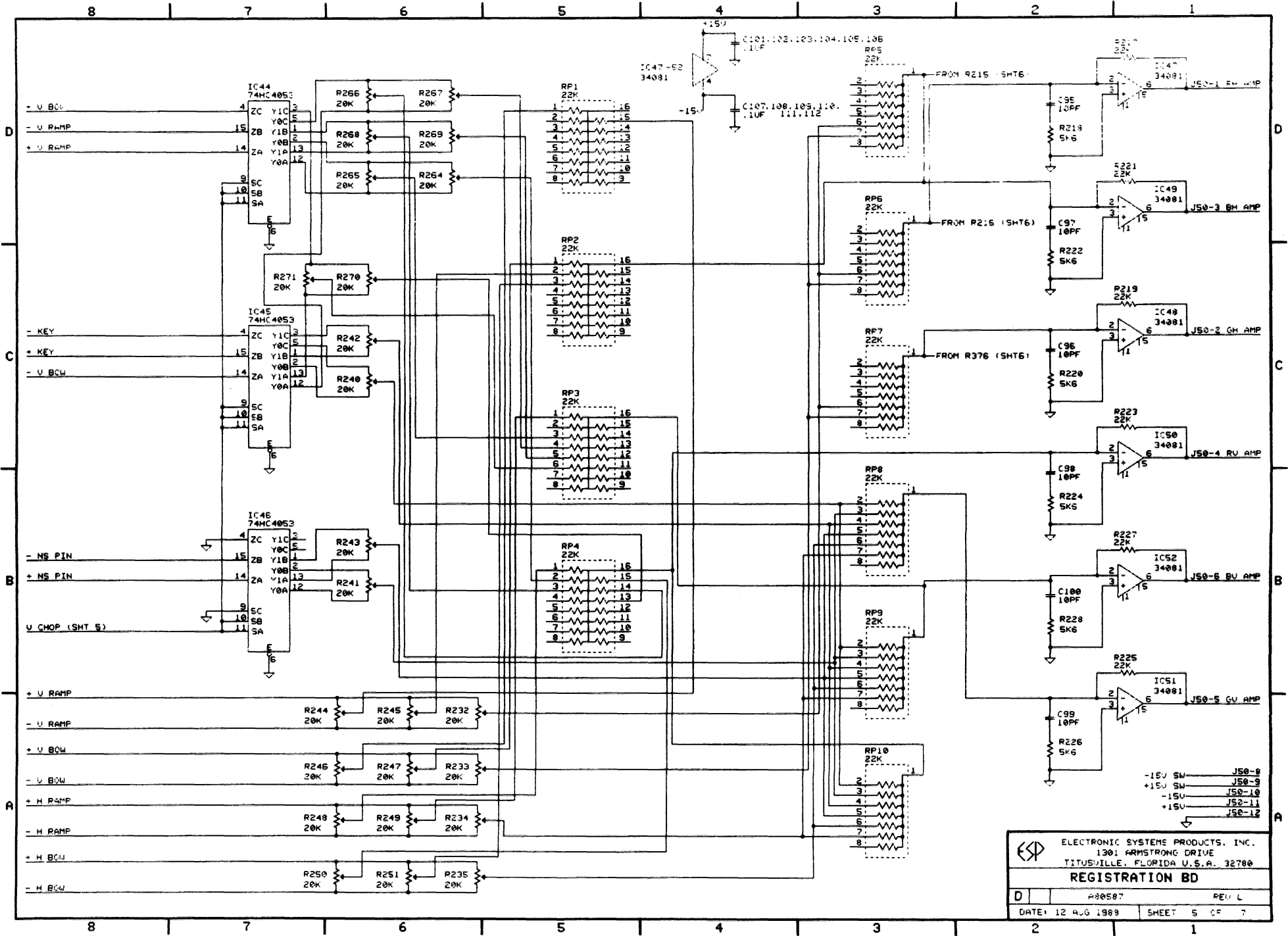
50



ELECTRONIC SYSTEMS PRODUCTS, INC.  
 1301 ARMSTRONG DRIVE  
 TITUSVILLE, FLORIDA U.S.A. 32780

**REGISTRATION BD**

D	80587	REV L
DATE: 12 AUG 1989	SHEET 5 OF 7	

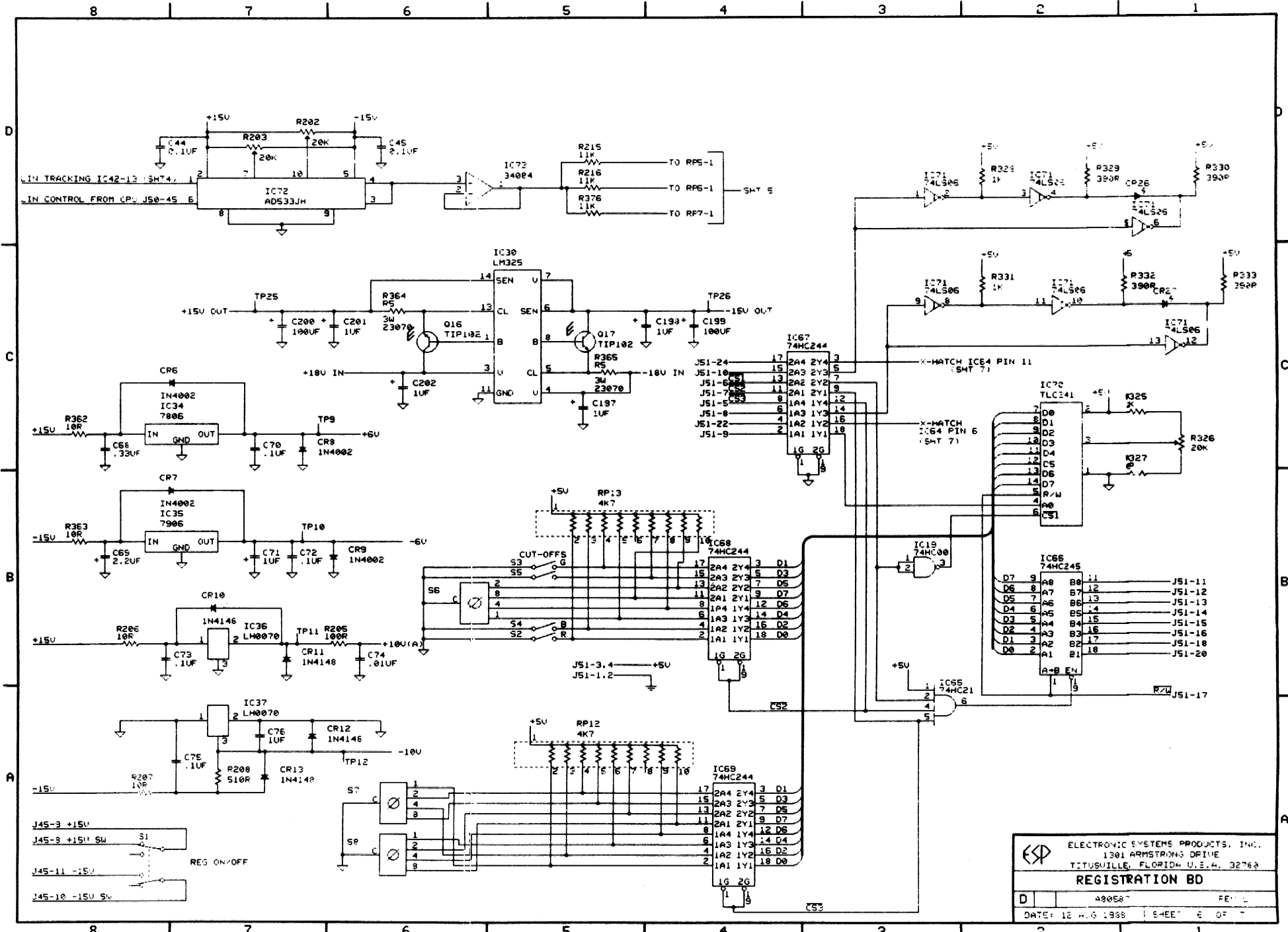

**ELECTRONIC SYSTEMS PRODUCTS, INC.**  
 1301 ARMSTRONG DRIVE  
 TITUSVILLE, FLORIDA U.S.A. 32784  
**REGISTRATION BD**  
 D 490587 REV. L  
 DATE: 12 AUG 1968 SHEET 6 OF 7



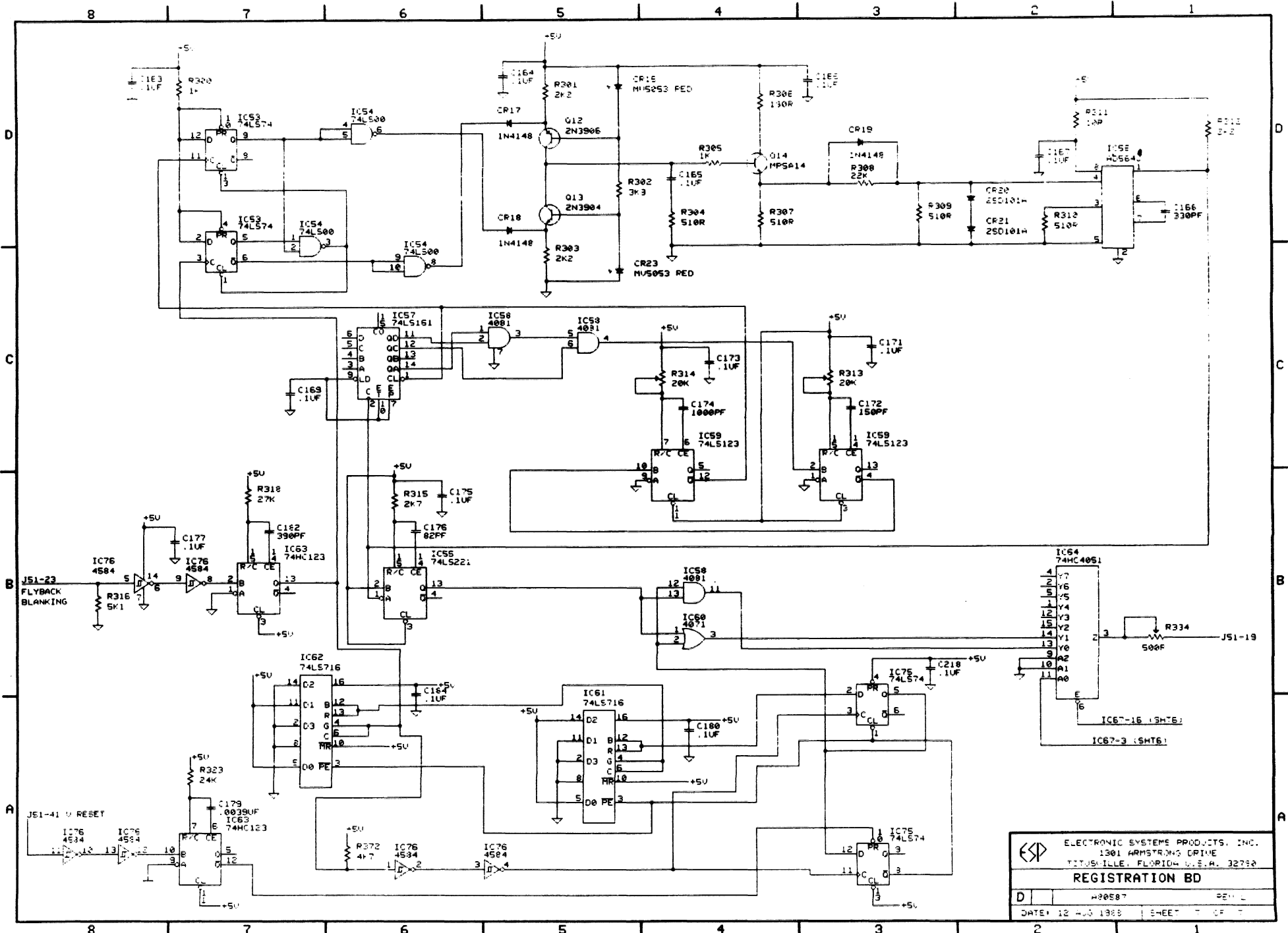

 ELECTRONIC SYSTEMS PRODUCTS, INC. 1301 ARMSTRONG DRIVE TITUSVILLE, FLORIDA U.S.A. 32780		
<b>REGISTRATION BD</b>		
D	H80587	REV. L
DATE: 12 AUG 1985	SHEET 7 OF 7	

52

53

BLUE VERT

GRN VERT

RED VERT

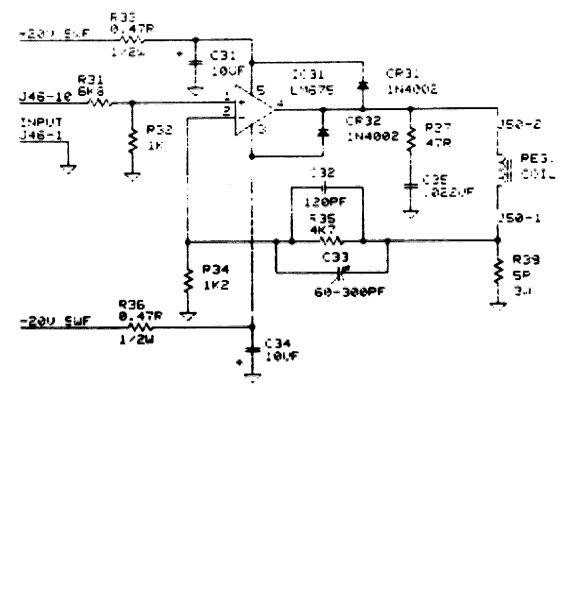
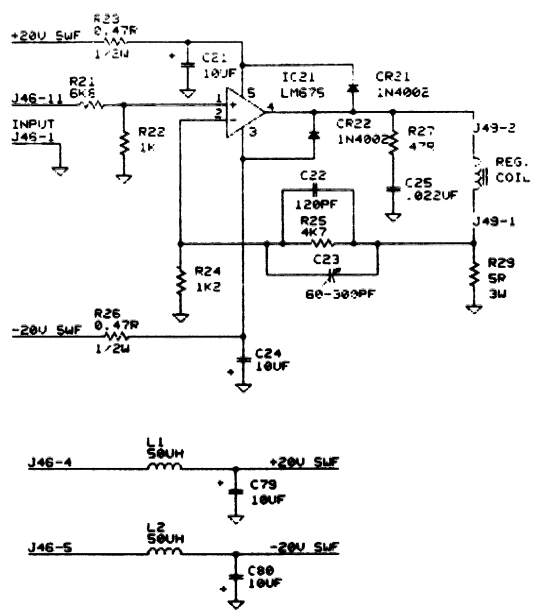
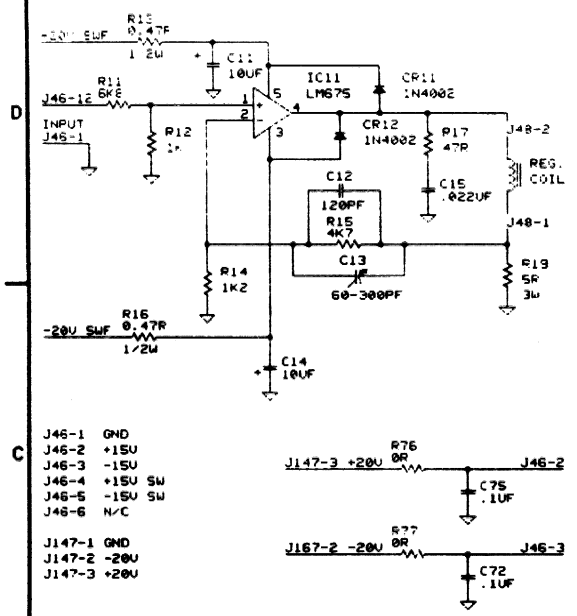

BLUE HORIZ

GRN HORIZ

RED HORIZ

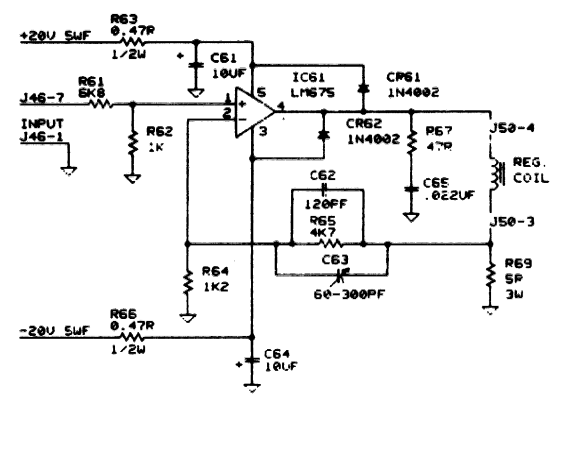
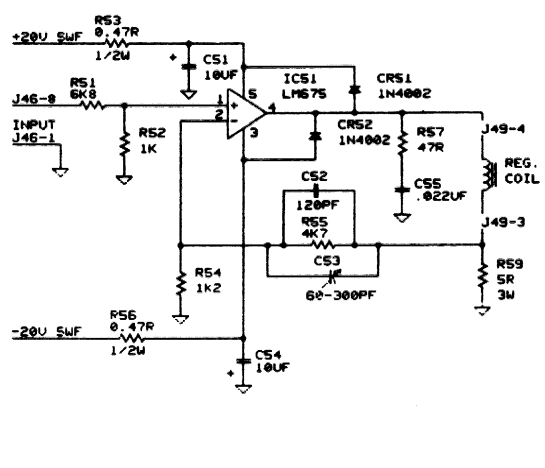
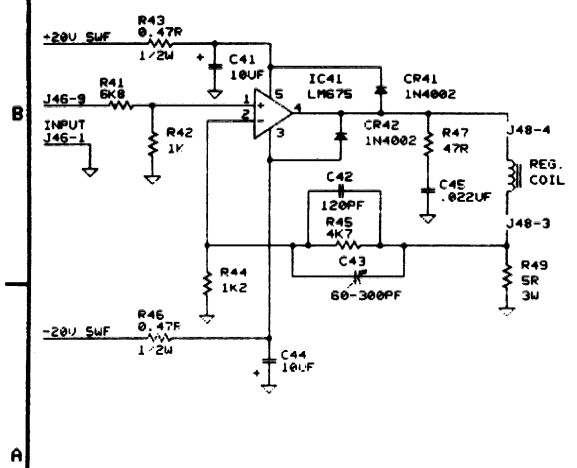

2. THIS SCHEMATIC CONTAINS PROPRIETARY DATA.  
 1. ALL RESISTORS ARE 1/4W UNLESS NOTED.

NOTES:

 ELECTRONIC SYSTEMS PRODUCTS, INC. 1301 ARMSTRONG DRIVE TITUSVILLE, FLORIDA U.S.A. 32780		
<b>300/500 REGISTRATION AMPS</b>		
D	30645	REV D
DATE: 8 SEPT 1983 SHEET 1 OF 1		

BLUE UERT

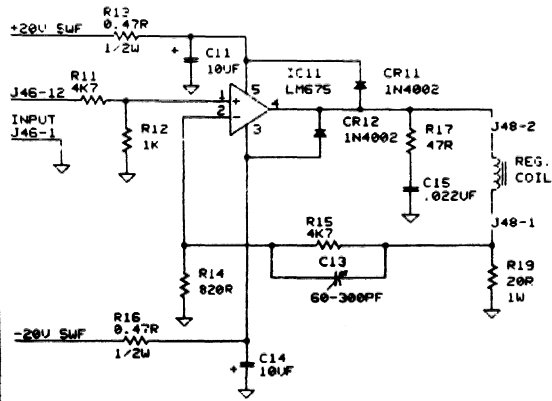

J46-1 GND  
 J46-2 +15V  
 J46-3 -15V  
 J46-4 +15V SW  
 J46-5 -15V SW  
 J46-6 N/C  
 J47-1 GND  
 J47-2 -20V  
 J47-3 +20V

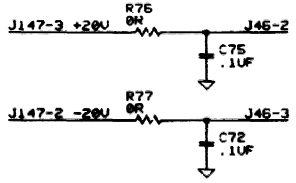

GRN UERT

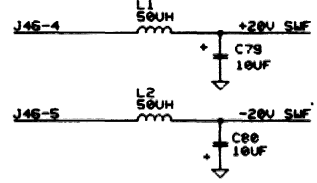
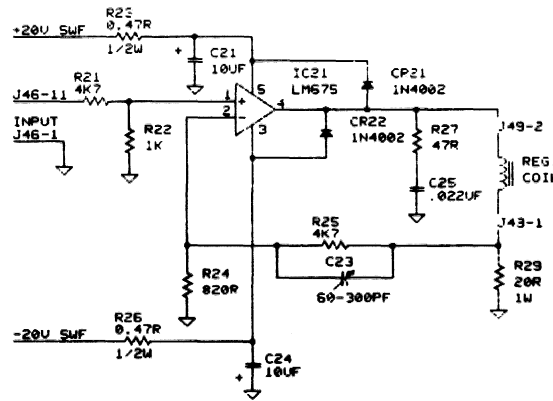

RED UERT

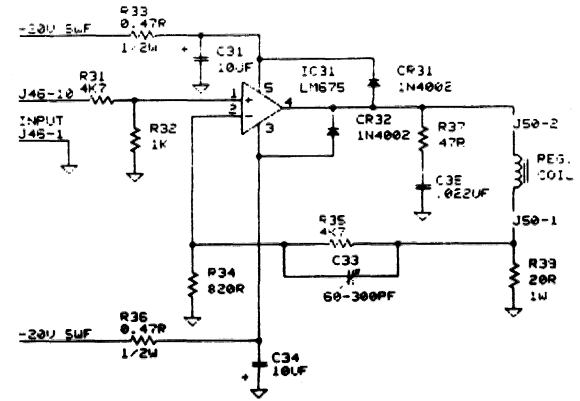

BLUE HORIZ

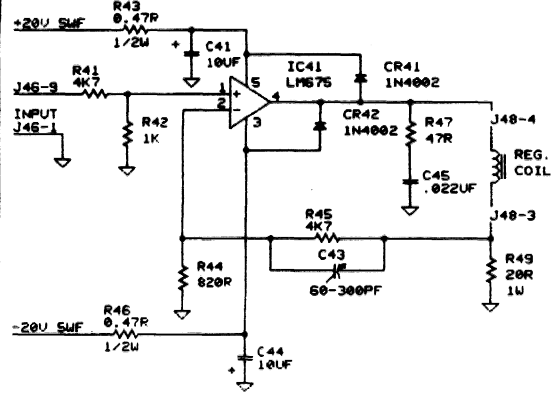

GRN HORIZ

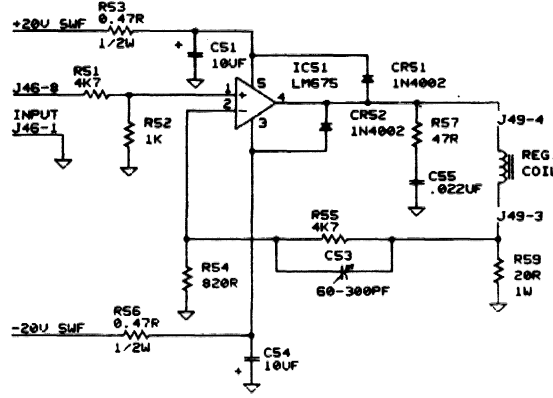

RED HORIZ

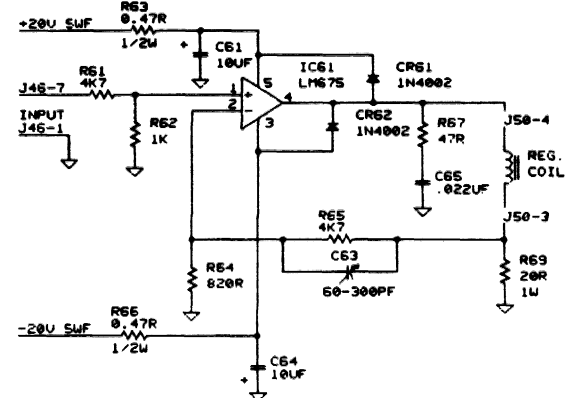

2. THIS SCHEMATIC CONTAINS PROPRIETARY DATA.  
 1. ALL RESISTORS ARE 1/4W UNLESS NOTED.

NOTES:

 ELECTRONIC SYSTEMS PRODUCTS, INC. 1301 ARMSTRONG DRIVE TITUSVILLE, FLORIDA U.S.A. 32780		
<b>535 REGISTRATION AMPS</b>		
D	80693	REV. B
DATE: 6 SEPT 1988	SHEET 1 OF 1	

54

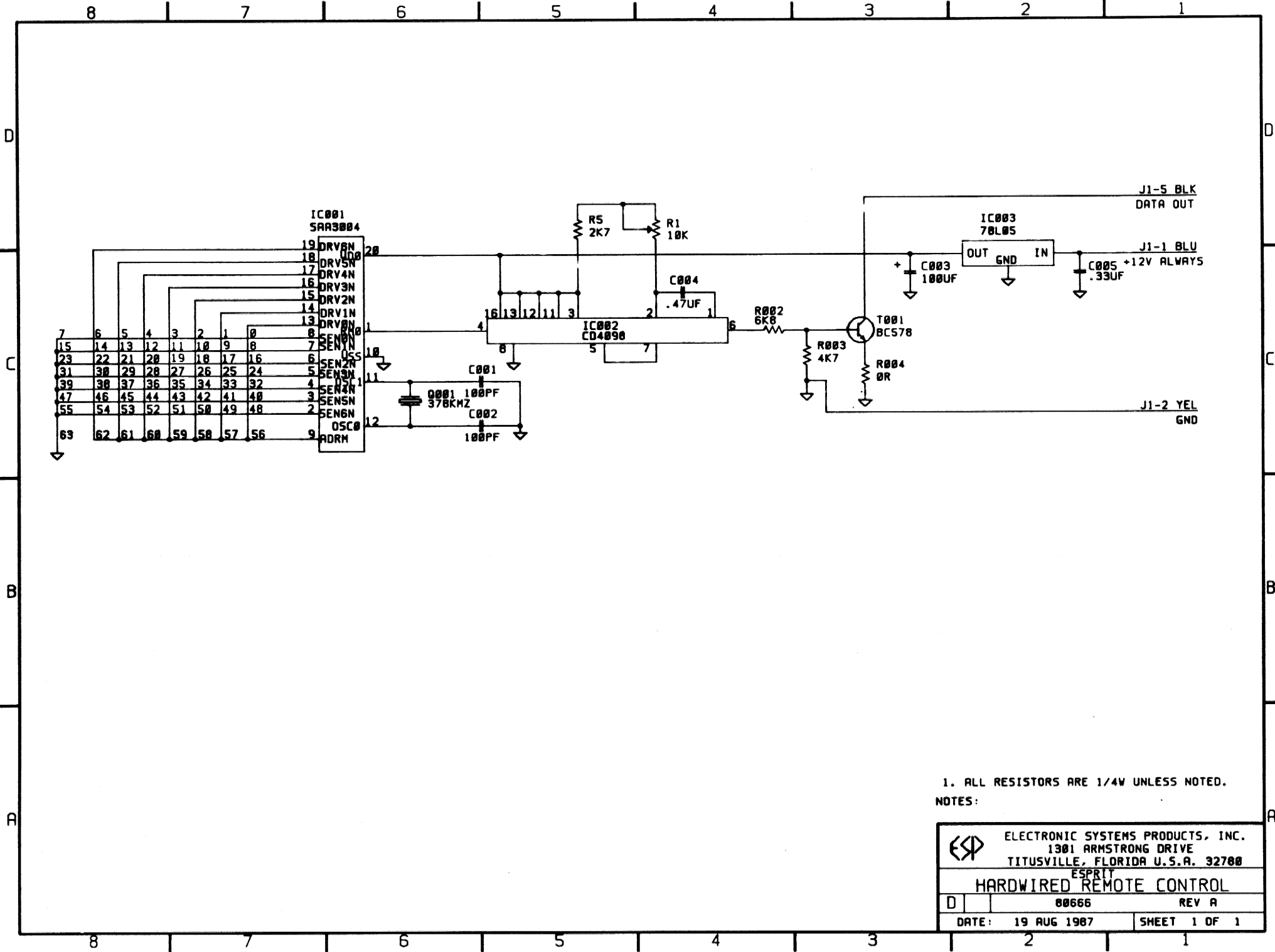

19	DRV8N	20
18	DRV5N	19
17	DRV4N	18
16	DRV3N	17
15	DRV2N	16
14	DRV1N	15
13	DRV0N	14
8	SEN8N	7
7	SEN7N	6
6	SEN6N	5
5	SEN5N	4
4	SEN4N	3
3	SEN3N	2
2	SEN2N	1
1	SEN1N	0
9	OSCR	8
10	ADRM	9

1. ALL RESISTORS ARE 1/4W UNLESS NOTED.  
 NOTES:

 ELECTRONIC SYSTEMS PRODUCTS, INC. 1301 ARMSTRONG DRIVE TITUSVILLE, FLORIDA U.S.A. 32780		
		ESPRTT <b>HARDWIRED REMOTE CONTROL</b>
D	80666	REV A
DATE:	19 AUG 1987	SHEET 1 OF 1

56

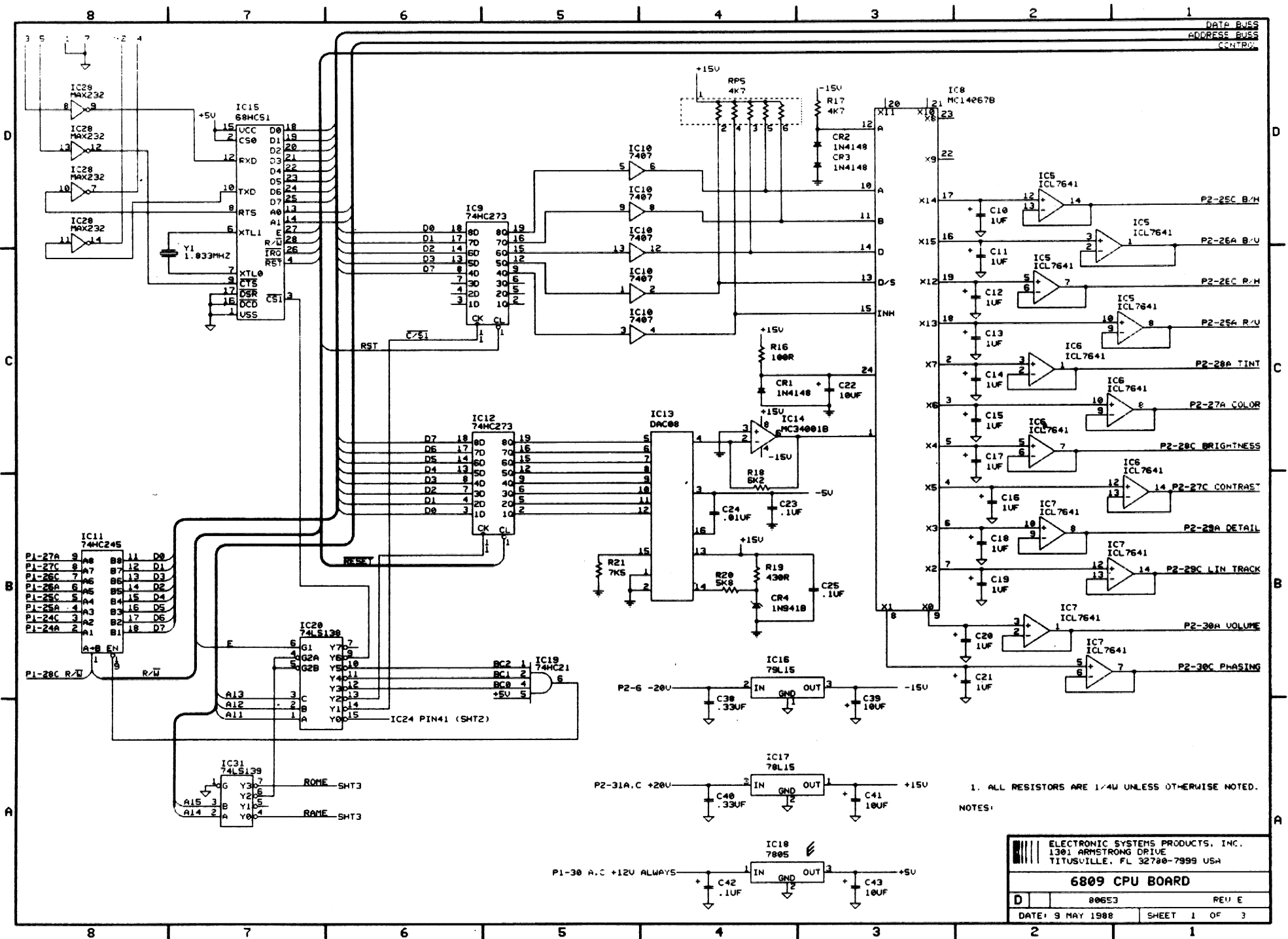

1. ALL RESISTORS ARE 1/4W UNLESS OTHERWISE NOTED.  
 NOTES:

ELECTRONIC SYSTEMS PRODUCTS, INC. 1301 ARMSTRONG DRIVE TITUSVILLE, FL 32780-7999 USA		
<b>6809 CPU BOARD</b>		
D	80653	REV E
DATE: 9 MAY 1988	SHEET 1 OF 3	

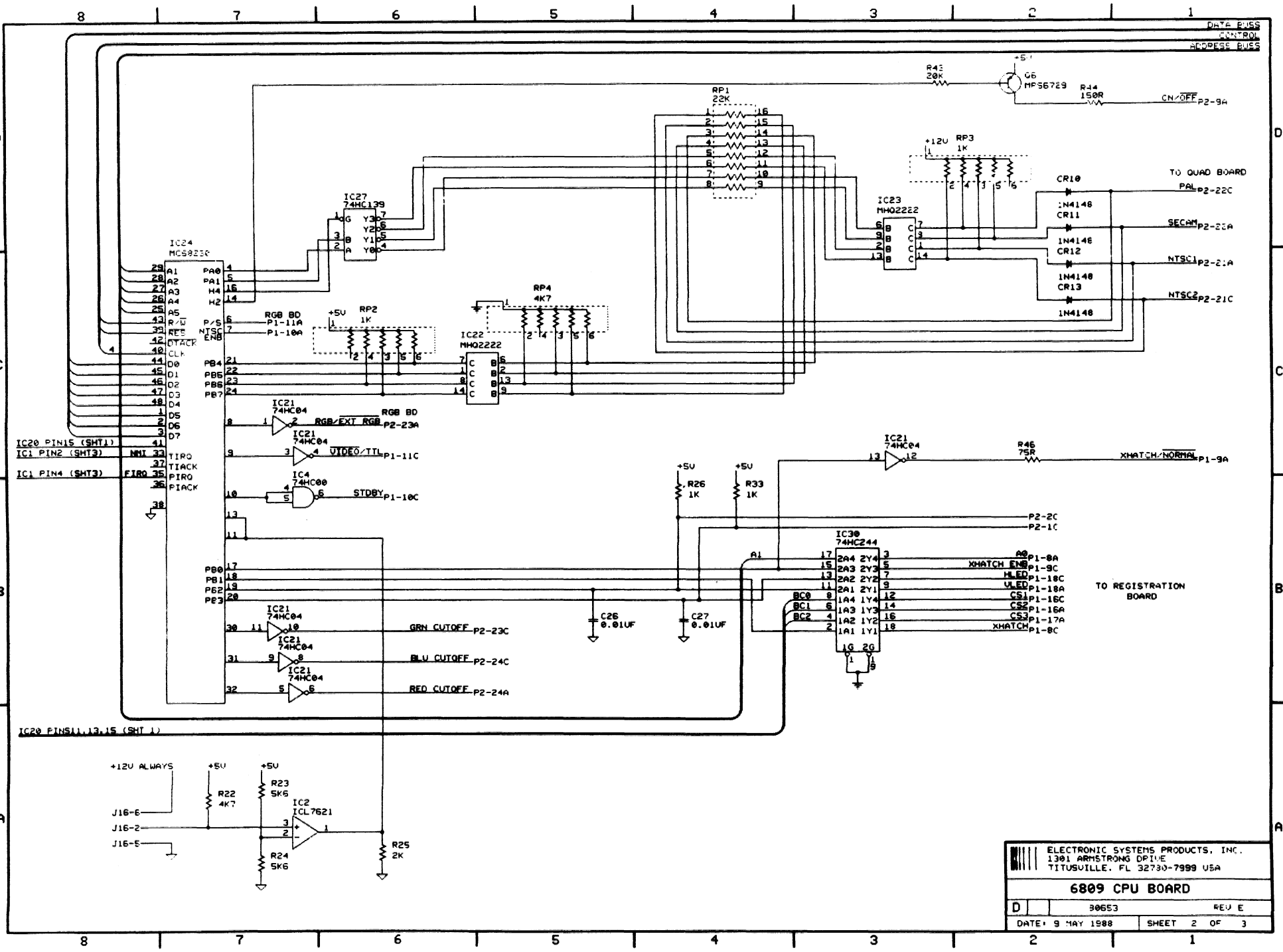

ELECTRONIC SYSTEMS PRODUCTS, INC.  
 1391 ARMSTRONG DRIVE  
 TITUSVILLE, FL 32730-7999 USA

**6809 CPU BOARD**

30653 REV E

DATE: 9 MAY 1988 SHEET 2 OF 3

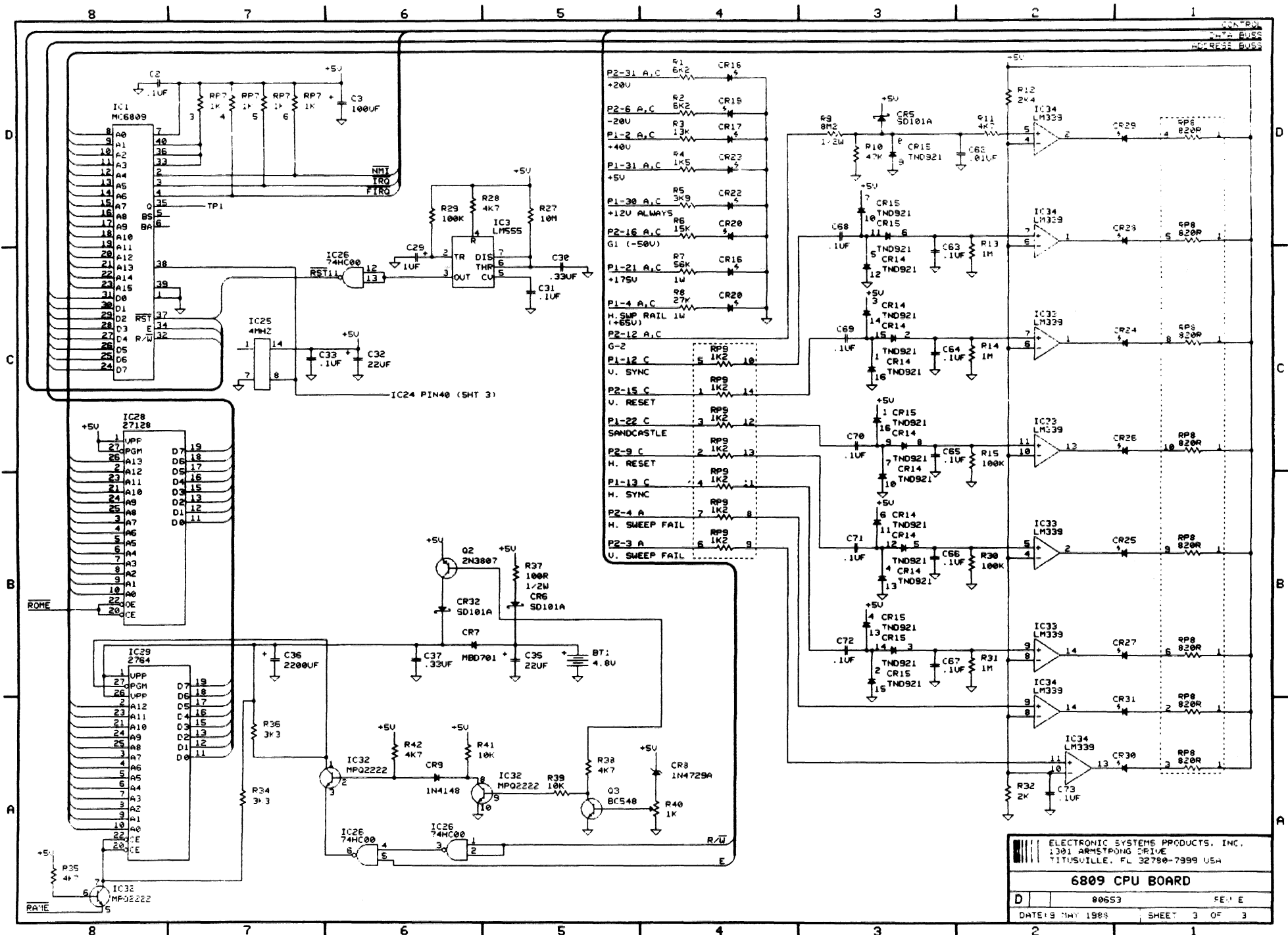

ELECTRONIC SYSTEMS PRODUCTS, INC.  
 1301 ARMSTRONG DRIVE  
 TITUSVILLE, FL 32780-7999 USA

**6809 CPU BOARD**

D 80653 FE: E  
 DATE: 9 MAY 1988 SHEET 3 OF 3

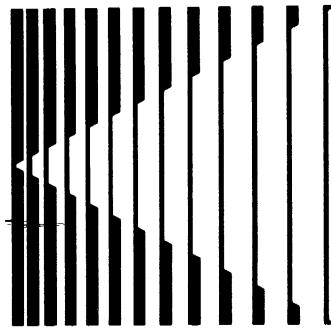

**ELECTRONIC  
SYSTEMS  
PRODUCTS™**

**1301 ARMSTRONG DRIVE  
TITUSVILLE, FL 32780**

**407/269-6680**