

NEC

MODEL ISS-6010
ISS-6010G
IBE, INC.

SYSTEM INTERFACE

OPERATION MANUAL

PART NO. 399910770



**Better Service
Better Reputation
Better Profit**

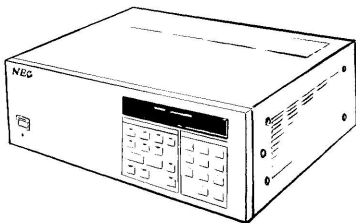

SAFETY CAUTION:

Before servicing this chassis, it is important that the service technician read and follow the "Safety Precautions" and "Product Safety Notice" in this Service Manual.

WARNING:

SHOCK HAZARD — Use an isolation transformer when servicing.

NEC Corporation

TOKYO, JAPAN

NEC INTELLIGENT SWITCHER SYSTEM



REMOTE



RGB PAL SECAM NTSC4 43 NTSC3 58 S-VIDEO

LEVEL REMOTE SENSOR SELECT COUNTER

CONTROL

GAIN: R G B

AUDIO

PICTURE: SHARPNESS COLOR TINT

LEVEL: - + STORE

MUTE: PICTURE AUDIO

NORMAL

INPUT SELECTOR

1 2 3

4 5 6

7 8 9

0 ENTER

INTRODUCTION

Before operating this Switcher, please read this manual carefully and completely. This manual will provide you with a full understanding of the many features, and the necessary instructions for adjustment and operation of the Switcher. Procedures which require the opening of the Switcher and contact with electrical components should be performed by service personnel. For continued safe and reliable operation, use only cables supplied by the manufacturer for power. Adhere to all notes and warnings.

Features

- ◆ Modular construction
- ◆ Accepts 10 inputs; Up to 4 RGB OUTPUT modules can be installed
- ◆ EQ switch corrects the frequency response when using a long cable
- ◆ Accepts NTSC, PAL and SECAM video standards with a multi-synchronous function
- ◆ EXT CONTROL Terminal for connection to an external control unit for power on/off, input switching, picture mute and sound mute functions
- ◆ REMOTE Terminal for direct connection of PC



Important Safeguards

The following are important safety instructions designed to ensure the long life of your Switcher and to prevent fire and shock hazards. Be sure to read these safety instructions carefully and follow all warnings given below.

On installation

Place the Switcher on a flat, level surface and in a dry area free from dust and moisture. Do not place the Switcher in direct sunlight, near stoves or other heat radiating appliances. Smoke, steam and exposure to direct sunlight could adversely affect the internal components. Avoid rough handling when moving your equipment as a strong shock could damage its internal components. If installing the Switcher in a rack, use only parts supplied by the manufacturer. Observe all instructions and warnings.

Power supply

The Switcher is designed to operate on 120V 60Hz (ISS-6010), 220/240V 50Hz (ISS-6010G) AC power supply. Make sure your local power supply matches these requirements before operation. If not, consult with your dealer to arrange for the required modifications before operation.

Handle the power cord carefully and avoid excessive bending. A damaged cord may cause electric shock or fire. If the Switcher is not to be used for an extended period, remove the plug from the wall outlet.

Cleaning

Unplug the Switcher from the power outlet before cleaning.

Clean the cabinet and front panel periodically with a soft cloth. If heavily stained, use a mild detergent solution. Never use strong detergents or solvents such as alcohol or thinner to clean your Switcher.

Fire and Shock Precautions

Adequate ventilation must be provided to prevent heat build-up inside the Switcher. Make sure the ventilation holes are unobstructed.

Keep the inside of the Switcher free from foreign objects, such as paper clips, nails, paper, etc., and do not attempt to retrieve such objects yourself or insert metal objects such as wire and screw-drivers inside the Switcher. If a hazardous object falls inside the Switcher, unplug it immediately and call a qualified electrical repairman for removal.

Do not set liquids on top of the Switcher.

Contents

INTRODUCTION	3
Features	
Important Safeguards	
PART NAMES AND FUNCTIONS	6
Front view	
LED	
Rear view	
Optional modules	
Optional remote control unit	
SERVICE SWITCH FUNCTIONS	12
EQ SW(S1001)	
H/SYNC Select Switch(S1002)	
VIDEO MODE Select Switch(S3001)	
VGA/PGA Select Switch(S4001)	
EXAMPLES OF CONNECTIONS	14
Connecting with the Projector and a Personal Computer	
Connecting with a VCR and Audio Equipment	
Connecting with a Document Camera and a Monitor	
D-SUB 15 PIN TERMINALS	18
EXT CONTROL Terminal	
REMOTE 1 and 2 Terminals	
INSTALLATION	21
Module Installation	
Rack Mounting	
SPECIFICATIONS	22
APPENDIX	23
Command reference	

PART NAMES AND FUNCTIONS

Front view

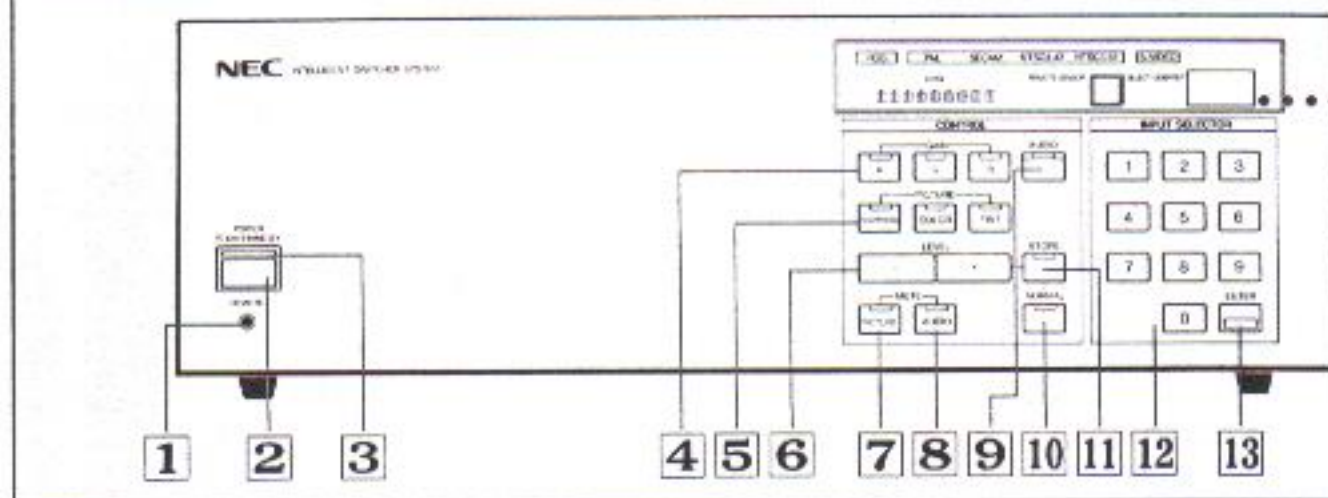

1 REMOTE Jack

Insert the connector of the handheld remote cable included with the Projector here.

2 POWER Button

Turns the power on or off. Prior to this, be sure to set the POWER switch on the rear to ON.

3 POWER Indicator

Indicator is red when in stand-by and turns green upon power up.

4 GAIN Controls

R-GAIN Button/Indicator

Press to select R-GAIN mode. Indicator will light up. The gain for Red can be adjusted with the LEVEL buttons + or - until the desired red gain is obtained. To complete this adjustment, press R-GAIN again.

G-GAIN Button/Indicator

Press to select G-GAIN mode. Indicator will light up. The gain for Green can be adjusted with the LEVEL buttons + or - until the desired green gain is obtained. To complete this adjustment, press G-GAIN again.

B-GAIN Button/Indicator

Press to select B-GAIN mode. Indicator will light up. The gain for Blue can be adjusted with the LEVEL buttons + or - until the desired blue gain is obtained. To complete this adjustment, press B-GAIN again.

NOTE: Pressing one of the R, G and B button with holding down another affects all the three colors and allows you to adjust the gain of all three settings simultaneously. This operation will apply only to stand alone mode.

NOTE: Whenever any one of the R, G and B buttons is pressed in GP-3000/5000 operation, the GAIN mode will be selected in the following order:

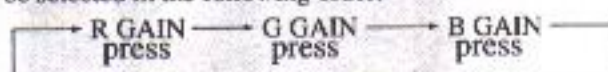

5 PICTURE Controls

SHARPNESS Button/Indicator

Press to select the Sharpness mode. Indicator will light up. The Sharpness control can be adjusted with the LEVEL buttons + or -. To complete this adjustment, press SHARPNESS again.

COLOR Button/Indicator

Press to select the Color mode. Indicator will light up. The Color control can be adjusted with the LEVEL buttons + or -. To complete this adjustment, press COLOR again.

TINT Button/Indicator

Press to select the Tint mode. Indicator will light up. The Tint control can be adjusted with the LEVEL buttons + or -. To complete this adjustment, press TINT again.

NOTE: The Tint control works only for NTSC 4.43 and NTSC 3.58 system.

NOTE: The Color, the Tint and the Sharpness controls do not work for RGB signals.

NOTE: Whenever any one of the SHARPNESS, COLOR and TINT buttons is pressed in GP-3000/5000 operation, the picture function will be selected in the following order:

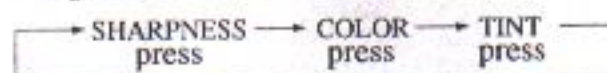

6 LEVEL Buttons (+ , -)

Use these buttons for gain, sharpness, color, tint and audio adjustments.

7 PICTURE MUTE Button

Press to mute the picture. Indicator will light up. Press once again to return to the picture.

8 AUDIO MUTE Button

Press to mute the sound. Indicator will light up. Press once again to return to the sound.

LED

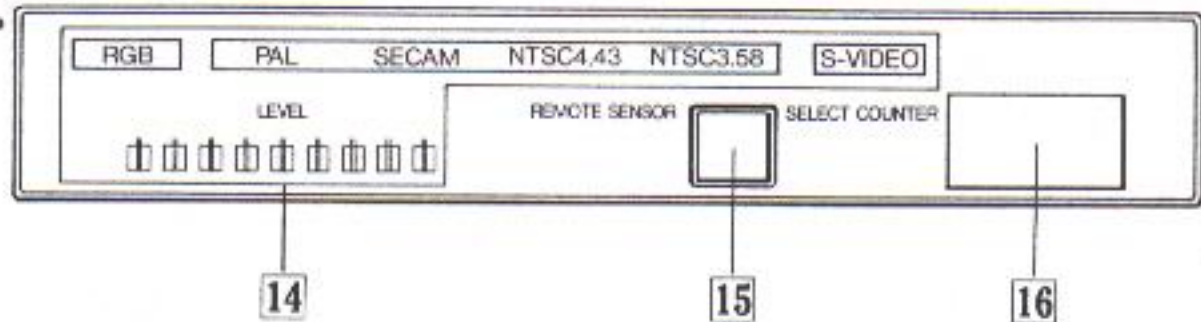
**9 AUDIO Control Button**

Press to select the Audio output control mode. Indicator will light up. The Audio output can be adjusted with the LEVEL buttons + or - . To complete this adjustment, press AUDIO again.

10 NORMAL Button

To return to the factory preset level:

Press to return the adjustments level for each video or RGB input signal to its original factory preset level. When pressed once, the indicator begins blinking for the confirmation. When pressed the second time, the indicator will end its blinking status to indicate that the function is executed. To cancel, press any one of the buttons other than the NORMAL button while the indicator is blinking.

To return to the last stored level:

Press the NORMAL button while holding down the ENTER button. The indicators of the NORMAL and STORE will begin to blink. Press again to return to the last stored adjustment level. The indicators will end their blinking status. To cancel, press any one of the buttons other than the NORMAL button while the indicators are blinking. Note that the last stored function works only with the Switcher in stand alone operation.

11 STORE Button

Press to store the setting data of each video or RGB input signal in memory. When pressed once, the indicator begins blinking for the confirmation. When pressed the second time, the indicator will end its blinking status to indicate that the data has been stored in memory. To cancel, press any one of the buttons other than the STORE button while the indicator is blinking. Note that the indicator blinks only with the Switcher in stand alone operation.

12 INPUT Button (Ten keys)

The numbers correspond to the slot in which the module is installed.

Press a slot number button. The selected number starts blinking in the SELECT COUNTER window. Press the ENTER button to change the selected number from blinking to steady light in the SELECT COUNTER window. At the same time the ACTIVE indicator on the rear of the corresponding module will light.

NOTE: The indicator blinks only with the Switcher in stand alone operation.

NOTE: The input will be automatically switched to the selected input in about 2 seconds.

13 ENTER Button

Press to enable the selected input.

14 Indicators

- **RGB Indicator**
Lights up when an RGB signal is selected.
- **PAL Indicator**
Lights up when a PAL signal is selected.
- **SECAM Indicator**
Lights up when a SECAM signal is selected.
- **NTSC4.43 Indicator**
Lights up when an NTSC4.43 signal is selected.
- **NTSC3.58 Indicator**
Lights up when an NTSC3.58 signal is selected.
- **S-VIDEO Indicator**
Lights up when the cable is connected to an S-VIDEO terminal on the selected VIDEO INPUT MODULE.
- **LEVEL Indicator**
Indicates the adjustment level.

15 REMOTE SENSOR

Receives signals from the wireless remote (optional).

16 SELECT COUNTER

Displays the selected slot number.

PART NAMES AND FUNCTIONS

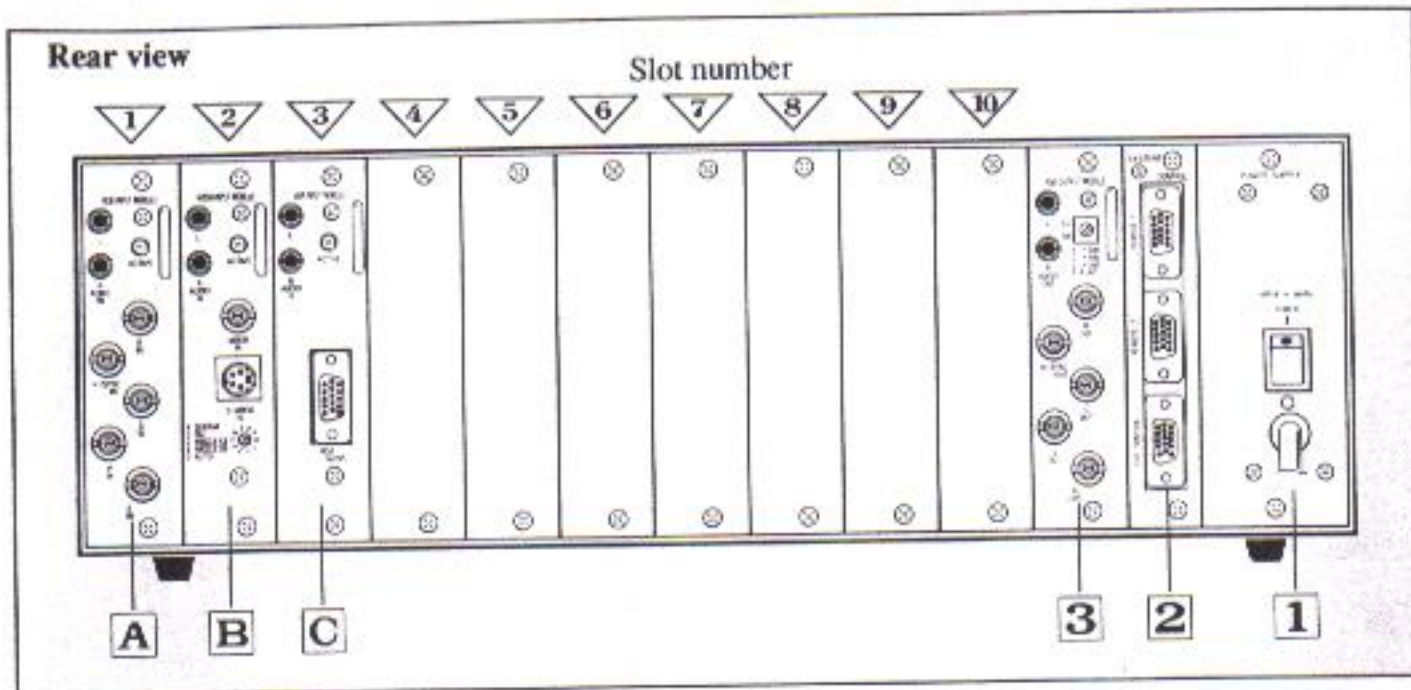

1 POWER SUPPLY MODULE

POWER Switch (main power)

Press to the ON position to enter the stand-by condition. In this condition the Switcher can be turned on and off with POWER button on the front or the remote control (optional). To turn off the main power, press the OFF side.

2 SYSTEM CONTROL MODULE

REMOTE 1 Terminal (D-SUB 15 pin)

Connects the REMOTE terminal of the projector if the Switcher is used in conjunction with a compatible brand projector. This terminal sends and receives various data.

REMOTE 2 Terminal (D-SUB 15 pin)

Connects to a personal computer or an external control device.

EXT CONTROL Terminal (D-SUB 15 pin)

Used when power on/off, input selection, picture muting and audio muting are operated by an external control device.

3 RGB OUTPUT MODULE(6010-OUTRGB)

RGB Output Terminals

Connects to RGB input terminals of an external equipment (projector, etc.).

H/SYNC Output Terminal

Connects to the horizontal or the sync input terminal of the external equipment.

V Output Terminal

Connects to the vertical input terminal of the external equipment.

AUDIO L, R Output

Connects to audio input terminal of the external equipment.

EQ Switch

For service personnel only. Refer to page 12 for more information.

H/SYNC Select Switch (Internal switch)

For service personnel only. Refer to page 12 for more information.

NOTE: Up to 4 RGB OUTPUT modules can be accepted. Therefore, 3 more optional RGB output modules can be installed. It is recommended that you should use slots 10 through 8 in descending order for installing optional RGB output modules.

Optional modules

Optional modules can be purchased from your local dealer.

A RGB INPUT MODULE (6010-RGB)

Use to connect to external equipment providing R. G. B. H. V. , R. G. B. SYNC outputs, or R Gs B. **ACTIVE Indicator (green)**

Lights up when the slot containing this RGB INPUT MODULE is selected.

RGB Input Terminals

Connects to RGB output terminals of the external RGB source.

H/SYNC Input Terminal

Connects to the horizontal or the sync output terminal of the external RGB source.

V Input Terminal

Connects to the vertical output terminal of the external RGB source.

AUDIO L, R Input Terminals

Connects to audio output terminals of the external audio source.

B VIDEO INPUT MODULE (6010-VID)

Use to connect to a VCR, laser disc or other video signal.

ACTIVE Indicator (green)

Lights up when the slot containing this VIDEO INPUT MODULE is selected.

VIDEO Input Terminal

Connects to a video output terminal of the external source such as a VCR.

S-VIDEO Input Terminal

Connects to an S-video output terminal of the external source such as a VCR.

AUDIO L, R Input Terminals

Connects to audio output terminals of the external source such as audio system.

Video Mode Select Switch

For service personnel only. Refer to page 12 for more information.

NOTE :

- The S-VIDEO input has priority over the VIDEO input if a component connected to each terminal at the same time.
- A single QUAD DECODER (6010-QUAD) board is required when any amount of VIDEO INPUT modules are used. QUAD DECODER is a circuit board which converts a VIDEO signal into an RGB signal. Unqualified persons should not attempt to install a QUAD DECODER. When you use a VIDEO INPUT MODULE, contact your dealer.

C VGA INPUT MODULE (6010-VGA)

Use to connect an IBM computer such as IBM PC, PC/XT, PC/AT, PS/2 or IBM compatible VGA, XGA and PGA.

ACTIVE Indicator (green)

Lights up when the slot containing this VGA INPUT MODULE is selected.

RGB Input Terminal (D-SUB 15 pin)

Connects to an RGB analog output terminal of external equipment such as a personal computer, etc.

AUDIO L, R Input Terminals

Connects to audio output terminals of the external equipment.

VGA/PGA Select Switch (Internal switch)

For service personnel only. Refer to page 13 for more information.

PART NAMES AND FUNCTIONS

Optional remote control unit (RC-6010)

The optional remote control unit can operate this Switcher for the following control functions.

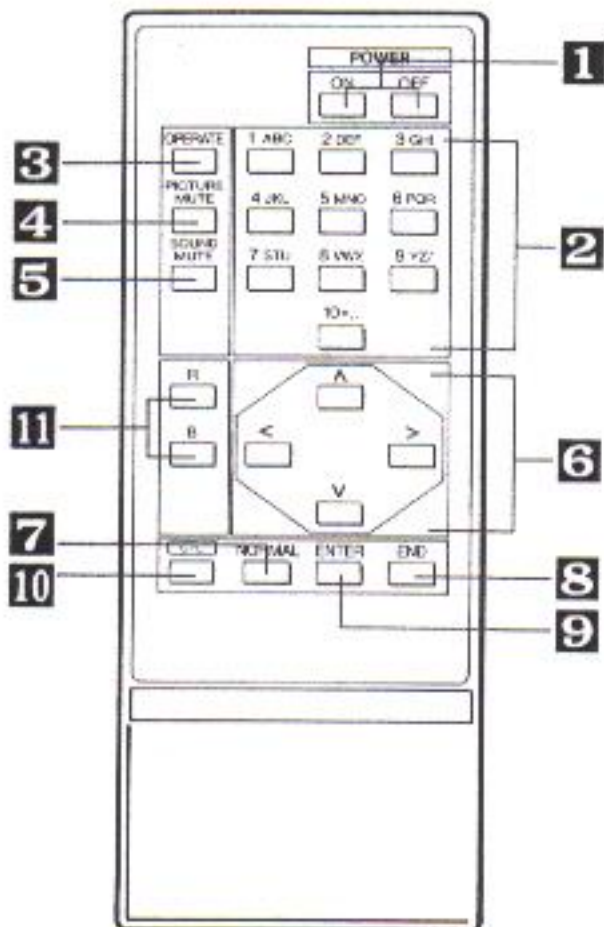

1 POWER ON/OFF Buttons

When the Switcher is in the stand-by mode the POWER indicator lights up in red. When the ON button is pressed, the power goes on. When the OFF button is pressed, the Switcher will return to the stand-by mode.

2 INPUT Buttons

Each button number corresponds to the number of slots in which the input modules are installed. To select the input source to be monitored, press the INPUT button to input the slot number. The selected number starts blinking in the SELECT COUNTER window. Press the ENTER button to execute the input selection. The selected number changes from blinking to steady light. At the same time the ACTIVE indicator on the corresponding input module will light up.

NOTE: The indicator blinks only with the Switcher in stand alone operation.

NOTE: The input will be automatically switched to the selected input in about 2 seconds.

3 OPERATE Button

Selects various adjustment functions. Whenever the OPERATE button is pressed, the functions change as follows:

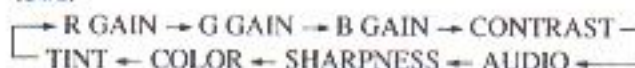

NOTE: When PICTURE MUTE is on, the picture functions will be skipped.

When SOUND MUTE is on, the audio function will be skipped.

When a VIDEO signal other than NTSC is selected, TINT will be skipped. When an RGB signal is selected, TINT, SHARPNESS, and COLOR will be skipped.

4 PICTURE MUTE Button

When pressed, the picture is muted, (blanked), and the indicator of the PICTURE MUTE button lights up. When pressed again, the picture is restored.

5 SOUND MUTE Button

When pressed, the sound is muted and the indicator of the AUDIO MUTE button lights up. When pressed again, the sound is restored.

NOTE: It is suggested that this remote control be used in stand alone operation. When connecting the compatible brand projector, use the supplied remote control accompanying the projector. When the ISS-6010 Switcher is used with the GP-3000/GP-5000 projector, this remote control does not work.

6 CURSOR Buttons

Use to adjust RGB GAIN, AUDIO, SHARPNESS, COLOR and TINT control. Press \wedge , $\>$ to increase the selected adjustment level. Press \vee , $\<$ to decrease the selected adjustment level.

7 NORMAL Button

To return picture settings to the factory preset level:
Returns the adjustments for each VIDEO or RGB input signal to the normal factory setting. When pressed, the indicator of the NORMAL button on the front begins blinking for confirmation. When pressed again, the adjustment returns to the normal factory setting and the indicator changes from blinking to steady light. To cancel, press any one of the buttons other than the NORMAL button while the indicator is blinking.

To return to the last stored level:

Press the NORMAL button while holding down the CTL button. The indicators for NORMAL and STORE on the front begins blinking. Press again to return to the last stored level. The indicators will end their blinking status. To cancel, press any one of the buttons other than the NORMAL button while the indicators are blinking.

NOTE: The last stored function works only with the Switcher in stand alone operation.

8 END Button

Ends the adjustment mode. Your adjustments are automatically saved. If you have any problems adjusting, press this button while holding down the CTL button to end the adjustment mode without saving data.

NOTE: The adjustment setting for each VIDEO and RGB input signal is memorized.

9 ENTER Button

Executes switching to the selected input.

10 CTL Button

Used with other buttons, similar to a shift key on a typewriter or computer.

11 R, B Buttons

These buttons are used to select the CRTs (red and blue) to be adjusted only when connected to a compatible brand Projector.

Battery installation and replacement

- ① Press down on the battery compartment cover and slide the cover in the direction of the arrow.

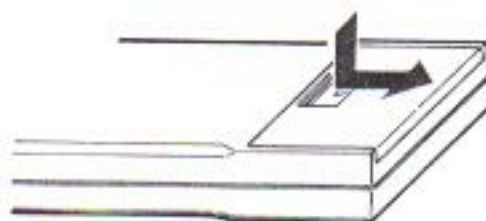

- ② Install the two new batteries, making sure that their polarity matches the (+) (-) diagrams inside the battery compartment. Incorrect polarity could damage the unit.

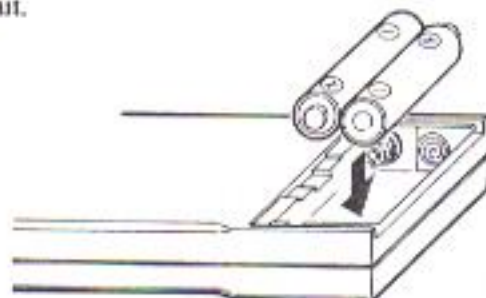

- ③ Close the battery compartment cover.

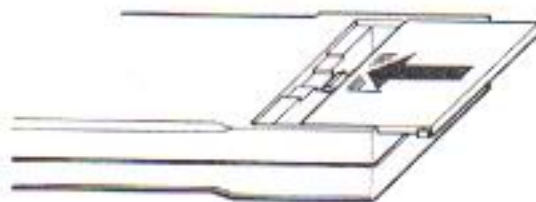

NOTE: The remote control is powered by two 1.5V AA batteries.

Remote control cautions

Use this wireless remote control within the valid operating range within a distance of about 7m (23 ft.) and at 30° angles left and right.

Handling remote control and batteries

Do not drop or mishandle the remote.

Do not get the remote wet. If the remote control happens to get wet, wipe it dry immediately.

Avoid heat and humidity.

When not using the remote control for a long period, remove the batteries.

Do not use new and old batteries together, or use different types together.

Do not take apart the batteries, heat them, or throw them into a fire.

SERVICE SWITCH FUNCTIONS

NOTE:

- Unplug this switcher and the projector from the wall outlet before setting the following switches.
- When using the internal switches of the following, consult your dealer.

EQ SW (S1001)

Switches the video bandwidth of the high frequencies (about 50MHz) as shown below:

Frequency response attenuates in proportion to the length of a cable between the Switcher and the projector / PC.

Therefore, when using a longer cable, use this switch to correct the frequency response.

EQ SW	GAIN(50MHz)dB
1	0
2	+2
3	+4
4	+6



- 4 +6db
- 3 +4db
- 2 +2db
- 1 FLAT

H/SYNC Select Switch (S1002)

H/SYNC select switch is located in the RGB OUTPUT MODULE.

This switch selects either Horizontal sync or composite sync output from H/SYNC output terminal.



H/SYNC Select Switch	Output Signal
SEPA	Horizontal sync signal
MIX	Composite sync signal

VIDEO MODE Select Switch (S3001)

This switch selects Video input mode. Either Auto mode or Manual mode can be selected: In Auto mode the video mode will be automatically selected according to the input signal. In Manual mode, select the video mode by setting this switch according to the video input to be used in your area.

When the auto mode does not function properly due to a weak or noisy signal, manually select the appropriate video mode.

NOTE: The Switcher may not function properly when the monochrome signal without burst signal is accepted in the auto mode.

- 4 SECAM
- 3 PAL
- 2 NTSC4.43
- 1 NTSC3.58
- 0 AUTO



VIDEO MODE Select Switch	Video Mode
0	AUTO
1	NTSC 3.58
2	NTSC 4.43
3	PAL
4	SECAM

VGA/PGA Select Switch (S4001)

VGA/PGA select switch is located in the VGA INPUT MODULE.
This switch selects either a VGA source or a PGA source.

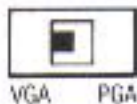

Position of Select SW	Input Source VGA / PGA
VGA position	When connected to a VGA source
PGA position	When connected to a PGA source

EXAMPLES OF CONNECTIONS

CAUTION:

- Unplug this Switcher and other equipment from the wall outlet before making connections.
- Make sure that the plug of the power cord is properly connected to the wall outlet. A loose connection may cause hum or noise.
- Confirm your connection layout with the users manual accompanying the equipment to be connected with the Switcher.

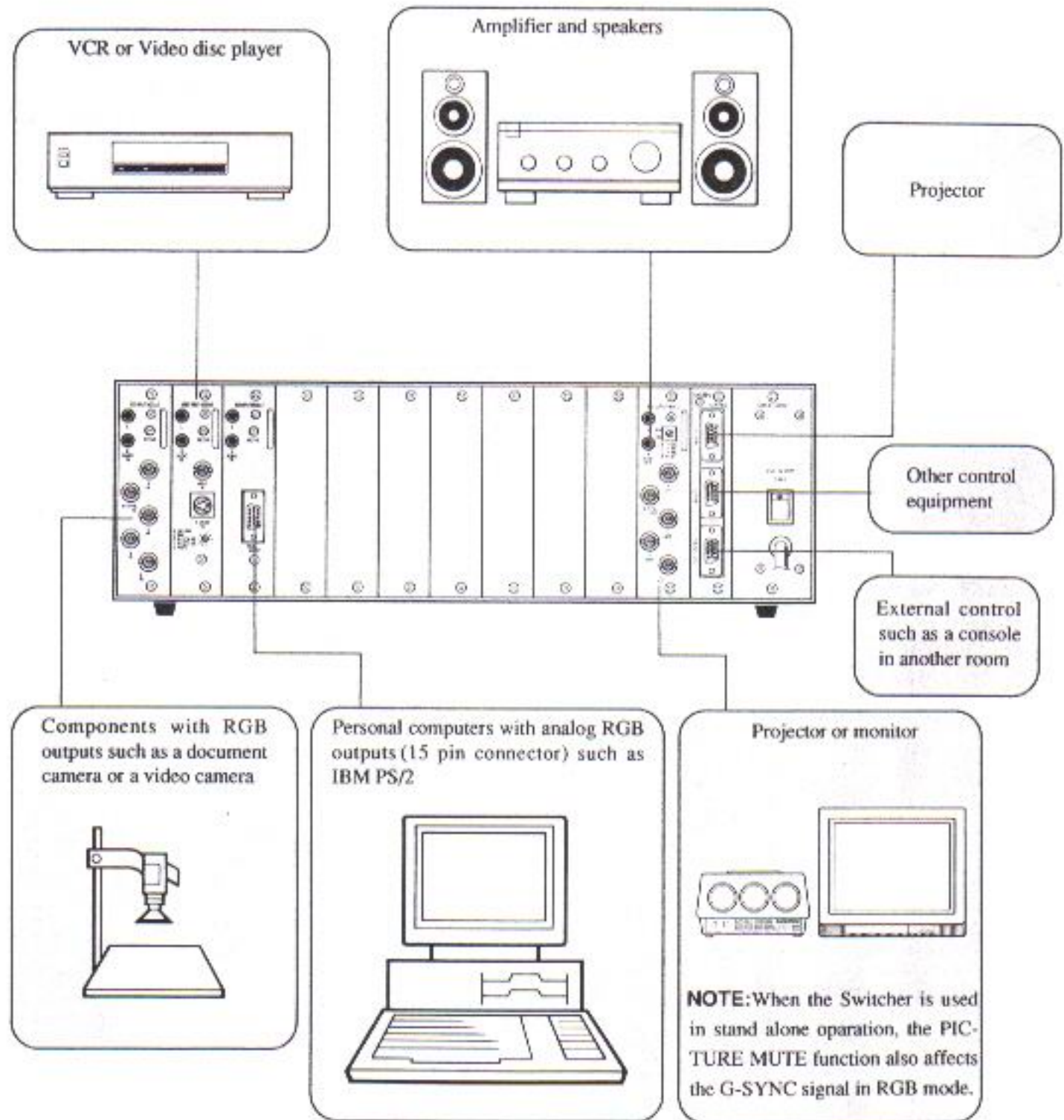

NOTE: Optional modules are indicated by shaded areas.

Connecting with the Projector and a Personal Computer:

The signal from PC output to the projector.

VGA INPUT MODULE

- VGA INPUT MODULE is optional (6010-VGA).
- VGA/PGA select switch should be set according to the input signal.(Refer to page 13.)

RGB OUTPUT MODULE

- EQ switch and H/SYNC select switch should be set according to the mode and the equipment to be used. (Refer to page 12.)

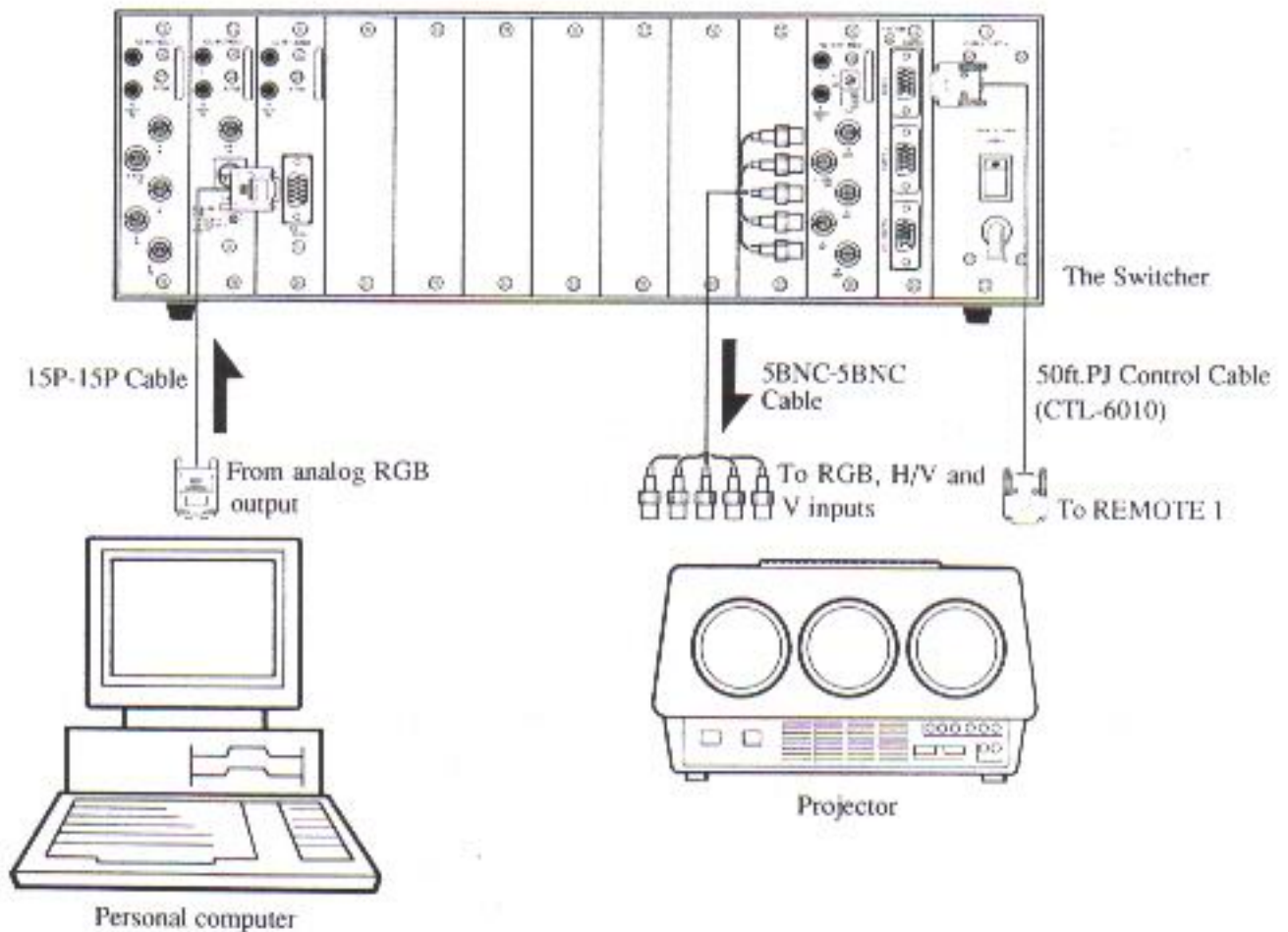

-  shows signal flow.
- For more information on a personal computer and the projector, refer to the user's manual accompanying PC or the projector.
- Cables are not included with the Switcher

EXAMPLE OF CONNECTIONS

Connecting with a VCR and Audio Equipment

The signal from a VCR output to the projector and the audio equipment. Refer to page 15 for connecting with the projector.

VIDEO INPUT MODULE

- VIDEO INPUT MODULE is optional (6010-VID).
- VIDEO MODE select switch should be set according to the signal to be used. (Refer to page 12.)

NOTE: One QUAD DECODER board (optional) must be installed in the Switcher before operation with VIDEO input modules is possible. Consult your dealer for this procedure.

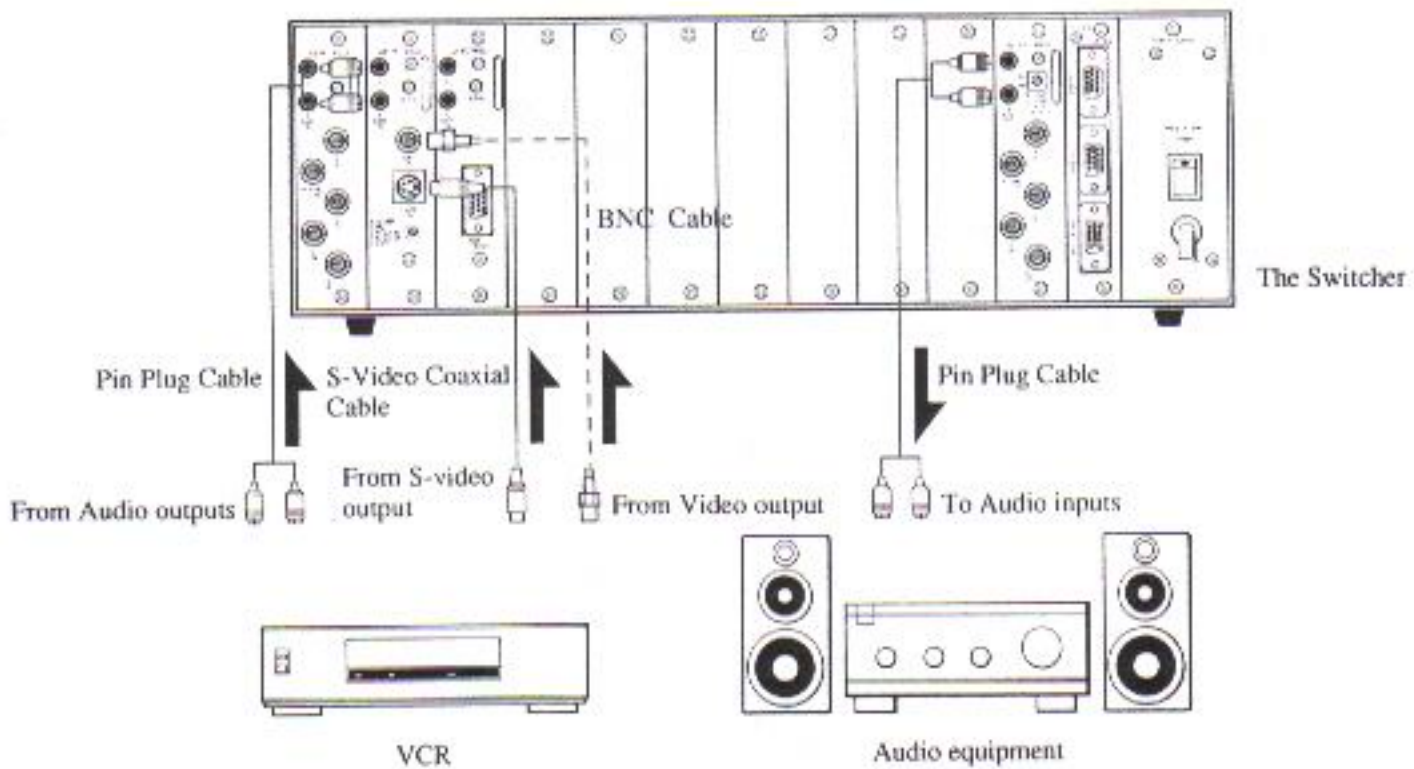

-  shows signal flow.
- For more information on the VCR and audio equipment, refer to the user's manual accompanying them.
- Cables are not included with the Switcher.

Connecting with a Document Camera and a Monitor

The signal from a document camera output to the monitor.

RGB INPUT MODULE

- RGB INPUT MODULE is optional (6010-RGB).

RGB OUTPUT MODULE

- EQ switch and H/SYNC select switch should be set according to the mode and the equipment to be used.
(Refer to page 12.)

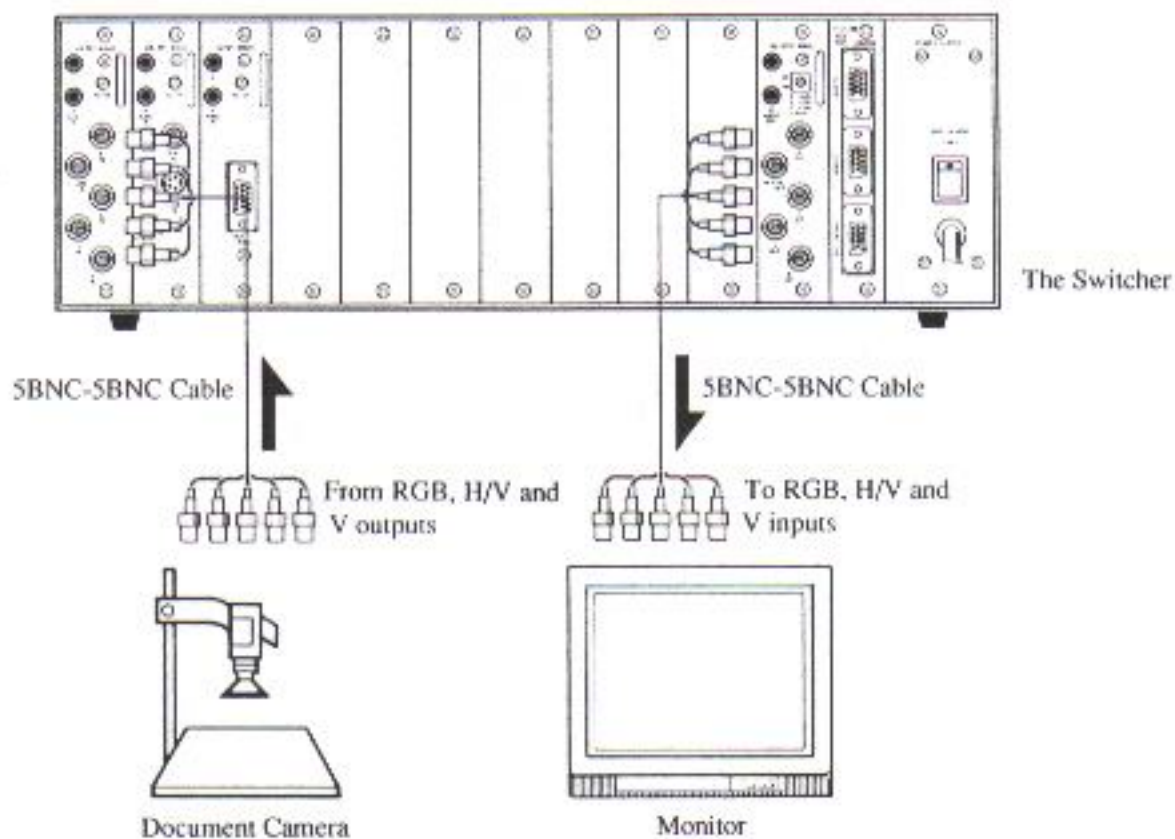

-  shows signal flow.
- For more information on the document camera and the monitor, refer to the user's manual accompanying them.
- Cables are not included with the Switcher.

D-SUB 15 PIN TERMINALS

EXT CONTROL Terminal

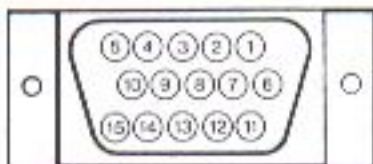

Mini D-SUB 15 pin

Use this terminal when controlling the Switcher from an external control such as a console.

Function	Pin No.	14 and 15
External Control ON		SHORT
External Control OFF		OPEN

Function	Pin No.	5 and 15
POWER ON		SHORT
POWER OFF		OPEN

Function	Pin No.	8 and 15	3 and 15	9 and 15	4 and 15
SLOT 1		SHORT	SHORT	SHORT	SHORT
SLOT 2		OPEN	SHORT	SHORT	SHORT
SLOT 3		SHORT	OPEN	SHORT	SHORT
SLOT 4		OPEN	OPEN	SHORT	SHORT
SLOT 5		SHORT	SHORT	OPEN	SHORT
SLOT 6		OPEN	SHORT	OPEN	SHORT
SLOT 7		SHORT	OPEN	OPEN	SHORT
SLOT 8		OPEN	OPEN	OPEN	SHORT
SLOT 9		SHORT	SHORT	SHORT	OPEN
SLOT 10		OPEN	SHORT	SHORT	OPEN

Function	Pin No.	10 and 15
PICTURE MUTE ON		SHORT
PICTURE MUTE OFF		OPEN

Function	Pin No.	12 and 15
SOUND MUTE ON		SHORT
SOUND MUTE OFF		OPEN

- Pin 13 is the external remote signal terminal for expansion. The Switcher can be controlled by the same format signal from the remote control. The remote control is optional in stand alone applications.
- Pin 14 is the ENABLE terminal for the external control. When using the EXT CONTROL terminal, be sure to set pins 14 and 15 to the SHORT position.
- Pin 15 is ground.
- Pins 1, 2, 6, 7 and 11 are terminals for expansion. Set them to the OPEN positions constantly.
- POWER on/off, input selection(slot selection), PICTURE MUTE and SOUND MUTE functions will not operate with the controls on the front panel and the remote control when in the External Control mode. The remote control is optional in stand alone applications.

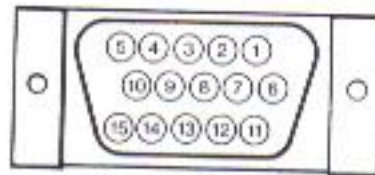
REMOTE 1 and 2 Terminals

Mini D-SUB 15 pin

REMOTE 1 Terminal

- Use the REMOTE 1 terminal when connecting to the projector.
- When the projector is used, connect it with the optional control cable (15pin-15pin; 50ft./16m; CTL-6010) to this REMOTE 1 terminal.

Pin No.	I/O	Signal Name	Function
1	I	Receive Data +	Receiving data when using Projector
6	I	Receive Data -	
2	O	Transmit Data +	Sending data when using Projector
7	O	Transmit Data -	
11	I	Clear to Send +	Clearing to send when using Projector
12	I	Clear to Send -	
3	O	Request to Send +	Requesting to send when using Projector
8	O	Request to Send -	
9	I		Used inside the Switcher
4, 5, 10, 13, 14		Non Connected	Not used
15		Signal Ground	Ground

REMOTE 2 Terminal

- Use the REMOTE 2 terminal when connecting to a personal computer and other control units.

Pin No.	I/O	Signal Name	Function
1	O	Transmit Data +	Sending data when using PC
6	O	Transmit Data -	
2	I	Receive Data +	Receiving data when using PC
7	I	Receive Data -	
11	O	Request to Send +	Requesting to send when using PC
12	O	Request to Send -	
3	I	Clear to Send +	Clearing to send when using PC
8	I	Clear to Send -	
9	O		Used inside the Switcher
4, 5, 10, 13, 14		Non Connected	Not used
15		Signal Ground	Ground

NOTE: The communication mode of the REMOTE 2 terminal can be selected between RS-422 and RS-232C. Consult your dealer for selecting.

When using RS-232C, only pins 6, 7, 8, and 12 are effected. Therefore, nothing should be connected to pins 1, 2, 3 and 11.

D-SUB 15 PIN TERMINALS

Connection Examples for Personal Computer Control for the 3 Variations.

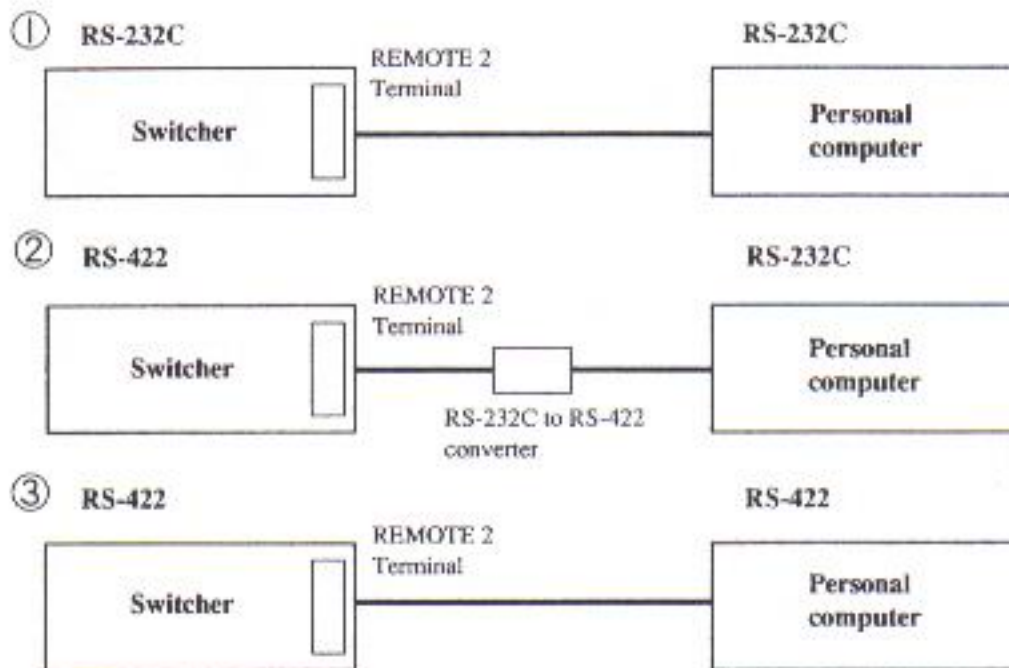

① When using the REMOTE 2 terminal as RS-232C:

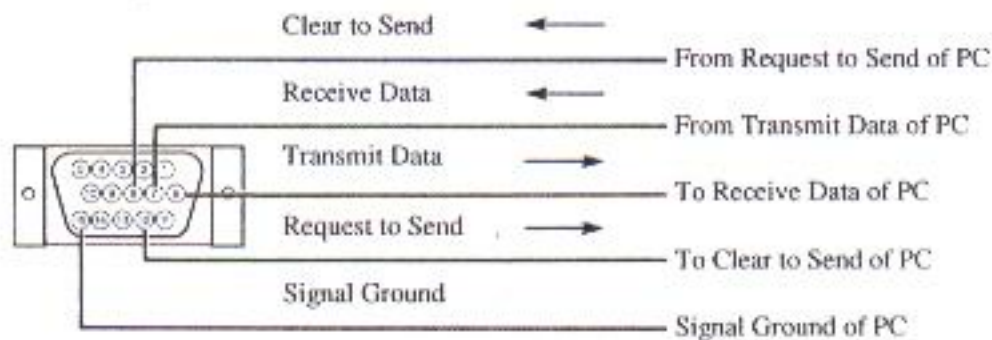

② ③ When using the REMOTE 2 terminal as RS-422:

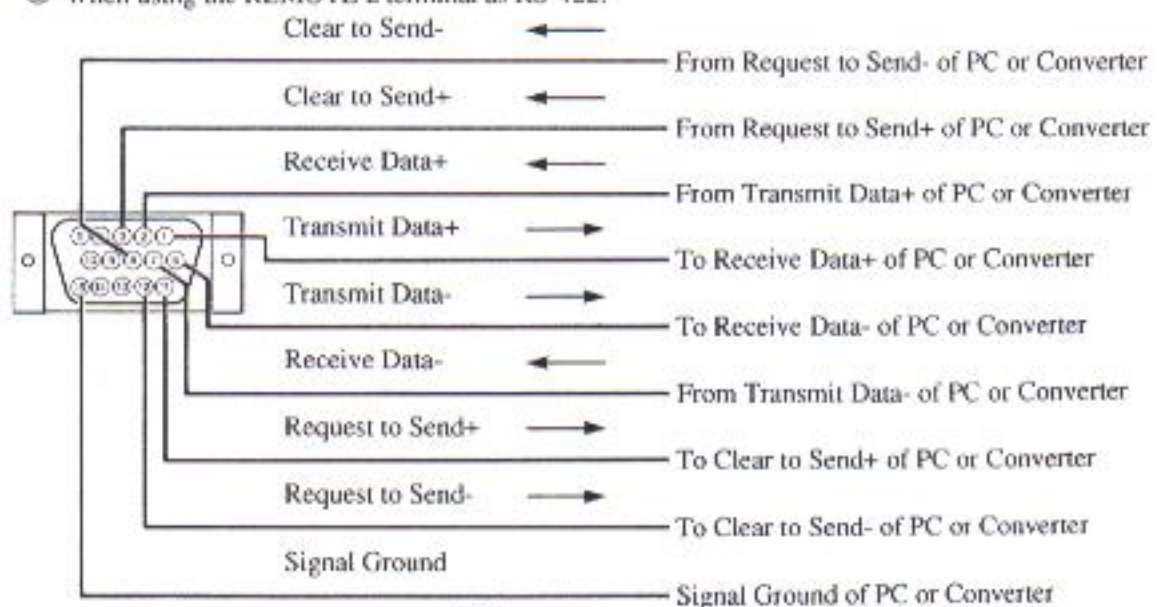

INSTALLATION

Module Installation

NOTE: Unplug the Switcher from the power outlet before installing or removing a module.

When removing the module from the Switcher, do not touch the inside other than service switches.

Do not subject a module to electrical or static shocks.

Do not attempt to service the Switcher yourself as opening may expose you to dangerous voltage potentials and risk of electric shock. Refer all servicing to qualified service personnel.

- ① Loosen the upper and lower screws and remove the panel.



- ② Slide the module along the guide rail into a slot. Make sure the module board is seated in the slot correctly.

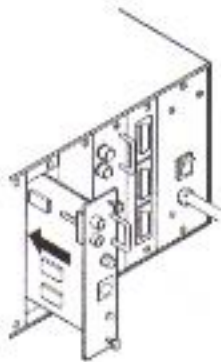

- ③ Secure the two screws.

NOTE: First secure the upper screw.



Rack Mounting

For safety, use only the supplied rack mounting kit when installing the Switcher in a rack.

NOTE: Please follow EIA standards (3U) when using a rack.

- ① Remove six screws A from the Switcher.
- ② Secure the rack mount brackets B to the Switcher with the screws A (6 pieces) removed in step 1 above.

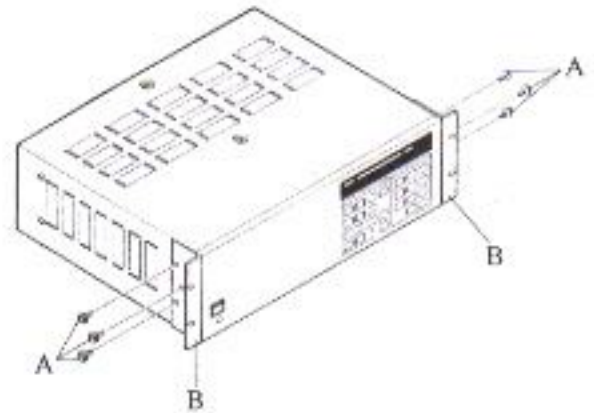

- ③ Attach the Switcher to EIA standard rack and secure with screws.

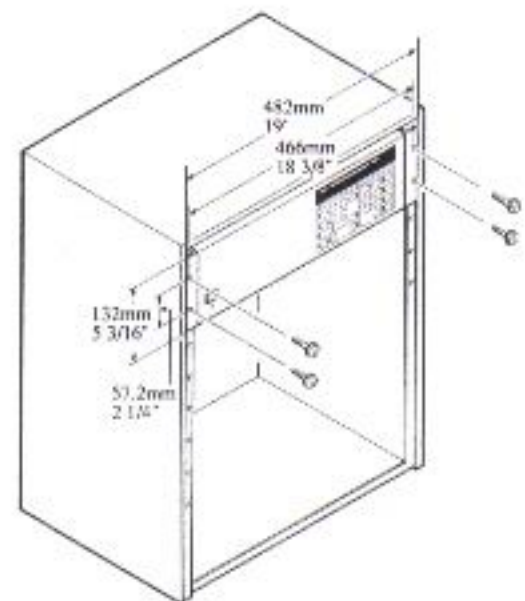

SPECIFICATIONS

Input (OPTION) : Max 10 inputs

VIDEO INPUT module	: Video	1.0 Vp-p 75 ohm positive (BNC) or switchable
	S-Video	Y 1.0 Vp-p 75 ohm positive C 0.28 Vp-p 75 ohm (burst level)
	AUDIO	2ch 0.4 Vrms 47K ohm (RCA)
RGB INPUT module	: RGB signal	0.7 Vp-p 75 ohm positive (BNC)
	HV sync	0.7 ~ 4.0 Vp-p 1K ohm Negative or positive (BNC)
	MIX sync	0.7 ~ 4.0 Vp-p 1K ohm Negative or positive (BNC)
	G sync	0.3 ~ 0.6 Vp-p 75 ohm Negative (BNC)
	AUDIO	2ch 0.4 Vrms 47K ohm (RCA)
VGA INPUT module	: IBM VGA compatible (D-SUB 15PIN)	
	AUDIO	2ch 0.4 Vrms 47 K ohm (RCA)

Output : Standard 1, Max. 4

RGB OUTPUT module	: RGB signal	0.7 Vp-p 75 ohm positive (BNC)
	HV sync	0.7 ~ 2.0 Vp-p 75 ohm Negative or positive (BNC)
	MIX sync	0.7 ~ 2.0 Vp-p 75 ohm Negative or positive (BNC)
	G sync	0.3 ~ 0.6 Vp-p 75 ohm Negative (BNC)
	Audio	2ch 0.4 Vrms 1K ohm (RCA)
Video bandwidth	: 100MHz (± 3dB)	
Power supply	: AC 120V, 60Hz (ISS-6010) AC 220/240V, 50Hz (ISS-6010G)	
Power consumption	: 0.85A (ISS-6010) 0.54A (ISS-6010G)	
Safety and regulation	ISS-6010 : UL Meet UL 1950 IEC Governed by IEC 950 FCC Meet FCC class A CSA certified	
	ISS-6010G : TÜV Meet TÜV regulations IEC Governed by IEC 950 FTZ Meet FTZ class B	
Cabinet dimension	: 430(W)×340(D)×132(H) mm 16-15/16(W)×13-6/16(D)×5-3/16(H) inch	
Weight	: 7.5 Kg/ 16.6 lbs	
Main control function	: Power ON/OFF, Input signal select, RGB gain, Audio level, Color, Tint, Sharpness, Picture mute, Audio mute, Store, Normalize	
External control	: Power ON/OFF, Input signal select, Picture mute, Audio mute	
Supplied accessories	: Rack mount kit, QUAD DECODER mount brackets, User's manual	
Environment	: Temperature 0 to 40 degrees C Humidity 0 to 90% non-condensing Storage -10 to 50 degrees C	

※Specifications are subject to change without notice.

Command Reference

STAND ALONE MODE

PC Control

Contents

Power ON	24
Power OFF	
R - GAIN	
G - GAIN	
B - GAIN	
CONTRAST	
AUDIO	
SHARPNESS	
COLOR	
TINT	
UP	
DOWN	
Input Select	
Picture Mute ON	
Picture Mute OFF	
Audio Mute ON	25
Audio Mute OFF	
Store	
Normal	
Load	
E ² ROM UP LOAD	
E ² ROM DOWN LOAD	

APPENDIX

Power ON

[PC → Switcher]
BFH, 20H, 08H, 00H, CKS

[Switcher → PC] ACK
1FH, 20H, 08H, 00H, CKS

- ACK
- Internal Power ON processing

Power OFF

[PC → Switcher]
BFH, 20H, 88H, 00H, CKS

[Switcher → PC] ACK
1FH, 20H, 88H, 00H, CKS

- ACK
- Internal Power OFF processing

R - GAIN

[PC → Switcher]
BFH, 20H, 30H, 00H, CKS

[Switcher → PC] ACK
1FH, 20H, 30H, 00H, CKS

- ACK
- R - GAIN selection

G - GAIN

[PC → Switcher]
BFH, 20H, 31H, 00H, CKS

[Switcher → PC] ACK
1FH, 20H, 31H, 00H, CKS

- ACK
- G - GAIN selection

B - GAIN

[PC → Switcher]
BFH, 20H, 32H, 00H, CKS

[Switcher → PC] ACK
1FH, 20H, 32H, 00H, CKS

- ACK
- B - GAIN selection

CONTRAST

[PC → Switcher]
BFH, 20H, 37H, 00H, CKS

[Switcher → PC] ACK
1FH, 20H, 37H, 00H, CKS

- ACK
- CONTRAST selection

AUDIO

[PC → Switcher]
BFH, 20H, 06H, 00H, CKS

[Switcher → PC] ACK
1FH, 20H, 06H, 00H, CKS

- ACK
- AUDIO selection

SHARPNESS

[PC → Switcher]
BFH, 20H, 35H, 00H, CKS

[Switcher → PC] ACK
1FH, 20H, 35H, 00H, CKS

- ACK
- SHARPNESS selection

COLOR

[PC → Switcher]
BFH, 20H, 33H, 00H, CKS

[Switcher → PC] ACK
1FH, 20H, 33H, 00H, CKS

- ACK
- COLOR selection

TINT

[PC → Switcher]
BFH, 20H, 34H, 00H, CKS

[Switcher → PC] ACK
1FH, 20H, 34H, 00H, CKS

- ACK
- TINT selection

UP

[PC → Switcher]
BFH, 20H, 0CH, 00H, CKS

[Switcher → PC] ACK
1FH, 20H, 0CH, 00H, CKS

- ACK
- UP processing

DOWN

[PC → Switcher]
BFH, 20H, 0DH, 00H, CKS

[Switcher → PC] ACK
1FH, 20H, 0DH, 00H, CKS

- ACK
- DOWN processing

Input Select

[PC → Switcher]
BFH, 20H, INPUT SW*, 00H, CKS
★ INPUT SW=10 ~19H

[Switcher → PC] ACK
1FH, 20H, INPUT SW, 00H, CKS

- ACK
- INPUT SW switchover

Picture Mute ON

[PC → Switcher]
BFH, 20H, 07H, 00H, CKS

[Switcher → PC] ACK
1FH, 20H, 07H, 00H, CKS

- ACK
- Picture Mute ON

Picture Mute OFF

[PC → Switcher]
BFH, 20H, 87H, 00H, CKS

[Switcher → PC]
1FH, 20H, 87H, 00H, CKS

- ACK
- Picture Mute OFF (release)

Audio Mute ON

[PC → Switcher]
BFH, 20H, 09H, 00H, CKS

[Switcher → PC] ACK
1FH, 20H, 09H, 00H, CKS

- ACK
- Audio Mute ON

Audio Mute OFF

[PC → Switcher]
BFH, 20H, 89H, 00H, CKS

[Switcher → PC] ACK
1FH, 20H, 89H, 00H, CKS

- ACK
- Audio Mute OFF (release)

STORE

[PC → Switcher]
BFH, 20H, 4FH, 00H, CKS

[Switcher → PC] ACK
1FH, 20H, 4FH, 00H, CKS

- GAIN DATA E²ROM STORE
- ACK

NORMAL

[PC → Switcher]
BFH, 20H, 05H, 00H, CKS

[Switcher → PC] ACK
1FH, 20H, 05H, 00H, CKS

- NORMAL DATA D/A output
- ACK

LOAD

[PC → Switcher]
BFH, 20H, 4BH, 00H, CKS

[Switcher → PC] ACK
1FH, 20H, 4BH, 00H, CKS

- E²ROM DATA D/A output
- ACK

E²ROM UP LOAD

[PC → Switcher]
FFH, 20H, 50H, 01H, BUNK CODE*, CKS
★ BUNK CODE 00H → 00H(E²ROM ADDRESS)
01H → 40H
02H → 80H
03H → C0H

[Switcher → PC] ACK
DFH, 20H, 50H, 81H(129Byte), BUNK CODE,
Data, CKS

- DATA from E²ROM Read ----- about 90msec
- ACK ----- about 200msec

E²ROM DOWN LOAD

[PC → Switcher]
FFH, 20H, 51H, 81H(129Byte), BUNK CODE*,
Data, CKS
★ BUNK CODE 00H → 00H(E²ROM ADDRESS)
01H → 40H
02H → 80H
03H → C0H

[Switcher → PC]
(ACK)
1FH, 20H, 51H, 01H, BUNK CODE, CKS
(NAK)
9FH, 20H, 51H, 01H, BUNK CODE, CKS

- Received DATA → E²ROM Write
----- about 450msec
- Write OK → ACK
- Write NG → NAK

You can control the main functions from external equipment such as personal computer using the REMOTE 2 terminal. The following sections explain the interface.

Interface Condition

- RS-232C or RS-422
- Baud rate.....9600 bps
- Data length.....8 bits
- Parity.....Odd parity
- Stop bit.....1 bit
- Communications mode.....Full duplex

Control Data Format

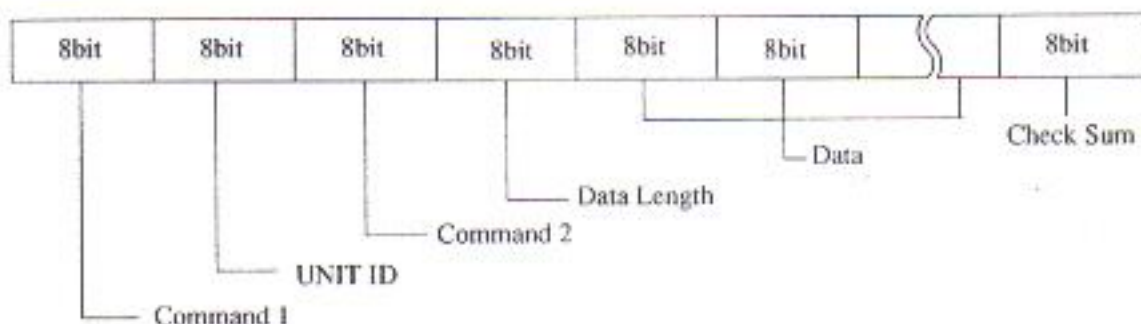

- Command 1 Code based on the command system
- UNIT ID Code allocated to each equipment(Allocate 20H to the Switcher)
- Command 2 Code allocated to the main functions of the Switcher
- Data Length Number of bytes of the data that is transmitted
- Data Data that is transmitted
- Check Sum Lower eight digits of sum total of the first byte to the byte just before the last

Command Communication Sequence

When a personal computer gives the command to the Switcher, the Switcher returns an ACK or NAK. So make sure that the external equipment receives this ACK or NAK.

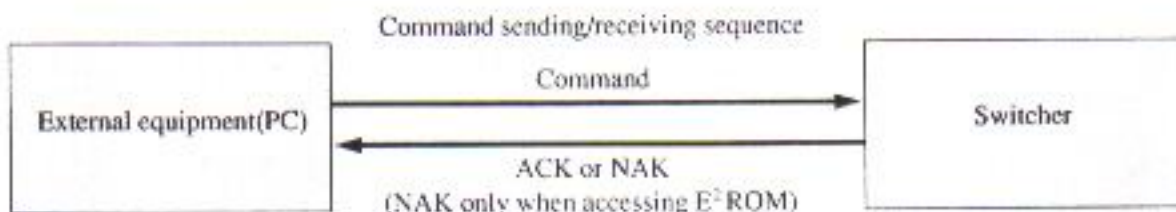

The Switcher returns an ACK if it has received the command correctly. If it has not received the command correctly due to data error, it will not return a NAK. Therefore, when the external equipment send a command, make sure that it receives the ACK. The Switcher returns a NAK only when a WRITE error has occurred during E²ROM access commands.

E² ROM Access Commands

You can access up to 256 words of E²ROM which is divided into the 4 banks.

The data stored in the Switcher is allocated as shown below.

Be sure not to rewrite the data in A0H through FFH address areas because they are used inside the Switcher.

E² ROM Memory Map

00H	INPUT SELECT 1
10H	INPUT SELECT 2
20H	INPUT SELECT 3
30H	INPUT SELECT 4
40H	INPUT SELECT 5
50H	INPUT SELECT 6
60H	INPUT SELECT 7
70H	INPUT SELECT 8
80H	INPUT SELECT 9
90H	INPUT SELECT 10
A0H	
B0H	
C0H	
D0H	
E0H	
F0H	
FFH	



Configuration of one entry data

+00H	Mode 1	D15	D8	D7	D0
+04H	Mode 2				
+08H	Mode 3	+00H	RED	GREEN	
+0CH	Mode 4	+01H	BLUE	COLOR	
		+02H	TINT	SHARPNESS	
		+03H	AUDIO		

The 4 memory areas are reserved for each Input Slot of the Switcher.
Use the memory area according to the input video signal as follows:

NTSC 3.58	Area of mode 1
NTSC 4.43	Area of mode 2
PAL	Area of mode 3
SECAM	Area of mode 4
RGB	Area of mode 4

