

Service Manual

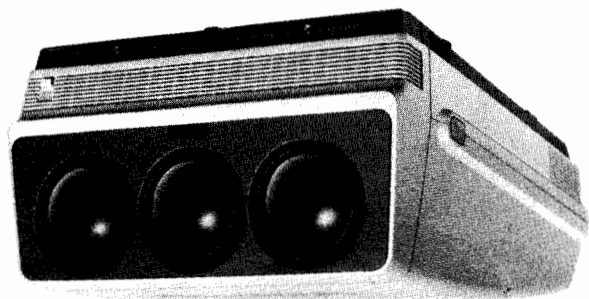

Color Projection System

PT-M1085U PT-M1083U

Chassis No. S4

The service technician is required to read and follow the "Safety Precautions" and "Important Safety Notice" in this service manual.

Specifications

Power supply:

AC 120 V, 50/60 Hz

Power consumption:

PT-M1085U: 470 W

PT-M1083U: 430 W

(9 W during remote control standby)

MAX Amps:

PT-M1085U: 5.9 A

PT-M1083U: 5.4 A

Picture tube:

7-inch liquid cooled high-brightness electrostatic focusing tube×3

Lenses:

F1.03 hybrid lens×3

(with red and green color lenses)

Luminous output:

850 lumens at peak output

Resolution:

1,600×1,280 dots (PT-M1085U)

1,500×1,200 dots (PT-M1083U)

Video band:

90 MHz (PT-M1085U)

75 MHz (PT-M1083U)

Horizontal scanning frequency:

15~100 kHz (PT-M1085U)

15~70 kHz (PT-M1083U)

Vertical scanning frequency:

38~150 Hz

Data memory capacity:

RGB signals: 16 addresses×3 modes

LINE signals: 2 addresses×3 modes

S-VIDEO signals: 2 addresses×3 modes

Projection size at shipment:

120 inches (ceiling type)

Power cord length:

8.2 feet (2.5 m)

Weight:

136.4 pounds (62 kg)

Dimensions:

Width: 25 inches (637 mm)

Height: 14⁴/₅ inches (376 mm)Depth: 32¹/₆ inches (817 mm)**Ambient conditions:**

Temperature: 23°F~104°F (-5~40°C)

Humidity: 20~80%

Connection terminals:

Analog RGB IN 1 terminals

(BNC×5):

R, G, B 0.7 Vp-p 75 Ω

G. SYNC 1.0 Vp-p 75 Ω

H/H.V 0.3~5.0 V High impedance

V 0.3~5.0 V High impedance

Analog RGB IN 2 terminal (D-SUB 15 pin)

VGA-compliant

LINE IN/OUT terminals (BNC×2):

1.0 Vp-p, 75 Ω or high impedance

Panasonic®

© 1995 Matsushita Electric Industrial Co., Ltd.
All rights reserved. Unauthorized copying and
distribution is a violation of law.

△ WARNING

This service information is designed for experienced repair technicians only and is not designed for use by the general public. It does not contain warnings or cautions to advise non-technical individuals of potential dangers in attempting to service a product. Products powered by electricity should be serviced or repaired only by experienced professional technicians. Any attempt to service or repair the product or products dealt with in this service information by anyone else could result in serious injury or death.

S-VIDEO terminal (MINI DIN 4-pin (lock type)):

Y signal 1.0 Vp-p, positive polarity
(with negative sync signal) 75 Ω

C signal 0.286 Vp-p

AUDIO IN/OUT terminals (Stereo Phono jack × 4):

0.5 Vrms 33 kΩ or higher

REMOTE IN 1 connector (D-SUB 9 pin):

For external control

REMOTE IN 2 connector (D-SUB 15 pin):

For adjustment and maintenance

REMOTE 3 IN/OUT terminals (M3 plug):

For connecting the remote control and for serial operation

SIGNAL SELECTOR connector (D-SUB 15 pin):

For connecting a signal selector (for future use)

Internal test signals:

7 signals

(crosshatch, crosshair, dot, H character, window, full white, pluge)

Convergence:

Digital control, separate 21-zone adjustment

Accessories:

Remote control unit: 1 pc.

Power supply: DC 3 V (for AA-size batteries)

Operation range:

Approx. 39.7 feet (12 m) without cable
connected (from directly in front of receptor)

Approx. 49.2 feet (15 m) with cable connected

Weight: Approx. 0.77 pounds (350 g)
(with batteries)

Dimensions: Width: 5 1/2 inches (140 mm)

Height: 1 2/5 inches (36 mm)

Length: 7 1/8 inches (181 mm)

AA-size batteries: 4 pcs.

Remote control cable: 1 pc.

(Approx. 49.2 feet [15 m])

Remote control strap: 1 pc.

Power cord: 1 pc. (8.2 feet [2.5 m])

Lens caps: 3 pcs.

Lens spacer: 70-inch/Front 3 pcs.

200-inch/Front 3 pcs.

70-inch/Rear 3 pcs.

100-inch/Rear 3 pcs.

200-inch/Rear 3 pcs.

S-VIDEO/BNC conversion adapters: 2 pcs.

Optional accessory:

Mounting kit ET-PK180

CONTENTS

SAFETY PRECAUTION	1
X-RADIATION	2
CIRCUIT EXPLANATION	5
LOCATION OF EACH PROJECTOR PART	7
LOCATION OF EACH REMOTE CONTROL PART	9
SYSTEM CONFIGURATION EXAMPLES	13
DISASSEMBLY INSTRUCTIONS	18
SELF-DIAGNOSIS FUNCTIONS	26
MEASUREMENTS AND ADJUSTMENTS	29
CIRCUIT BOARDS	97
BLOCK DIAGRAMS	145
TERMINAL GUIDE OF ICs and TRANSISTORS	153
SCHEMATIC DIAGRAMS	154
EXPLODED VIEWS	244
REPLACEMENT PARTS LIST	253

- THESE MODELS COMPLY WITH DHHS RULES 21 CFR SUBCHAPTER J APPLICABLE AT DATE OF MANUFACTURE.

IMPORTANT SAFETY NOTICE

There are special components used in Panasonic Color Video/Data projector which are important for safety. These parts are shaded on the schematic diagram. It is essential that these critical parts should be replaced with manufacturer's specified parts to prevent X-RADIATION, shock, fire, or other hazards. Do not modify the original design without permission of PANASONIC BROADCAST & TELEVISION SYSTEMS COMPANY.

PRECAUTION: To prevent permanent burning of the picture tubes do not operate the projector with a still picture for an extended time period when not necessary and be certain to turn power off when not in use.
Burned picture tubes are not covered under warranty.

SAFETY PRECAUTION

GENERAL GUIDELINES

1. It is advisable to use an isolation transformer in the AC line supply before servicing this model.
2. When servicing observe the original lead dress, especially in the high voltage circuit. In case of a short circuit, replace every part which has overheated.
3. After servicing observe that all protective devices such as insulation barriers, fish paper, shields, isolation networks and fuses are properly installed.
4. Before turning the receiver on, the resistance between the B+ line and chassis ground should be checked. Connect the \ominus side of an ohmmeter to the B+ lines and the \oplus side to chassis ground.
Each line should have more resistance than specified, as shown in Table 1:
5. If the set is not intended to be used for a long time, the power cord should be unplugged from the AC line outlet.
6. Potentials, as high as 34.3kV are present when this set is in operation. Removal of the covers involves the danger of a shock hazard from the set's power supply. Servicing should not be attempted by anyone who is not thoroughly familiar with the precautions necessary when working on high-voltage equipment.
Always discharge the anode of the projection tube to the set chassis before handling the tube.
7. After servicing, make the leakage current checks to prevent a shock hazard.

K-P.C. Board	
B+ Line	Minimum Resistance
12V (TPK1)	300 Ω
5.6V (TPK2)	180 Ω
P-P.C. Board	
B+ Line	Minimum Resistance
160V (TP104)	67k Ω
14V (R9124)	1k Ω
198V (TP204)	20k Ω
18V (TP206)	180 Ω
8.4V (TP207)	270 Ω
115.5V (TP304)	75 Ω
17V (TP305)	1k Ω
35.5V (TP306)	200 Ω
B- Line (*)	Minimum Resistance
-8.8V (TP205)	370 Ω
-18V (TP208)	80 Ω
-36.5V (TP307)	1k Ω
-17.5V (TP308)	1k Ω

*: Connect the \oplus side of an ohmmeter to the B- line and the \ominus side to chassis ground.

Table 1

LEAKAGE CURRENT COLD CHECK

1. Unplug the AC cord and connect a jumper between the two plug prongs.
2. Turn on the set.
3. Measure the resistance value with an ohmmeter between the jumpered AC plug and each exposed metallic part such as screwheads, input terminals, control shafts, etc.

When the exposed metallic part has a return path to the chassis, the reading should be between $490k\Omega$ and $9M\Omega$. When the exposed metal does not have a return path to the chassis, the reading must be infinite.

LEAKAGE CURRENT HOT CHECK (See Fig. 1)

1. Plug the AC cord directly into the AC outlet. Do not use an isolation transformer during this check.
2. Connect a $1.5k\Omega$, 10 watts resistor, in parallel with a $0.15\mu F$ capacitor between each exposed metallic part and an ground. Use a good ground, for example, a water pipe.
3. Use a high impedance AC voltage meter (VTVM) to measure the potential across the resistor.
4. Move the resistor connection to each exposed metallic part and measure the voltage present.
5. Check that any potential does not exceed 0.75 volt RMS. A leakage current tester (Simposon Model 229 or equivalent) may be used in the above hot check, in which case any current measured must not exceed 1/2 milliamp. In case any measurement is out of the limits specified, there is a possibility of a shock hazard and the set should be repaired and rechecked before it is returned to the customer.

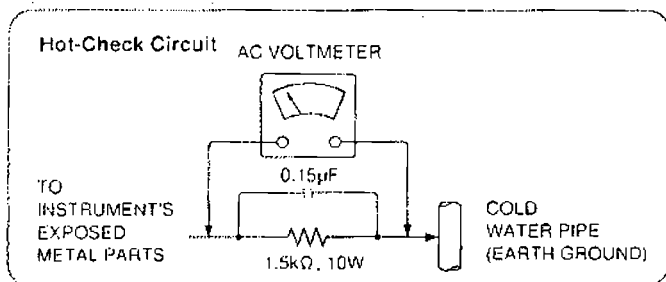

Fig. 1

X-RADIATION

WARNING: The potential source of X-Radiation in the color video projector is the High voltage section and the projection tubes.

NOTE: It is important to use an accurate, periodically, calibrated high voltage meter.

1. Set to the bright mode by using menu selector button on the projector.
Minimize Brightness by using control level adjustment button.
2. Measure the High Voltage. The high voltage meter should indicate $32kV\pm 0.5kV$. If the upper meter indication is out of tolerance, immediate service and correction is required to prevent the possibility of premature component failure. (Refer to high voltage adjustment in the manual.)
3. To prevent an X-Radiation possibility, it is essential to use the specified projection tube only.
4. To prevent exposure to X-Radiation, the projection tube shield must be kept in place with power applied to the set.

WARNING: When using a projection tube test jig for service, ensure that jig is capable of handling $32.5kV$ without causing X-Radiation.

HORIZONTAL OSC. DISABLE CIRCUIT TEST

This test must be made as a final check before the set is returned to the customer.

1. With the chassis case removed, supply a nominal 120V AC to the set, turn on the set.
2. Set the customer controls to normal operating positions.
3. Press the TEST button once on the remote control and display internal crosshatch of NTSC sync.
4. Short the C6046 with a jumper wire.
5. Short the R6068 with a jumper wire.
Confirm vanish the high voltage, and reaster stop, and $120V\pm 10V$ on the voltmeter.
6. If this does not occur, the Horizontal Osc. Disable Circuit is not operating. Follow the Horizontal Osc. Disable Circuit Repair Procedures before the set is returned to the customer.

REPAIR PROCEDURES OF THE HORIZONTAL OSCILLATOR DISABLE CIRCUIT (Fig. 2)

1. Connect a DC voltage between capacitor C6040 (⊕) on the E-P.C. board and chassis ground. If nearly 23V is not present on that point find the cause. Check R6069, D6022, C6040, R6068, R6066 and R6067.
2. Connect the + side of DC voltmeter to collector of Q6025 and the - side to TPE5 (GND). The collector of Q6025 potential varies from nearly 11V to nearly 0.1V when shorting R6068. If this does not occur, check C6038, C6037, Q6020, R6063, D6024, R6060, Q6021, R6062, R6064,

D6025, C6042, R6065, D6028, R6078, D6027, C6043, Q6022, R6071, R6073, R6072, C6044, Q6023, Q6024, D6026, R6070, D6029, R6074, R6075, C6045, R6061, and Q6025.

3. Carefully check above specified parts related circuits and parts. When the circuit is repaired, try the Horizontal Oscillator Disable Test again.
4. In case that at least one of R6066, R6067, R6068, D6024 and FBT is replaced, follow Adjustment Procedure of Horizontal Oscillator Disable Circuit as follows.

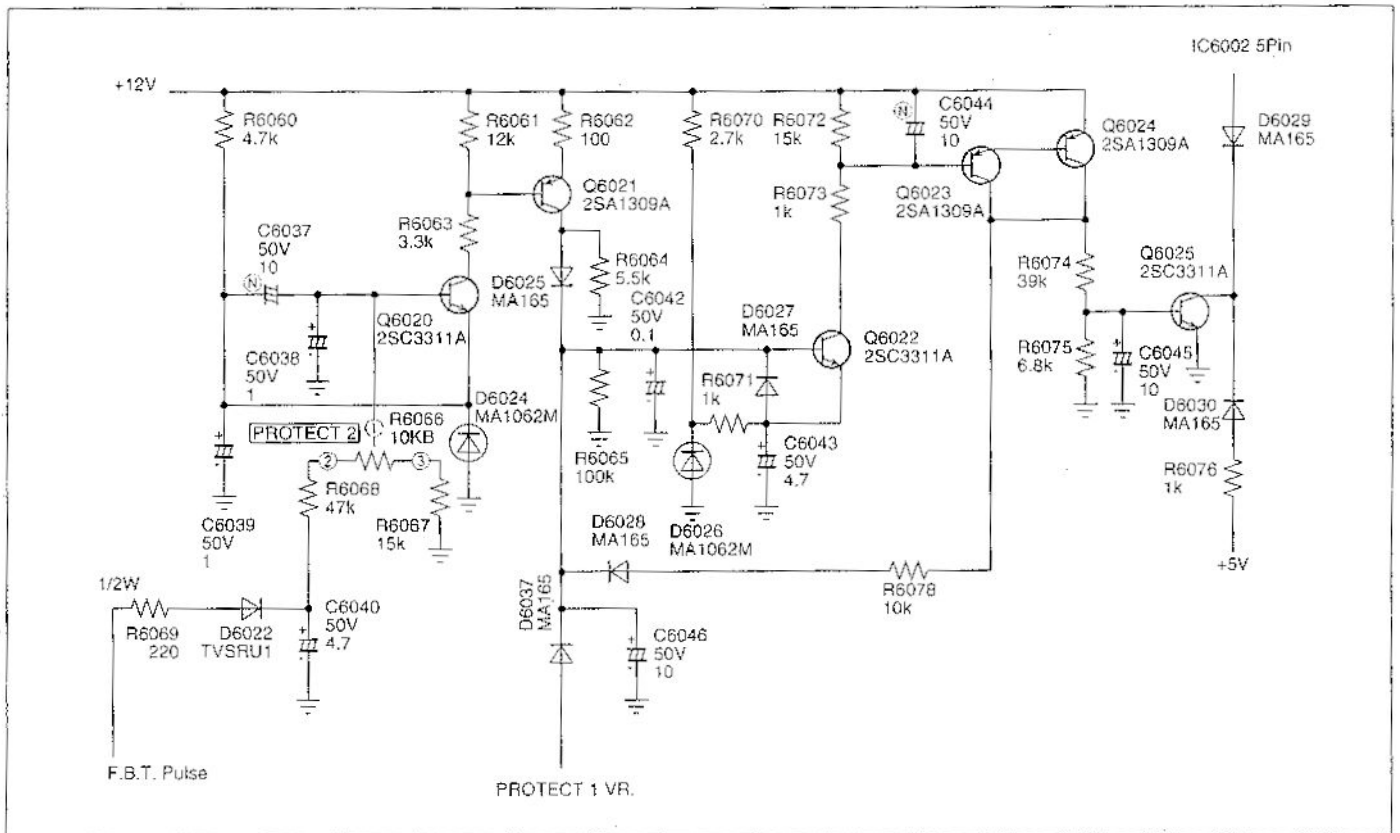

Fig. 2

ADJUSTMENT PROCEDURE OF THE HORIZONTAL OSCILLATOR DISABLE CIRCUIT

Replace R6066 (Protector 2 Adj.) and R6045 (HV Adj.) before this adjustment. R6066 (Protector 2 Adj.) and R6045 (HV Adj.) are manufactures specified parts only.

1. Set the following controls at the positions indicated.
 Input Signal Selector SW (S7408).....LINE
 R6045 (HV Adj.)Fully Counter-clockwise
 R6066 (Protector 2 Adj.)Fully Counter-clockwise
 Connect the + (positive) side of DC voltmeter to TPE1 and - (negative) side to TPE2 on E-P.C. board.
2. Connect the high voltage meter to anode lead of the distributor as shown in Fig. 3.

3. Turn on the Power Switch, and receive a window pattern signal.
4. Connect a short jumper between TPE6 and TEP5 and C6046 both side.
5. Adjust R6045 (HV Adj.) the Brightness control and the Contrast control to obtain (34kV±0.3kV) on the high voltage meter, and obtain (1.9V±0.1V) on the voltage meter.

CAUTION:

Use only a Static Type of High Voltage Meter which has a 5% tolerance at 40kV.

DISCONNECTION OF ANODE LEAD FROM THE DISTRIBUTOR AND CONNECTION OF HIGH VOLTAGE METER

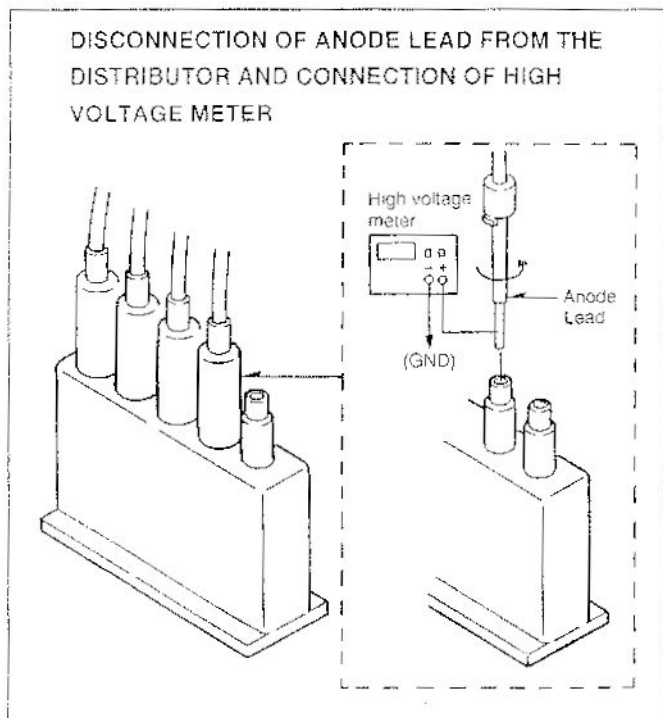

Fig. 3

6. Adjust R6066 (Protector 2 Adj.) slowly clockwise until shut-down occurs and hold that position.
7. Turn off the power switch.
8. Adjust R6045 (HV Adj.) slightly counter-clockwise.
9. Turn on the power switch.
10. Adjust R6045 (HV Adj.) slowly clockwise until shut-down occurs. High Voltage should be $34\text{kV} \pm 0.5\text{kV}$, and $1.9\text{V} \pm 0.1\text{V}$ on the voltage meter just before shut-down.
11. If the readings in step 10 are not confirmed, repeat steps 5 to 10.
12. Turn off the power switch.
13. Disconnect the short jumper between TPE6 and TPE5, and C6046 both sides.
14. Turn on the power switch, and adjust that the high voltage is $32.0\text{kV} \pm 0.5\text{kV}$ with R6045.
15. Confirm that the high voltage does not change by turning the Brightness and Contrast controls.
16. Fix R6066 (Protector 2 Adj.) and R6045 (HV Adj.) with bond as illustrated below. (Fig. 4)

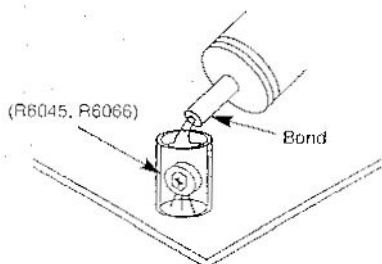

Fig. 4

X-RAY PRECAUTIONS

The front area (between the projection tube and the lens) is enclosed by a metal box to ensure positive safety during abnormal and normal conditions when checking and doing repair work. To fully ensure safety, however, the following precautions must be observed.

- (1) Do not remove the lens.
- (2) Be sure to turn OFF the power when the lens must be removed and when you could be exposed to X-rays during cleaning and other routine servicing.
- (3) Do not remove the lens to check the projection tube for operation by watching it directly.
- (4) Do not remove the LEAD TAPE on the CRTs. (Fig. 5)
- (5) Do not remove the METAL COVER on the CRTs. (Fig. 5)
- (6) Do not remove the LEAD TAPE LENSES. (Fig. 5)

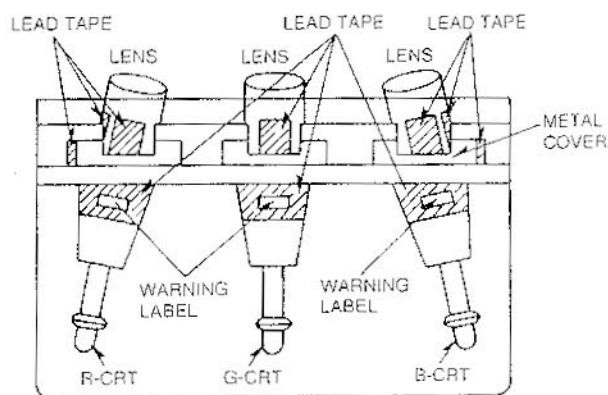

Fig. 5

CIRCUIT EXPLANATION

1. Horizontal Oscillator Disable Circuit (See Fig. 6)

For maximum security, this Panasonic Color Projection System has Horizontal Oscillator Disable Circuit which prevent an excessive X-Radiation possibility.

To monitor the high voltage, the positive DC voltage from the cathodes of D6022 is applied through R6068, R6066 to the base of Q6020.

Under normal conditions, this voltage is insufficient to cause Q6020 to conduct. If the high voltage increases over the specified voltage in the worst case, the voltage at the base of Q6020 increases, and causes Q6020 to conduct, thus lowering the potential at its collector. This lowered collector potential is applied to the base of Q6021 through R6063 causing it to conduct. The voltage at the collector of Q6021 increases. This increased potential is applied to the base of Q6022 through D6025 causing it to conduct. Thus lowering the potential at its collector. This lowered collector potential is applied to the base of Q6023 through R6073, causing Q6023 and Q6024 to conduct. The voltage at the collector of Q6024 increases. This increased potential is feed back to the base of Q6022 through R6078, D6028 and hold the Q6022, Q6023 and Q6024 conducting. The increased collector potential at Q6024 is applied to the base of Q6025 through R6074 causing it to conduct.

Thus lowering the potential at its collector.

This lowered collector potential at Q6025 is applied to the pin 5 of IC6002 through D6029. Thus, the Horizontal Oscillator is stopped and the high voltage is shut down.

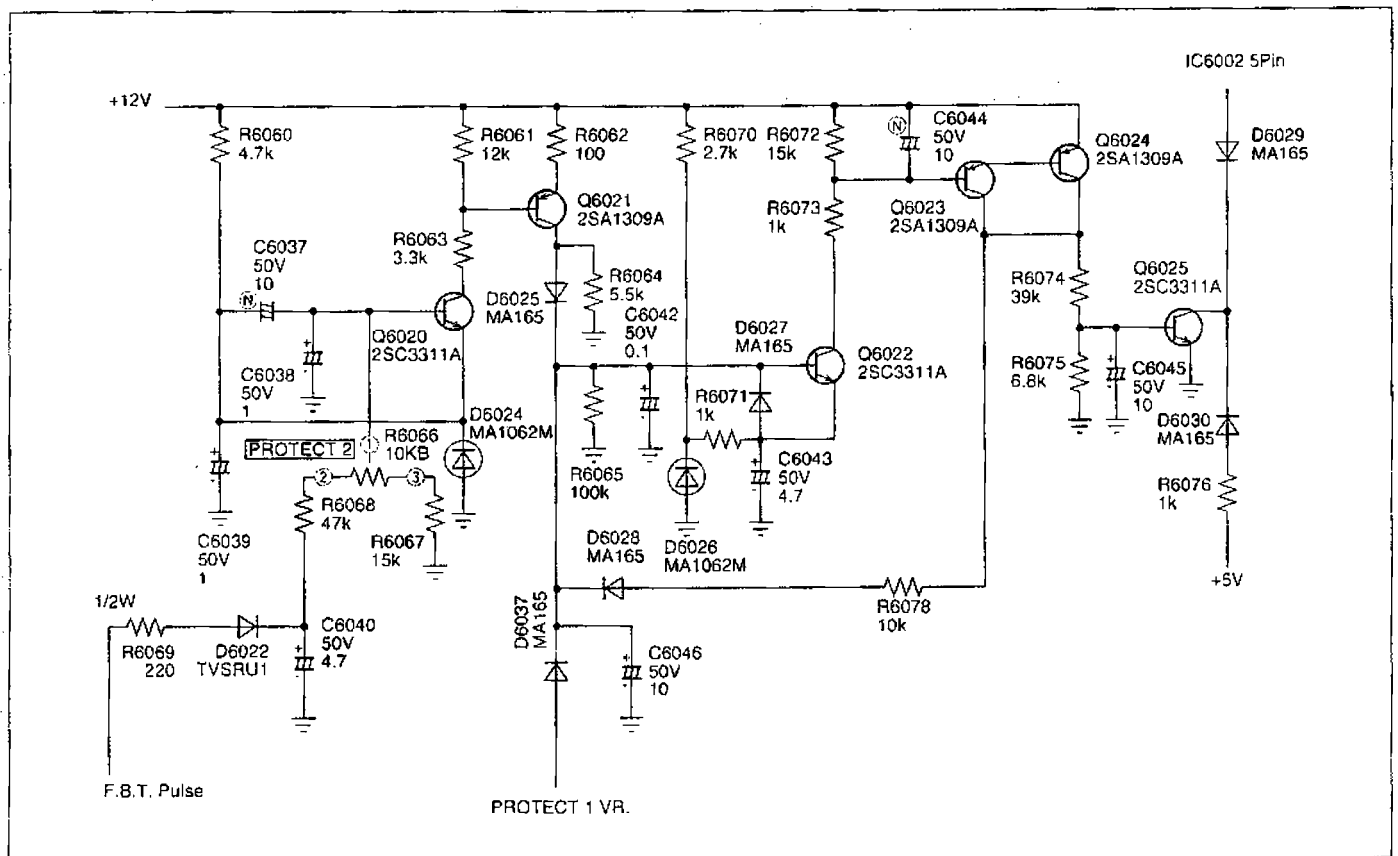

Fig. 6

2. Automatic High Voltage Regulator (See Fig. 8)

The CRT anode high potential is conducted through the breeder resistance contained to base of transistor Q6018 with low potential. The low impedance potential conducted by impedance transformer consist of the Darlington combination Q6017 and Q6018 and divider resistances consist of R6044, R6045 and R6046, from high impedance potential, is applied to the 5 pin of the operational amplifier (IC6001).

The operation amplifier (IC6001) compares the potential on the 5 pin (IC6001) with the reference potential on the 6 pin (IC6001) highly regulated by R6052 and sends, via Q6010 and Q6011, an error signal to the base of Q6012 and Q6013. Thus throttles the resistance of Q6012 and Q6013 to value that brings the system into balance.

High Voltage Potential	Potential Base of Q6018	Potential Base of Q6010	Potential Base of Q6012	High Voltage Potential
↑	↑	↑	↓	↓

Fig. 7

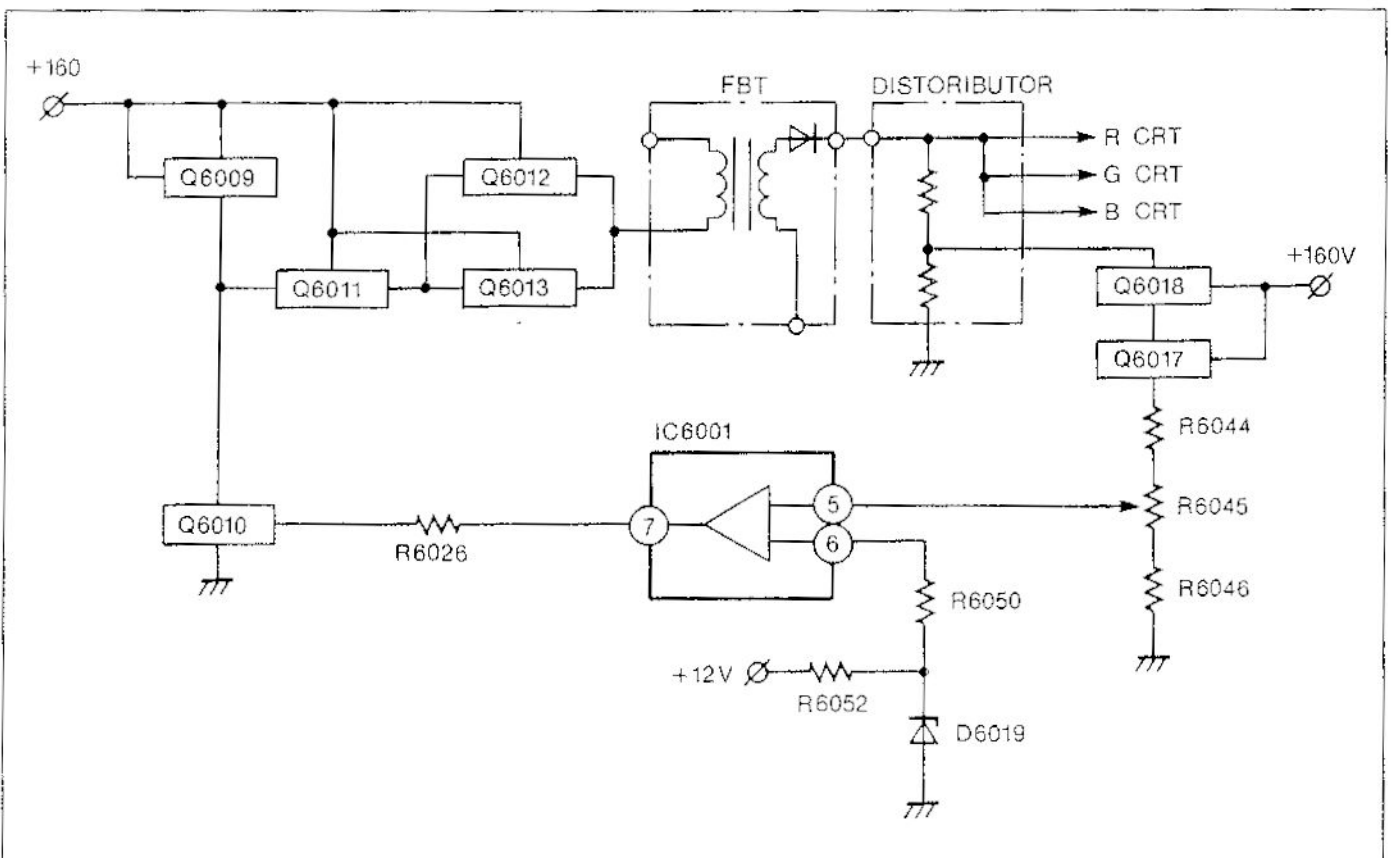
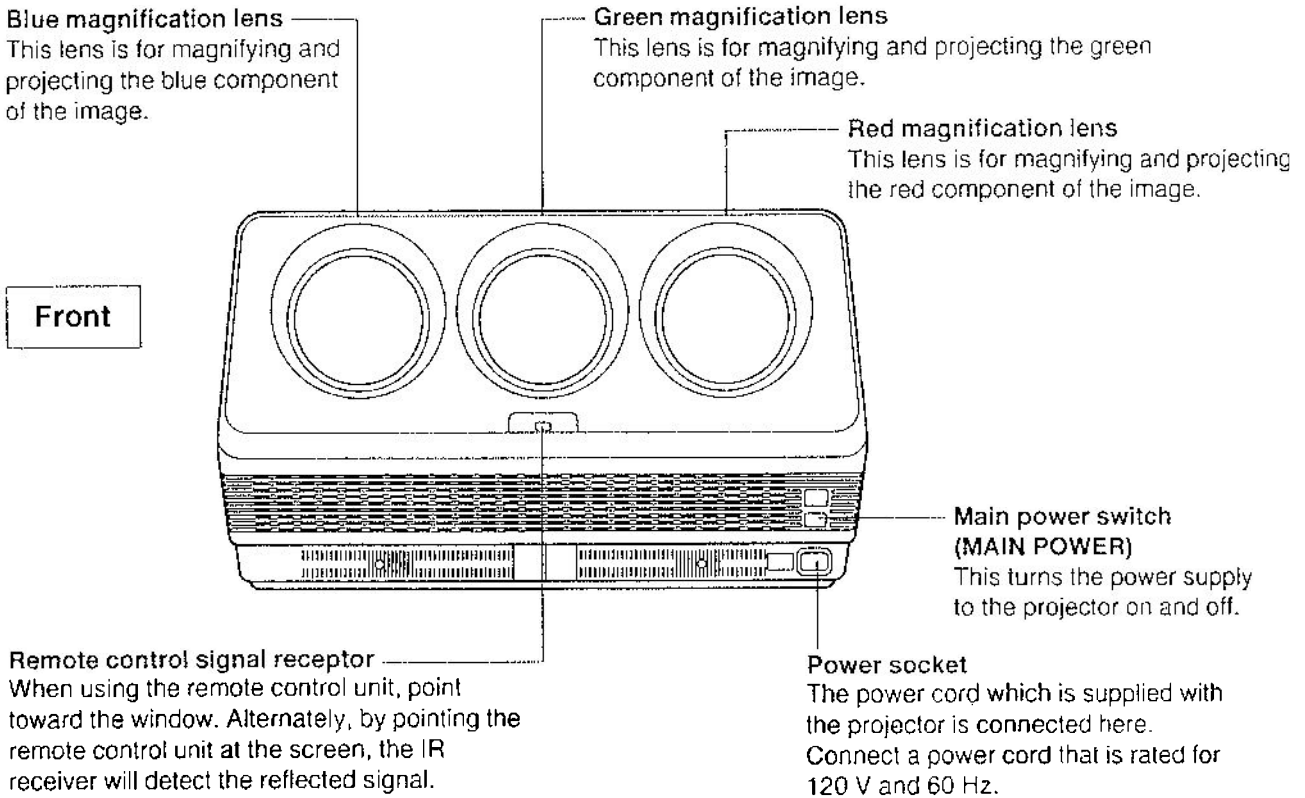

Fig. 8

Location of each projector part



Using the main control panel

Push the placed marked "PUSH", and then open the operation panel cover.

Projecting direction

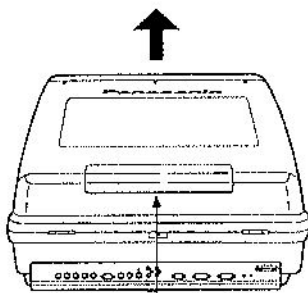

"PUSH" mark

If the power is turned on when the operation panel cover is opened, the operation panel light will illuminate. This makes it easy to see the operation panel when using the projector in dark places.

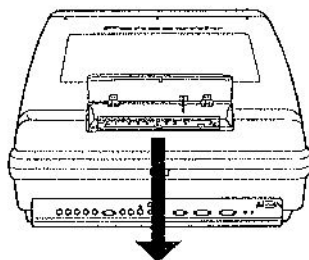

NOTE:

The panel cover can only be opened to an angle of 120°. If you try to open it further than that, the panel cover may be broken.

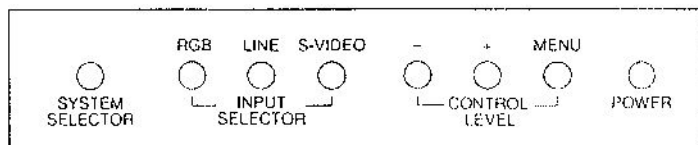

The projector user controls can always be adjusted by using the buttons on the operation panel, even if you don't have the remote control unit with you.

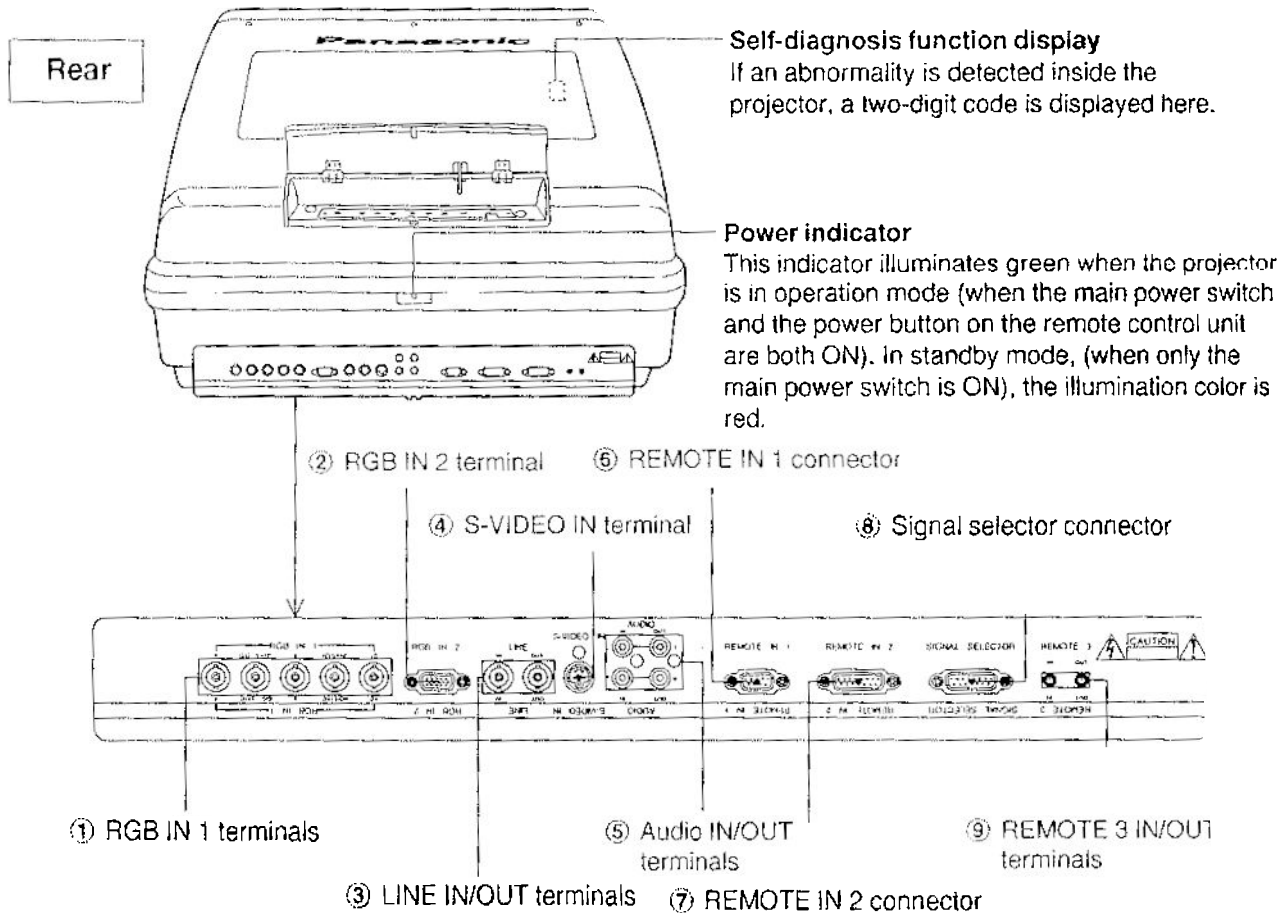

- ① **RGB IN 1 terminals (BNC × 5)**
These terminals are used to input analog RGB signals.
- ② **RGB IN 2 terminal (D-SUB HD15-pin × 1)**
This terminal can be used to input signals directly from a VGA-compatible personal computer, without the need for a video signal interface.
- ③ **LINE IN/OUT terminals (BNC × 2)**
These terminals are used to input and output video signals.
- ④ **S-VIDEO IN terminal (Mini DIN 4-pin)**
This terminal is used to input the Y and C separation signals.
- ⑤ **Audio IN/OUT terminals (RCA × 4)**
These terminals are used to input and output sound in stereo.
The projector remote control unit cannot be used to switch the audio source. Furthermore, the projector is not equipped with built-in speakers.
- ⑥ **REMOTE IN 1 connector (D-SUB 9-pin × 1)**
This connector is used when connecting an external control circuit.
- ⑦ **REMOTE IN 2 connector (D-SUB 15-pin × 1)**
This connector is used when connecting a personal computer in order to make adjustments to the projector during setup. It should only be used by a qualified technician.
- ⑧ **Signal selector connector**
This connector is reserved for use with a signal selector which is to be developed in the future. It cannot be used at the present.
- ⑨ **REMOTE 3 IN/OUT terminals (M3 plug)**
These terminals are used to connect the remote control unit to the projector using the accessory remote control cable.

Location of each remote control unit part

Buttons that can be used in normal operation mode

STD (Standard) button

This button is used to reset all of the projector adjustment values (BRIGHT, CONTRAST, TINT, COLOR, SHARPNESS) to the standard setting values.

ESC (Escape) button

This button is used to clear the screen of any characters that are being displayed.

STATUS button

This button is used to display the timing of signals which are being input and to list data that has been recorded.

POWER button

This button is used to turn the power supply for the projector on or to the standby mode.

Input selector buttons

These buttons are used to select the source for input signals received by the projector. It is not possible to switch over the audio signal source.

Numeric buttons

These buttons are used to input the ID number for the remote control.

Control pattern switch

This switch is used to change the functions of some of the remote control keys. It is only for use by a qualified technician, and should always be left at the NORMAL position during ordinary use.

ASPECT button

This switch is used to switch the projector to one of three modes. It is used when setting functions such as the aspect ratio.

ON SCREEN button

This button is used to turn the on-screen display of characters on and off.

SYSTEM SELECTOR button

This button is used to switch in coming video signal between VIDEO and S-VIDEO.

PNR (Picture noise reduction) button

This button is used to turn the picture noise reduction function on and off.

Picture adjustment buttons

These buttons are used to switch the projector to one of the picture adjustment modes (BRIGHT, CONTRAST, COLOR, TINT, SHARPNESS).

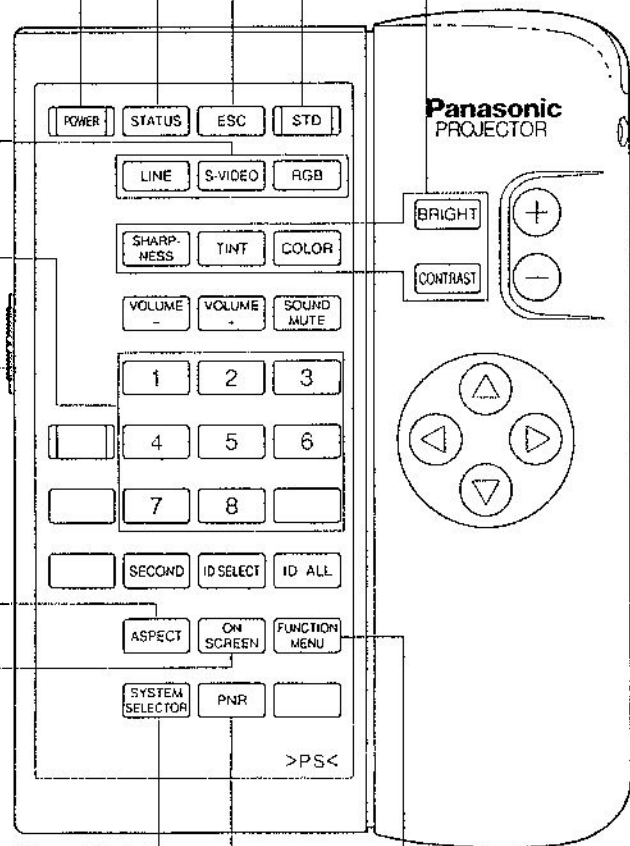

FUNCTION MENU button

This button is used to set the ID number, raster swing, baud rate and V-shift.

VOLUME + and VOLUME - buttons

These buttons are used to control the output level of the signal from the AUDIO OUT terminals.

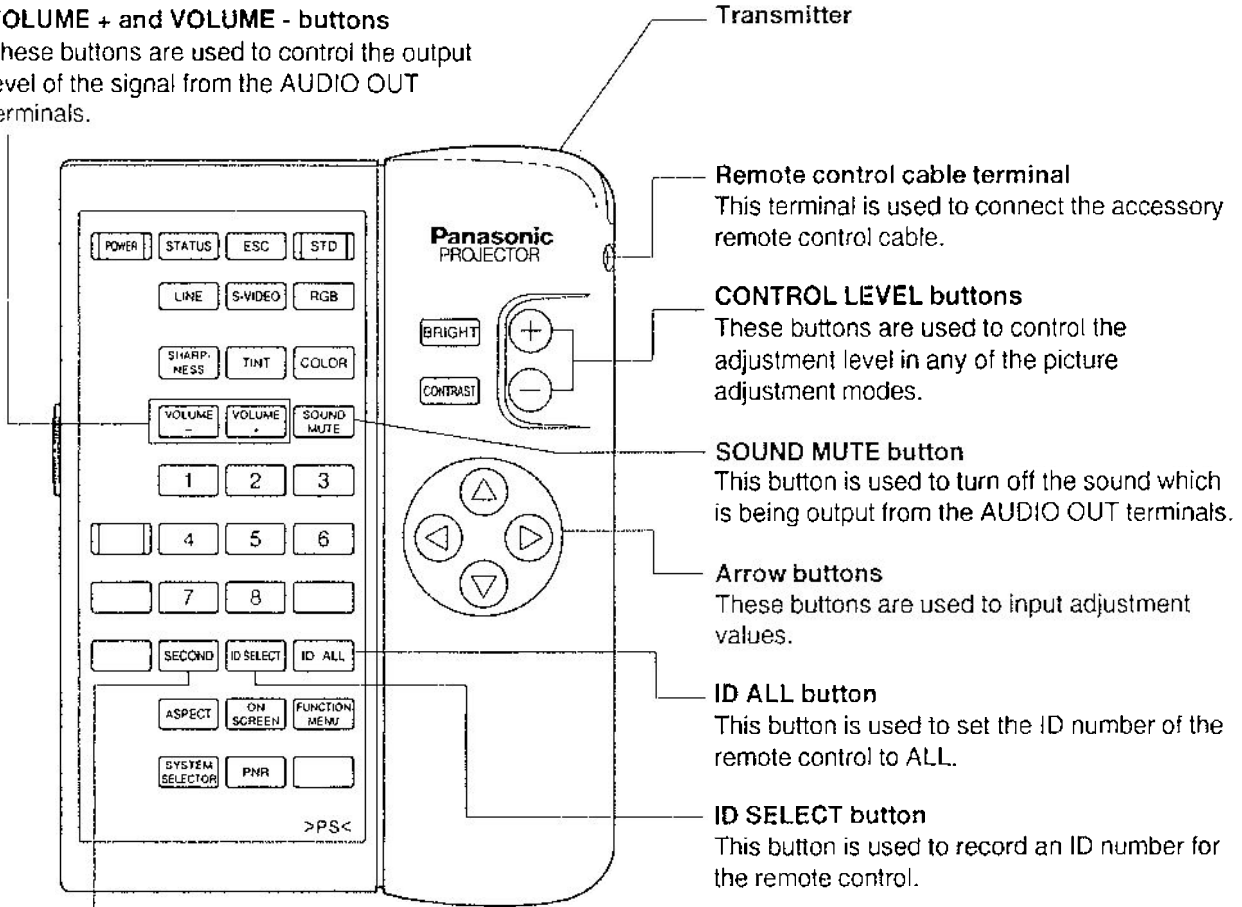

Transmitter

Remote control cable terminal

This terminal is used to connect the accessory remote control cable.

CONTROL LEVEL buttons

These buttons are used to control the adjustment level in any of the picture adjustment modes.

SOUND MUTE button

This button is used to turn off the sound which is being output from the AUDIO OUT terminals.

Arrow buttons

These buttons are used to input adjustment values.

ID ALL button

This button is used to set the ID number of the remote control to ALL.

ID SELECT button

This button is used to record an ID number for the remote control.

SECOND button

This button is reserved for operation of a signal selector which is to be developed in the future. The function of this key changes when the remote control unit is being used by a qualified technician to record signals.

Rear of remote control unit

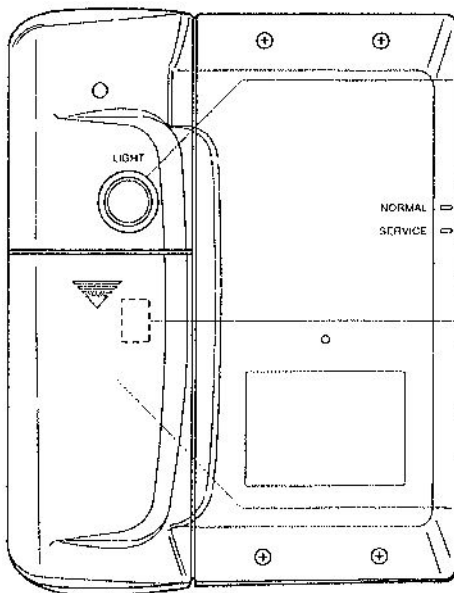

Light button

The buttons on the front of the remote control unit will be illuminated while this button is pressed. The button illumination will switch off approximately ten seconds after this button is released.

Function selection switch

The setting for this switch determines whether the operation mode is changed or not when the service mode switch is operated. It should be left at the OFF position during daily use so that service mode is disabled.

Battery compartment cover

Buttons that can be used in service mode

STD (Standard) button

This button is used to reset all of the projector adjustment settings to the factory default settings.

ESC (Escape) button

This button is used to cancel the operation of the STORE and STD buttons, and also to cancel adjustment modes and return to the normal screen.

STATUS button

This button is used to display the contents of signals which are being input and to list data that has been recorded.

POWER button

This button is used to turn the power supply for the projector on or to the stand-by mode.

Input selector buttons

These buttons are used to select the source for input signals received by the projector.

RASTER SIZE button

This button is used to adjust the height and width of the picture on the screen.

Control pattern switch

This switch is used to switch the remote control operation mode between normal operation mode and service mode. (If you want to switch to service mode, set the service mode switch inside the battery compartment to "ON".)

RGB POSITION button

This button is used to adjust the position of the center of the picture.

STORE button

This button is used to register data such as convergence adjustment data.

Convergence mode buttons

These buttons are used to carry out adjustments in dynamic convergence mode.

ASPECT button

Three modes can be registered for each different type of signal.

White balance adjustment mode buttons

These buttons are used to switch to white balance adjustment mode.

RGB buttons

These buttons are used to select the color for adjustment in convergence adjustment mode and other modes.

RASTER LIN button

This button is used to switch to vertical and horizontal linearity adjustment mode.

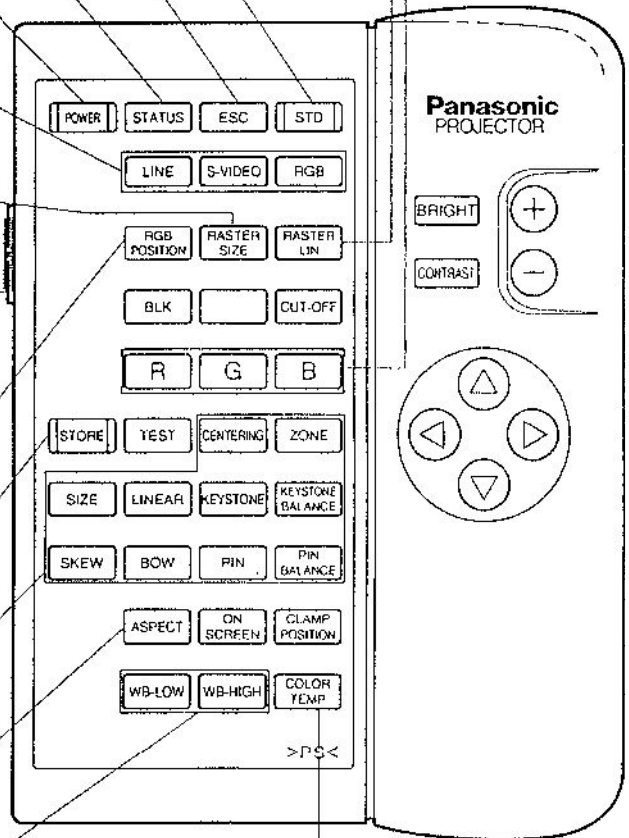

COLOR TEMP button

This button is used to switch the color temperature setting between LOW, MID and HIGH.

BLK button

This button is used to crop unnecessary parts from the upper, lower, left and right edges of pictures on the screen.

CUT-OFF button

This button is used to turn off individual projection tubes.

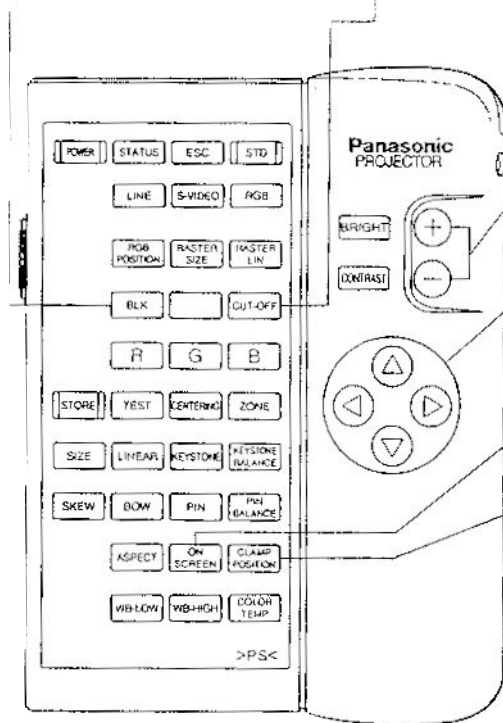

CONTROL LEVEL buttons

These buttons are used to select adjustment modes, to change setting levels and to move the cursor around the screen.

Arrow buttons

These buttons are used to change setting levels and to move the cursor around the screen.

ON SCREEN button

This button is used to turn the on-screen display of characters on and off.

CLAMP POSITION button

This button is used to change the clamp position for the black level of the video signal.

TEST button

Rear of remote control unit

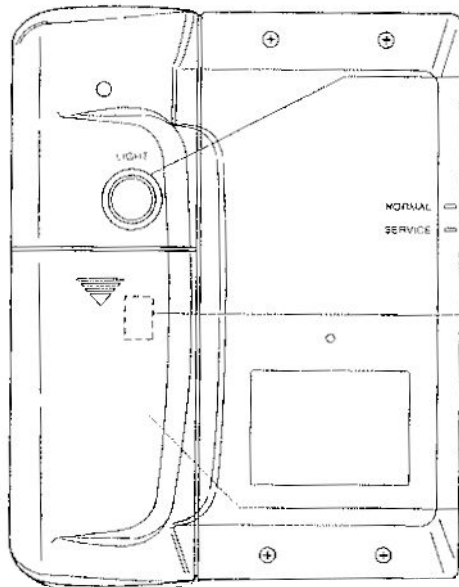

Light button

The buttons on the front of the remote control unit will be illuminated while this button is pressed. The button illumination will switch off approximately ten seconds after this button is released.

Function selection switch

The setting for this switch determines whether the operation mode is changed or not when the service mode switch is operated.

Battery compartment cover

System configuration examples

Notes on setting up a system

- Turn off the power supply for each input device before connection.
- Read the instruction manual for each input device before connection.
- If the cables which are necessary for connecting any of the input devices to the system are not provided with the devices, contact your dealer.
- The projector is not provided with its own speakers, so you will need to connect an external amplifier and speakers in order to obtain audible sound output.
- The following types and ranges of signals can be input to the projector.

Analog RGB signals

Horizontal scanning frequency: 15 ~ 100 kHz (PT-M1085U)

15 ~ 70 kHz (PT-M1083U)

Vertical scanning frequency: 38 ~ 150 Hz

Composite video and S-VIDEO signals

NTSC, M-NTSC, PAL, SECAM

A separate interface will be required if the input signal levels are not appropriate.

- If there is a lot of jitter in the video signal input from the video source, the picture on the screen may flicker or be unstable. In such cases, it will be necessary to connect a TBC (time base corrector).
- If the synchronizing signal is a composite sync signal, connect the signal source to the "H/H.V" terminal; if it is a separate sync signal, connect to the "H/H.V" and "V" terminals.
- Do not use the "H/H.V" or "V" signals if the input is a SYNC ON G signal.

Example of a system connected to the RGB IN 1 terminals

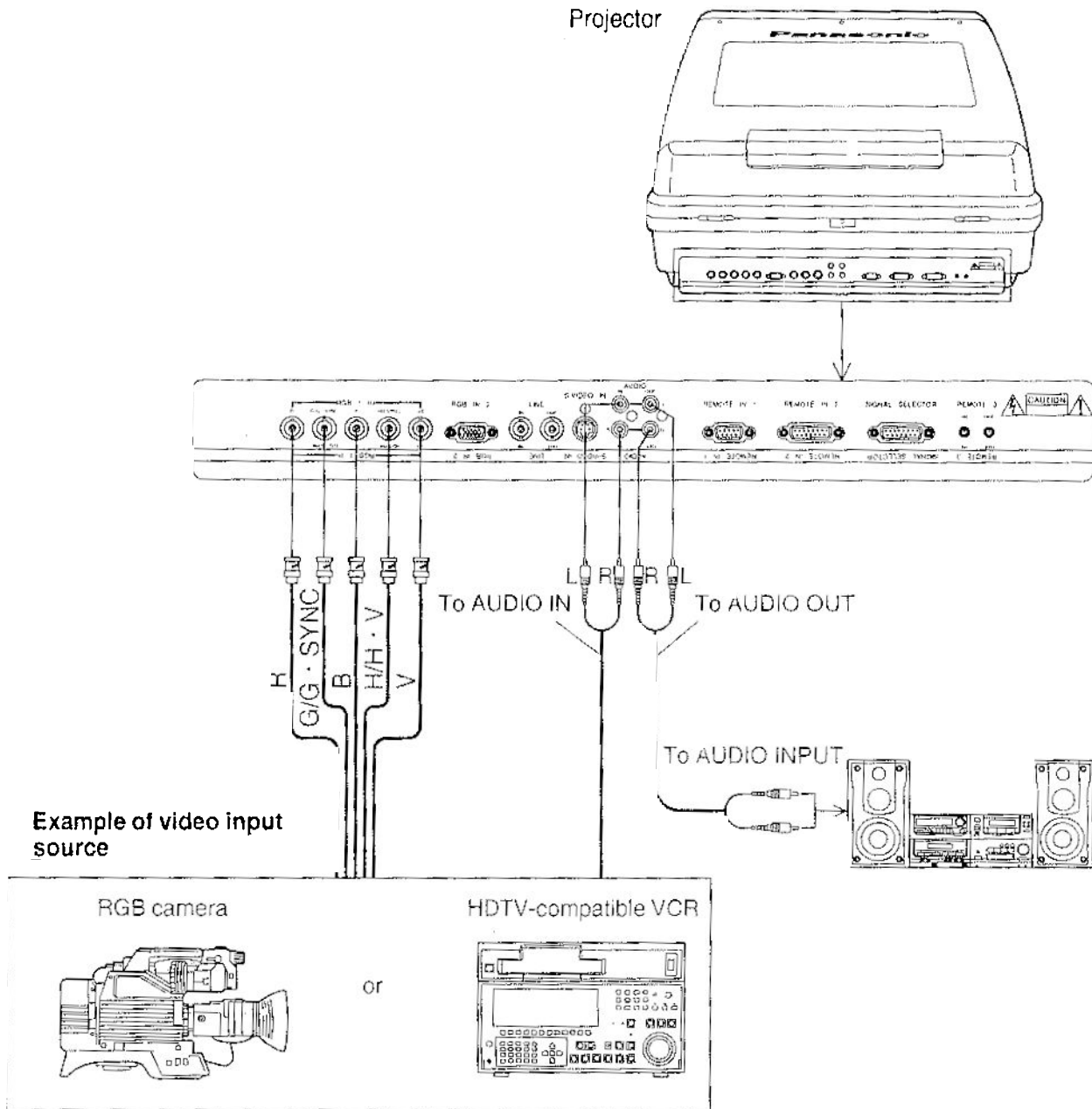

NOTE:

- The projector is not equipped with built-in speakers, so you will need to connect an external amplifier and speakers.
- The audio source for the projector cannot be changed.

Example of a system connected to the RGB IN 2 terminal

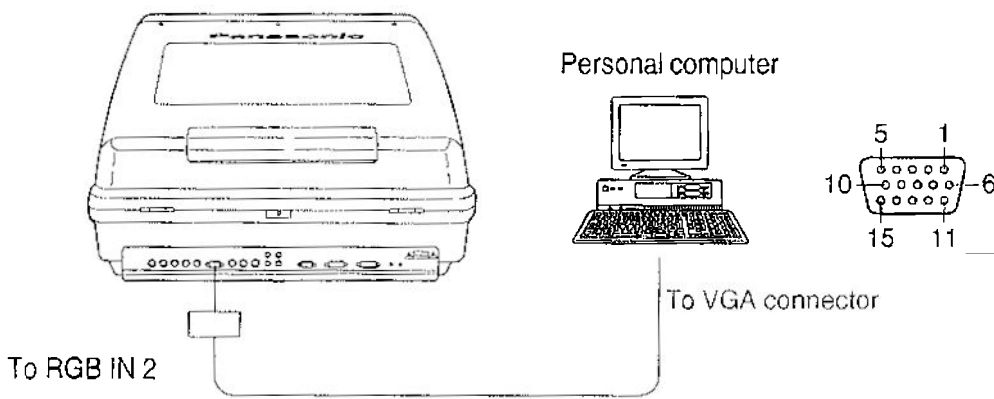

Pin No.	Signal name
1	Red
2	Green
3	Blue
4	GND
5	GND
6	Red GND
7	Green GND
8	Blue GND
9	GND
10	GND
11	GND
12	GND
13	H-Sync
14	V-Sync
15	GND

Example of a system connected to the LINE/S-VIDEO terminals

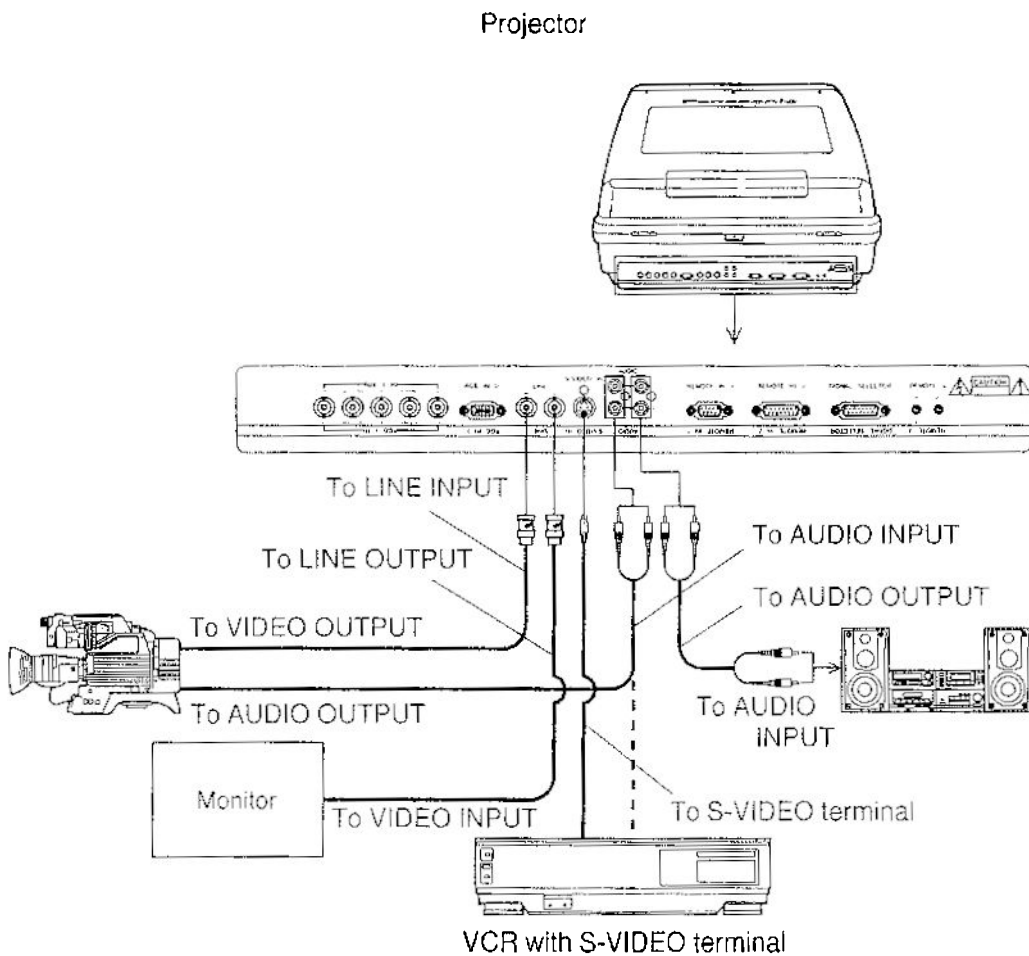

NOTE:

- The projector is not equipped with built-in speakers, so you will need to connect an external amplifier and speakers.
- The audio source for the projector cannot be changed.

Connecting to a S-VIDEO signal source

Projector terminal

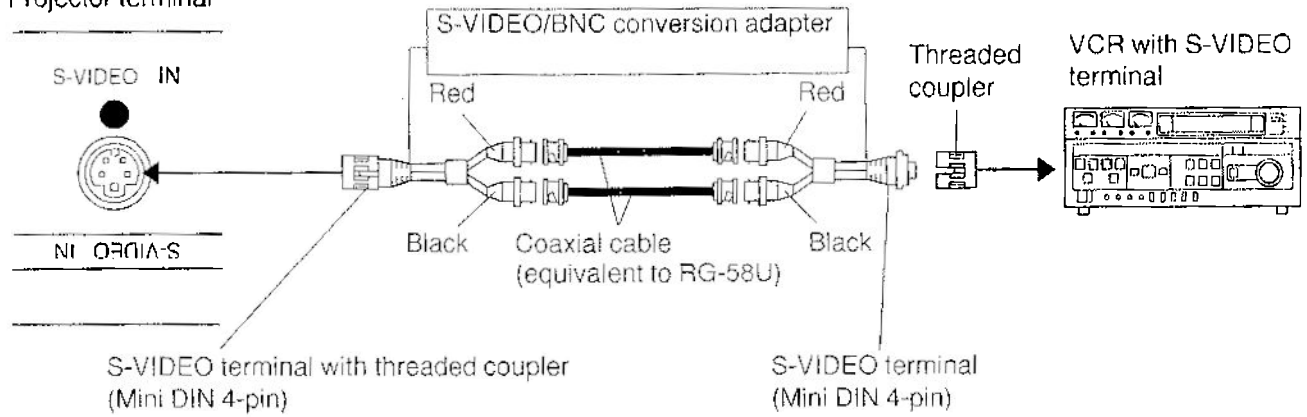

This is used to screw and lock onto the S-VIDEO terminal on the projector.

If the S-VIDEO output terminal on the VCR is a screw-type terminal, the adapter should be attached before connecting the cable to the terminal.

These conversion adapters make it possible to increase the distance between the S-VIDEO terminal connections using BNC cables.

Points to note:

1. The cables used should be of the same length, and this length should not exceed 328 feet (100 m). Exceeding this length will have an adverse effect on Y/C signal transmission.
2. The connectors are color keyed; the Y signal connector is red and the C signal connector is black.

Care should be exercised to ensure proper "red" to "red" and "black" to "black" cable connection.

3. To prevent connector damage or loss, do not place too much strain on the S-VIDEO connectors once they are connected.

Pin No.	Description	Pin No.	Description
1	GND	3	Y signal input
2	GND	4	C signal input

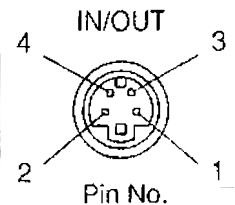

Connecting an advanced digital scanning converter (sold separately)

A separate advanced digital scanning converter (ET-100DS) can be used to convert the signals from the video source to RGB signals (with a horizontal scanning frequency of 31.5 kHz).

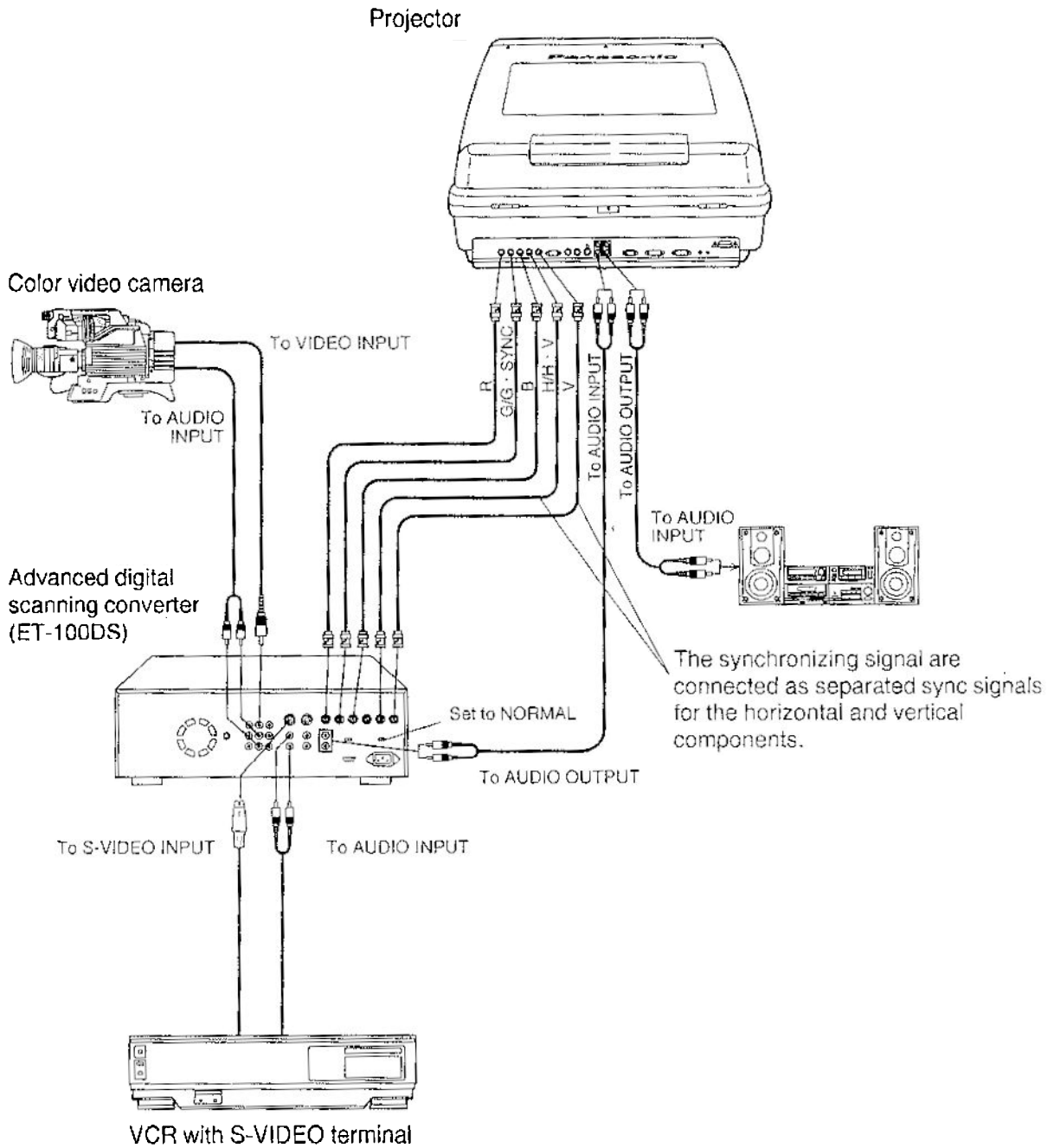

Disassembly Instructions

WARNING:

1. Before disassembly, remove the AC plug from the wall outlet.
2. When turning over a P.C. board to adjust it, be sure to lay on insulating material under it in order to prevent shorting.
3. P.C. boards and wires should not be pulled forcibly, but be handled carefully.
4. Printed boards and connectors should be handled with care-avoid handling them forcibly !
5. When handling the E, K and P-P.C. board with the power ON, there is a risk of an Electric shock if you use the COLD side heat sink while working on the HOT side of the chassis.

CIRCUIT BOARD LAYOUT

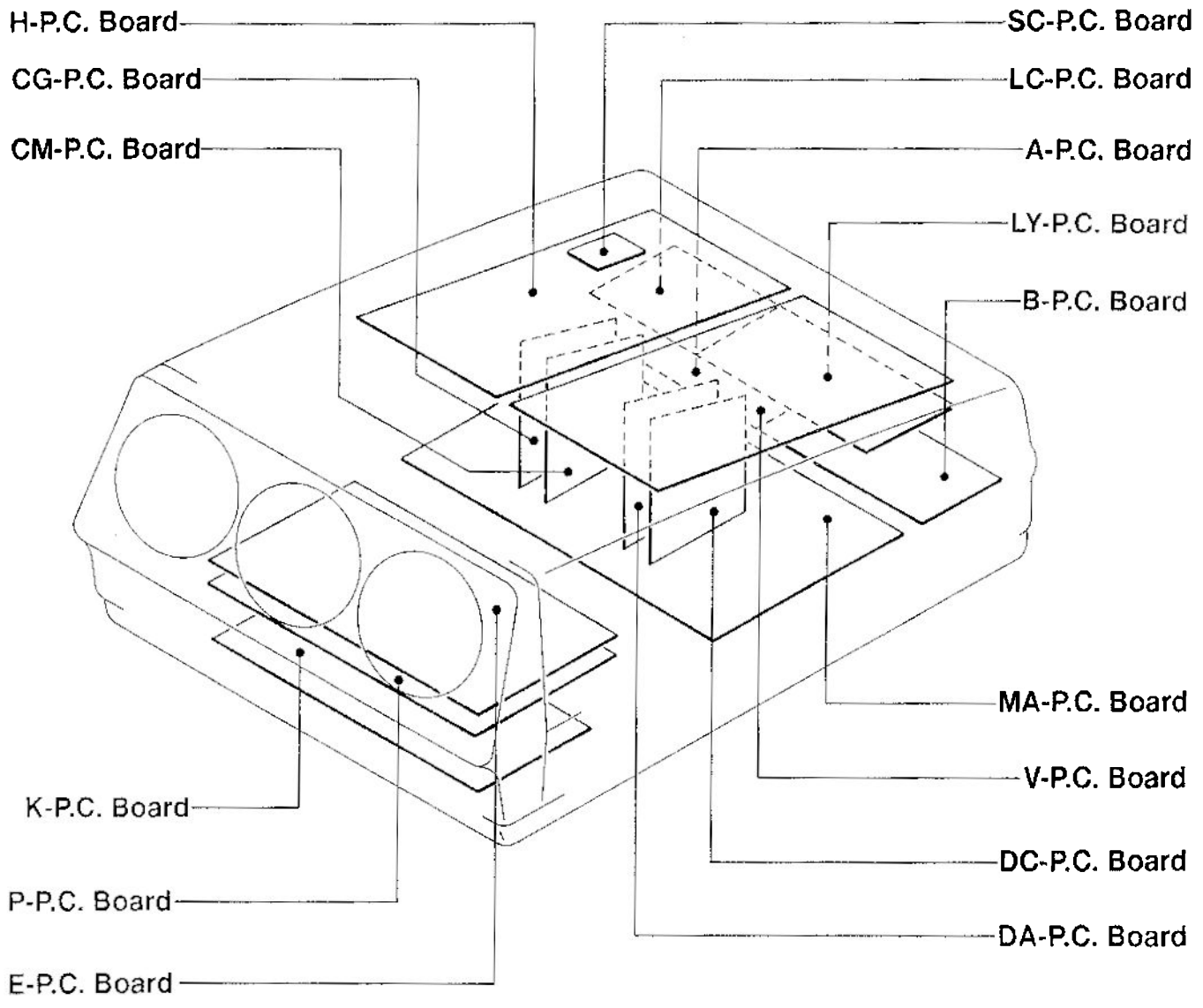

DISASSEMBLY FLOWCHART

This flowchart indicates disassembly items of the cabinet parts and circuit boards in order to find the items necessary for servicing. When reassembling, perform the steps in the reverse order.

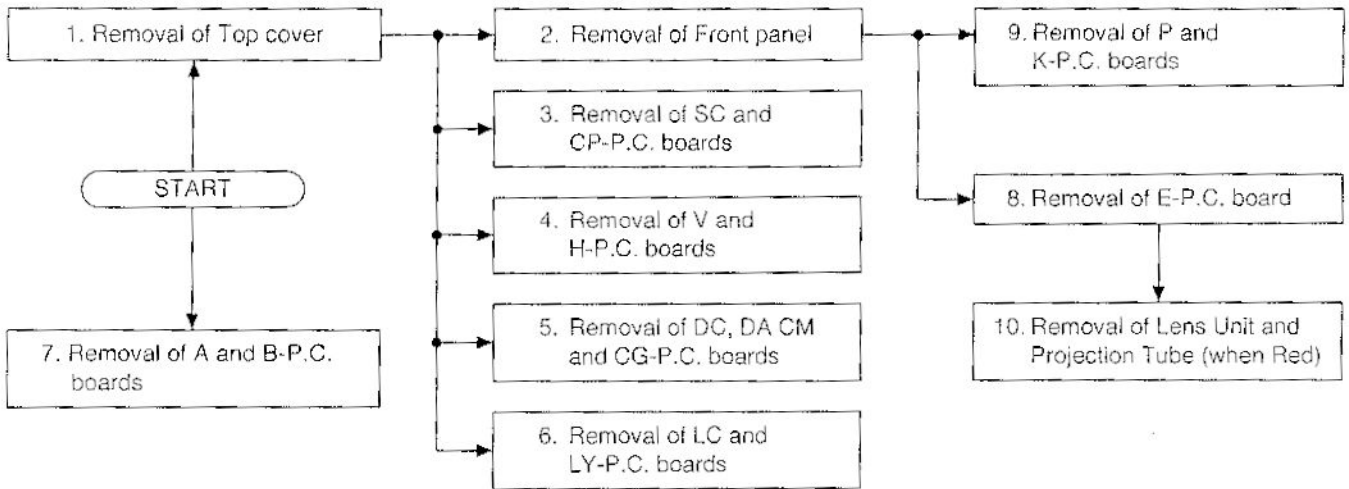

1. Removal of Top cover

1. Open the control panel cover, and remove 2 screws (A).
2. Remove 3 screws (B).
3. Pushing the lock button of the both side, and then open the top cover to direction of arrows.

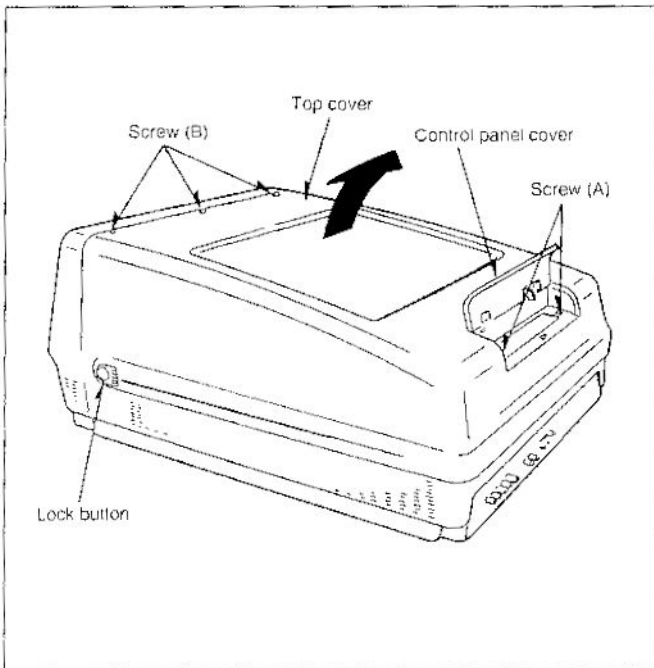

Fig. 1

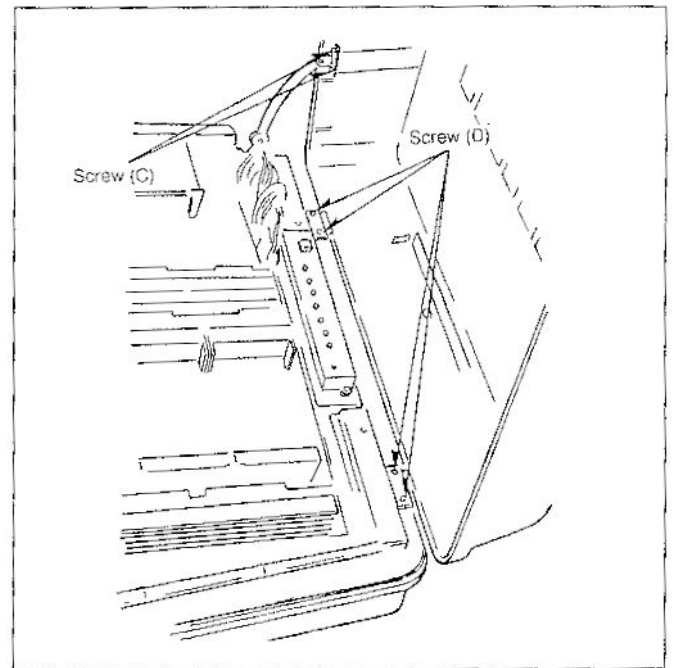

Fig. 2

Note: When the top cover interrupted with the servicing; Remove 2 screws (C) and 4 screws (D).

2. Removal of Front panel

1. Remove 6 screws (E).

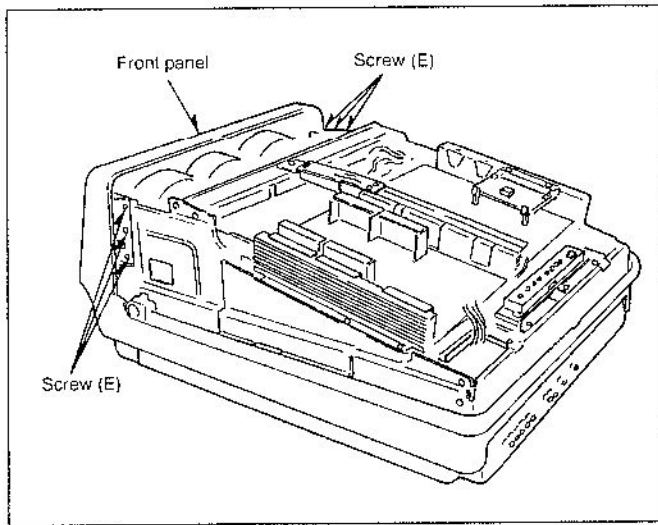

Fig. 3

2. Remove 2 screws (F).
3. Remove the Front panel.

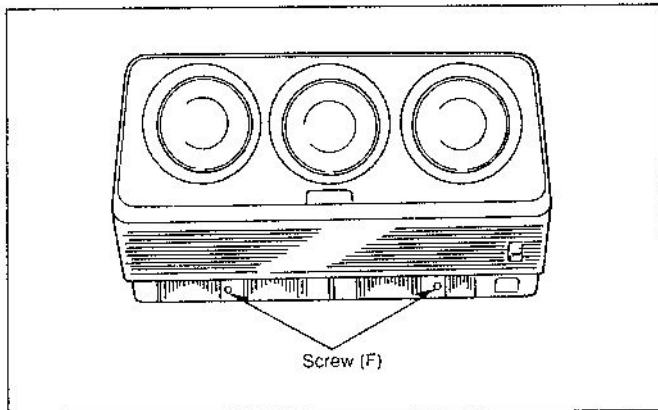

Fig. 4

3. Removal of SC-P.C. board and CP-P.C. board

1. Remove 2 screws (G).
2. Remove 2 hooks (H).
3. Remove the SC-P.C. board.
4. Remove 2 screws (I) and remove the CP-P.C. board.

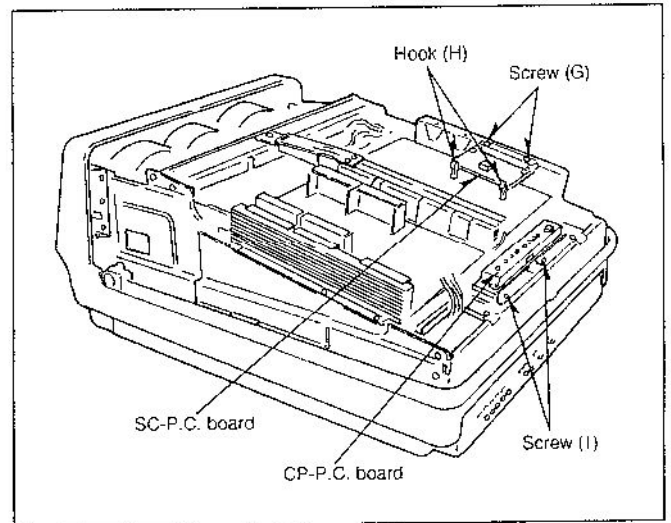

Fig. 5

4. Removal of V-P.C. board and H-P.C. board

1. Remove 3 screws (J), and removal a Fixing angle.
2. Remove 4 screws (K), then loosen 2 screws (L).
3. Lift the V-P.C. board and H-P.C. board toward the Front panel.

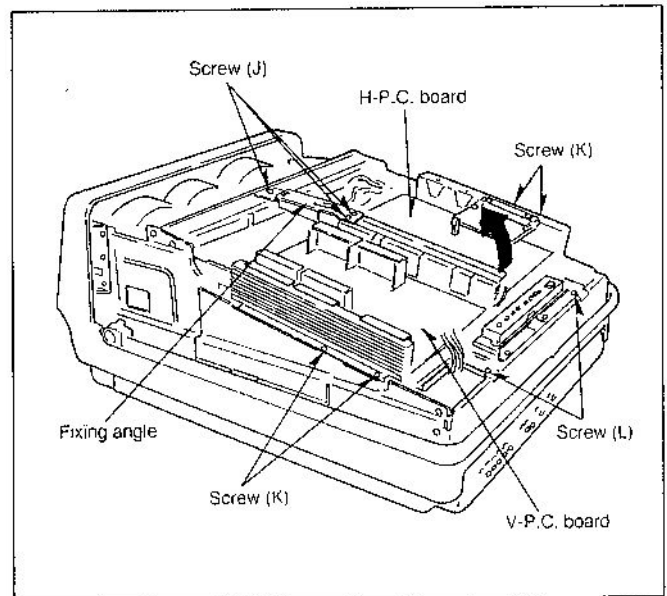

Fig. 6

4. Remove 2 screws (M) for the V-P.C. board and 2 screws (N) for the H-P.C. board.
5. Then close the V-P.C. board and H-P.C. board.
6. Remove 2 screw (O), and remove the Fan motor.

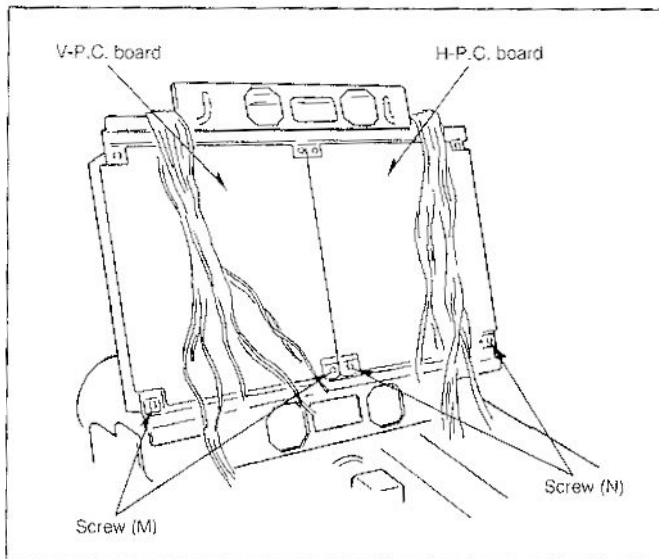

Fig. 7

● **Removal of V-P.C. board**

7. Remove 5 screws (P), then pull the V-P.C. board toward rear panel for removal.

● **Removal of H-P.C. board**

8. Remove 5 screws (Q), then pull the H-P.C. board toward rear panel for removal.

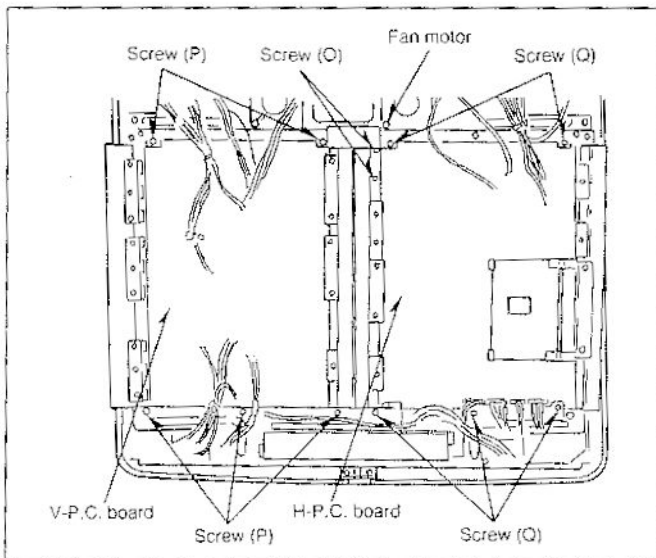

Fig. 8

5. Removal of DC, DA, CM and CG-P.C. boards

1. Open the V and H-P.C. boards.
2. Remove 4 screws (R).
3. Remove 2 board cover plates.

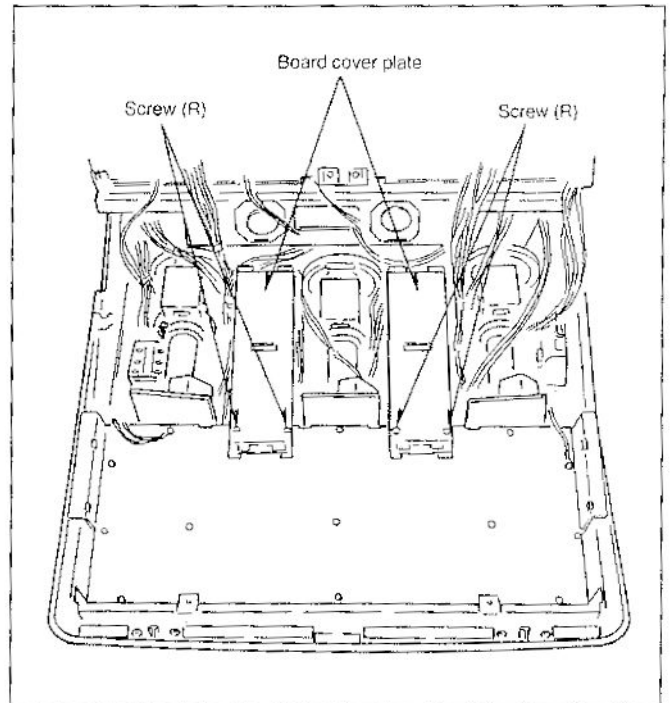

Fig. 9

4. Pull and lift the DC, DA, CM and CG-P.C. boards.

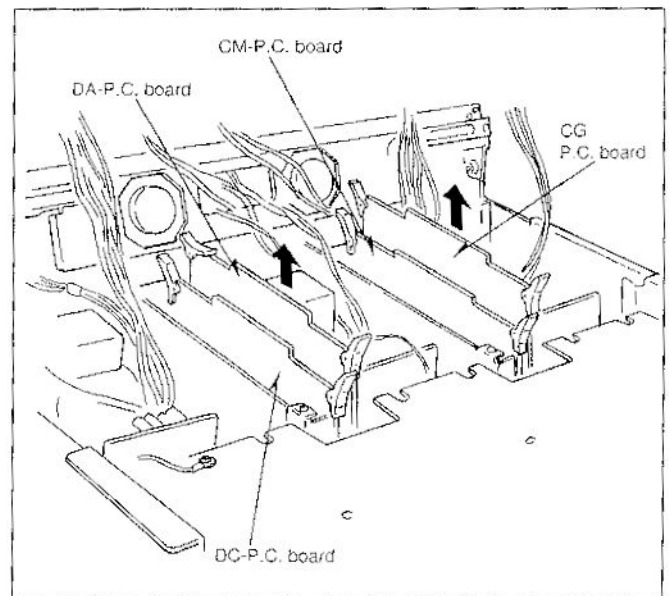

Fig. 10

Note:

When checking the DC-P.C. Board, connect 48 pin-extension board between DC-P.C. Board and MA-P.C. Board. For connecting method, see item 11.

6. Removal of LC and LY-P.C. board

1. Remove 13 screws (S), and remove the board cover plate.

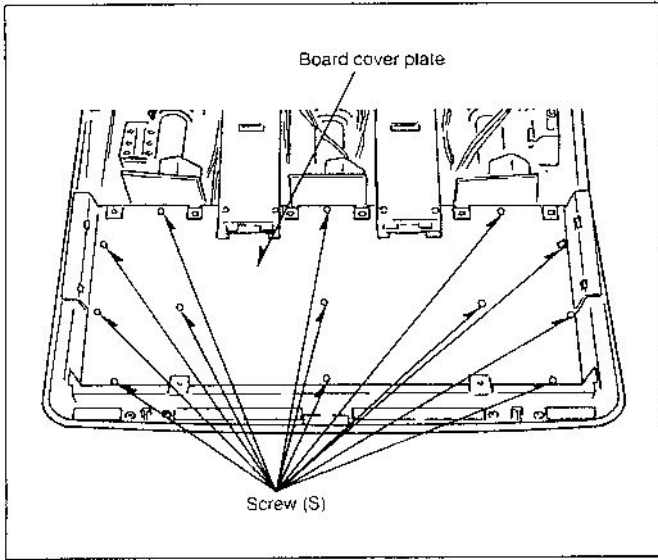

Fig. 11

2. Remove 4 screws (T), and remove the LC-P.C. board.
3. Remove 7 screws (U), then remove the LY-P.C. board.

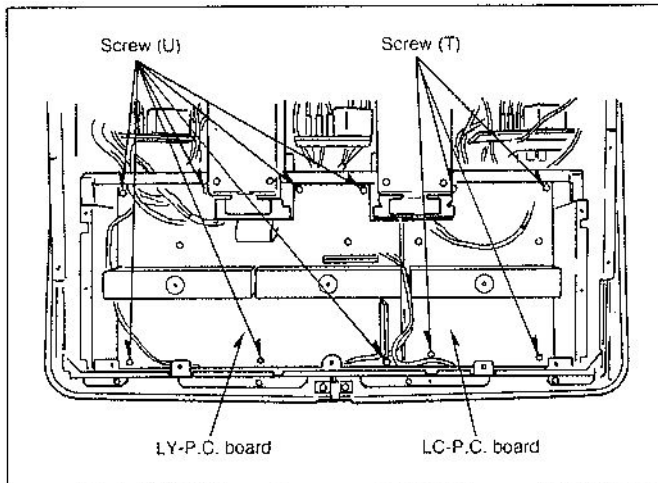

Fig. 12

7. Removal of A and B-P.C. board

1. Remove 9 screws (V) and remove the rear terminal panel.

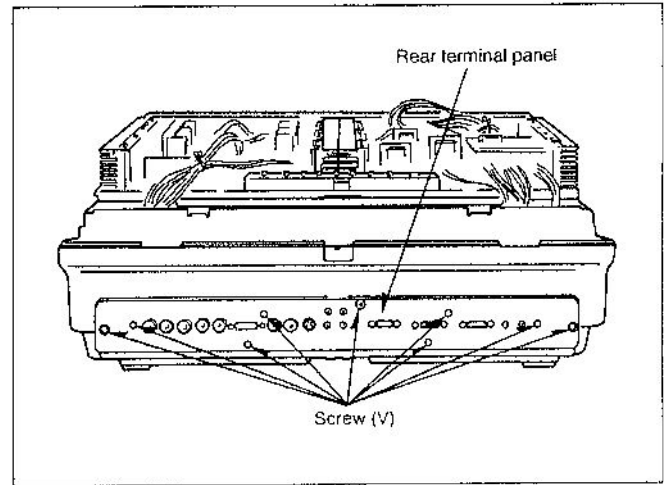

Fig. 13

2. Pull out the A and B-P.C. board toward you.

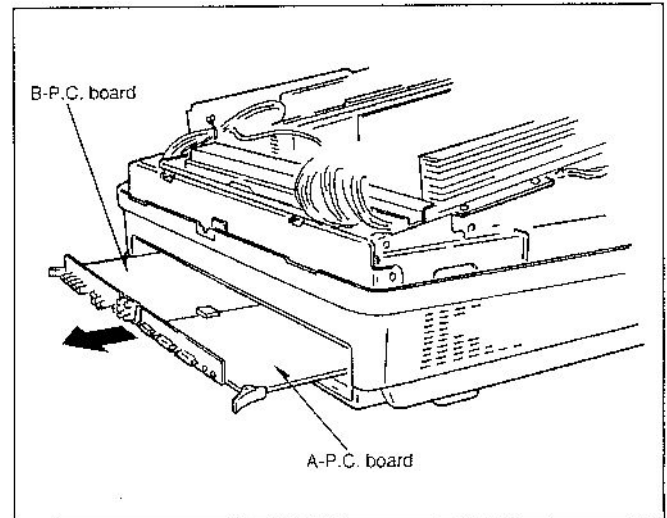

Fig. 14

Note:

When checking A and B-P.C. Boards, connect 48 pin-extension board (2 pcs.) and 96 pin-extension board between A and B- P.C. Boards and MB-P.C. Board. For connecting method, see item 11.

8. Removal of E-P.C. board

1. Removal 2 screws (W).
2. Pull out the E-P.C. board toward you.

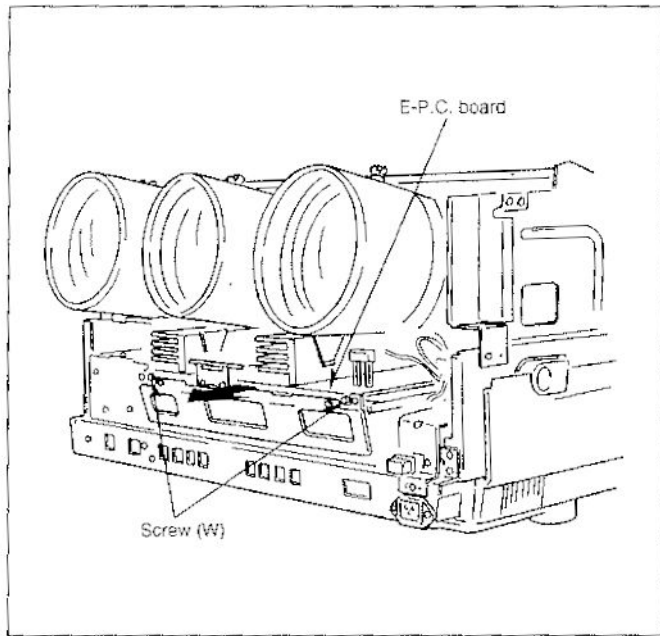

Fig. 15

9. Removal of P and K-P.C. board

1. Remove 8 screws (X).
2. Carefully slide the P and K-P.C. boards toward you.

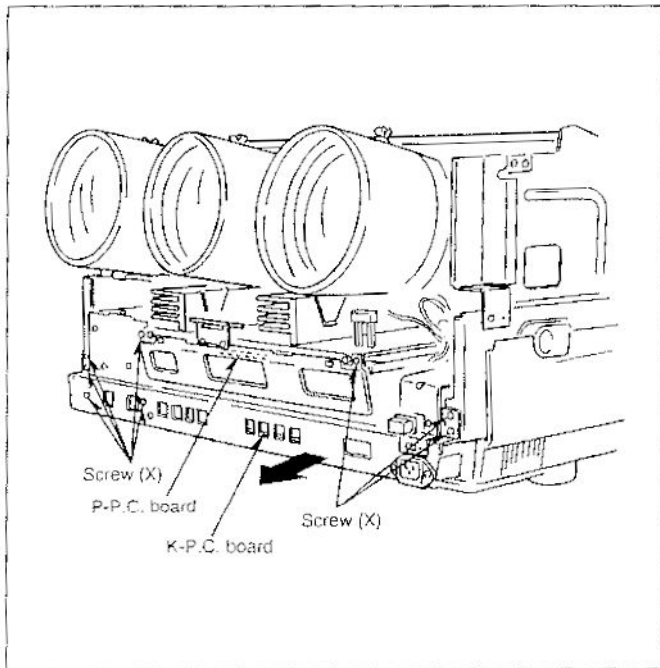

Fig. 16

3. Remove 4 screws (Y), and remove the P-P.C. board.

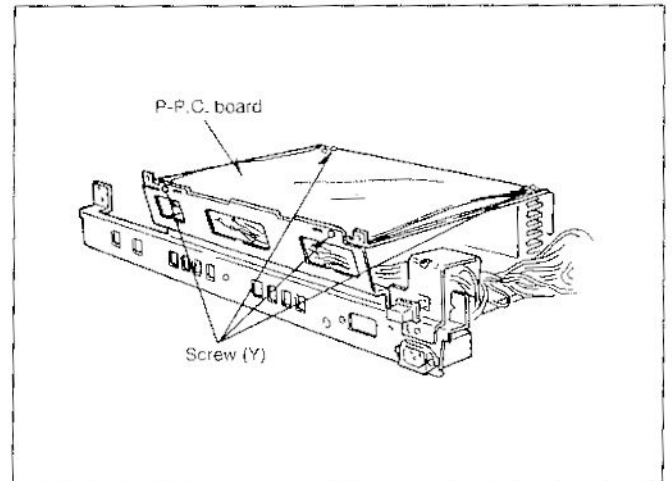

Fig. 17

4. Remove 4 screws (Z), and remove the slide case plate.

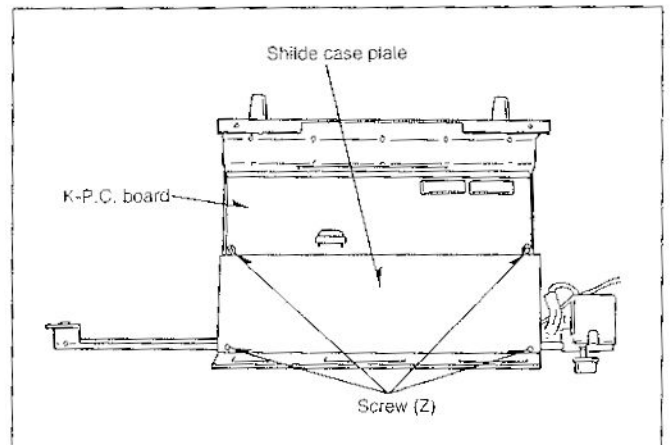

Fig. 18

5. Remove 6 screws (a), and remove the K-P.C. board.

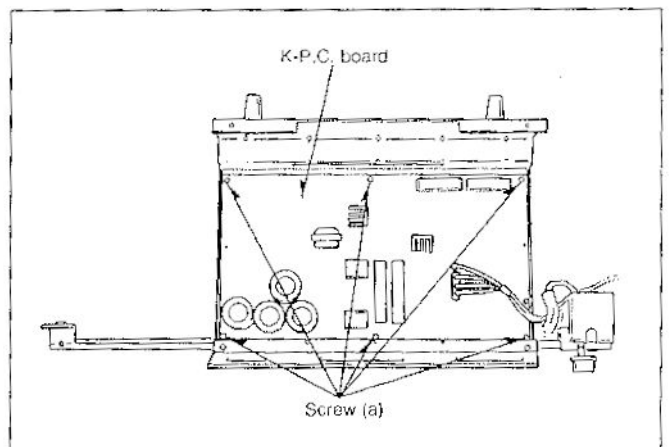

Fig. 19

10. Removal of Lens Unit and Projection Tube (when Red)

- 1. Remove the Top cover and Front panel.
(Refer to item 1, 2.)
- 2. Lift the V and H-P.C. board. (Refer to item 4.)
- 3. Remove the anode lead from the distributor.
- 4. Remove the LR-P.C. board, and draw out deflection yoke (with focus magnet and alignment magnet) by loosening a screw (b).

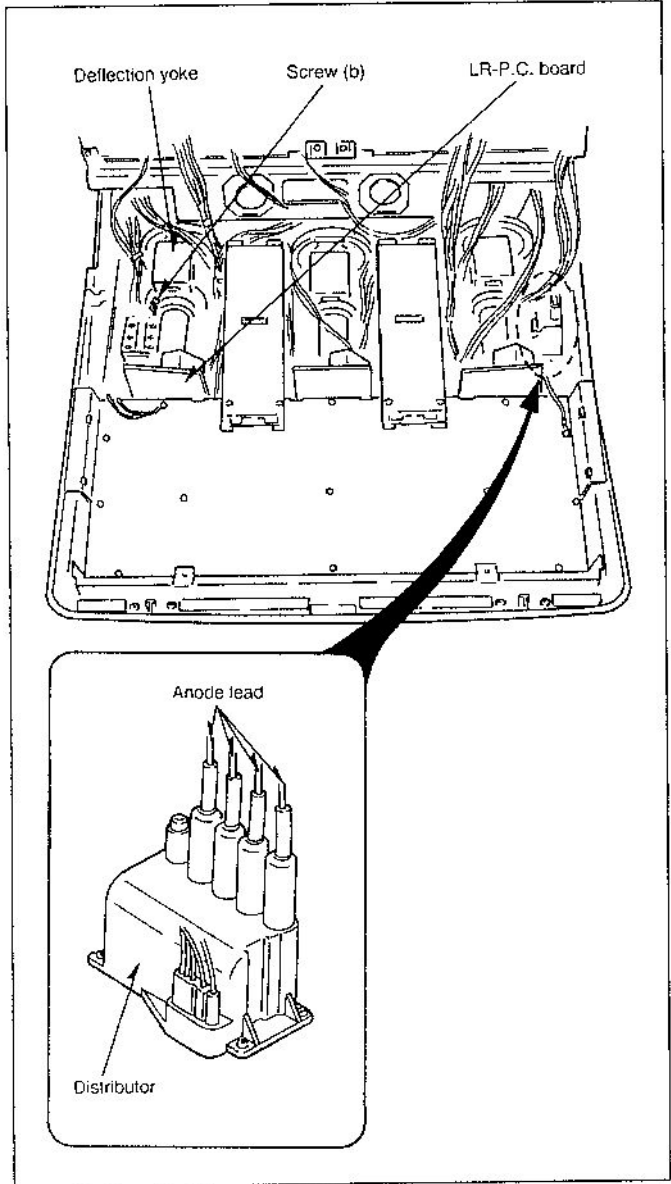

Fig. 20

- 5. Remove the E-P.C. board. (Refer to item 8.)
- 6. Remove 4 screws (d), and carefully pull out the Lens Unit toward you.

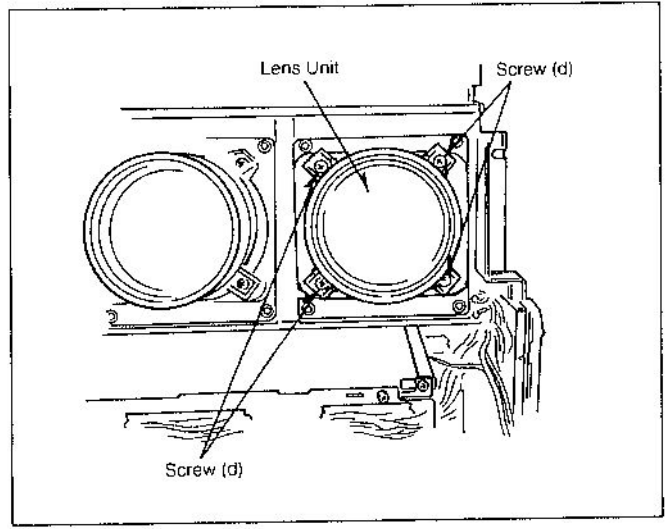

Fig. 21

- 7. Remove 4 screws (e), and carefully pull out the Projection Tube toward you.

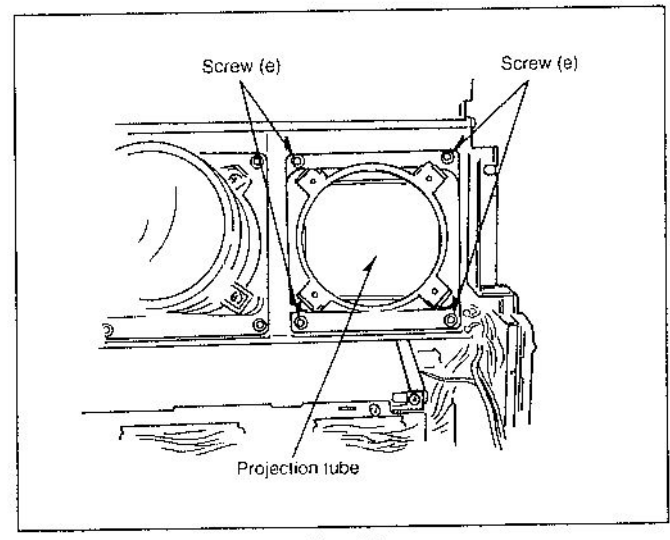

Fig. 22

11. How to connect the extension boards to DC, A and B-P.C. Boards.

When checking each P.C. Board, use the extension board. The extension boards required are as follows.

P.C. Board	Extension Board	Part No.	Q'ty
DC	96 pin	TZS507036	1 pc.
A	96 pin	TZS507036	1 pc.
B	48 pin	TZS507035	2 pcs.

2. Fig. 23 shows the connection of each extension board with each P.C. Board.

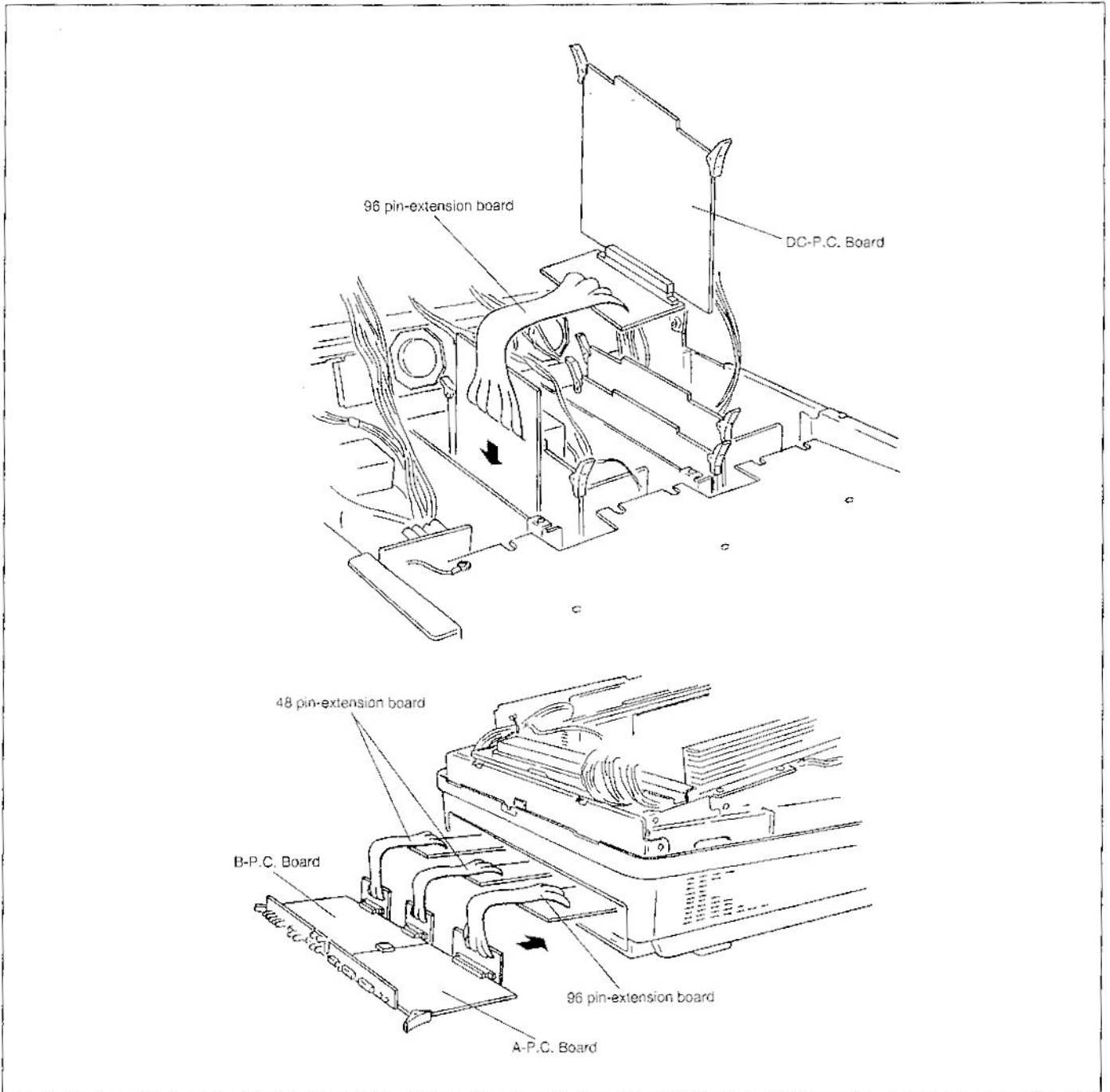
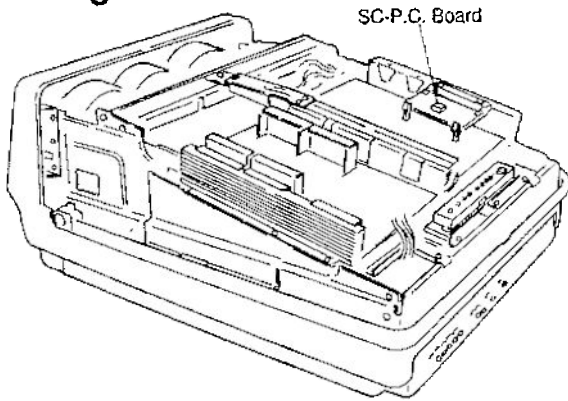

Fig. 23

Self-Diagnosis Function



This Video System Projector has the SC-P.C. Board built-in (self-diagnosis circuit), which indicates the abnormal area with double-digit code, if any malfunction should happen.

Check the relevant P.C. Board in conformity with the following chart when any malfunction happened.

Indications appear when the main power switch is ON (at the time of standby).

NOTE.

Basic self-diagnosis functions of this Video System Projector are detection and indication of malfunctions, including (1) High Voltage (2) Power Supply (P1, P2, P3), (3) Horizontal Deflection, (4) Vertical Deflection, (5) Fan Motor and (6) EEPROM.

Check the relevant P.C. Board.

Self-Diagnosis Indication Chart

CODE No.	HIGH VOLTAGE	POWER SUPPLY STOP			H- DEFLEC.	V- DEFLEC.	FAN MOTOR	EEPROM
		P1	P2	P3				
01	—	—	—	—	○	—	—	—
02	—	—	—	—	○	—	—	—
03	—	—	—	—	○	—	—	—
04	—	—	—	—	○	—	○	—
08	—	—	—	—	○	—	—	—
09	—	—	—	—	○	—	—	—
0A	—	—	—	—	○	—	—	—
0B	—	—	—	—	○	—	—	—
10	—	—	—	—	○	—	—	—
11	○	—	—	—	○	—	—	—
12	○	—	—	—	○	—	—	—
13	○	—	—	—	○	—	—	—
18	○	—	—	—	○	—	—	—
19	○	—	—	—	○	—	—	—
1A	○	—	—	—	○	—	—	—
1B	○	—	—	—	○	—	—	—
20	○	○	—	—	○	—	—	—
21	○	○	—	—	○	—	—	—
22	○	○	—	—	○	—	—	—
23	○	○	—	—	○	—	—	—
28	○	○	—	—	○	—	—	—
29	○	○	—	—	○	—	—	—
2A	○	○	—	—	○	—	—	—
2B	○	○	—	—	○	—	—	—
30	○	○	—	—	○	—	—	—
31	○	○	—	—	○	—	—	—
32	○	○	—	—	○	—	—	—
33	○	○	—	—	○	—	—	—
38	○	○	—	—	○	—	—	—
39	○	○	—	—	○	—	—	—
3A	○	○	—	—	○	—	—	—
3B	○	○	—	—	○	—	—	—
40	○	○	○	—	○	—	—	—
41	○	○	○	—	○	—	—	—
42	○	○	○	—	○	—	—	—
43	○	○	○	—	○	—	—	—
48	○	○	○	—	○	—	—	—
49	○	○	○	—	○	—	—	—

CODE No.	HIGH VOLTAGE	POWER SUPPLY STOP			H-DEFLEC.	V-DEFLEC.	FAN MOTOR	EEPROM
		P1	P2	P3				
4A	—	—	○	—	—	○	—	○
4B	—	—	○	—	—	○	—	○
50	—	—	○	—	—	○	—	○
51	—	—	○	—	—	○	—	○
52	—	—	○	—	—	○	—	○
53	—	—	○	—	—	○	—	○
58	—	—	○	—	—	○	—	○
59	—	—	○	—	—	○	—	○
5A	—	—	○	—	—	○	—	○
5B	—	—	○	—	—	○	—	○
60	—	—	○	—	—	○	—	○
61	—	—	○	—	—	○	—	○
62	—	—	○	—	—	○	—	○
63	—	—	○	—	—	○	—	○
68	—	—	○	—	—	○	—	○
69	—	—	○	—	—	○	—	○
6A	—	—	○	—	—	○	—	○
6B	—	—	○	—	—	○	—	○
70	—	—	○	—	—	○	—	○
71	—	—	○	—	—	○	—	○
72	—	—	○	—	—	○	—	○
73	—	—	○	—	—	○	—	○
78	—	—	○	—	—	○	—	○
79	—	—	○	—	—	○	—	○
7A	—	—	○	—	—	○	—	○
7B	—	—	○	—	—	○	—	○
80	—	—	○	—	—	○	—	○
81	—	—	○	—	—	○	—	○
82	—	—	○	—	—	○	—	○
83	—	—	○	—	—	○	—	○
88	—	—	○	—	—	○	—	○
89	—	—	○	—	—	○	—	○
8A	—	—	○	—	—	○	—	○
8B	—	—	○	—	—	○	—	○
90	—	—	○	—	—	○	—	○
91	—	—	○	—	—	○	—	○
92	—	—	○	—	—	○	—	○
93	—	—	○	—	—	○	—	○
98	—	—	○	—	—	○	—	○
99	—	—	○	—	—	○	—	○
9A	—	—	○	—	—	○	—	○
9B	—	—	○	—	—	○	—	○
A0	—	—	○	—	—	○	—	○
A1	—	—	○	—	—	○	—	○
A2	—	—	○	—	—	○	—	○
A3	—	—	○	—	—	○	—	○
A8	—	—	○	—	—	○	—	○
A9	—	—	○	—	—	○	—	○
AA	—	—	○	—	—	○	—	○
AB	—	—	○	—	—	○	—	○
B0	—	—	○	—	—	○	—	○
B1	—	—	○	—	—	○	—	○
B2	—	—	○	—	—	○	—	○
B3	—	—	○	—	—	○	—	○
B8	—	—	○	—	—	○	—	○
B9	—	—	○	—	—	○	—	○
BA	—	—	○	—	—	○	—	○
B8	—	—	○	—	—	○	—	○
CO	—	—	○	—	—	○	—	○

CODE No.	HIGH VOLTAGE	POWER SUPPLY STOP			H-DEFLEC.	V-DEFLEC.	FAN MOTOR	EEPROM
		P1	P2	P3				
C1	—	—	○	○	○	—	—	—
C2	—	—	○	○	○	—	—	—
C3	—	—	○	○	○	—	—	—
C8	—	—	○	○	○	—	—	○
C9	—	—	○	○	○	—	—	○
CA	—	—	○	○	○	—	—	○
CB	—	—	○	○	○	—	—	○
D0	○	—	○	○	○	—	—	—
D1	○	—	○	○	○	—	—	—
D2	○	—	○	○	○	—	—	—
D3	○	—	○	○	○	—	—	—
D8	○	—	○	○	○	—	—	○
D9	○	—	○	○	○	—	—	○
DA	○	—	○	○	○	—	—	○
DB	○	—	○	○	○	—	—	○
E0	—	○	○	○	○	—	—	—
E1	—	○	○	○	○	—	—	—
E2	—	○	○	○	○	—	—	—
E3	—	○	○	○	○	—	—	—
E4	—	○	○	○	○	—	○	—
E5	—	○	○	○	○	—	○	—
E6	—	○	○	○	○	—	○	—
E7	—	○	○	○	○	—	○	—
E8	—	○	○	○	○	—	○	—
E9	—	○	○	○	○	—	○	—
EA	—	○	○	○	○	—	○	—
EB	—	○	○	○	○	—	○	—
EC	—	○	○	○	○	—	○	—
ED	—	○	○	○	○	—	○	—
EE	—	○	○	○	○	—	○	—
EF	—	○	○	○	○	—	○	—
F0	○	○	○	○	○	—	—	—
F1	○	○	○	○	○	—	—	—
F2	○	○	○	○	○	—	—	—
F3	○	○	○	○	○	—	—	—
F4	○	○	○	○	○	—	—	—
F5	○	○	○	○	○	—	—	—
F6	○	○	○	○	○	—	—	—
F7	○	○	○	○	○	—	—	—
F8	○	○	○	○	○	—	—	—
F9	○	○	○	○	○	—	—	—
FA	○	○	○	○	○	—	—	—
FB	○	○	○	○	○	—	—	—
FC	○	○	○	○	○	—	—	—
FD	○	○	○	○	○	—	—	—
FE	○	○	○	○	○	—	—	—
FF	○	○	○	○	○	—	—	—

Measurements and Adjustments

CONTENTS

	Page
ADJUSTMENT PROCEDURE FLOWCHART	30
LOCATION OF TEST POINTS AND CONTROLS	31
CAUTION FOR SERVICING.....	36
DC VOLTAGE CONFIRMATION	37
H.OSC FREQUENCY ADJUSTMENT	38
HIGH VOLTAGE CIRCUIT ADJUSTMENT	38
A. OVER-VOLTAGE PROTECT CIRCUIT ADJ.	38
B. HIGH VOLTAGE ADJ.	39
C. OVER-CURRENT PROTECT CIRCUIT ADJ.	40
CENTERING ADJUSTMENT	40
RASTER SIZE ADJUSTMENT	41
RGB CONVERGENCE ADJUSTMENT	41
RGB SUB BRIGHT & SUB CONTRAST ADJUSTMENT	43
CATHODE DC BIAS ADJUSTMENT	44
RGB WHITE BALANCE (LOW & HIGH) ADJUSTMENT	44
SCREEN VR ADJUSTMENT	46
VIDEO (NTSC) WHITE BALANCE (LOW & HIGH) ADJUSTMENT	46
VIDEO (NTSC) CONVERGENCE ADJUSTMENT	48
VIDEO (PAL) CONVERGENCE ADJUSTMENT	49
INSTALLATION and ADJUSTMENT PROCEDURE	50
1. Changing the main unit specifications	50
2. Standard setting-up positions	52
3. Changing the deflection	55
4. Setting-up and adjustment	56
REMOTE CONTROL OPERATION (Service mode) PROCEDURE	65

* Note: Before measuring and adjusting, operate the video projector over 60 minutes.

ADJUSTMENT PROCEDURE FLOWCHART

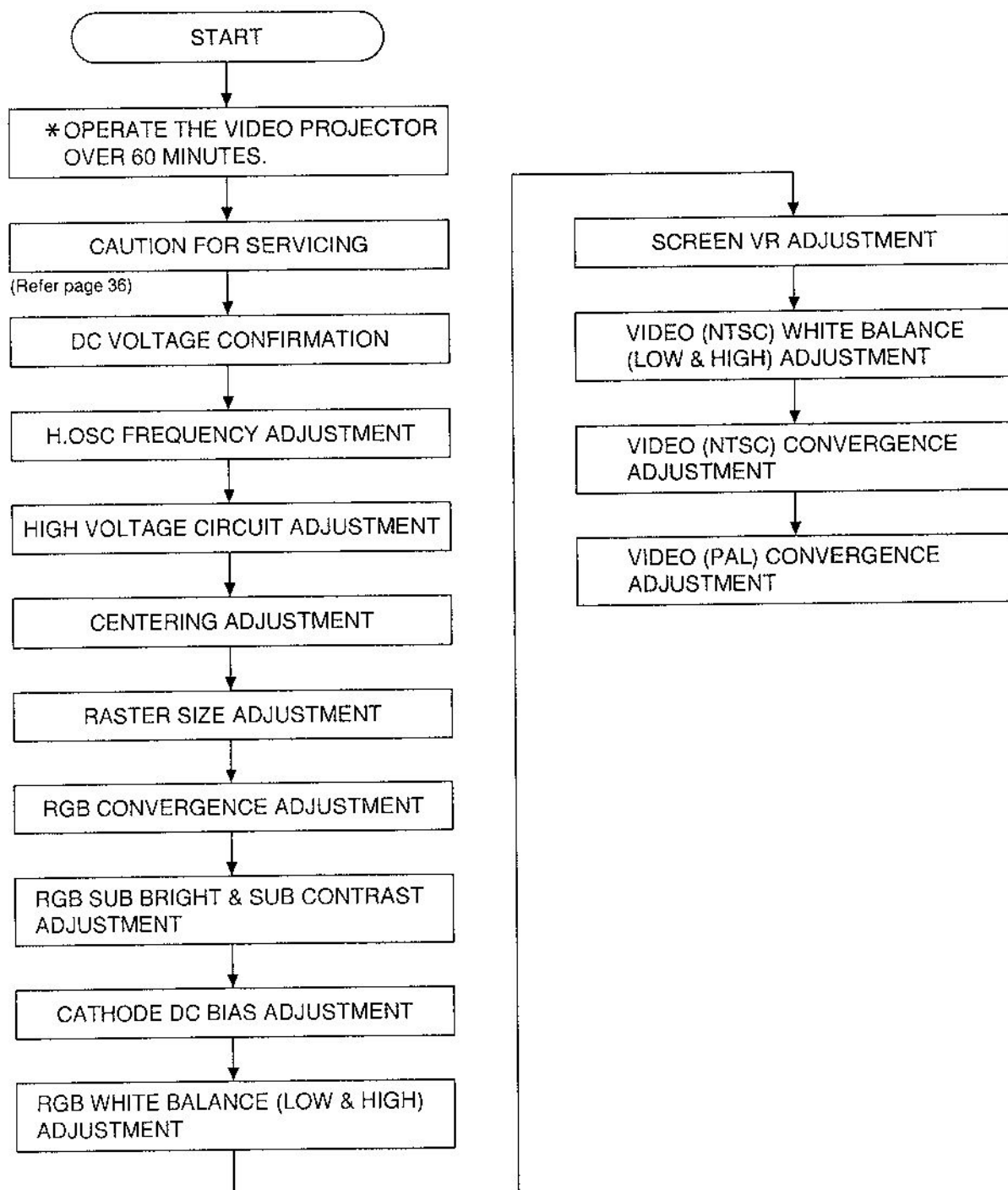

LOCATION OF TEST POINTS AND CONTROLS

P-P.C. Board

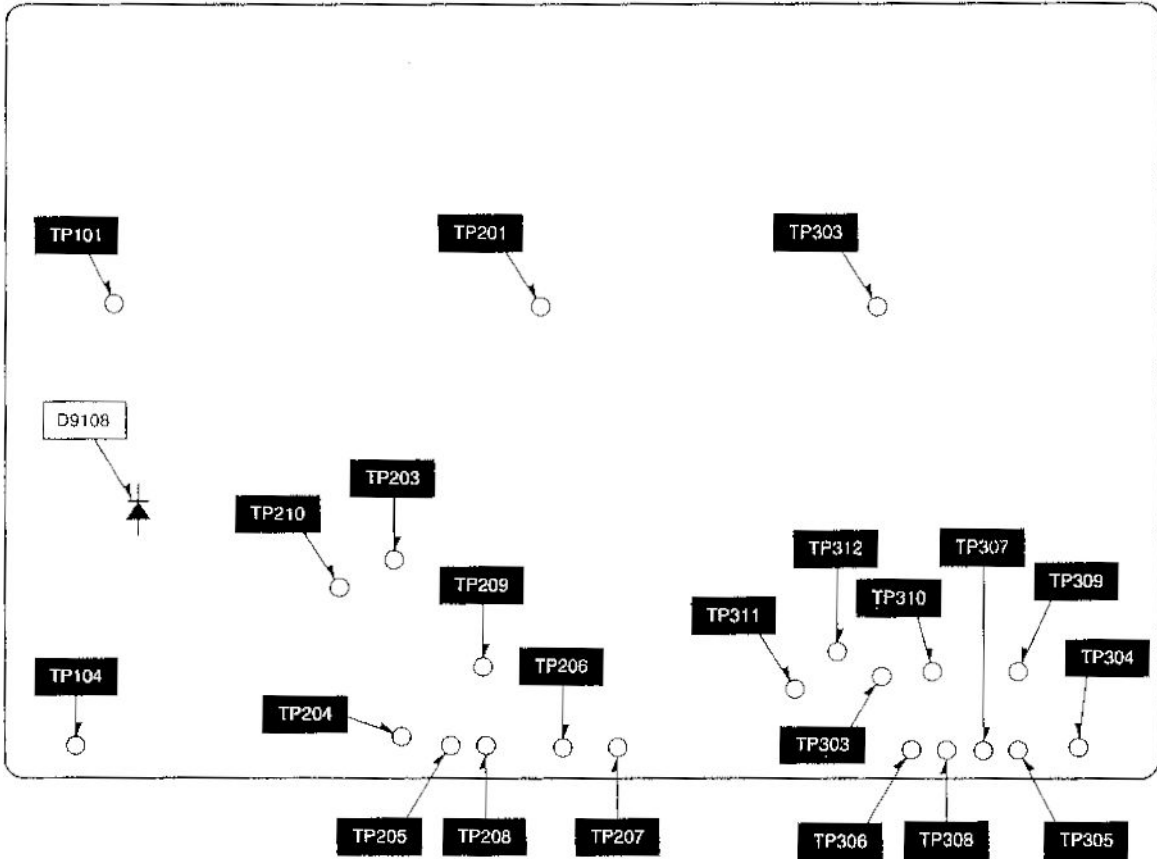

K-P.C. Board

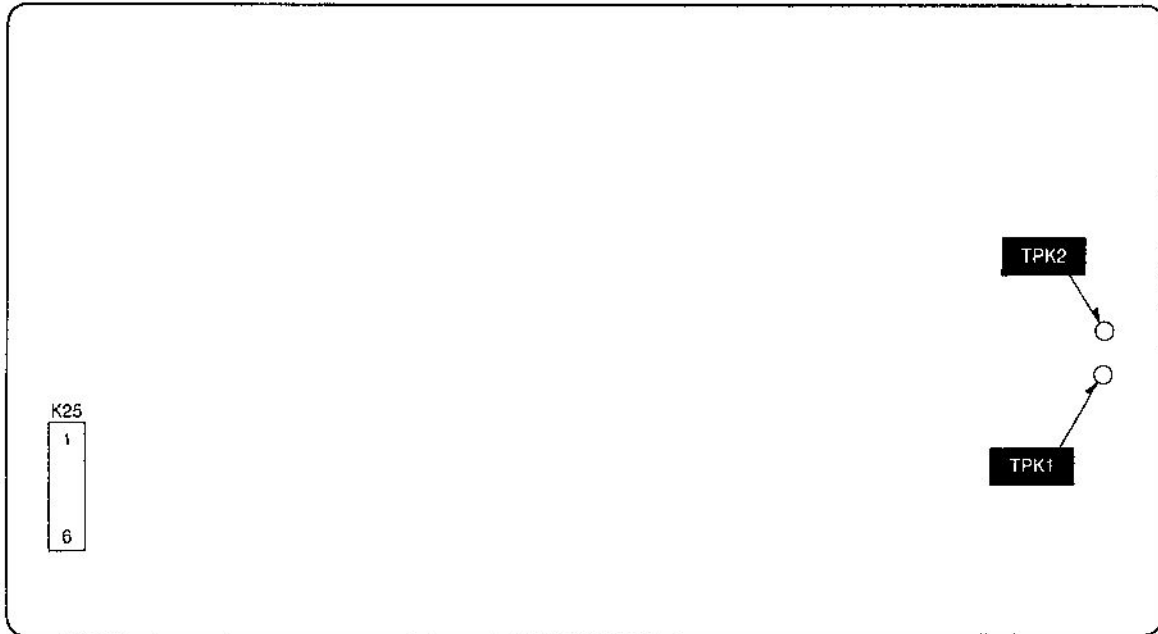

E-P.C. Board

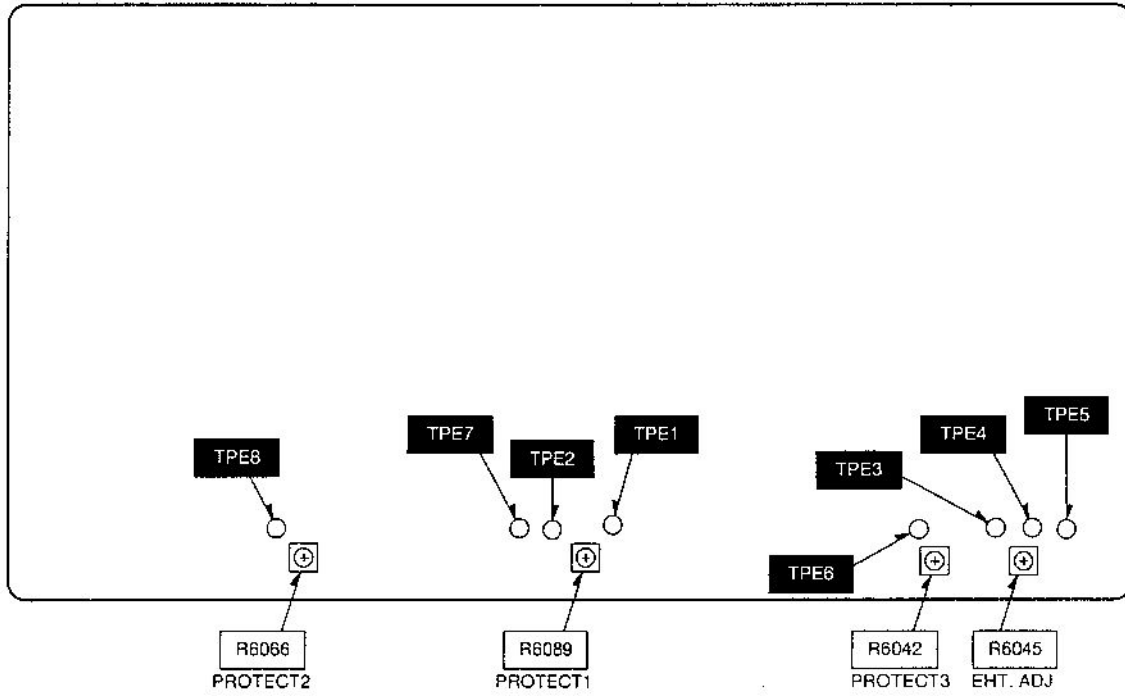

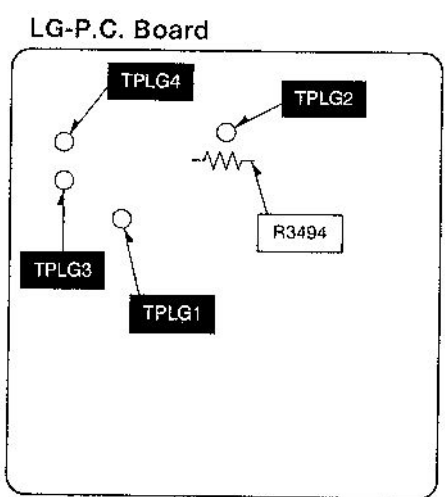
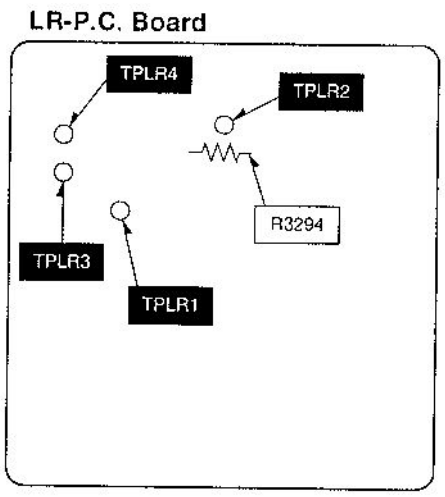
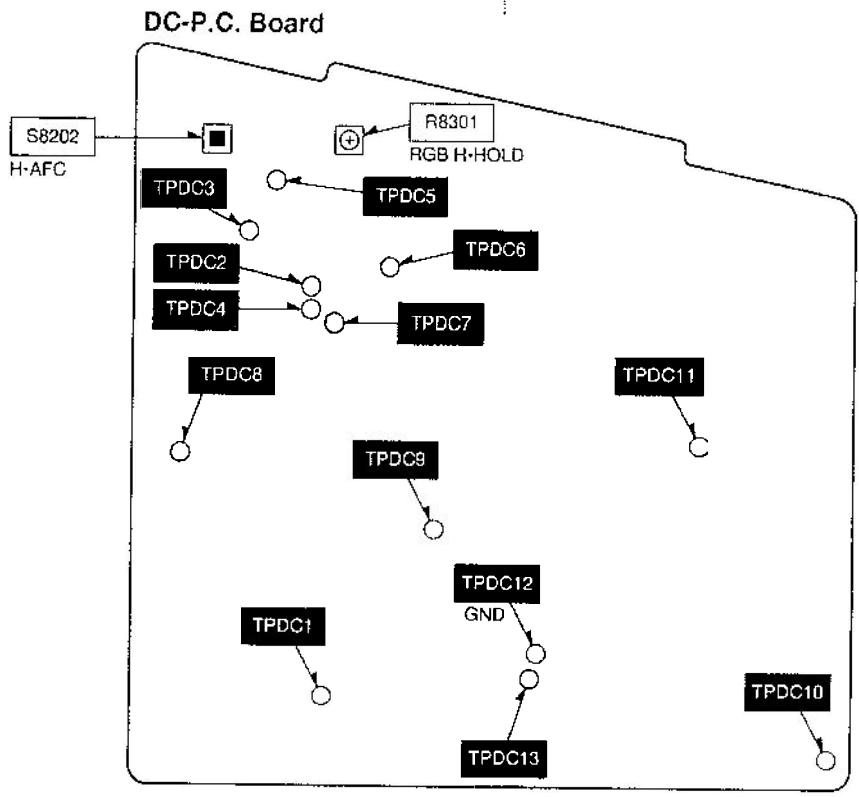

LY-P.C Board

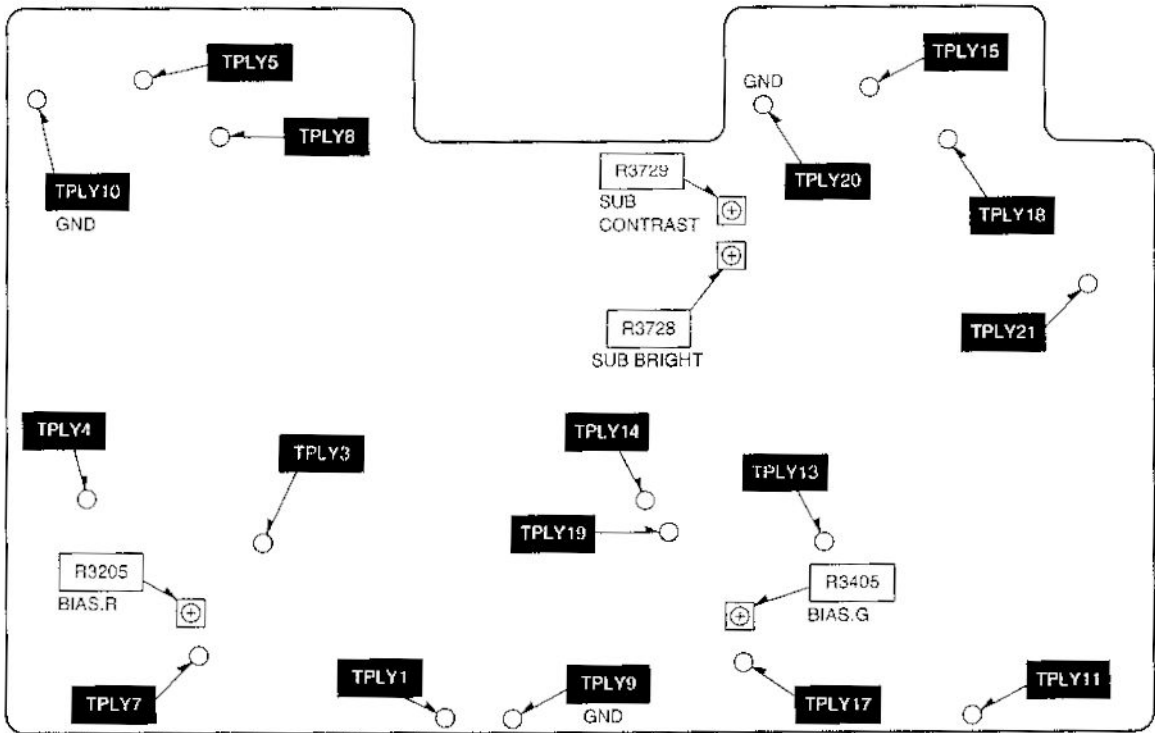

LC-P.C Board

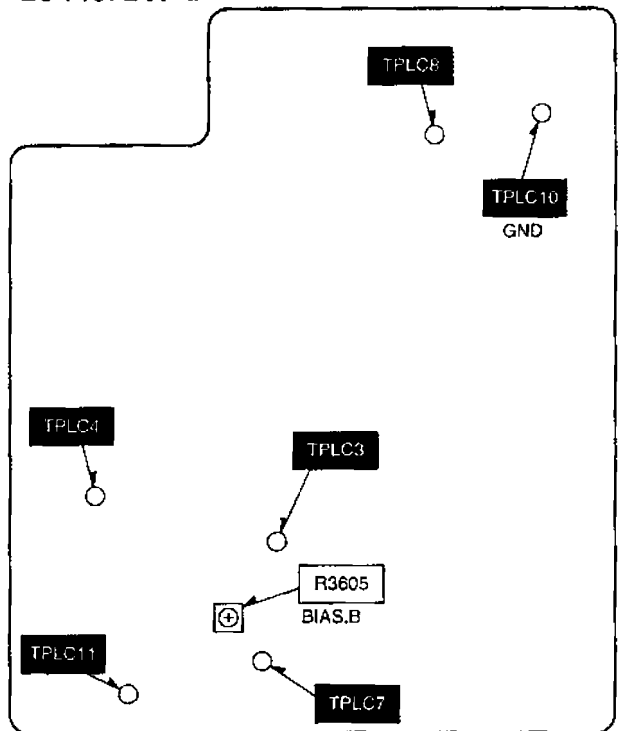

LB-P.C Board

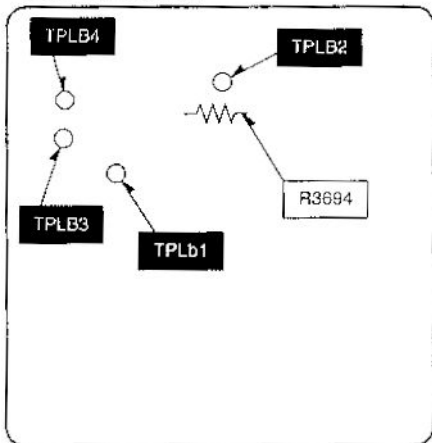

H-P.C. Board

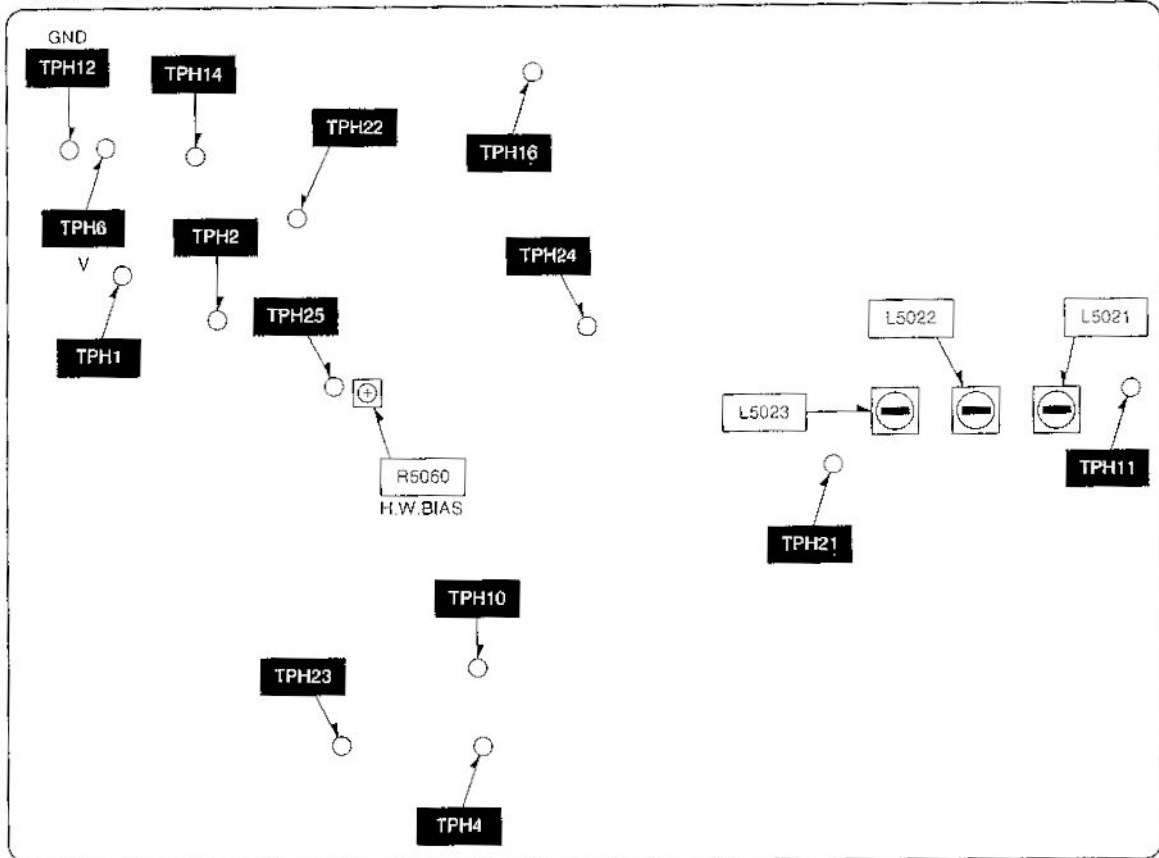

V-P.C. Board

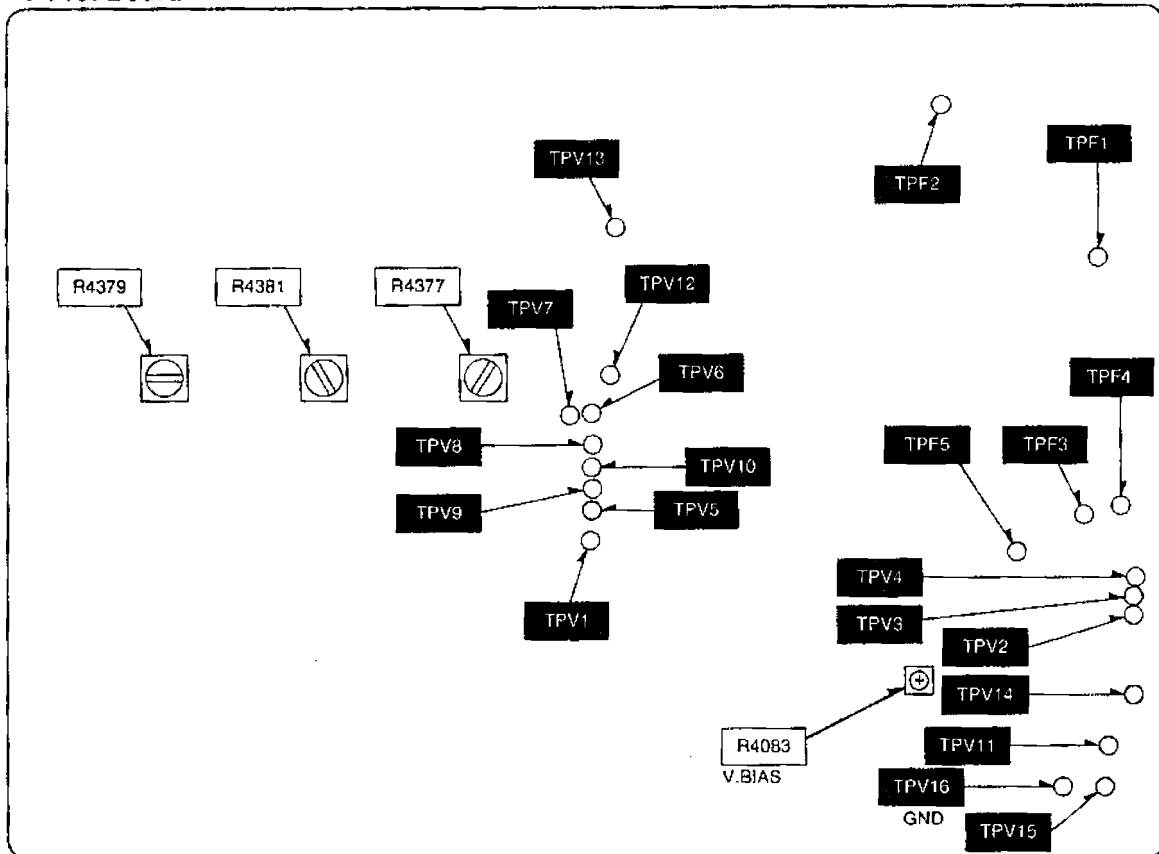

Caution for Servicing

Note 1: 1. When a screwing is needed during adjustment, use a non-metallic screw-driver to prevent unexpected short-circuits.

2. Transformer core position. (Application for both Field Adjustment and General alignment.)
Unless otherwise noted, a transformer core which has two tuning peak points should be adjusted at the lower position as shown in Fig. 1.

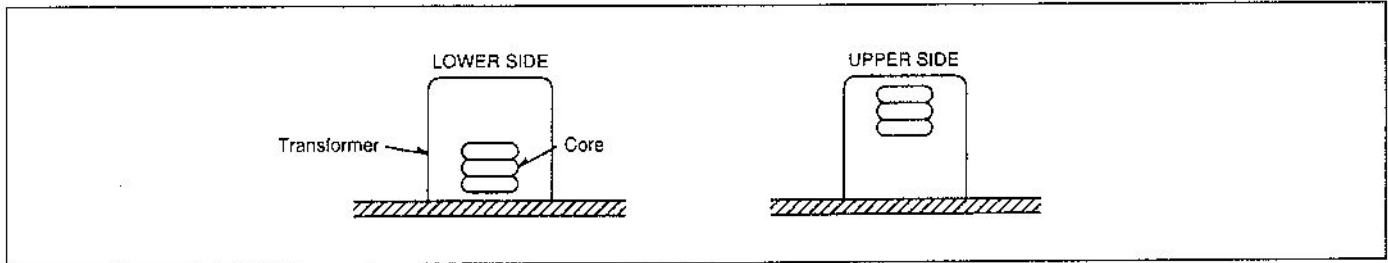

Fig. 1

Note 2: 1. Color video/data projector are badly affected by magnetic fields. All efforts must be made to keep transformers, iron plates, or anything else likely to distort the magnetic field well away from a color video/data projector. If magnetic influence is expected, steps should be taken to eliminate the magnetic field.

2. Input signals should be 1Vp-p video signal 0.3V synchronizing signal, standard (-10 dB) audio signal or 0.7Vp-p RGB signals with positive polarity, 0.7Vp-p \pm 3dB H.V. synchronizing signal with negative polarity.

Note 3: Adjustment should be done in the way of setting up on the floor and projection distance should be set as shown in Fig. 2.

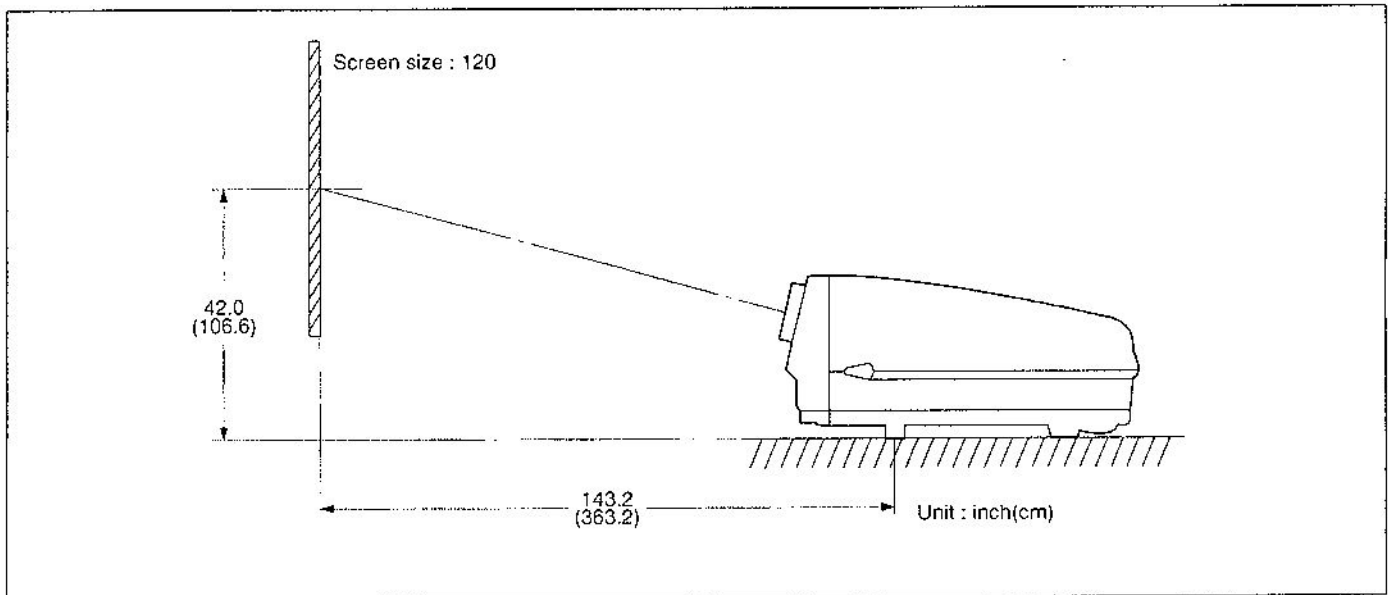

Fig. 2

DC VOLTAGE CONFIRMATION (K/P-P.C.Boards)

1. EQUIPMENT TO BE USED

Digital voltmeter
Programmable Signal Generator

2. CONFIRMATION PROCEDURE

1. Turn off the main power switch and power switch on control panel.
2. Input a monoscope pattern signal (fH=31.5kHz, fV=60Hz, NTSC) to RGB IN 1.

<K-P.C. Board>

3. Turn on the main power switch.
4. Connect a digital voltmeter between each measurement point as follows.

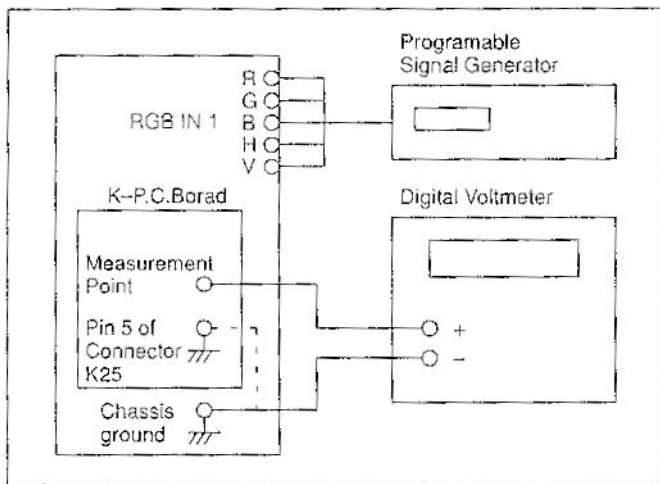

Fig. 3

5. Confirm that the indicated measurement points for the specified voltage as shown in Table 1.

Measurement Points	Voltage
TPK1	+12V ± 10V
TPK2	+5.6V ± 0.3V

Table 1

6. Turn on the power switch.
7. Connect a digital voltmeter from chassis ground to Pin 5 of connector K25.
8. Confirm that the indicated measurement points for the specified voltage as shown in Table 2.

Measurement Points	Voltage
Pin 6 of connector K25	+335V ± 10V
Pin 1 of connector K25	+47V ± 5V
Pin 2 of connector K25	+47V ± 5V
Pin 3 of connector K25	+47V ± 5V

Table 2

9. Disconnect a digital voltmeter.

<P-P.C. Board>

10. Connect a digital voltmeter between each measurement point as follows.

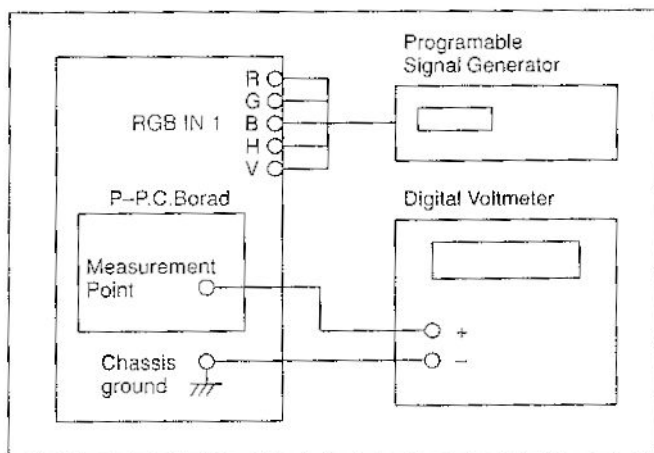

Fig. 4

11. Confirm that the indicated measurement points for the specified voltage as shown in Table 3.

Measurement Points	Voltage
Ⓚ side of D9108	+14.0V ± 1.0V
TP104	+160.0V ± 2.0V
TP204	+198.0V ± 2.0V
TP205	-8.8V ± 0.5V
TP206	+18.0V ± 1.0V
TP207	+8.4V ± 0.5V
TP208	-18.0V ± 1.0V
TP304	+115.5V ± 2.0V
TP305	+17.0V ± 1.0V
TP306	+35.5V ± 1.0V
TP307	-36.6V ± 1.0V
TP308	-17.5V ± 1.0V

Table 3

H.OSC FREQUENCY ADJUSTMENT (H/DC-P.C.Boards)

1. EQUIPMENT TO BE USED

Digital Voltmeter
Programmable Signal Generator
Frequency Counter

2. ADJUSTMENT PROCEDURE

1. Input a monoscope pattern signal ($f_H=58\text{KHz}$, $f_V=60\text{Hz}$) to RGB IN 1.
2. Connect a digital voltmeter to TPH6 and TPH12 (GND) on the H-P.C.Board.
3. Confirm that the FV voltage (TPH6) becomes $5.60\text{V} \pm 0.1\text{V}$.

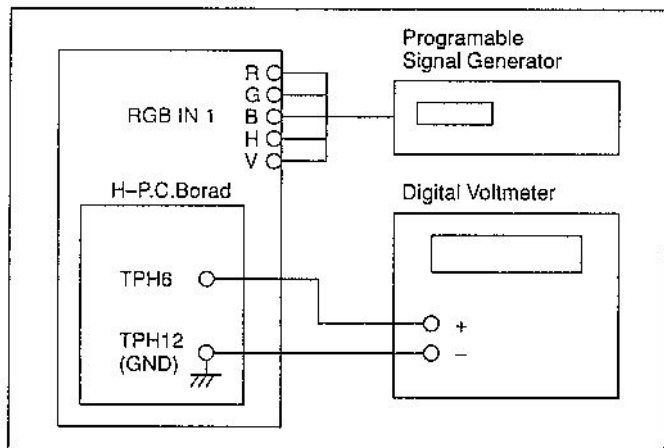

Fig. 5

4. Connect a frequency counter to TPH14 and TPH12 (GND) on the H-P.C. Board.
5. Set the H.AFC. ON/OFF SW (S8202) on the DC-P.C.Board to Non-Push mode.
6. Adjust R8301 (RGB H-HOLD) on the DC-P.C.Board so that the frequency counter shows $57.5 \pm 0.1\text{kHz}$.
7. Set the H.AFC. ON/OFF SW (S8202) to Push mode.
8. Confirm that the H-Sync is holding.
9. Input a monoscope pattern signal ($f_H=15.75\text{KHz}$, $f_V=60\text{Hz}$) to RGB IN 1.
10. Turn to TEST mode by using the remote controller.
11. Turn the control pattern switch on the remote controller to SERVICE and press the CUT OFF button. Next, turn the control pattern button to NORMAL, and press the buttons in the order of 1 → 5 → 6 → 5.
12. Turn the control pattern switch on the remote controller to SERVICE, and press the CENTERING button.
13. Set the H.AFC ON/OFF SW (S8202) on the DC-P.C.Board to Non-Push mode.
14. Adjust the CONTROL LEVEL KEY (+, -) on the remote control so that the picture is synchronized.
15. Set the H.AFC ON/OFF SW (S8202) on the DC-P.C.Board to Push mode.
16. Confirm that the H-Sync is holding.
17. Push the STORE button on the remote control.

18. Input a monoscope pattern signal ($f_H=93\text{KHz}$, $f_V=60\text{Hz}$) to RGB IN 1.
19. Execute procedures described on Items 9 - 16 likewise.
20. Press the ESC button on the remote controller to return to NORMAL mode.

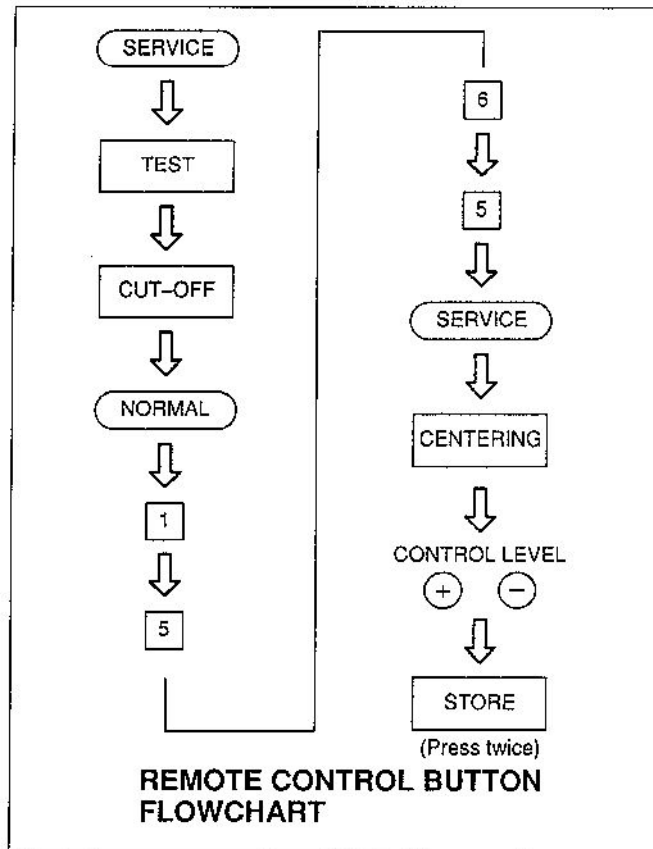

Fig. 6

HIGH VOLTAGE CIRCUIT ADJUSTMENT (E-P.C.Board)

A. OVER-VOLTAGE PROTECT CIRCUIT ADJ.

1. EQUIPMENT TO BE USED

High Voltage Meter
Digital voltmeter
Programmable Video Generator

2. ADJUSTMENT PROCEDURE

1. Turn off the main power switch and power switch.
2. Fully turn R6045 (EHT. ADJ.) counterclockwise on the E-P.C.Board.
3. Input a full white pattern signal ($f_H=31.5\text{kHz}$, $f_V=60\text{Hz}$) to LINE IN.
4. Connect a high voltage meter to high voltage distributor.
5. Connect a digital voltmeter between TPE1 (+) and TPE2 (-).

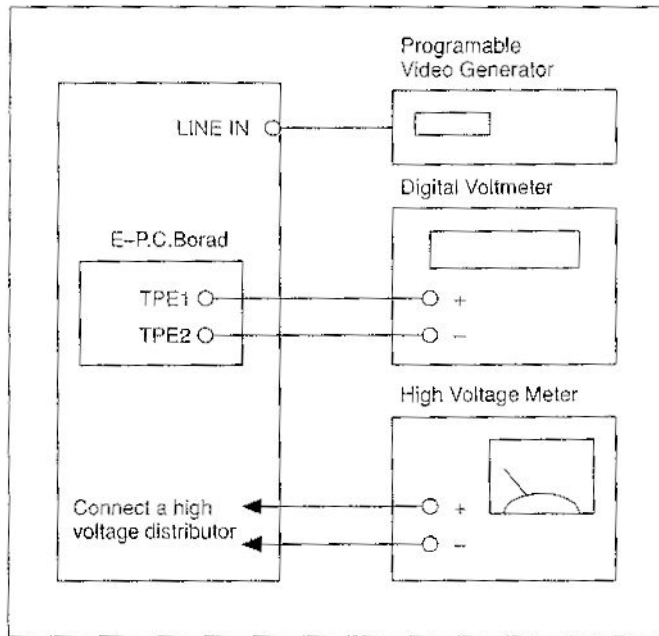

Fig. 7

6. Turn on the main power switch and power switch on control panel.
7. Adjust R6045 (EHT. ADJ.), CONTRAST and BRIGHT controls so that the value of high voltage is $34\text{kV} \pm 0.3\text{kV}$ and value of DC voltage is $1.9\text{V} \pm 0.1\text{V}$.
8. Adjust R6066 (PROTECT 2) slowly clockwise until shut-down occurs and hold that position.
9. Fully turn R6045 (EHT. ADJ.) counterclockwise.
10. Turn off the main power switch, then re-turn on it.
11. Adjust R6045 (EHT. ADJ.) slowly clockwise until shut-down occurs High Voltage should be $34\text{kV} \pm 0.5\text{kV}$, and $1.9\text{V} \pm 0.1\text{V}$ on the voltage meter just before shut-down.
12. If the reading in Step 11 are not confirmed, repeat Steps 1 to 11.
13. Fully turn R6045 (EHT. ADJ.) counterclockwise.
14. Input all black pattern signal to LINE IN.
15. Set the CONTRAST and BRIGHT of the picture adjustment to minimum for deep black picture.
16. Adjust R6045 (EHT. ADJ.) so that the value of high voltage is $34\text{kV} \pm 0.3\text{kV}$.
17. Adjust R6089 (PROTECT 1) slowly clockwise until shut-down occurs and hold that position.
18. Fully turn R6045 (EHT. ADJ.) counterclockwise.
19. Turn off the main power switch, then re-turn on it.
20. Adjust R6045 (EHT. ADJ.) slowly clockwise until shut-down occurs High Voltage should be $34\text{kV} \pm 0.5\text{V}$.
21. If the reading in Step 21 are not confirmed, repeat Steps 13 to 21.

22. Cover R6066 (PROTECT 2) and R6089 (PROTECT 1) with the sleeve, and secure them in place with silicon bond as shown below.

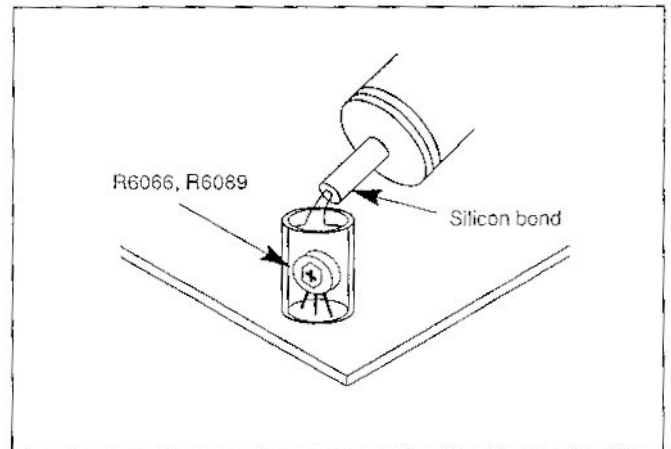

Fig. 8

B. HIGH VOLTAGE ADJ.

1. EQUIPMENT TO BE USED

- High Voltage Meter
- Programmable Video Generator

2. ADJUSTMENT PROCEDURE

1. Turn off the main power switch and power switch on control panel.
2. Input a full black pattern signal to LINE IN.
3. Connect a high voltage meter to high voltage distributor.
4. Turn on the main power switch and power switch.
5. Set the CONTRAST and BRIGHT of the picture adjustment to minimum for deep black picture.
6. Adjust R6045 (EHT. ADJ.) on the E-P.C. Board so that the value of high voltage is $32\text{kV} \pm 0.5\text{kV}$.
7. Input a full white pattern signal to LINE IN.
8. Set the CONTRAST and BRIGHT of the picture adjustment to maximum.
9. Confirm that the value of high voltage is $32\text{kV} \pm 0.5\text{kV}$.
10. Cover R6045 (EHT. ADJ.) with sleeve, and secure it in place with silicon bond.

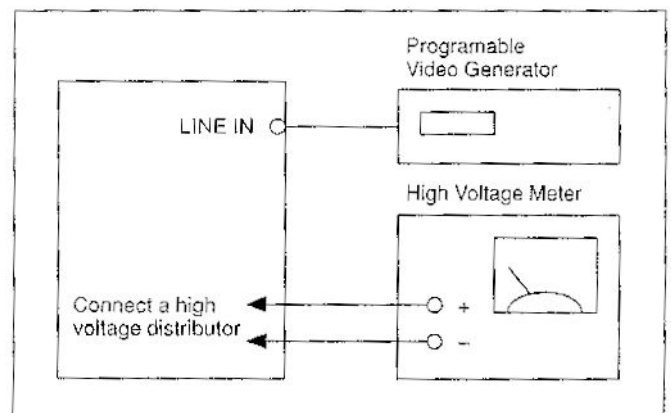

Fig. 9

C. OVER-CURRENT PROTECT CIRCUIT ADJ.

1. EQUIPMENT TO BE USED

Digital Voltmeter
Programmable Video Generator

2. INITIAL CONDITION (on screen value)

CONTRAST MAXIMUM
BRIGHT MAXIMUM

3. ADJUSTMENT PROCEDURE

1. Input a full white pattern signal ($f_H=31.5\text{kHz}$, $f_V=60\text{Hz}$) to LINE IN.
2. Connect a digital voltmeter between TPE1 (+) and TPE2 (-).
3. Confirm that the value of voltage is $2.1\text{V} \pm 0.2\text{V}$.
4. Connect a digital voltmeter between TPE6 (+) and TPE5 (-).
5. Adjust R6042 (PROTECT 3) on the E-P.C.Board so that the value of voltage is $1.5\text{V} \pm 0.1\text{V}$.
6. Cover R6042 (PROTECT 3) with sleeve, and secure it in place with silicon bond.

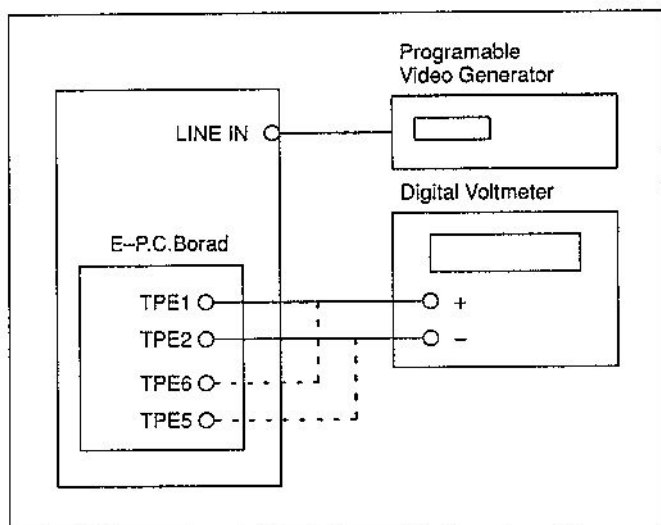

Fig. 10

CENTERING ADJUSTMENT (V-P.C.Board)

1. EQUIPMENT TO BE USED

Programmable Signal Generator
Remote Control

Note : For remote control operation, see REMOTE CONTROL OPERATION PROCEDURE to be described later.

2. INITIAL CONDITION (on screen value)

BRIGHT 128
CONTRAST 190
CENTERING 128
CONVERGENCE 128

3. ADJUSTMENT PROCEDURE

1. Input a circular pattern signal ($f_H=31.5\text{kHz}$, $f_V=60\text{Hz}$) in RGB IN 1.
2. Press the TEST button on the remote control so that the crosshair pattern is displayed on the screen.
3. Adjust angles of deflection coils of R, G and B so that the horizontal line in the center of picture may run parallel with the horizontal line of the screen display surface.
4. Make sure that deviations between crosshair pattern horizontal axes of R, G and B and horizontal directions on the screen display surface are not beyond the numerical values described in Table 4.

	(mm)
R	± 184
G	± 73
B	± 184

Table 4

5. Make sure that deviations between crosshair pattern vertical axes of R, G and B and vertical directions on the screen display surface do not exceed $\pm 100\text{mm}$.

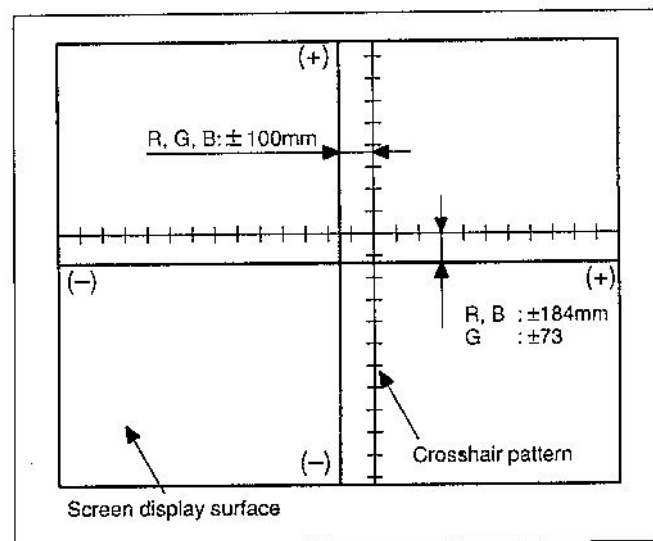

Fig. 11

6. Adjust the CENTERING on the remote controller so that green horizontal line may lie nearly halfway between red and blue horizontal lines. (DAC value: 50~200)
7. Put the lens caps on the red and blue lenses.
8. Adjust R4083 (V. BIAS) so that the center of green cross-hair pattern may be placed 25 mm below the vertical center of screen display surface. (Adjust R4083.)
9. Adjust the CENTERING button on the remote controller so that green crosshair pattern may be placed in the center of horizontal direction of screen display surface.

10. Press the STORE button on the remote controller.
11. Remove the lens caps from the red and blue lenses.
12. Adjust the CENTERING on the remote controller so that the red and blue cross patterns may conform with the green crosshair pattern.
13. Press the STORE button twice on the remote control.
14. Press the ESC button on the remote control.

RASTER SIZE ADJUSTMENT (H/DA-P.C.Boards)

1. EQUIPMENT TO BE USED

Programmable Signal Generator
Digital Voltmeter
Remote Control

Note: For remote control operation, see REMOTE CONTROL OPERATION PROCEDURE to be described later.

2. INITIAL CONDITION (on screen value)

BLANKING (BLK) ALL MAX

3. ADJUSTMENT PROCEDURE

1. Input a circular pattern signal (fH=31.5KHz, fV=60Hz) to RGB IN 1.
2. Connect a digital voltmeter between TPH25 and TPH12 (GND).
3. Put the lens caps on the red and blue lenses.
4. Press the RASTER SIZE button on the remote controller and set the numerical values of H and V as follows.
H : 128 V : 170
5. Press the STORE button on the remote control.
6. Adjust the RGB POSITION (V) on the remote controller so that the circular pattern may be placed in the center of screen display surface.

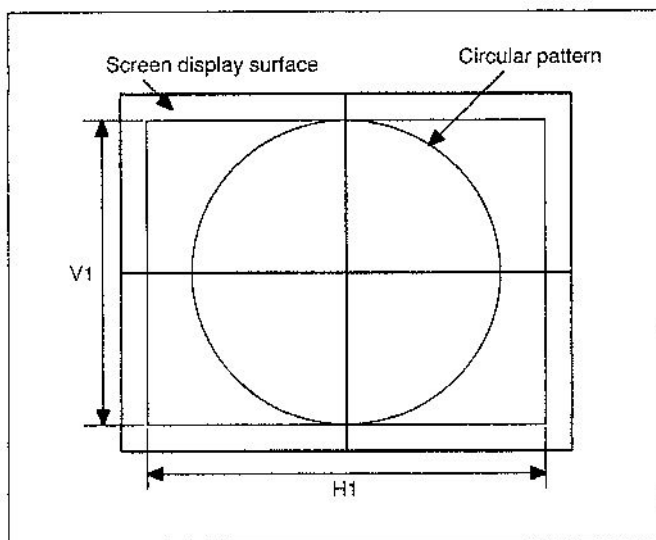

Fig. 12

7. Adjust R8975 (V.SIZE) on the DA-P.C.Board so that the V-size of V1 is 1736mm.
8. Remove the lens caps from the red and blue lenses.
9. Adjust R5060 (H.W.BIAS) on the H-P.C.Board so that the value of voltage is $0 \pm 0.01V$.
10. Secure R5060 in place with silicon bond.
11. Adjust the RGB POSITON (H) on the remote controller so that the center of right and left of picture may be placed in the center of screen display surface.
12. Adjust horizontal linearity by using the RASTER LIN on the remote controller.
13. Adjust the RASTER SIZE on the remote control so that the H-SIZE of H1 is 2314mm.
14. Input a circular pattern signal (fH=15.75KHz, fV=60Hz) to RGB IN 1.
15. Adjust horizontal linearity by using the RASTER LIN on the remote controller.
16. Confirm that the H-SIZE of H1 is $2246 \pm 157mm$.
17. Input a circular pattern signal (fH=65KHz, fV=60Hz) to RGB IN 1.
18. Adjust horizontal linearity by using the RASTER LIN on the remote controller.
19. Confirm that the H-SIZE of H1 is $2271 \pm 159mm$.
20. Input a circular pattern signal (fH=100KHz, fV=60Hz) to RGB IN 1.
21. Adjust horizontal linearity by using the RASTER LIN on the remote controller.
22. Confirm that the H-SIZE of H1 is $2143 \pm 150mm$.

RGB CONVERGENCE ADJUSTMENT

1. EQUIPMENT TO BE USED

Programmable Signal Generator
Remote Control

Note: For remote control operation, see REMOTE CONTROL OPERATION PROCEDURE to be described later.

2. INITIAL CONDITON (on screen value)

BRIGHT 128
CONTRAST MAX
RASTER SIZE H: 128, V: 160

3. ADJUSTMENT PROCEDURE

1. Input a circular pattern signal (fH=31.5KHz, fV=60Hz) to RGB IN 1.
2. Put the lens caps on the red and blue lenses.
3. Adjust the vertical and horizontal linearity of the picture image by the RASTER LIN on the remote control.
4. Press the TEST button on the remote control so that the crosshair pattern is displayed on the screen.
5. Adjust the vertical and horizontal centering of the green picture segment by the CENTERING on the remote control.

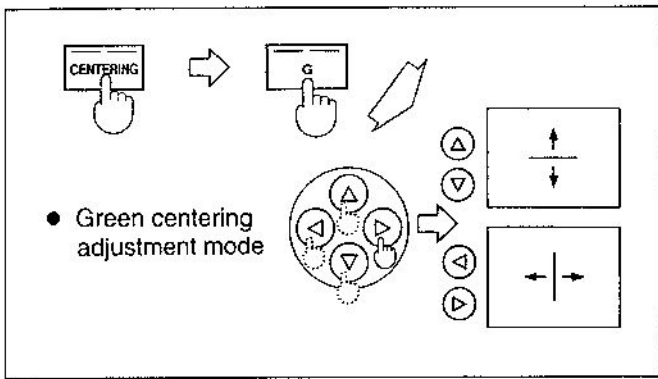

Fig. 13

6. Adjust the skewness and bowing of the green picture segment by the SKEW and BOW on the remote control.

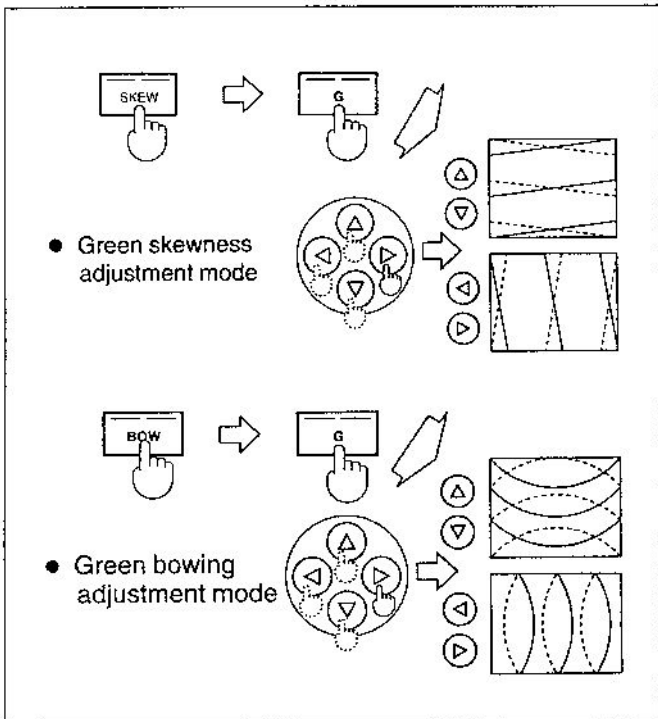

Fig. 14

7. Repeat adjustments described on Steps 5 and 6, and adjust so that they may overlap the center of screen display surface.
8. Press the STORE button twice on the remote control.
9. Press the TEST button so that the crosshatch pattern is displayed on the screen.
10. Adjust the keystone and balance of the green picture segment by the KEYSTONE and KEYSTONE BALANCE on the remote control.

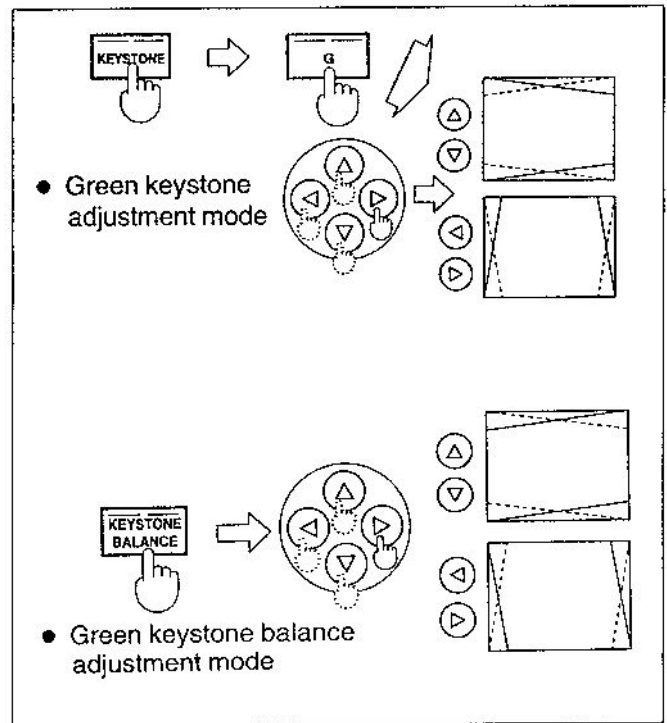

Fig. 15

11. Adjust the pin cushion distortion of the green picture segment by the PIN on the remote control.

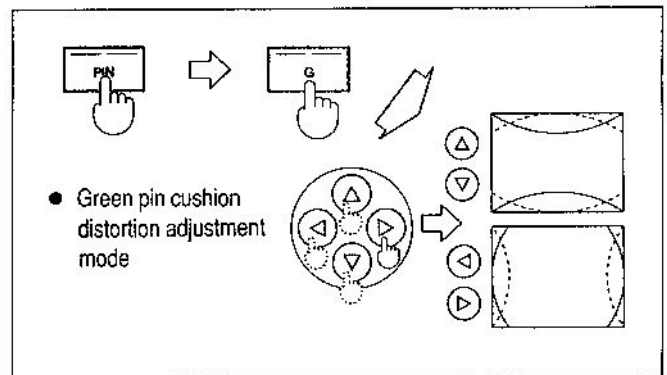

Fig. 16

12. Press the STORE button twice on the remote control.
13. Press the ZONE button on the remote control.
14. Referring to "REMOTE CONTROL OPERATION PROCEDURE : 22 ZONE button", adjust zone convergence of the green segment.

Note:

For ZONES 18, 19, 20 and 21, no adjustment are required generally. However, when there is a great difference between hatch intervals in the center and periphery parts, adjust ZONES 18, 19, 20 and 21 so that DAC value may be "ZONE 2 - 128 = 128 - ZONE 3"

15. Press the STORE button twice on the remote control.
16. Adjust the RASTER SIZE on the remote control so that the vertical size is 1736mm.
17. Confirm that the DAC value of vertical is 160 ± 10 .
18. Adjust the RASTER SIZE on it so that the horizontal size is 2314mm. Confirm that the DAC value of horizontal is 128 ± 50 .
19. Press the STORE button twice on it.
20. Remove the lens caps from the red and blue lenses.

<RED CONVERGENCE ADJ.>

21. Adjust red convergence by pressing the buttons on the remote controller in the order as shown in Fig. 17 below.

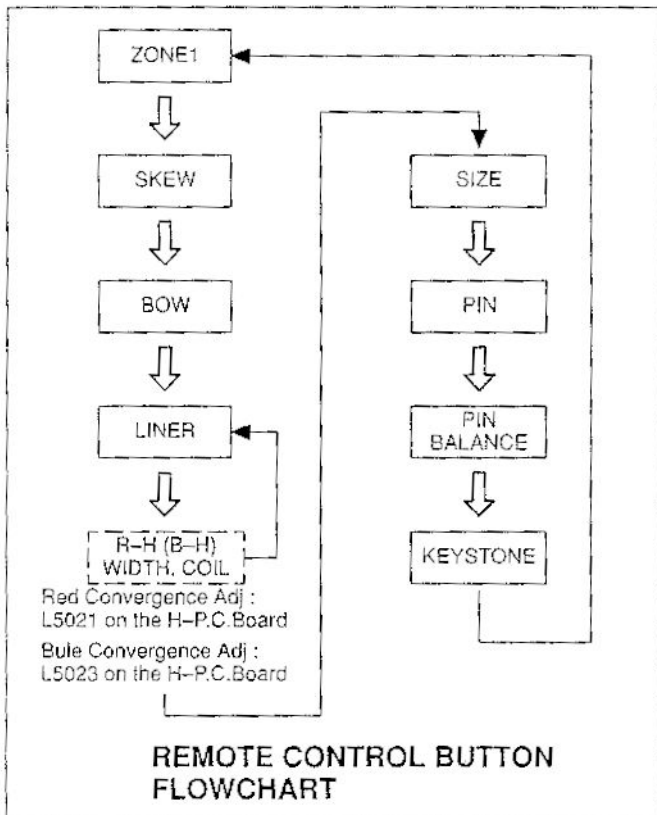

Fig. 17

22. Press the ZONE button on the remote control.
23. Adjust zone convergence by using ZONE 1 to ZONE 21.
24. When 1 span in the left end of vertical line can not be adjusted by all means, adjust R4377 and R4381 on the V-P.C.Board.

<BLUE CONVERGENCE ADJ.>

25. Do the same adjustment as red convergence adjustment described on Steps 21 to 23.
26. When 1 span in the left end of vertical line can not be adjusted by all means, adjust R4379 on the V-P.C.Board.

Note:

1. Confirm that the skew (V) DAC values of the red, blue and green picture segments are 128 ± 10 . If they are beyond the said numerical value, readjust inclination of DY.
2. Confirm that differences between the red, blue and green segments and DAC values of ZONES 10 - 21 do not exceed 128 ± 50 . If they are beyond the said value, readjust convergence.
3. Confirm that differences between the red, blue and green segments and DAC values of ZONES 18 - 21 do not.

27. Press the STORE button twice on it.

RGB SUB BRIGHT & SUB CONTRAST ADJUSTMENT (LY/LC-P.C.Board)

1. EQUIPMENT TO BE USED

- Digital Voltmeter
- Oscilloscope
- Programmable Signal Generator

2. INITIAL CONDITION (on screen value)

- BRIGHT 128
- CONTRAST MAX

3. ADJUSTMENT PROCEDURE

1. Input a crosshatch pattern signal ($f_H=31.5kHz$, $f_V=60Hz$) to RGB IN 1.
2. Connect a digital voltmeter between TPLC11 (+) and TPLC10 (-).
3. Connect an oscilloscope to TPLC7 and GND.

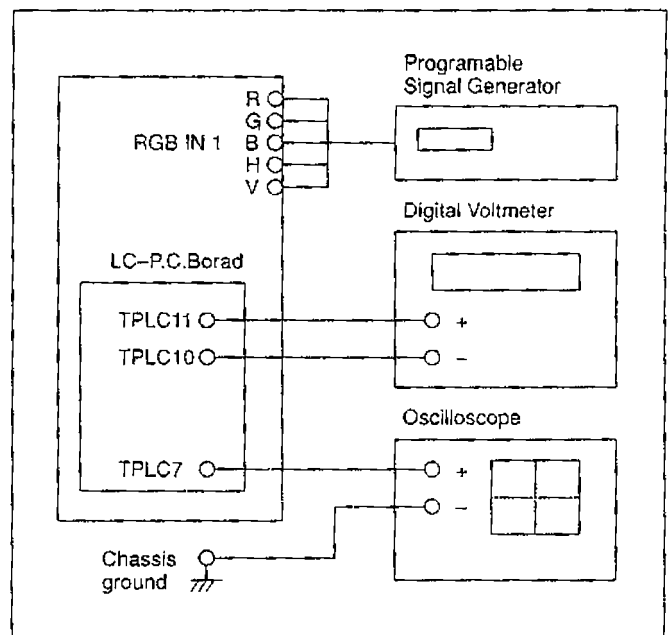

Fig. 18

- Adjust R3729 (SUB CONTRAST) on the LY-P.C.Board so that the value of a voltmeter is $200\text{mV} \pm 10\text{mV}$.
- Adjust R3728 (SUB BRIGHT) on it so that the voltage of the bright pulse is $0 \pm 5\text{mV}$.

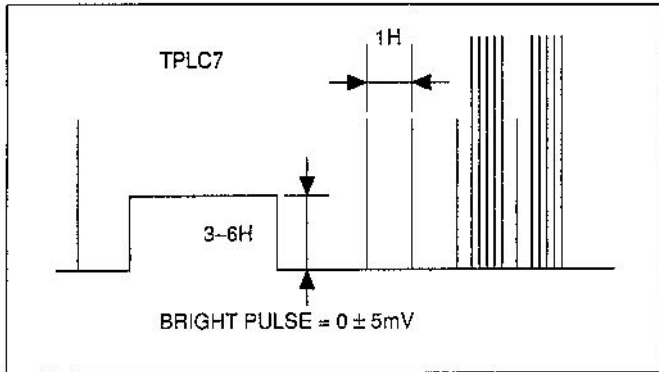

Fig. 19

CATHODE DC BIAS ADJUSTMENT (LR/LG/LB-P.C. Boards)

1. EQUIPMENT TO BE USED

Oscilloscope
Programmable Signal Generator

2. INITIAL CONDITION (on screen value)

BRIGHT 128
CONTRAST MAX

3. ADJUSTMENT PROCEDURE

- Input a crosshatch pattern signal ($f_H=31.5\text{kHz}$, $f_V=60\text{Hz}$) to RGB IN 1.
- Connect an oscilloscope to TPLR1.

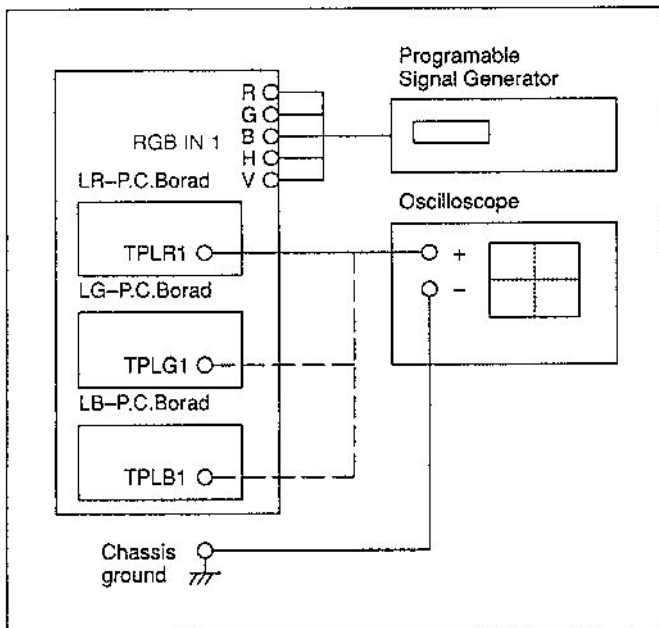

Fig. 20

- Adjust R3205 (R.BIAS) on the LY-P.C.Board so that the cathode DC bias is $+170\text{V} \pm 5\text{V}$ DC level.
- Connect an oscilloscope to TPLG1.
- Adjust R3405 (G.BIAS) on the LY-P.C.Board so that the cathode DC bias is $+170\text{V} \pm 5\text{V}$ DC level.
- Connect an oscilloscope to TPLB1.
- Adjust R3605 (B.BIAS) on the LC-P.C.Board so that the cathode DC bias is $+170\text{V} \pm 5\text{V}$ DC level.

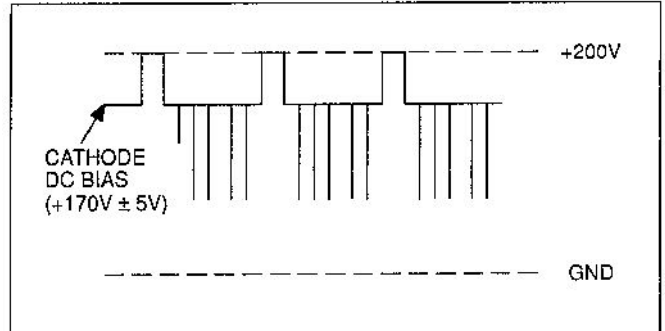

Fig. 21

RGB WHITE BALANCE (LOW & HIGH) ADJUSTMENT

1. EQUIPMENT TO BE USED

Oscilloscope
Programmable Signal Generator
Color Analyzer
Remote Control

Note: For remote control operation, see REMOTE CONTROL OPERATION PROCEDURE to be described later.

2. INITIAL CONDITION (on screen value)

COLOR MID
BRIGHT 128
CONTRAST MAX

3. ADJUSTMENT PROCEDURE

- Input a white window pattern signal ($f_H=31.5\text{kHz}$, $f_V=60\text{Hz}$) to RGB IN 1.

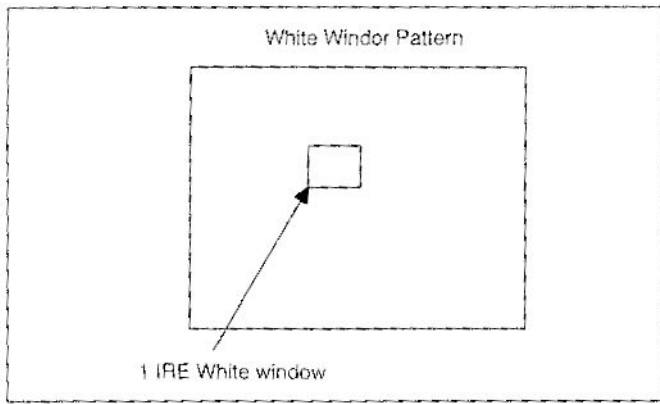

Fig. 22

2. Connect an oscilloscope to TPLY8 on the LY-P.C. Board.

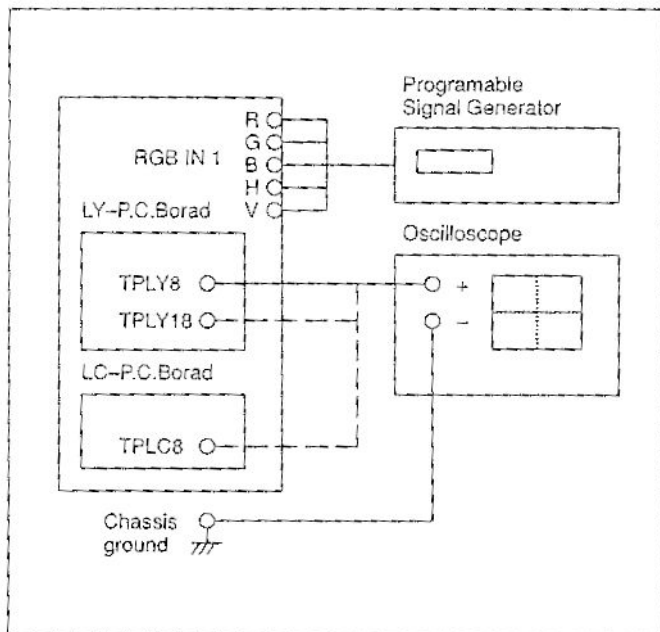

Fig. 23

3. Adjust Screen VR (R) so that G1 voltage is about -10V DC level.

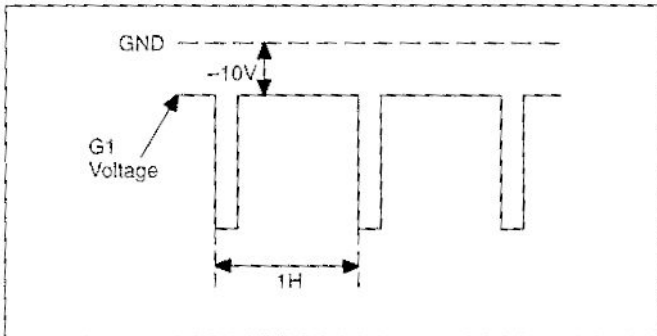

Fig. 24

4. Connect an oscilloscope to TPLY18 on the LY-P.C. Board.
5. Adjust Screen VR (G) so that G1 voltage is about -10V DC level.
6. Connect an oscilloscope to TPLC8 on the LC-P.C. Board.
7. Adjust Screen VR (B) so that G1 voltage is about -10V DC level.
8. Adjust the CONTRAST on the remote control so that the DAC value of CONTRAST is 190.
9. Disconnect an oscilloscope.
10. Press the TEST button on the remote control.
11. Press the WB-HIGH button on it.
12. By using the color analyzer, adjust DAC values of (R) highlight and (B) highlight at WB-HIGH mode so that white chromaticity coordinates on the screen may be "x=0.3180 and y=0.3540".
However, adjustment of DAC value of (G) highlight is not required.
13. Press the WB-LOW button on it.
14. Adjust each DAC value at WB-LOW mode to the following values.
R = 155 G = 128 B = 225
15. Press the WB-HIGH button on it.
16. Press the buttons on the remote controller as shown in Fig. 25 below.

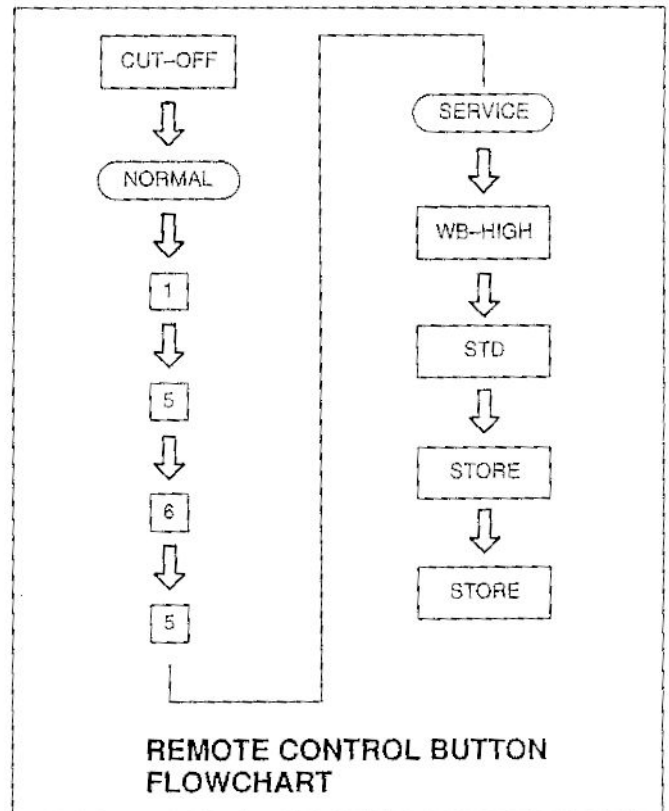

Fig. 25

17. On the basis of DAC value of COLOR TEMP (Rm, Gm, Bm): MID, input DAC values of COLOR TEMP HIGH/LOW at each WB-HIGH mode as shown in Table 5.

COLOR TEMP	DAC Value of WB-HIGH		
	R	G	B
HIGH	Rm -10	Gm -23	Bm
MID	Rm	Gm	Bm
LOW	Rm +55	Gm	Bm -48

Table 5

18. Press the STORE button twice on the remote control.

SCREEN VR ADJUSTMENT (LY/LC-P.C.Boards)

1. EQUIPMENT TO BE USED

Oscilloscope
Programmable Signal Generator

2. INITIAL CONDITION (on screen value)

COLOR TEMP MID
BRIGHT 128
CONTRAST MAX

3. ADJUSTMENT PROCEDURE

1. Input a crosshatch pattern signal ($f_H=31.5\text{kHz}$, $f_V=60\text{Hz}$) to RGB IN 1.
2. Connect an oscilloscope to TPLY8 on the LY-P.C.Board.
3. Adjust Screen VR (R) so that G1 voltage is $-10\text{V}\pm 2\text{V}$ DC level.

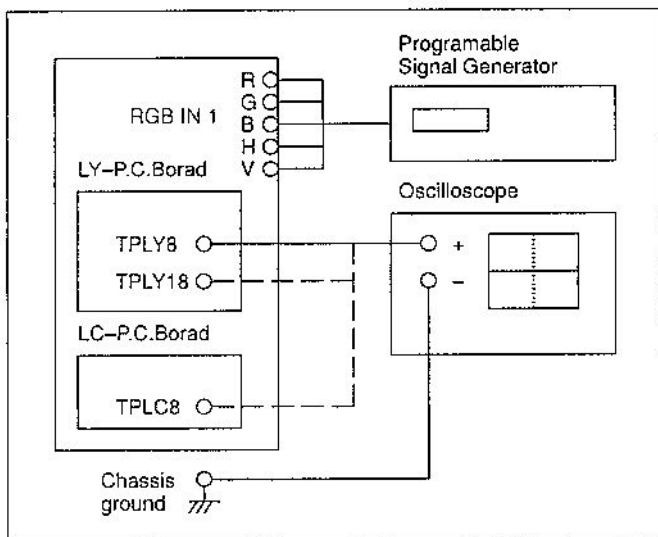

Fig. 26

4. Connect an oscilloscope to TPLY18 on the LY-P.C.Board.
5. Adjust Screen VR (G) so that G1 voltage is $-10\text{V}\pm 2\text{V}$ DC level.
6. Connect an oscilloscope to TPLC8 on the LC-P.C.Board.
7. Adjust Screen VR (B) so that G1 voltage is $-10\text{V}\pm 2\text{V}$ DC level.
8. Secure each Screen VR in place with silicon bond.

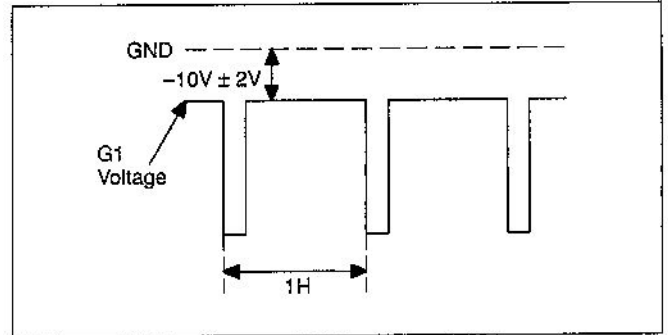

Fig. 27

VIDEO (NTSC) WHITE BALANCE (LOW & HIGH) ADJUSTMENT

1. EQUIPMENT TO BE USED

Oscilloscope
Programmable Video Generator
Color Analyzer
Remote Control

Note: For remote control operation, see REMOTE CONTROL OPERATION PROCEDURE to be described later.

2. INITIAL CONDITION (on screen value)

LINE AUTO
COLOR TEMP MID
BRIGHT 128
CONTRAST 190

3. ADJUSTMENT PROCEDURE

1. Input a white window pattern signal to LINE IN.

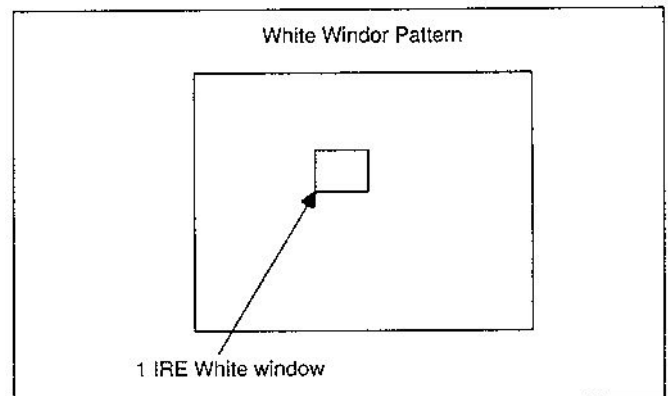

Fig. 28

2. When the probe of oscilloscope is connected, disconnect it.
3. Press the TEST button on the remote control.
4. Press the WB-HIGH button on it.
5. By using the color analyzer, adjust DAC values of (R) and (B) at WB-HIGH mode so that white chromaticity coordinates on the screen may be "x=0.3180 and y=0.3540.
However, adjustment of DAC value of (G) is not required.
6. Press the WB-LOW button on it.
7. Adjust each DAC value at WB-LOW mode to the following values.
R = 155 G = 128 B = 225
8. Press the WB-HIGH button on it.
9. Press the buttons on the remote controller in the order as shown in Fig. 29 below.

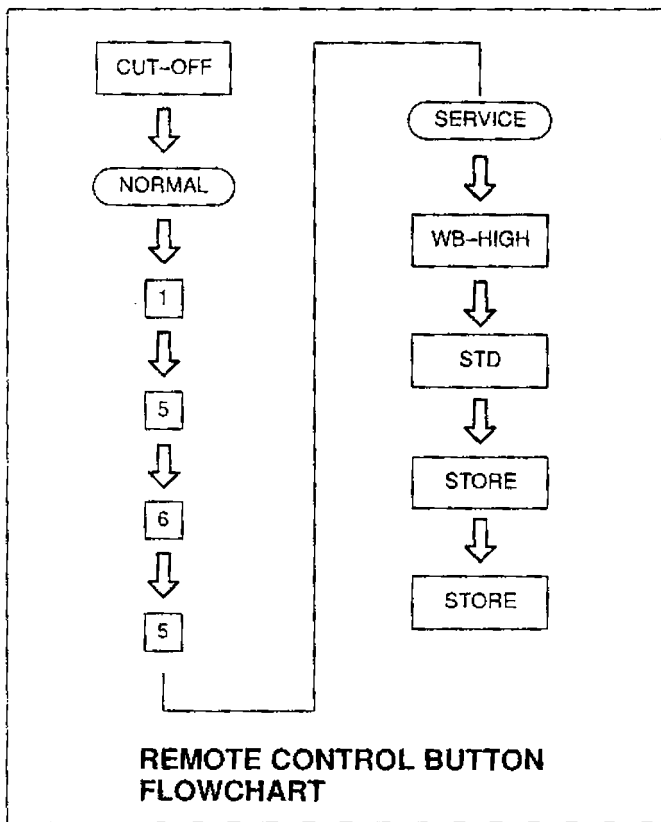

Fig. 29

10. On the basis of DAC value of COLOR TEMP (Rm, Gm, Bm): MID, input DAC values of COLOR TEMP: HIGH/LOW at each WB-HIGH mode as shown in Table 6.

COLOR TEMP	DAC Value of WB-HIGH		
	R	G	B
HIGH	Rm -8	Gm -18	Bm
MID	Rm	Gm	Bm
LOW	Rm +48	Gm	Bm -56

Table 6

11. Press the STORE button twice on the remote control.
12. Adjust initial condition as follows. (on screen value)
COLOR TEMP : MID
BRIGHT : 128
CONTRAST : MAX
13. Input a crosshatch pattern signal to LINE IN.
14. Connect an oscilloscope to TPLB1 on the LB-P.C.Board.

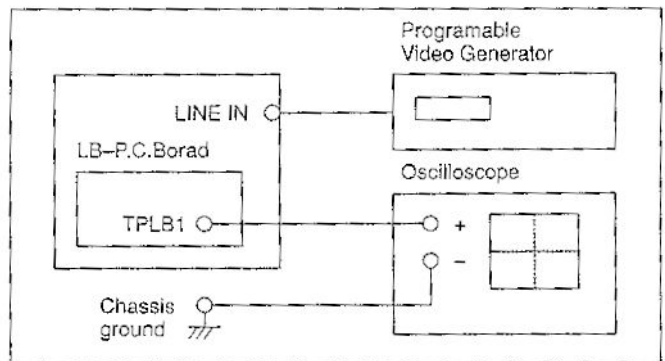

Fig. 30

15. Make sure whether or not B cathode voltage level exceeds 140Vp-p.

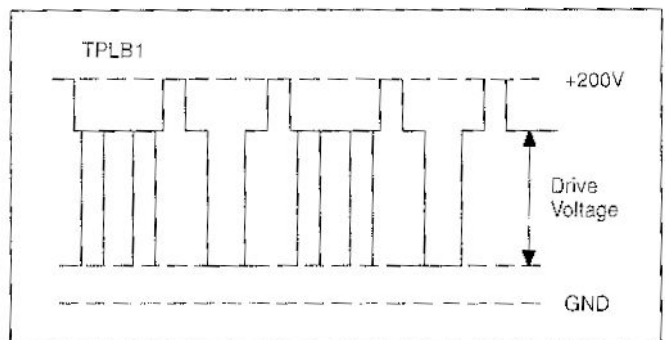

Fig. 31

16. If it exceeds 140Vp-p, adjust it to the said value by using R3729 (SUB CONTRAST).

VIDEO CONVERGENCE (NTSC) ADJUSTMENT

1. EQUIPMENT TO BE USED

Programmable Video Generator
Remote Control

Note: For remote control operation, see REMOTE CONTROL OPERATION PROCEDURE to be described later.

2. INITIAL CONDITION (on screen value)

BRIGHT 128
CONTRAST 190

3. ADJUSTMENT PROCEDURE

1. Input a monoscope pattern (NTSC) signal to LINE IN.
2. Put the lens caps on the red and blue lenses.
3. Press the TEST button on the remote control so that the crosshatch pattern is displayed on the screen.
4. Adjust the keystone (orthogonality) of the green picture segment by the KEYSTONE on the remote control.
5. Press the TEST button on it so that the Normal screen (monoscope pattern) is displayed on the screen.
6. Adjust the vertical and horizontal linearity of the picture image by the RASTER LIN.

7. Adjust the RASTER SIZE on the remote control so that the V- size of the picture screen is V=4.0 and the H-size of the picture screen is H=5.5.
8. Adjust the BLK on it so that the V-blanking is V=5.0 and the H-blanking is H=6.5.
9. Press the TEST button so that the crosshatch pattern is displayed on the screen.
10. Press the ZONE button.
11. Referring to "REMOTE CONTROL OPERATION PROCEDURE: 22 ZONE button", adjust zone convergence of the green segment.
12. Remove the lens caps from the red and blue lenses.
13. Adjust Red convergence by using the remote controller.
14. Adjust Blue convergence by using the remote controller.
15. Press the STORE button twice.
16. Press the ESC button.

VIDEO CONVERGENCE (PAL) ADJUSTMENT

1. EQUIPMENT TO BE USED

Programmable Video Generator
Remote Control

Note: For remote control operation, see REMOTE CONTROL OPERATION PROCEDURE to be described later.

2. INITIAL CONDITION (on screen value)

BRIGHT 128
CONTRAST 190

3. ADJUSTMENT PROCEDURE

1. Input a monoscope pattern (PAL) signal to LINE IN.
2. Put the lens caps on the red and blue lenses.
3. Press the TEST button on the remote control so that the crosshatch pattern is displayed on the screen.
4. Adjust the keystone (orthogonality) of the green picture segment by the KEYSTONE on the remote control.
5. Press the TEST button on it so that the Normal screen (monoscope pattern) is displayed on the screen.
6. Adjust the vertical and horizontal linearity of the picture image by the RASTER LIN.

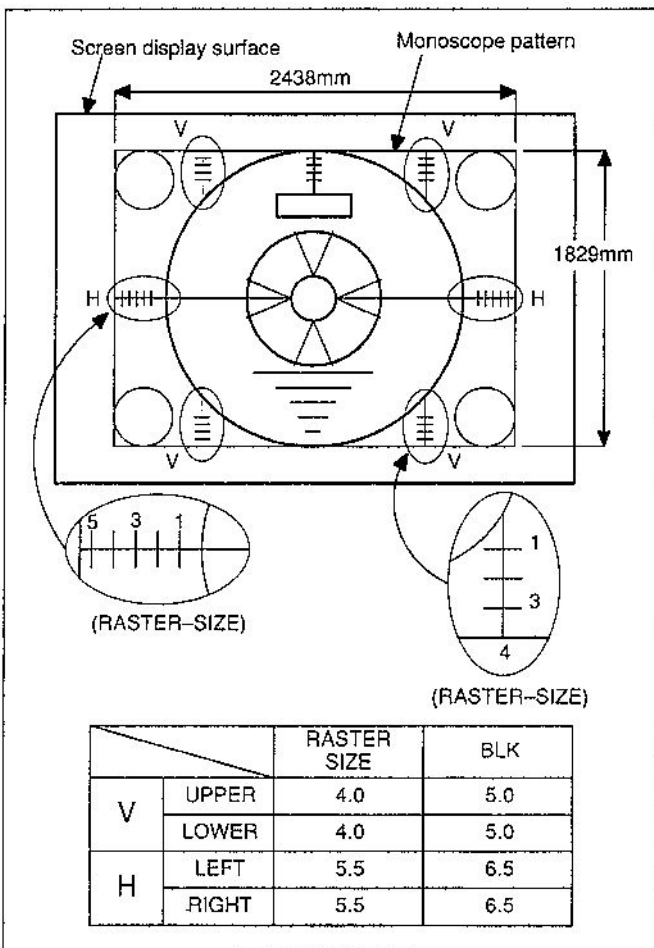

Fig. 32

7. Adjust the RASTER SIZE on the remote control so that the V-size of the picture screen is $V=4.0$ and the H-size of the picture screen is $H=5.5$.
8. Adjust the BLK on it so that the V-blanking is $V=5.0$ and the H-blanking is $H=6.5$.

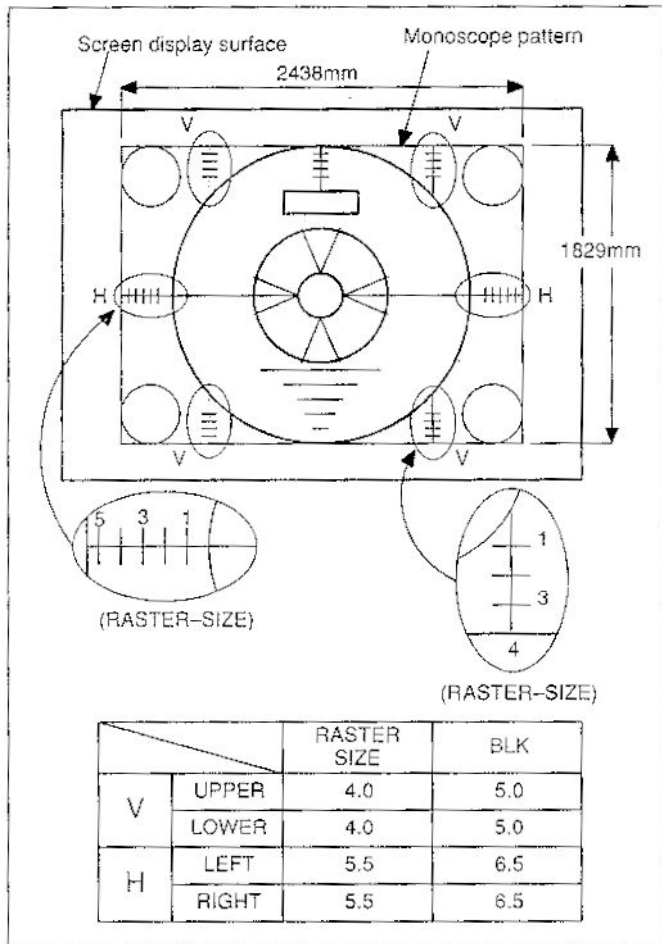

Fig. 33

9. Press the TEST button so that the crosshatch pattern is displayed on the screen.
10. Press the ZONE button.
11. Referring to "REMOTE CONTROL OPERATION PROCEDURE: 22 ZONE button", adjust zone convergence of the green segment.
12. Remove the lens caps from the red and blue lenses.
13. Adjust Red convergence by using the remote controller.
14. Adjust Blue convergence by using the remote controller.
15. Press the STORE button twice.
16. Press the ESC button.

INSTALLATION and ADJUSTMENT PROCEDURE

1. Changing the main unit specifications

At the time of shipment from the factory, the lens spacers and lens angles are set for use with 80~120-inch screens. If using a screen which is larger or smaller than this, the following adjustment is necessary.

NOTE:

- The magnetic Phillips driver with an 8-inch (20-cm) or longer shaft is necessary for this procedure.

① Open the cover.

② Remove the four screws, and then remove the X-ray cover above the projection lenses.

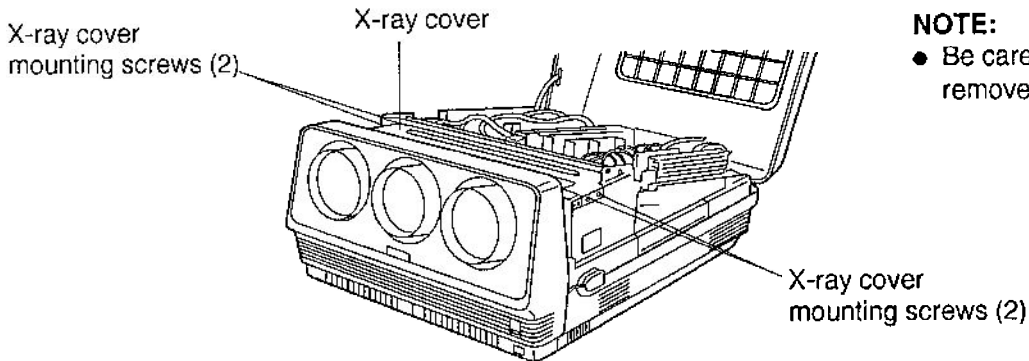

③ Remove the six screws, and then remove the front grille.

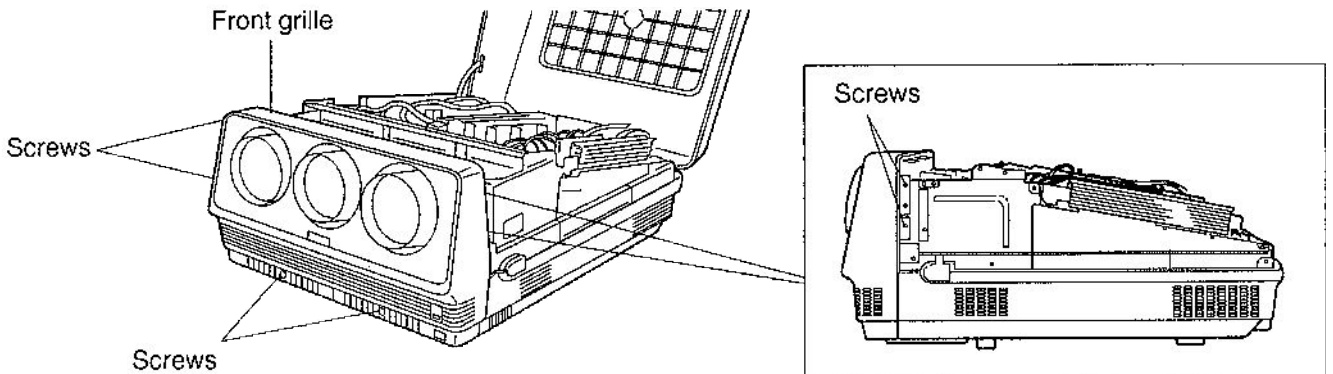

④ Remove the 12 lens mounting screws, and then remove the lenses and spacers.

NOTE:

- Be careful not to drop the removed screws into the projector.

⑤ Remove the four screws shown in the illustration that secure the red (R) and blue (B) CRTs.

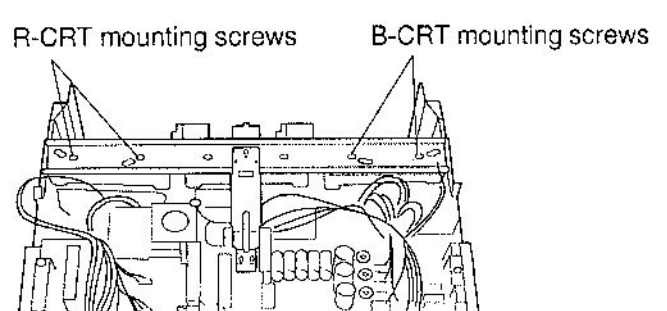
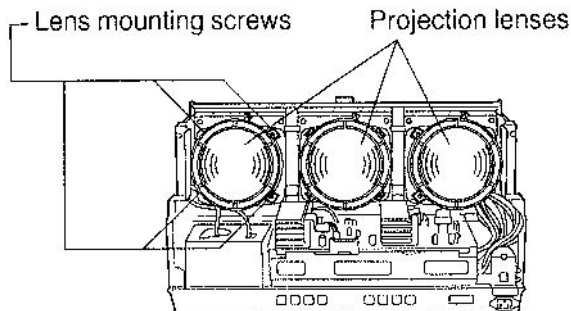

- ⑤ Use a screwdriver with a long shaft to loosen the four screws (black) which secure the lower sections of the CRTs, and then move the red and blue CRTs.

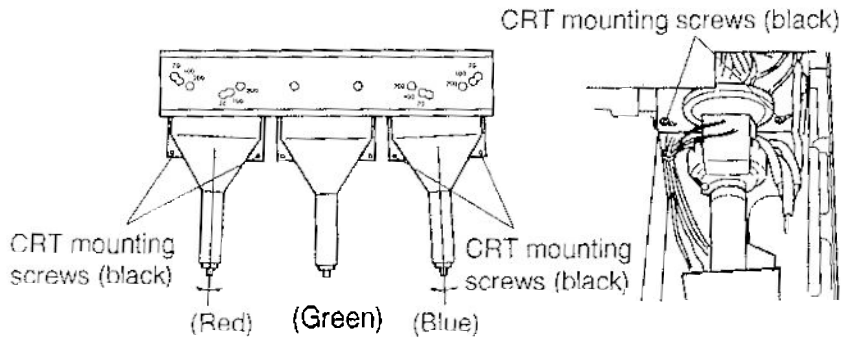

NOTE:

- The screws should only be loosened; they must not be fully removed.
- If the CRTs are difficult to move, try loosening the mounting screws that are securing the green (G) CRT.

- ⑥ While referring to the table below, adjust the positions of the CRTs to the indication that matches the desired projection screen size. (The brackets which hold the CRTs are marked with numbers as shown in the illustration above.) Once the position of a CRT has been determined, secure the CRT by tightening the CRT mounting screws. Furthermore, install the correct spacers to match the size of the screen. Select the spacers by referring to the table below.

Screen size	Indication	Lens spacers	
		Front	Rear
60~79	70	70 F	70 R
80~120	100	100 F	100 R
121~300	200	200 F	200 R

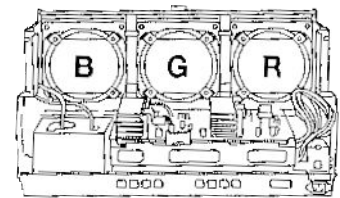

Front side

Back side

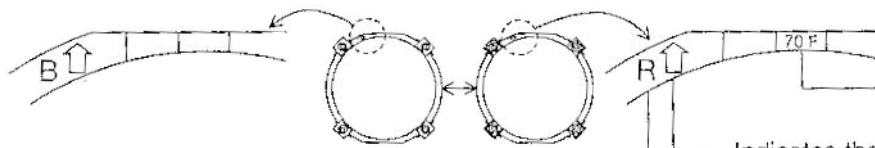

Same as the indications in the above table

Indicates the spacer direction

The R and B spacers are the same.

The letter "B" appears on the reverse side of the R spacer.

- ⑦ Install the lenses in their original positions, and then secure them with the twelve lens mounting screws.

NOTE:

- Make sure the correct lens is installed to the correct CRT. Check the lens color by referring to the color of the label which is attached to the lens. A silver label is attached blue (B) lens.
- Install the lenses so that the focus adjustment screws are facing upward.

- ⑧ Install the front grille, and then tighten it with the six screws.

- ⑨ Install the X-ray cover, and then tighten it with the four screws.

- ⑩ Close the cover.

NOTE:

- After carrying out this adjustment, the convergence will be greatly changed, so it should also be adjusted.

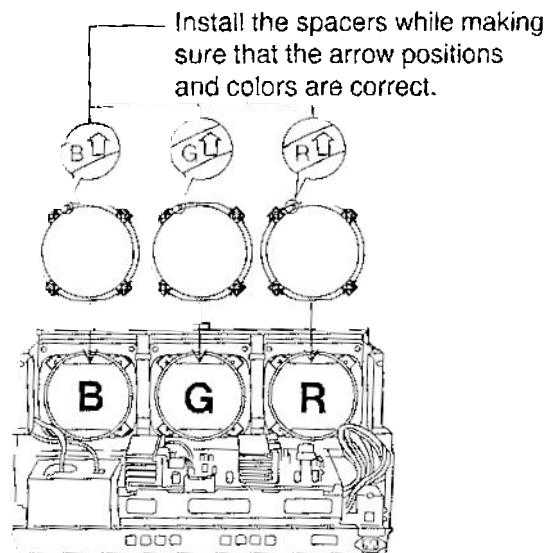

2. Standard setting-up positions

For floor mounting

At the time of shipment from the factory, the projector is set to ceiling-mounting specifications, so you will need to adjust the deflection of the projector.

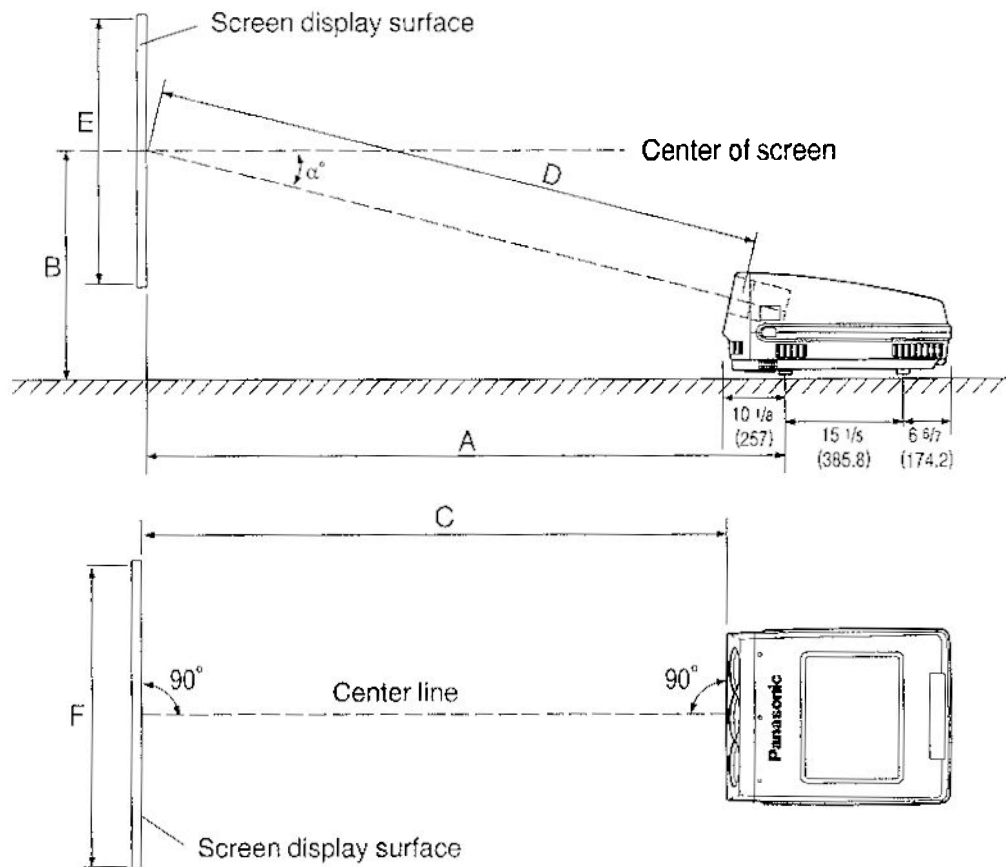

Standard setting-up dimensions

UNIT: inch (mm)

Dimensions Projection size	A Screen surface- Front projector legs	B Center of screen- Floor	C Screen surface- Front of projector	D Center of screen- Edge of G lens	α°	E Height of effective screen area	F Width of effective screen area	CRT angle and lens spacers
60	80 (2,040)	27 (687)	70 (1,783)	73 (1,843)	12.7	36 (914)	48 (1,219)	Change necessary
70	91 (2,307)	29 (748)	81 (2,050)	83 (2,117)	12.7	42 (1,067)	56 (1,422)	
80	101 (2,572)	32 (819)	91 (2,315)	94 (2,390)	13.0	48 (1,219)	64 (1,626)	Change not necessary
100	122 (3,104)	37 (942)	112 (2,847)	116 (2,937)	13.0	60 (1,524)	80 (2,032)	
120	143 (3,638)	42 (1,066)	133 (3,381)	137 (3,484)	13.0	72 (1,829)	96 (2,438)	
150	175 (4,433)	50 (1,273)	164 (4,176)	169 (4,305)	13.3	90 (2,286)	120 (3,048)	Change necessary
180	206 (5,231)	58 (1,462)	196 (4,974)	202 (5,126)	13.3	108 (2,743)	144 (3,658)	
200	227 (5,764)	63 (1,588)	217 (5,507)	223 (5,673)	13.3	120 (3,048)	160 (4,064)	
250	279 (7,094)	78 (1,974)	269 (6,837)	277 (7,041)	13.3	150 (3,810)	200 (5,080)	
300	332 (8,425)	91 (2,300)	322 (8,168)	331 (8,409)	13.3	180 (4,572)	240 (6,096)	

NOTE:

- If placing the projector on top of a table, add the height of the table to dimension B.
- The dimensions for the effective screen area are those for an aspect ratio of 4:3.

For ceiling mounting

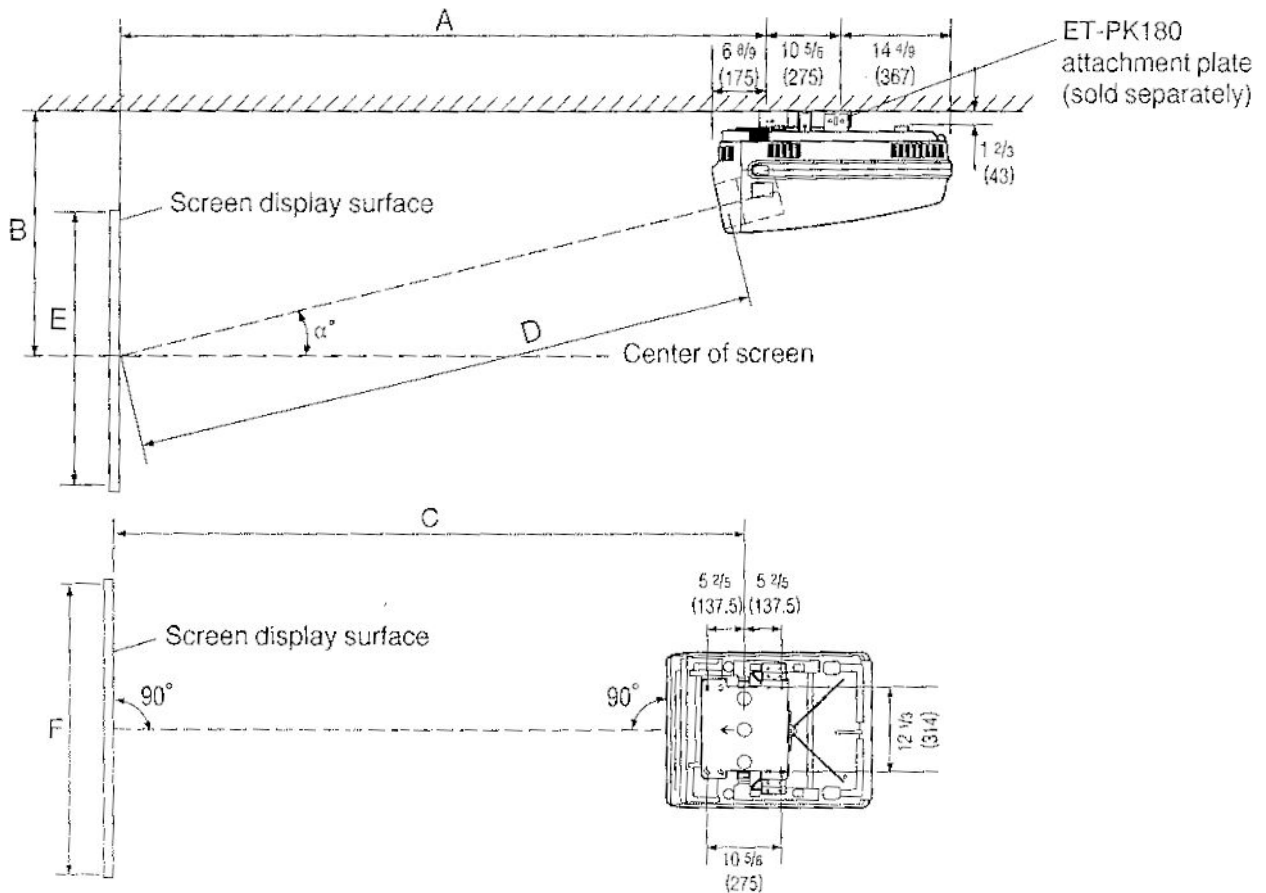

Standard setting-up dimensions

UNIT: inch (mm)

Dimensions Projection size	A	B	C	D	α°	E	F	CRT angle and lens spacers
	Screen surface- Hanging bolt hole	Center of screen- Attachment plate	Screen surface- Attachment plate center	Center of screen- Edge of G lens		Height of effective screen area	Width of effective screen area	
60	77 (1,957)	29 (730)	82 (2,095)	73 (1,843)	12.7	36 (914)	48 (1,219)	Change necessary
70	88 (2,224)	31 (791)	93 (2,362)	83 (2,117)	12.7	42 (1,067)	56 (1,422)	
80	98 (2,489)	34 (862)	103 (2,627)	94 (2,390)	13.0	48 (1,219)	64 (1,626)	Change not necessary
100	119 (3,021)	39 (985)	124 (3,159)	116 (2,937)	13.0	60 (1,524)	80 (2,032)	
120	140 (3,555)	44 (1,109)	145 (3,693)	137 (3,484)	13.0	72 (1,829)	96 (2,438)	Change necessary
150	171 (4,350)	52 (1,316)	177 (4,488)	169 (4,305)	13.3	90 (2,286)	120 (3,048)	
180	203 (5,148)	59 (1,505)	208 (5,286)	202 (5,126)	13.3	108 (2,743)	144 (3,658)	
200	224 (5,681)	64 (1,631)	229 (5,819)	223 (5,673)	13.3	120 (3,048)	160 (4,064)	
250	276 (7,011)	79 (2,017)	281 (7,149)	277 (7,041)	13.3	150 (3,810)	200 (5,080)	
300	328 (8,342)	92 (2,343)	334 (8,480)	331 (8,409)	13.3	180 (4,572)	240 (6,096)	

NOTE:

- If suspending the attachment plate by means of ceiling hanging bolts, add the distance from the ceiling to the attachment plate to dimension B.
- The dimensions for the effective screen area are those for an aspect ratio of 4:3.

For rear mounting

If using the rear mounting method to set up the projector, you will need to change the deflection and replace the spacers. It may also be necessary to change the CRT angle.

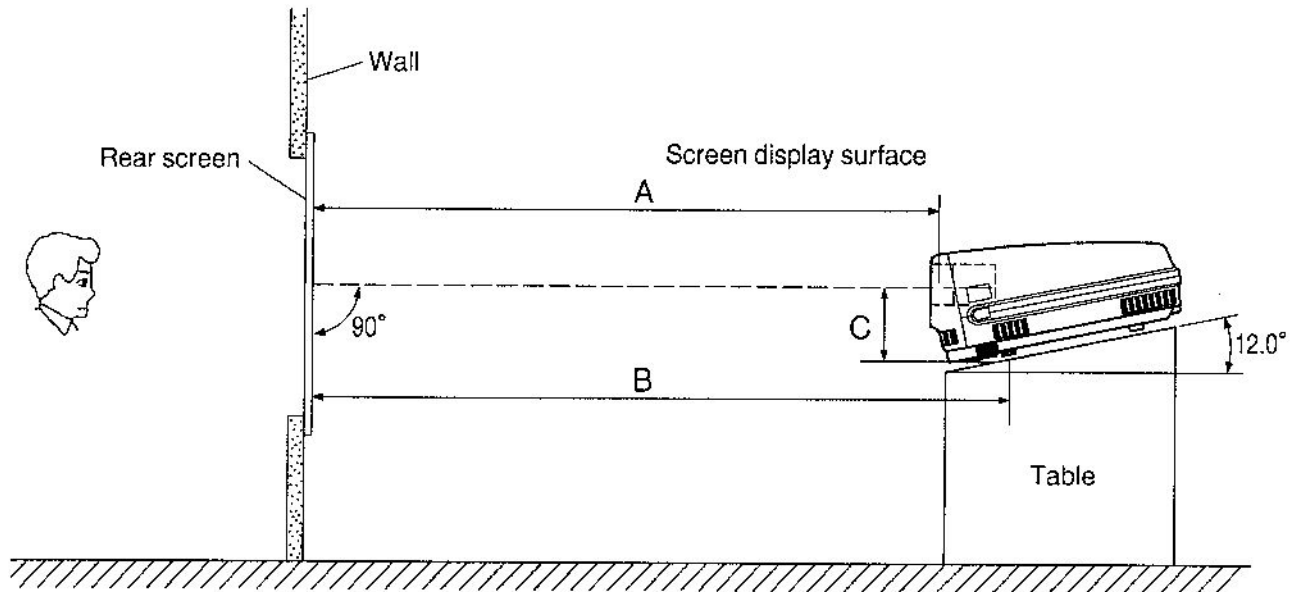

Standard setting-up dimensions

UNIT: inch (mm)

Dimensions	A	B	C			CRT angle
Projection size	Center of screen- Edge of G lens	Screen surface- Front projector legs	Center of screen- Front projector legs	Height of effective screen area	Width of effective screen area	
60	72 (1,831)	84 (2,129)	9 (229)	36 (914)	48 (1,219)	Change necessary
70	83 (2,103)	95 (2,401)	9 (229)	42 (1,067)	56 (1,422)	
80	94 (2,376)	105 (2,673)	9 (229)	48 (1,219)	64 (1,626)	Change not necessary
100	115 (2,919)	127 (3,216)	9 (229)	60 (1,524)	80 (2,032)	
120	136 (3,463)	148 (3,760)	9 (229)	72 (1,829)	96 (2,438)	Change necessary
150	168 (4,279)	180 (4,576)	9 (229)	90 (2,286)	120 (3,048)	
180	201 (5,094)	212 (5,391)	9 (229)	108 (2,743)	144 (3,658)	
200	222 (5,638)	234 (5,935)	9 (229)	120 (3,048)	160 (4,064)	
250	275 (6,997)	287 (7,294)	9 (229)	150 (3,810)	200 (5,080)	
300	329 (8,356)	341 (8,653)	9 (229)	180 (4,572)	240 (6,096)	

NOTE:

- The dimensions for the effective screen area are those for an aspect ratio of 4:3.

3. Changing the deflection

When changing the installation method for the projector from ceiling mounting to floor mounting or rear mounting, you will need to switch over the deflection changeover connectors which are connected to the H printed circuit board and V printed circuit board. These printed circuit boards can be seen when the projector cover is opened. Refer to the illustration below when switching over the connectors.

CAUTION:

- Be sure to turn off the main power supply before switching over the connectors.
- If the connectors are not fully inserted, or if they are inserted in the wrong place, it might cause problems with the operation of the projector.

※V.BIAS control

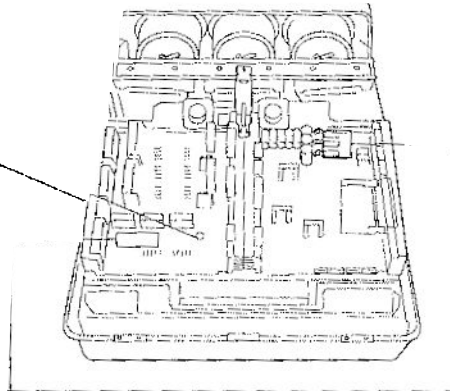

For floor mounting and rear mounting (with a mirror)

Vertical deflection changeover connectors

Insert connectors V04, V05 and V06 into sockets V41, V51 and V61 at the rear respectively.

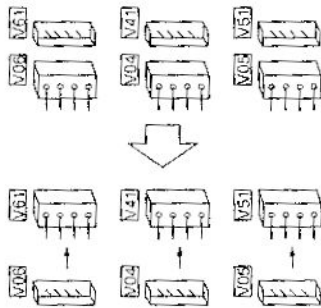

Horizontal deflection changeover connectors

Turn connectors H1, H2 and H3 180° respectively and insert them into sockets H1-1, H2-1 and H3-1 at the left of each connector.

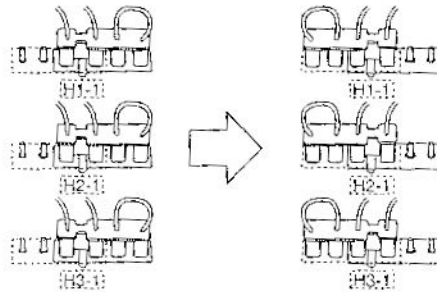

※ Use the V.BIAS control to adjust so that the vertical raster position comes to the middle of the screen.

For rear mounting (without a mirror)

Vertical deflection changeover connectors

Insert connectors V04, V05 and V06 into sockets V41, V51 and V61 at the rear respectively.

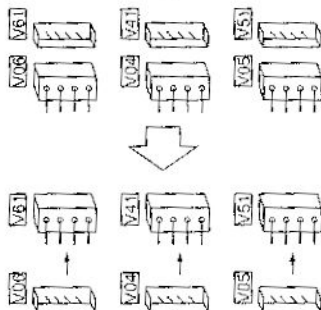

- It is not necessary to switch over the horizontal deflection changeover connectors.

※ Use the V.BIAS control to adjust so that the vertical raster position comes to the middle of the screen.

4. Setting-up and adjustment

Setting-up and adjustment of the projector should only be carried out by qualified service personnel. High voltages are present inside the projector. When adjusting the focus or making other adjustments, be careful not to touch places where current is flowing.

- Read this installation manual and the operation manuals for other components which are being connected before carrying out setting-up and adjustment.

Moreover, the projector's remote control is equipped with the following functions to make adjustment easier.

- (1) A backlighting function makes it easy to see the remote control buttons in the dark.
- (2) The remote control can be hung around your neck by attaching the strap which is supplied as an accessory, so that both hands can be kept free.
- (3) The remote control can be used in both wired and wireless modes.

NOTE:

If the remote control is operated without a full understanding of the functions of each button and of the method of operation, incorrect adjustments may occur, which can result in operation problems. Make sure that you have a thorough understanding of how to use each remote control button before using the remote control.

1. Preparation

1. Turn on the power for all components which have been connected to the projector.
2. Turn on the main power switch at the front of the projector.
3. Press the POWER button on the remote control or on the projector's operation panel to turn on the power.
4. Check that a signal to use for adjustment is being input to the projector.
5. Move the function selection switch inside the battery compartment to the ON position.

2. Checking the picture

1. Check that the picture is being projected correctly onto the screen. If the picture appears upside down or back to front, the deflection changeover connectors have not been connected properly. Re-connect them while referring to "Changing the deflection" on page 76.
2. If the position of the picture on the screen is too far up, down or to the left or right of the screen, or if the sizes of the picture and the screen do not match, the installation position of the screen or projector may be incorrect. Re-check that the distances between the screen and the projector are correct. Furthermore, the problem might be that the CRT angle and the lens spacers do not match.

3. Warming-up

After the picture appears on the screen, leave the projector in that condition for 60 minutes or more to let the performance of the projector stabilize.

4. Checking and adjusting the lens focus

1. Set the control pattern switch on the remote control to the service mode position.
2. Press the TEST button on the remote control so that the crosshatch pattern is displayed on the screen.
3. After pressing the CUT-OFF button, press the R, G and B buttons to switch projection to single colors, and check that the focus for each color is correct.

● If a color is out of focus, open the cover and then carry out the following operation.

- ① Loosen the mounting screws ㉑ of the lens that is out of focus, and then turn the lens until the center of the image on the screen comes into focus. Once the adjustment has been completed, securely tighten mounting screws ㉑.
- ② Loosen the mounting screws ㉒ of the lens that is out of focus, and then turn the lens until the edges of the image on the screen comes into focus. Once the adjustment has been completed, securely tighten mounting screws ㉒.
- ③ If the image is still out of focus even after the adjustments in ① and ② have been made, repeat step ①, and adjust so that the focus for the overall image is at the best setting.

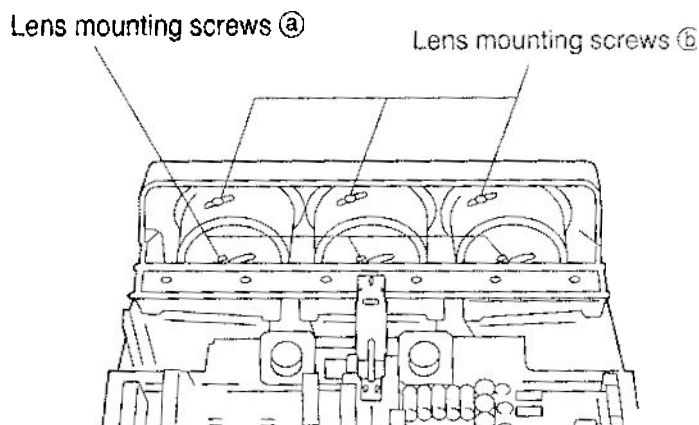

NOTE:

- After focus adjustment has been carried out, the convergence settings will become misaligned, so convergence adjustment should always be carried out as the next step.
- If the focus is still not correct after all adjustments have been carried out, it will be necessary to adjust the static focus. Refer to the following page for procedures for doing this.
- If adjustment is difficult because blooming occurs after the CUT-OFF button and the R, G and B buttons have been pressed to display a single-color image, use the lens caps to cover the lenses that are not being adjusted so that a single-color image is obtained, and carry out adjustment in this condition.

5. Checking and adjusting the static focus

NOTE:

- Adjustment of the static focus should only be carried out if the correct focusing cannot be obtained after normal focus adjustments have been made.
- The remote control does not have a focus button, so static focus adjustment should be carried out using the focus controls inside the projector.

① Loosen the five screws shown in the illustration, and then slide the plate out to remove it. Then remove the four screws shown in the illustration.

② Lift up the printed circuit board.

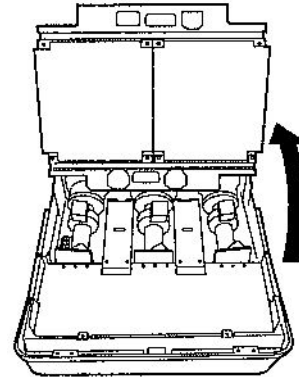
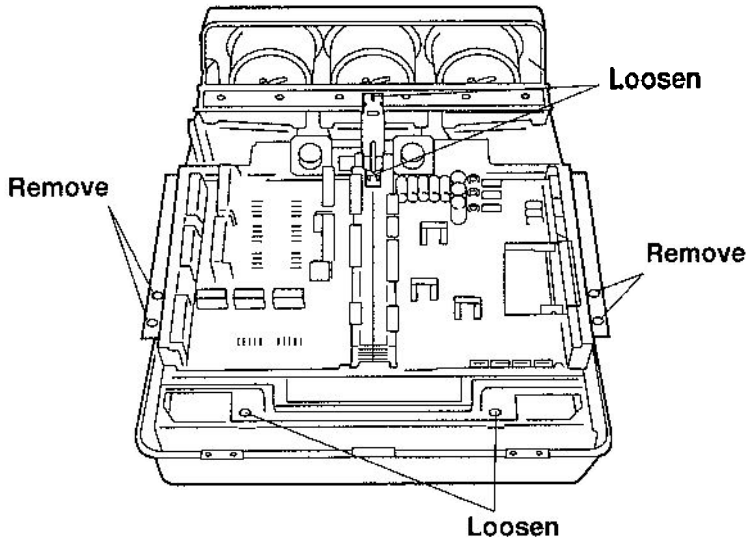

● **Adjusting the static focus**

- ① Press the TEST button on the remote control so that the crosshatch pattern is displayed on the screen.
- ② Cover the lenses which are not being adjusted with the lens caps.
- ③ Turn the focus control inside the focus control block (shown in the illustration at right) which corresponds to the lens being adjusted until the image comes into focus.

<Focus control positions>

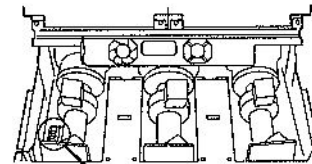

Focus control block

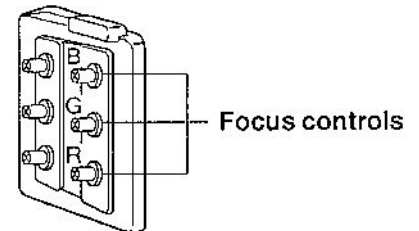

T

6. Checking and adjusting the convergence

Points to note during checking and adjustment

1. If the frequency and synchronizing signals are different for different input signals, convergence adjustment must be carried out for each input signal individually.
2. The projector can store up to a maximum of sixteen different adjustments for RGB signals. In the case of LINE/S-VIDEO signals, it is possible to store different adjustments for NTSC/M-NTSC signals and PAL/SECAM signals. For RGB signals, however, a function is available which lets you copy the contents of a memory. This means that if convergence adjustment is carried out for one signal, signals which are subsequently registered only need to have fine adjustments made to their convergence settings.

NOTE:













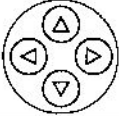

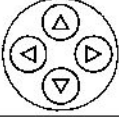

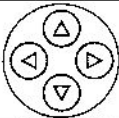

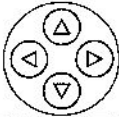

If there is an error in the convergence setting for the first signal registered and this incorrect setting is copied, the error will be duplicated for all signals for which the settings have been copied. Be particularly careful to ensure that the convergence settings for the first signal registered are correct.

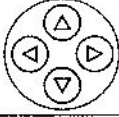
3. To adjust the convergence settings, press the TEST button, and then register the changed setting for each mode by pressing the STORE button twice.
If the STORE button is not pressed twice, any changes made to the convergence settings will not be registered.
4. Carry out the convergence adjustments in the order given below.
 - ① Green dynamic convergence
 - ② Centering convergence
 - ③ Red and blue dynamic convergence
 - ④ Zone convergenceThe zone convergence adjustments should not be used to compensate for incorrect dynamic convergence and centering convergence adjustments, as the resulting adjustments will not give satisfactory results.
5. If the horizontal scanning frequency for the input signals is within the range of 15~29.17 kHz, the right edge of the vertical scanning lines in the crosshatch pattern may become distorted, regardless of the adjustment setting. This occurs because of the nature of the test signal, and does not indicate a problem.

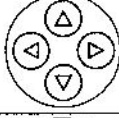
◆ Convergence adjustment procedure

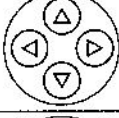
① Adjusting the green dynamic convergence

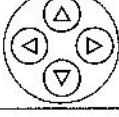
- This adjustment forms the basis for all subsequent convergence adjustments, and so check the whole of the screen when making this adjustment.
- The button operation procedure for adjusting the green dynamic convergence is given below.
(If any adjustments are not necessary, they may be omitted from the adjustment procedure.)









Procedure	Remote control operation	Purpose of operation and adjustment item
1		Set to the crosshatch pattern.
2	 →  →  (Press twice)	Horizontal and vertical skewness adjustment
3	 →  →  (Press twice)	Horizontal and vertical bowing adjustment
4	 →  →  (Press twice)	Horizontal and vertical screen size adjustment
5	 →  →  (Press twice)	Horizontal and vertical linearity adjustment
6	 →  →  →  (Press twice)	Horizontal and vertical keystone adjustment
7	 →  →  (Press twice)	Horizontal and vertical keystone balance adjustment
8	 →  →  (Press twice)	Horizontal and vertical pin cushion distortion adjustment
9	 →  →  (Press twice)	Horizontal and vertical pin cushion balance adjustment

NOTE:

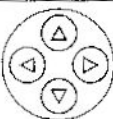
- You can use either of the following two methods to register changed settings in memory by pressing the STORE button.
 - (1) Pressing the STORE button twice after each adjustment mode setting has been completed
 - (2) Pressing the STORE button twice after all adjustments from 1 to 9 have been completed

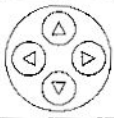
② Adjusting the centering convergence

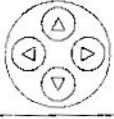
- When adjusting the centering convergence after adjustment of the green dynamic convergence has been completed, use the button operations which are given in the table below.
(If any adjustments are not necessary, they may be omitted from the adjustment procedure.)

Procedure	Remote control operation	Purpose of operation and adjustment item
1		Set to centering adjustment mode.
2	 → 	Adjust the center position of the green picture.
3	 (Press twice)	Press STORE twice to register the change.
4	 (Press once or twice)	if pressed once (R-G): Adjust red (R) to match green (G) if pressed twice (R-G-B): Adjust red (R) to match green (G) and blue (B)
5		Use the arrow buttons to adjust the centering of the red image.
6	 (Press twice)	Press STORE twice to register the change.
7	 (Press once or twice)	If pressed once (B-G): Adjust blue (B) to match green (G) If pressed twice (B-G-R): Adjust blue (B) to match green (G) and red (R)
8		Use the arrow buttons to adjust the centering of the blue image.
9	 (Press twice)	Press STORE twice to register the change.

③ Adjusting the red and blue dynamic convergence

- Carry out these adjustments after green dynamic convergence adjustment and centering convergence adjustment have been completed.
- Use the button operations which are given in the table below to adjust the red and blue dynamic convergence. (If any adjustments are not necessary, they may be omitted from the adjustment procedure.)

(1) Adjusting the red dynamic convergence

Procedure	Remote control operation	Purpose of operation and adjustment item
1	 (Press twice)	Adjust the horizontal and vertical screen size.
※	 (Press once or twice)	If pressed once (R-G): Adjust red (R) to match green (G) If pressed twice (R-G-B): Adjust red (R) to match green (G) and blue (B)
2	 (Press twice)	Adjust the horizontal and vertical linearity.
3	 (Press twice)	Adjust the horizontal and vertical skewness.
4	 (Press twice)	Adjust the horizontal and vertical keystone distortion.
5	 (Press twice)	Adjust the horizontal and vertical bowing.
6	 (Press twice)	Adjust the horizontal and vertical pin cushion distortion.
7	 (Press twice)	Adjust the horizontal and vertical pin cushion balance.

(2) Adjusting the blue dynamic convergence







- The procedure for adjusting the blue dynamic convergence is the same as that for the red dynamic convergence given above. However, in step (1), press the B button to adjust blue (B) to match green (G) (B-G), and to adjust blue (B) to match green (G) and red (R) (B-G-R).

NOTE:

- You can use either of the following two methods to register changed settings in memory by pressing the STORE button.
 - (1) Pressing the STORE button twice after each adjustment mode setting has been completed
 - (2) Pressing the STORE button twice after all adjustments from 1 to 7 have been completed

④ Adjusting the zone convergence

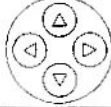
- This adjustment should be carried out if localized color misalignments occur which cannot be corrected by means of dynamic convergence adjustment or centering adjustment.
- Use the button operations which are given in the table below to adjust the zone convergence.

Procedure	Remote control operation	Purpose of operation and adjustment item
1		Set to zone convergence adjustment mode
2	 (Press once or twice)	If pressed once (R-G): Adjust red (R) to match green (G) If pressed twice (R-G-B): Adjust red (R) to match green (G) and blue (B)
* The cursor is displayed on the screen over the top of the characters displayed. If the cursor is difficult to see, carry out the following procedure.		
3		Turn off the on-screen display of characters.
4		Move the cursor to the zone to be adjusted.
5		Adjust the red zone convergence.
6	Repeat steps 4 and 5.	Adjust the red misalignment for other zones (1~21) as required.
7	 (Press once or twice)	If pressed once (B-G): Adjust blue (B) to match green (G) If pressed twice (B-G-R): Adjust blue (B) to match green (G) and red (R)
8	Repeat steps 4 and 5.	Adjust the blue misalignment for other zones (1~21) as required.
9	 (Press twice)	Press STORE twice to register the change.

NOTE:

After setting-up and adjustment has been completed, carry out the following steps before returning the remote control to the customer.

- (1) Move the control pattern switch of the remote control to the normal position.
- (2) Move the function selection switch inside the battery compartment to the OFF position.

Once these steps have been carried out, the remote control cannot be used to change the setting-up adjustments. If they are not done, the customer might accidentally alter the adjustment settings.

7. Checking and adjusting the raster

Points to note during checking and adjustment

1. Check the position, raster size, linearity and display area of the picture being projected onto the screen. If there is any misalignment, adjust by the procedures given below.
2. If large-scale adjustments are necessary, it might be that the projection distance is incorrect or that the screen setting-up position is incorrect. Check the relative positions of the projector and the screen before carrying out adjustment.

● Adjusting the picture center position

- ① Press the RGB POSITION button.
The V and H adjustment settings will be displayed on the screen.
- ② Use the arrow buttons to adjust the picture center position (vertically and horizontally).

● Adjusting the horizontal and vertical amplitude

- ① Press the RASTER SIZE button.
The V and H adjustment settings will be displayed on the screen.
- ② Use the arrow buttons to adjust the horizontal and vertical amplitude of the picture.

● Adjusting the horizontal and vertical linearity

- ① Press the RASTER LIN button.
The V and H adjustment settings will be displayed on the screen.
- ② Use the arrow buttons to adjust the horizontal and vertical linearity of the picture.

● Adjusting the horizontal and vertical blanking

- ① Press the BLK button.
The V and H adjustment settings will be displayed on the screen.
- ② Use the arrow buttons to adjust the horizontal and vertical blanking of the picture.

REMOTE CONTROL OPERATION (Service mode) PROCEDURE

NOTE:

- Carry out the following before switching the remote control unit to service mode.
 1. Move the CONTROL PATTERN switch to the SERVICE position.
 2. Move the service mode ON/OFF switch inside the battery compartment to the ON position.
- All screen explanations which are subsequently given here assume that the ON SCREEN button on the remote control has been pressed so that messages appear on the screen.

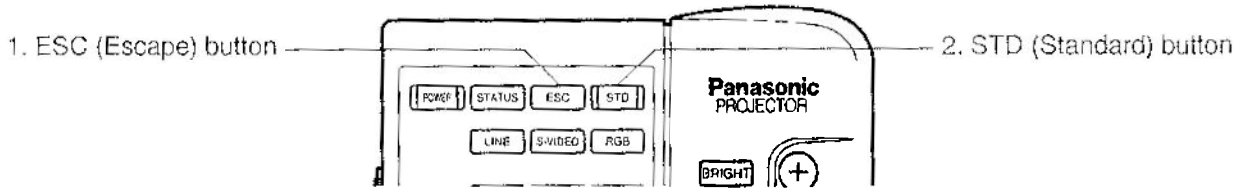

1. ESC (Escape) button



This button is used to cancel adjustment mode and to cancel an operation made in adjustment mode.

- When this button is pressed, adjustment mode is canceled and the display returns to the normal screen.
- The STD (Standard) button and STORE button need to be pressed twice to become effective. If the ESC button is pressed after the other two buttons have been pressed only once, the operation is canceled.

2. STD (Standard) button

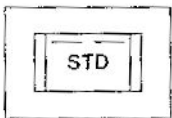

This button is used to reset the setting values for all adjustment contents to the factory default values or to the values which had been previously recorded.

- When in raster adjustment mode, the setting returns to the value which was set previously when this button is pressed once.
(Raster adjustment mode: RGB POSITION, RASTER SIZE, RASTER LIN, BLK)
- When in test pattern adjustment mode, the setting returns to the value which was set previously when this button is pressed twice.
(Test pattern adjustment mode: SIZE, LINER, SKEW, KEYSTONE, BOW, PIN, ZONE, KEYSTONE BALANCE, PIN BALANCE, CENTERING, WB-HIGH, WB-LOW, CLAMP POSITION)

<Raster adjustment mode>

Example: To return the picture size adjustment setting to the previously-recorded setting

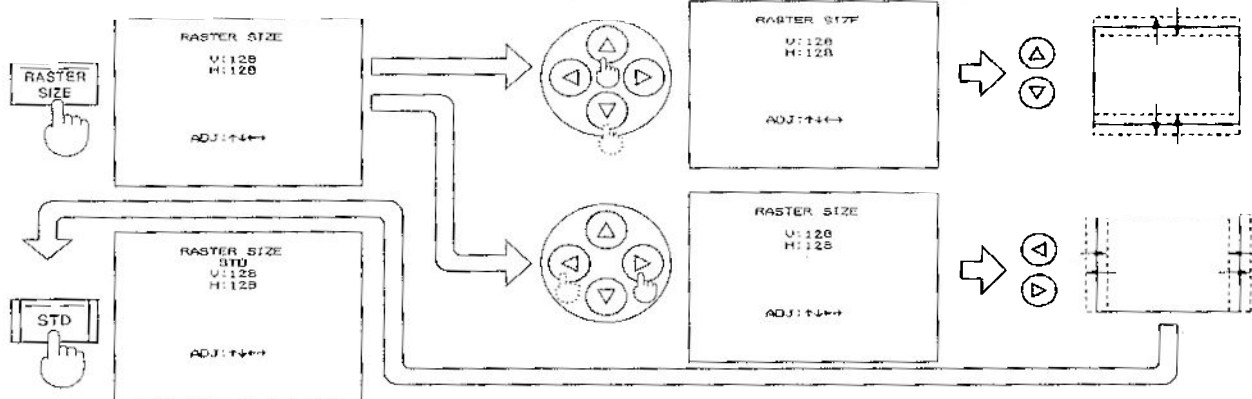

NOTE:

- If the STD (Standard) button is pressed once while in raster adjustment mode, the setting will return to the previously-recorded setting.

<Test pattern adjustment mode>

Example: To return the picture size adjustment setting to the previously-recorded setting

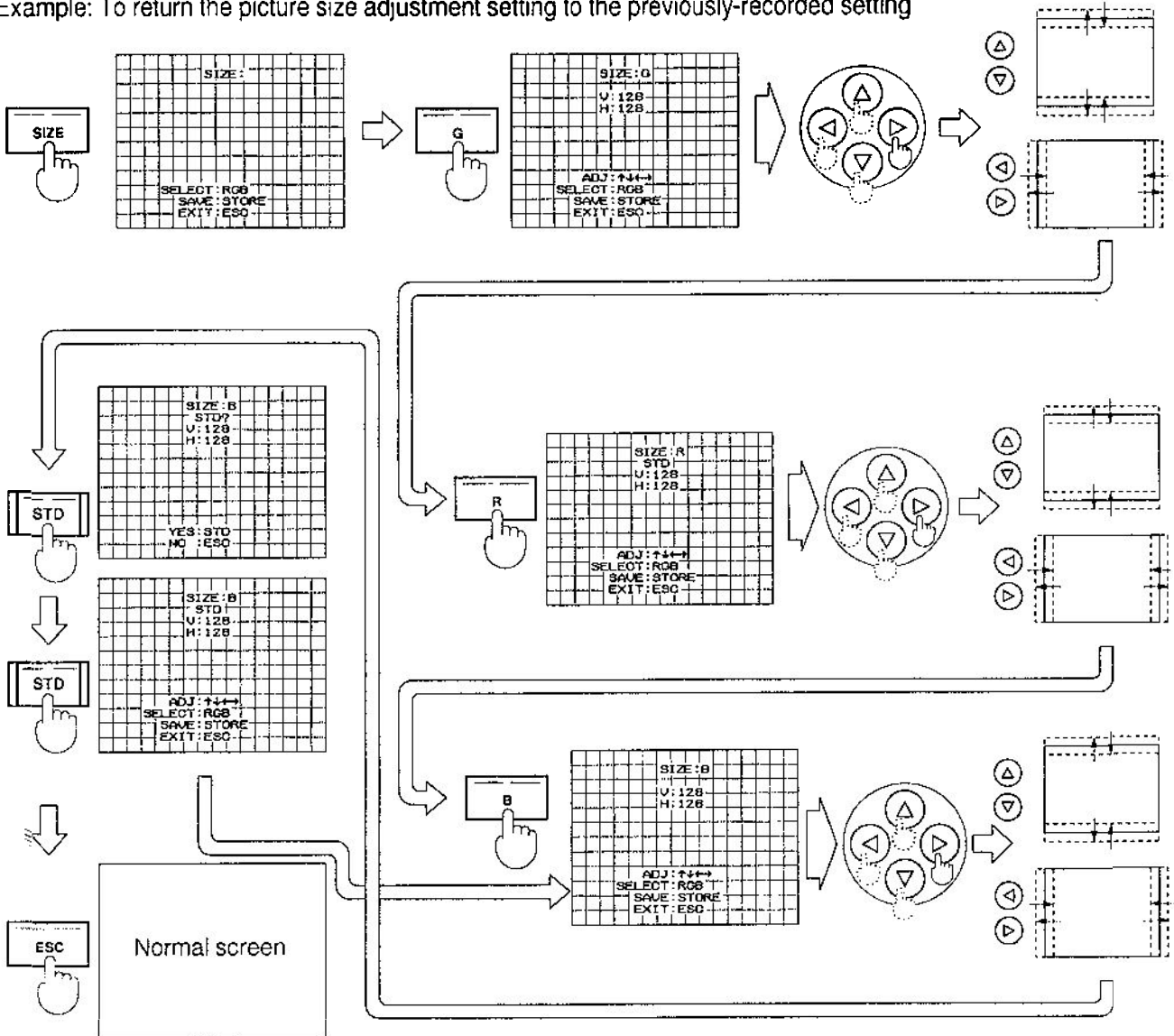

NOTE:

- If the STD (Standard) button is pressed twice while in test pattern adjustment mode, the setting will return to the previously-recorded setting.

3. RGB POSITION button

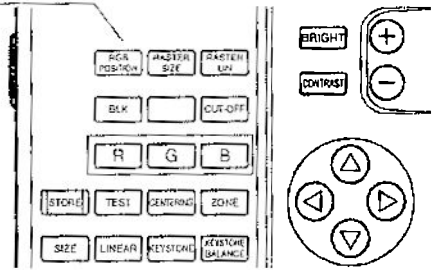

3. RGB POSITION button

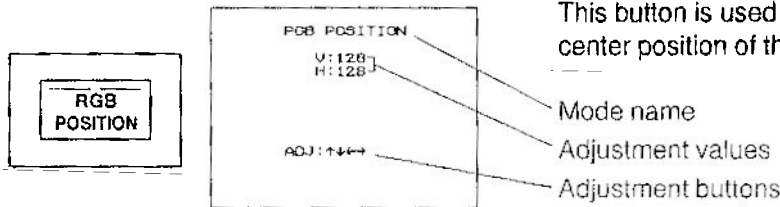

This button is used to switch to the mode for adjusting the center position of the picture image.

NOTE:

- After pressing this button to switch to adjustment mode, the setting values can be adjusted by pressing the arrow buttons.

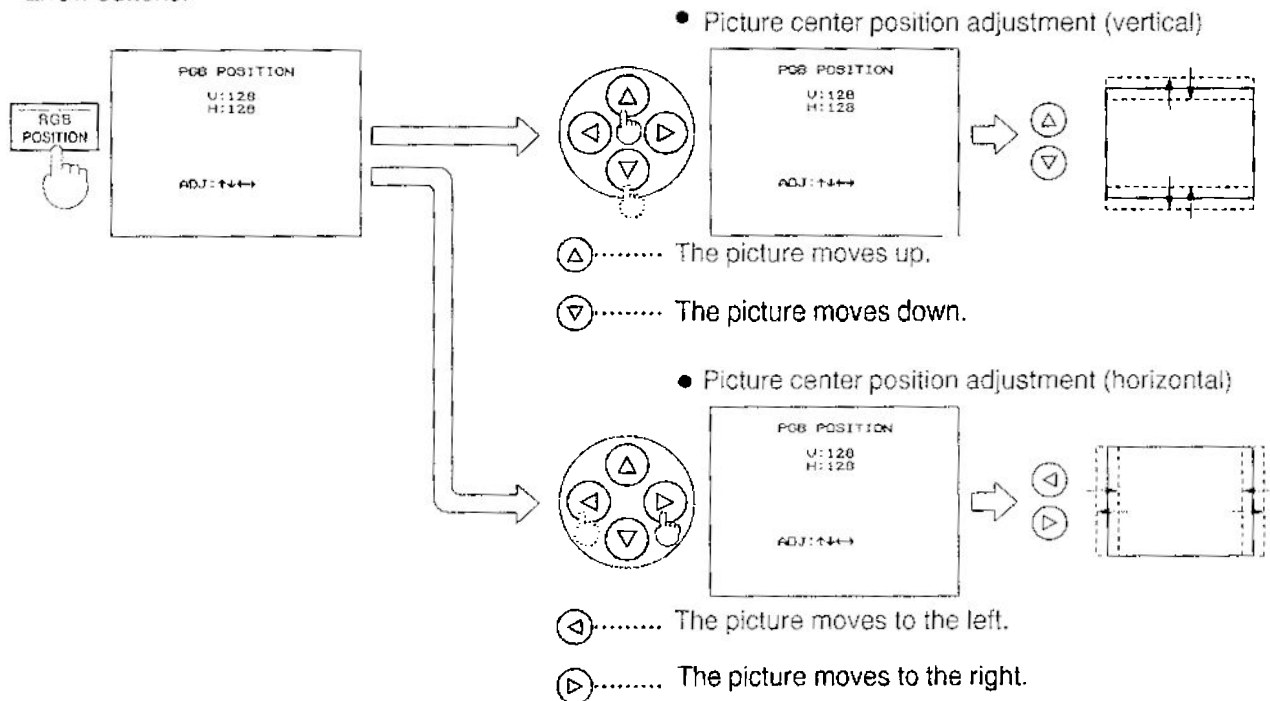

NOTE:

- When adjusting the vertical position of the picture center, if the setting values displayed on the screen change but the picture position does not change, set V-SHIFT in the function menu to ON.
- The setting can be changed within a range of 0~255. The minimum setting value is displayed as MIN and the maximum setting value is displayed as MAX.
- The characters displayed on the screen will be cleared approximately 10 seconds after the button is released.
- When receiving video signals from the LINE IN or S-VIDEO IN terminals, the horizontal position can be adjusted, but the vertical position cannot be adjusted. The vertical adjustment setting will not appear on the screen at this time either.

CAUTION:

- Adjust the raster size in accordance with the display ranges for the video signals being received.

4. RASTER SIZE button

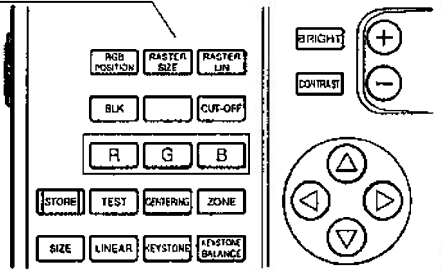

4. RASTER SIZE button

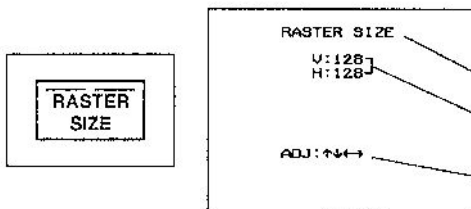

This button is used to switch to the mode for adjusting the height and width of the picture image.

- Mode name
- Adjustment values
- Adjustment buttons

NOTE:

- After pressing this button to switch to adjustment mode, the setting values can be adjusted by pressing the arrow buttons.
- The screen display will toggle between the crosshatch pattern and the crosshair pattern each time the TEST button is pressed. However, make this adjustment using an external input signal.

● Vertical amplitude adjustment

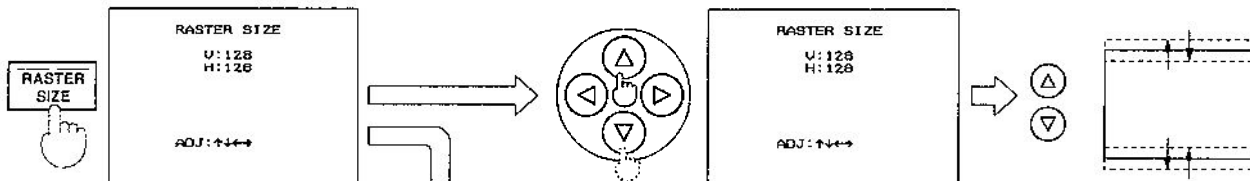

- ▲ The vertical amplitude becomes wider.
- ▼ The vertical amplitude becomes narrower.

● Horizontal amplitude adjustment

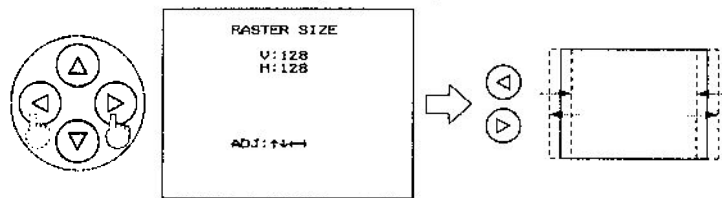

- ◀ The horizontal amplitude becomes narrower.
- ▶ The horizontal amplitude becomes wider.

NOTE:

- The setting can be changed within a range of 0~255. The minimum setting value is displayed as MIN and the maximum setting value is displayed as MAX.
- The characters displayed on the screen will be cleared approximately 10 seconds after the button is released.
- If the horizontal scanning frequency for the input signals is within the range of 15~29.17 kHz, the right edge of the vertical scanning lines in the crosshatch pattern may become distorted, regardless of the adjustment setting. This occurs because of the nature of the test signal, and does not indicate a problem.

5. RASTER LIN button

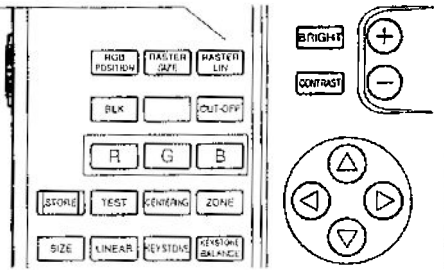

5. RASTER LIN

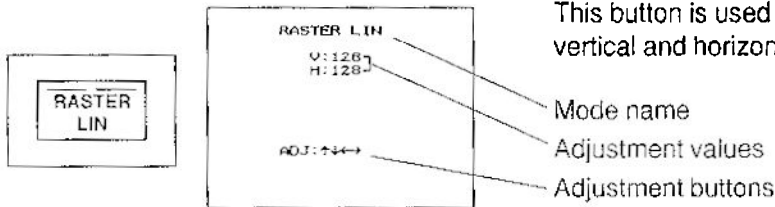

This button is used to switch to the mode for adjusting the vertical and horizontal linearity of the picture image.

NOTE:

- After pressing this button to switch to adjustment mode, the setting values can be adjusted by pressing the arrow buttons.
- The screen display will toggle between the current screen and the crosshatch pattern each time the TEST button is pressed. This adjustment should basically be carried out after pressing the TEST button to switch to the crosshatch pattern.

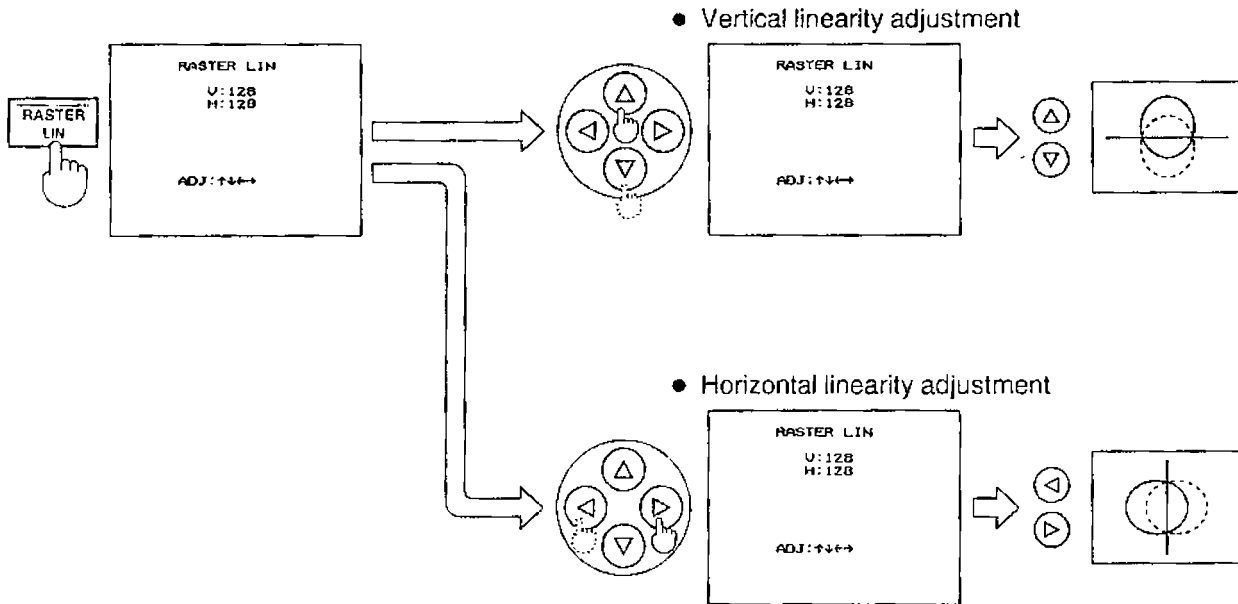

NOTE:

- The setting can be changed within a range of 0~255. The minimum setting value is displayed as MIN and the maximum setting value is displayed as MAX.
- The characters displayed on the screen will be cleared approximately 10 seconds after the button is released.
- If the horizontal scanning frequency for the input signals is within the range of 15~29.17 kHz, the right edge of the vertical scanning lines in the crosshatch pattern may become distorted, regardless of the adjustment setting. This occurs because of the nature of the test signal, and does not indicate a problem.

6. BLK (Blanking) button

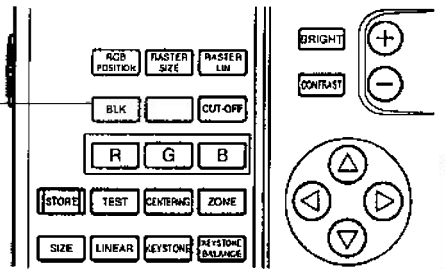

6. BLK (Blanking) button

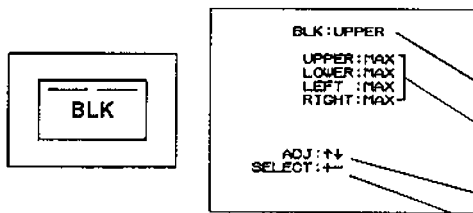

This button is used to switch to the mode for cropping unnecessary parts from the upper, lower, left and right edges of the picture image.

Mode name

Adjustment values

Adjustment buttons

Adjustment mode selection buttons

NOTE:

- After pressing this button to switch to adjustment mode, the setting values can be adjusted by pressing the arrow buttons.

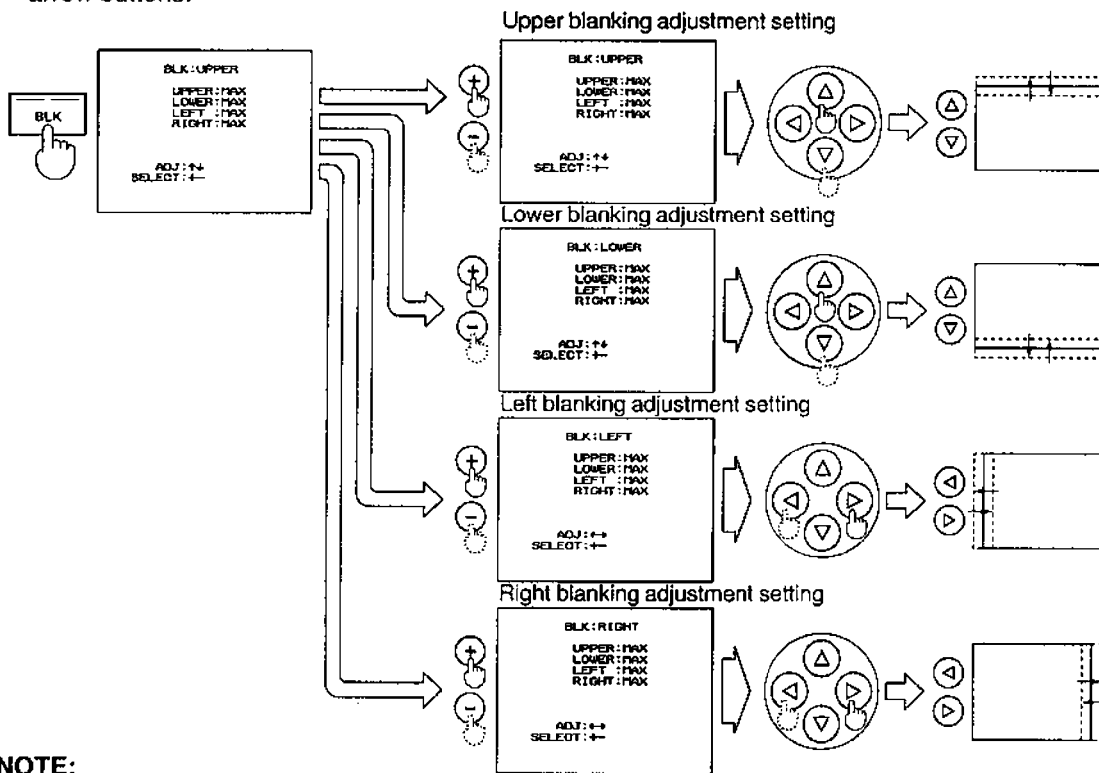

NOTE:

- The setting can be changed within a range of 0~255. The minimum setting value is displayed as MIN and the maximum setting value is displayed as MAX.
- The characters displayed on the screen will be cleared approximately 10 seconds after the button is released. When receiving video signals from the LINE IN or S-VIDEO IN terminals, an incorrect signal will appear if the value is adjusted too high. Adjust the setting to a lower value than the value set at the factory.

7. CUT-OFF button

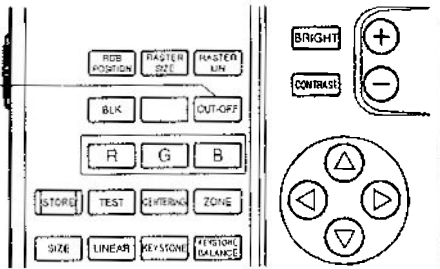

7. CUT-OFF button

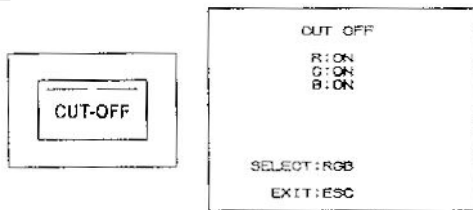

This button is used to switch to cut-off mode. In this mode, the light from each picture tube can be turned on and off individually.

- When this button is pressed, the mode switches to cut-off mode and the characters shown at left appear on the screen. Each time the R, G or B button is then pressed, the corresponding picture tube is turned on or off. To clear cut-off mode, press the ESC (Escape) button.

NOTE.

- Because the lens focus is adjusted when in cut-off mode, this mode can be used to project a single color.

To switch to a green-only picture

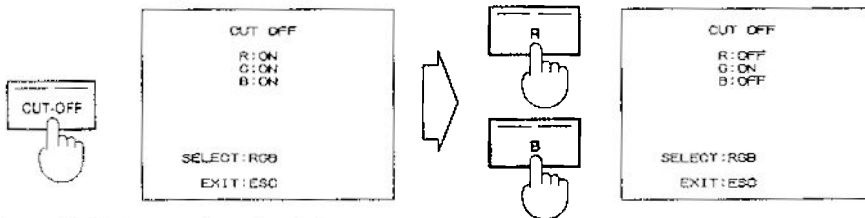

To switch to a red-only picture

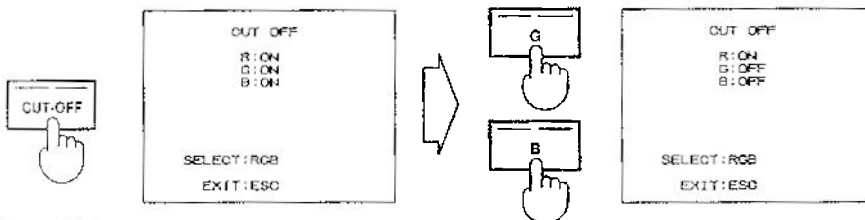

To switch to a blue-only picture

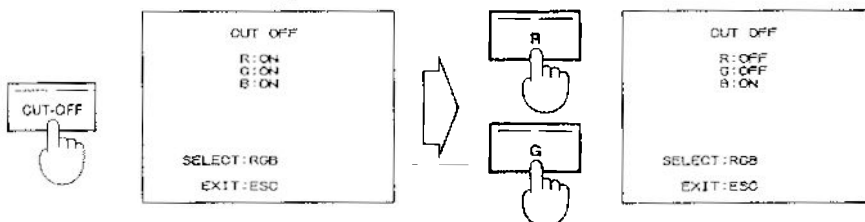

NOTE:

- Once adjustment has been completed, press the ESC (Escape) button to return to the normal screen.

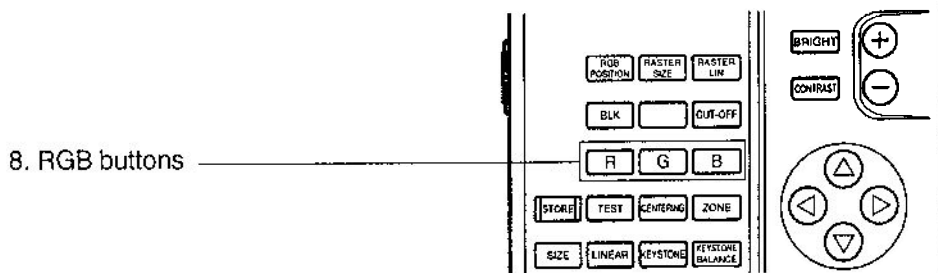

8. RGB buttons

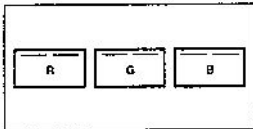

These buttons are used to specify the colors to be adjusted in each adjustment mode.

- If these buttons are pressed in convergence adjustment mode, the adjustment color is specified as explained below.

Each time the R button is pressed, the color of the crosshatch pattern changes and the mode switches between the following two red adjustment modes.

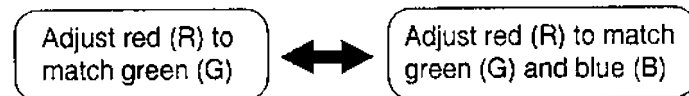

When the G button is pressed, the color of the crosshatch pattern changes to green and the mode switches to green adjustment mode.

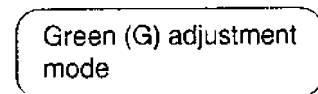

Each time the B button is pressed, the color of the crosshatch pattern changes and the mode switches between the following two blue adjustment modes.

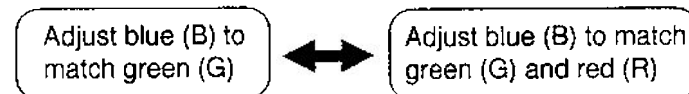

- In white balance adjustment mode, the color to be adjusted is specified when the R, G and B buttons are pressed.
- In cut-off mode, the light for the corresponding picture tube is turned on or off when the R, G and B buttons are pressed.

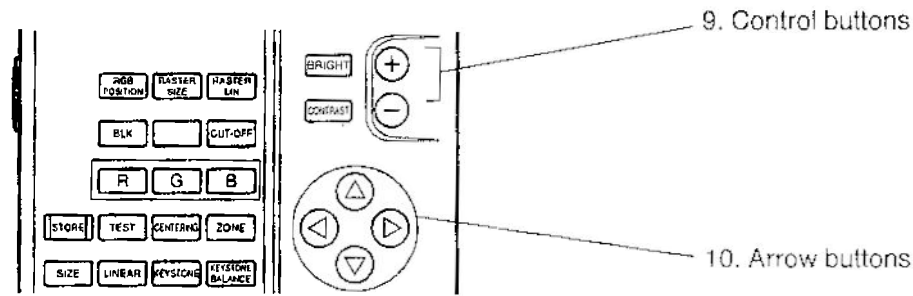

9. Control buttons

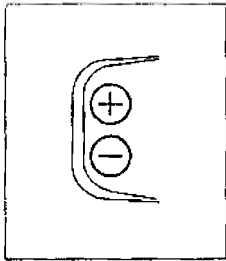

These buttons are used to select the adjustment mode and to set the adjustment levels in each adjustment mode.

- If these buttons are pressed during blanking adjustment, the adjustment mode selection function is activated.
- If these buttons are pressed during zone convergence adjustment, the cursor is moved around on the screen. (Zones 1~21)
- If these buttons are pressed in a picture adjustment mode, level adjustment can be carried out. (BRIGHT, CONTRAST, COLOR, TINT, SHARPNESS)

10. Arrow buttons

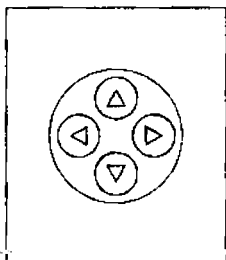



These buttons are used to adjust the setting levels in each adjustment mode.

- These buttons can be operated when characters are being displayed on the screen in an adjustment mode.
- The settings can be changed within a range of 0~255. The minimum setting value is displayed as MIN and the maximum setting value is displayed as MAX. (MIN, 1, 2, 3...253, 254, MAX)
- After the adjustment mode has been selected, pressing these buttons has the following effect.

When the  button is pressed, the item is adjusted upward.

When the  button is pressed, the item is adjusted downward.











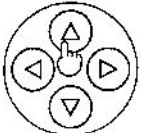
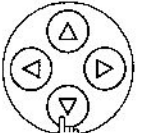
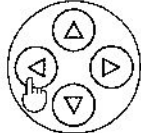
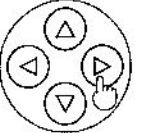
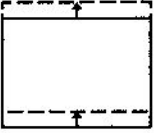



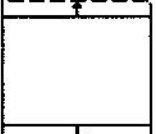
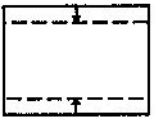
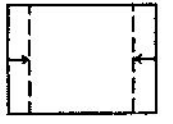

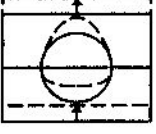
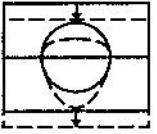
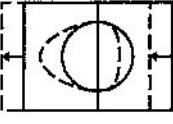
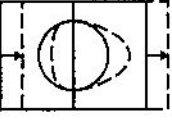
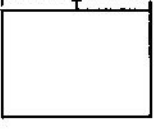
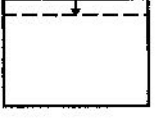



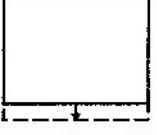

When the  button is pressed, the item is adjusted to the right.





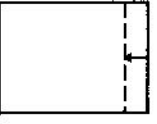

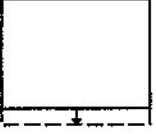
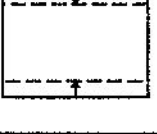



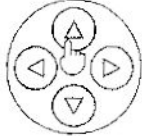
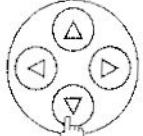
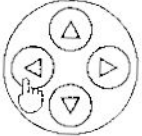
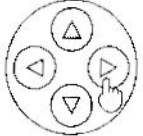
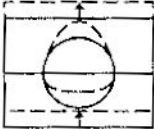

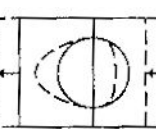
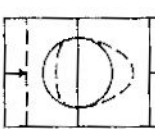

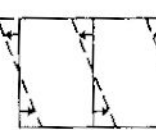















When the  button is pressed, the item is adjusted to the left.

NOTE:

- In raster adjustment mode, the characters displayed on the screen will be cleared approximately 10 seconds after the button is released, and the adjustment mode will be cleared.
- The convergence changes for each arrow button are different for each convergence mode. Refer to the following pages for details.

Change convergence for each arrow button

<div style="text-align: right;">Arrow button</div> <div style="text-align: left;">Convergence mode</div>				
RGB POSITION				
RASTER SIZE				
RASTER LIN				
BLK UPPER				
BLK LOWER				
BLK LEFT				
BLK RIGHT				
SIZE				

<div style="text-align: right; padding-right: 5px;">Arrow button</div> <div style="text-align: left; padding-left: 5px;">Convergence mode</div>				
LINEAR				
SKEW				
KEYSTONE				
KEYSTONE BALANCE				
BOW				
PIN				
PIN BALANCE				
CENTERING				

11. STORE button

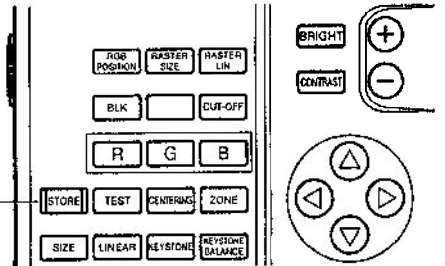

11. STORE button



After convergence, white balance and clamp position settings have been changed, this button is used to register the changed settings.

Changes in settings are registered when this button is pressed twice.

- Convergence settings can be registered in each adjustment mode, but the changed setting is only registered after all other settings have been completed.

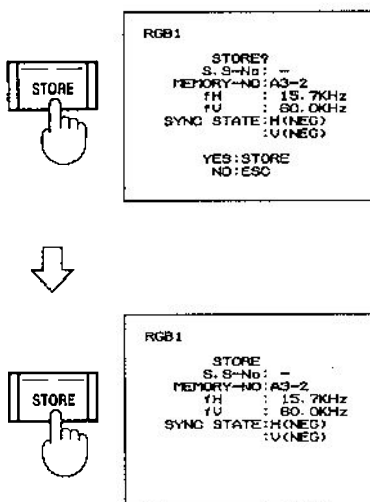

- When the STORE button is pressed once, the contents for the signal which is currently being input are displayed, along with the prompt "STORE?" in yellow letters.
- If the STORE button is then pressed once more, the yellow "STORE?" prompt changes to a red "STORE", and then after 1~2 seconds, "STORE COMPLETE!" is displayed in red to indicate that the adjusted settings have been registered.
- After the STORE button has been pressed once, if you would like to cancel the changes made to the settings, press the ESC (Escape) button. The adjustment mode will then be cleared and the changed settings will not be registered.
- If you would like to clear the adjustment settings, turn off the power for the projector without pressing the STORE button, or switch the input signal to a source with a different frequency and synchronizing signal.
- The adjusted settings cannot be cleared once the STORE button has been pressed twice.

NOTE:

- If the input signal source is switched or the power is turned off after convergence adjustment without pressing the STORE button, the adjusted settings will be cleared.
- If the main power supply for the projector is turned off between the time when the yellow "STORE?" prompt is displayed and the red "STORE COMPLETE!" message appears, the adjustment data may be lost.

12. TEST button

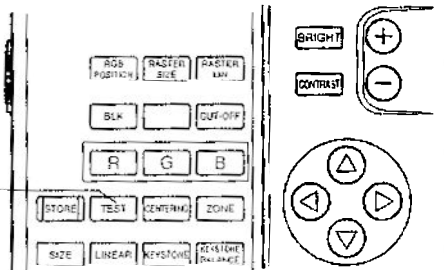

12. TEST button



This button causes each of the seven test patterns to be displayed.

- Each time this button is pressed, the test pattern display switches to one of the seven test patterns, including the crosshatch pattern.
- The buttons used to adjust the convergence cannot be operated unless the TEST button is first pressed to display a test pattern.

Types of test pattern and order of appearance

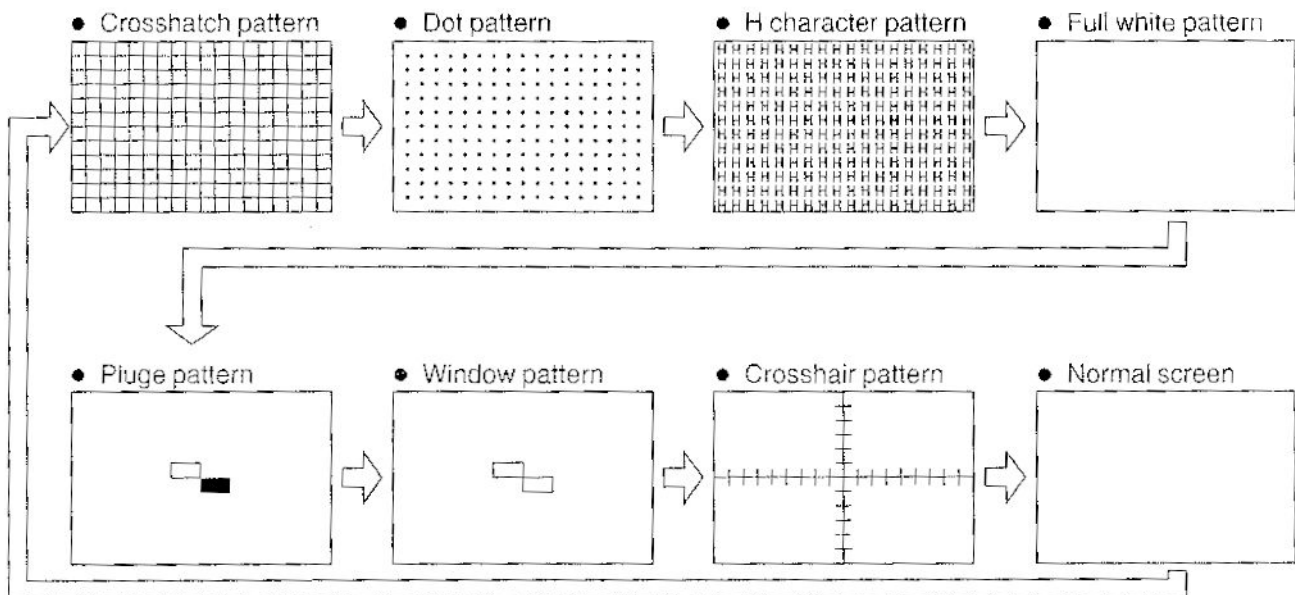

NOTE:

- The H character pattern and crosshair pattern will not be displayed if the on-screen character display function has been turned off.
- If the horizontal scanning frequency for the input signals is within the range of 15~29.17 kHz, the right edge of the vertical scanning lines in the crosshatch pattern may become distorted, regardless of the adjustment setting. This occurs because of the nature of the test signal, and does not indicate a problem.
- The display can be returned to the normal screen by pressing the ESC (Escape) button.
- Only the crosshatch pattern and crosshair pattern can be displayed when in raster size adjustment mode.

13. SIZE button

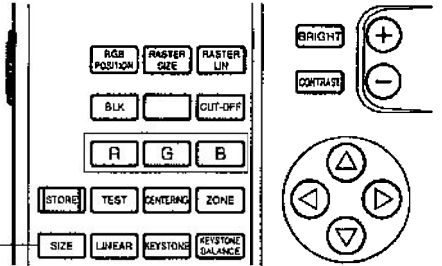

13. SIZE button



This button is used to switch to dynamic convergence adjustment mode for adjusting the picture sizes for the red (R), green (G) and blue (B) pictures respectively.

- Setting is possible once the TEST button has been pressed so that a test pattern is displayed on the screen.
- When adjusting the green (G) size, all three colors will be adjusted at the same time.
- You can adjust the convergence or white balance (page 78~93) while displaying either the internally-generated test signal or an externally-generated test signal by pressing the TEST key when in an adjustment mode.

Button operation procedure

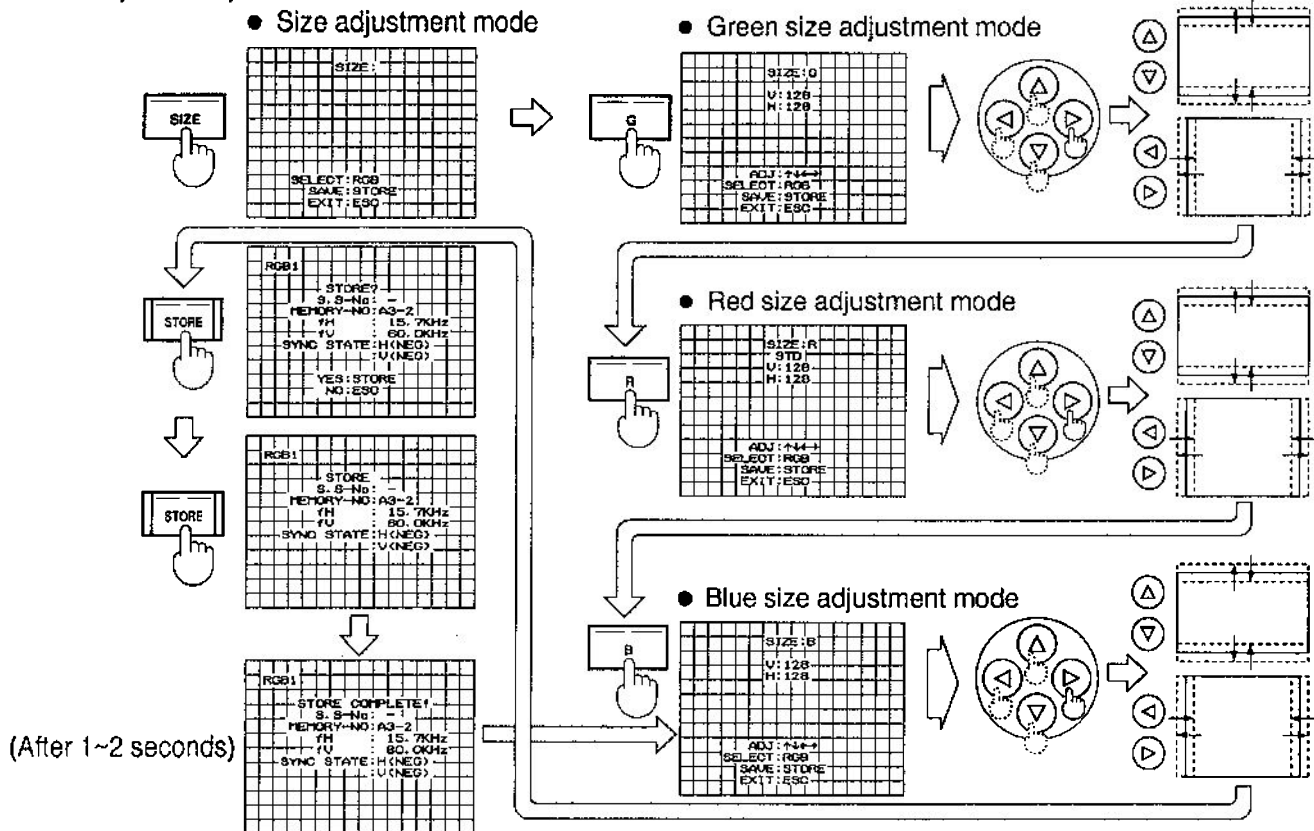

NOTE:

- In addition to using the above method, the color sizes can also be saved by pressing the STORE button twice to store the changes after each color has been adjusted.
- If you would like to clear the adjustment settings, turn off the power for the projector without pressing the STORE button. The adjusted settings cannot be cleared once the STORE button has been pressed twice.

14. LINEAR button

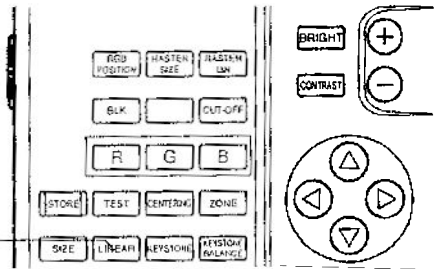

14. LINEAR button

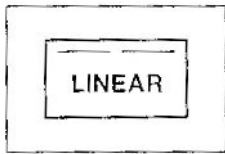

This button is used to switch to dynamic convergence adjustment mode for adjusting the linearity (elongation and compression) of the red (R), green (G) and blue (B) picture segments.

- Setting is possible once the TEST button has been pressed so that a test pattern is displayed on the screen.
- When adjusting the green (G) linearity, all three colors will be adjusted at the same time.

Button operation procedure

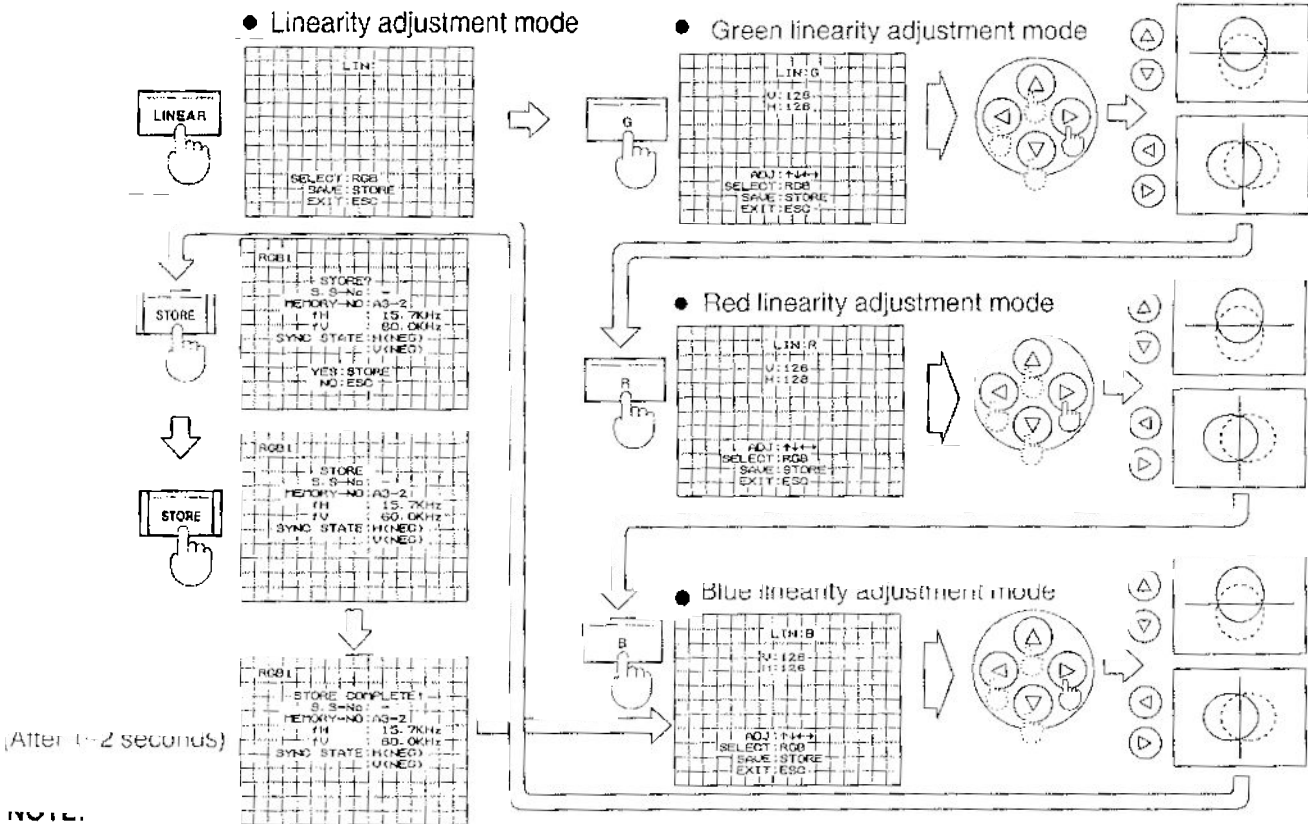

NOTE:

- In addition to using the above method, the linearity settings can also be saved by pressing the STORE button twice to store the changes after each color has been adjusted.
- If you would like to clear the adjustment settings, turn off the power for the projector without pressing the STORE button. The adjusted settings cannot be cleared once the STORE button has been pressed twice.

15. SKEW button

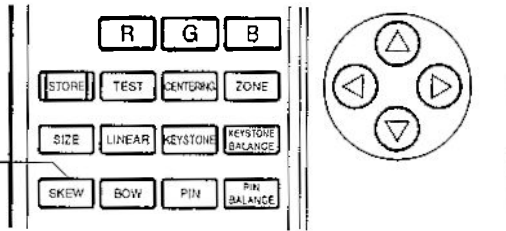

15. SKEW button

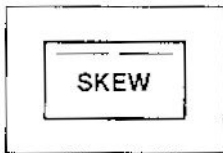

This button is used to switch to dynamic convergence adjustment mode for adjusting the skewness of the red (R), green (G) and blue (B) picture segments.

- Setting is possible once the TEST button has been pressed so that a test pattern is displayed on the screen.

Button operation procedure

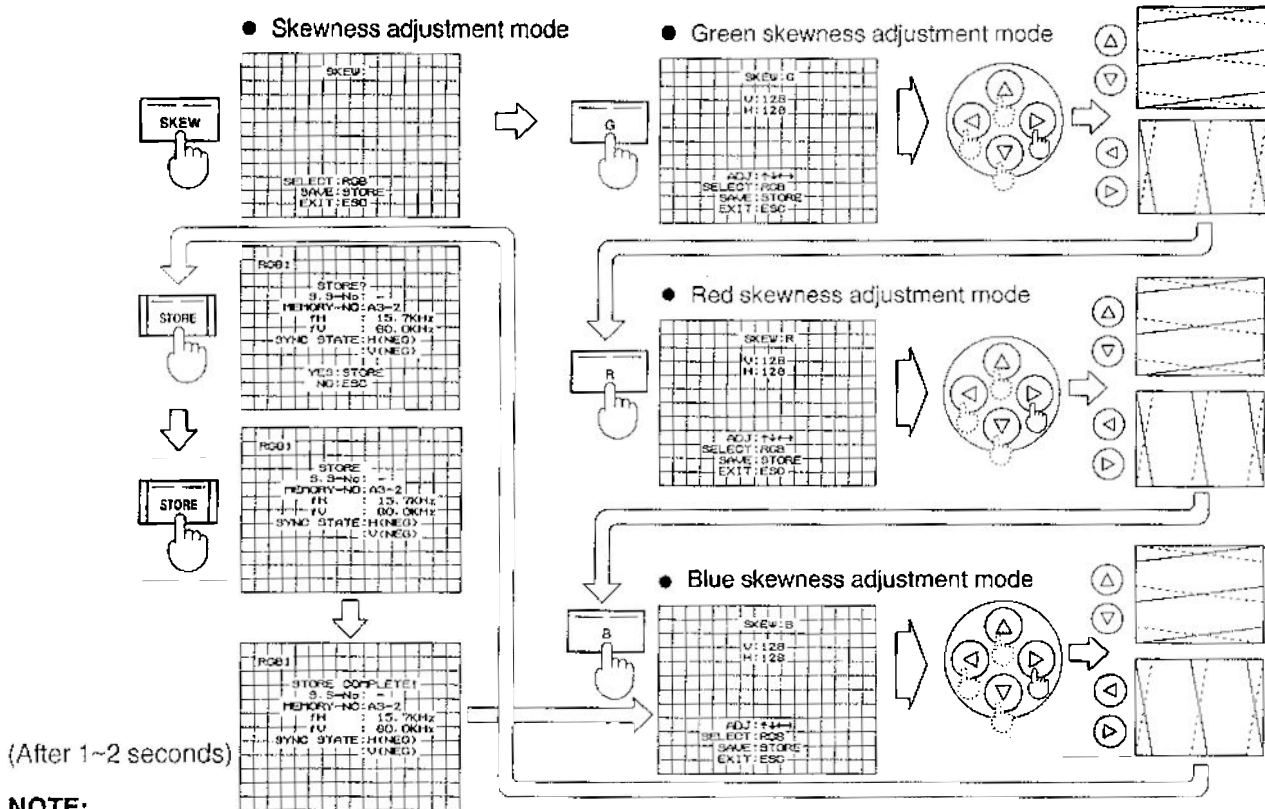

NOTE:

- In addition to using the above method, the skewness settings can also be saved by pressing the STORE button twice to store the changes after each color has been adjusted.
- If you would like to clear the adjustment settings, turn off the power for the projector without pressing the STORE button. The adjusted settings cannot be cleared once the STORE button has been pressed twice.
- The vertical adjustment value can be set to a value from 98 to 158. If the distortion cannot be corrected by setting within this range, the projector is probably tilted at the wrong angle. Place the projector so that it is sitting horizontally.

16. KEYSTONE button

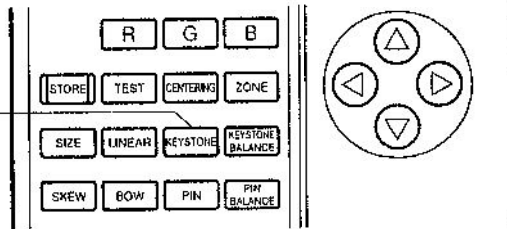

16. KEYSTONE button

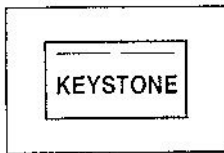

This button is used to switch to dynamic convergence adjustment mode for adjusting the keystone (orthogonality) of the red (R), green (G) and blue (B) picture segments.

- Setting is possible once the TEST button has been pressed so that a test pattern is displayed on the screen.
- When adjusting the green (G) keystone, all three colors will be adjusted at the same time.

Button operation procedure

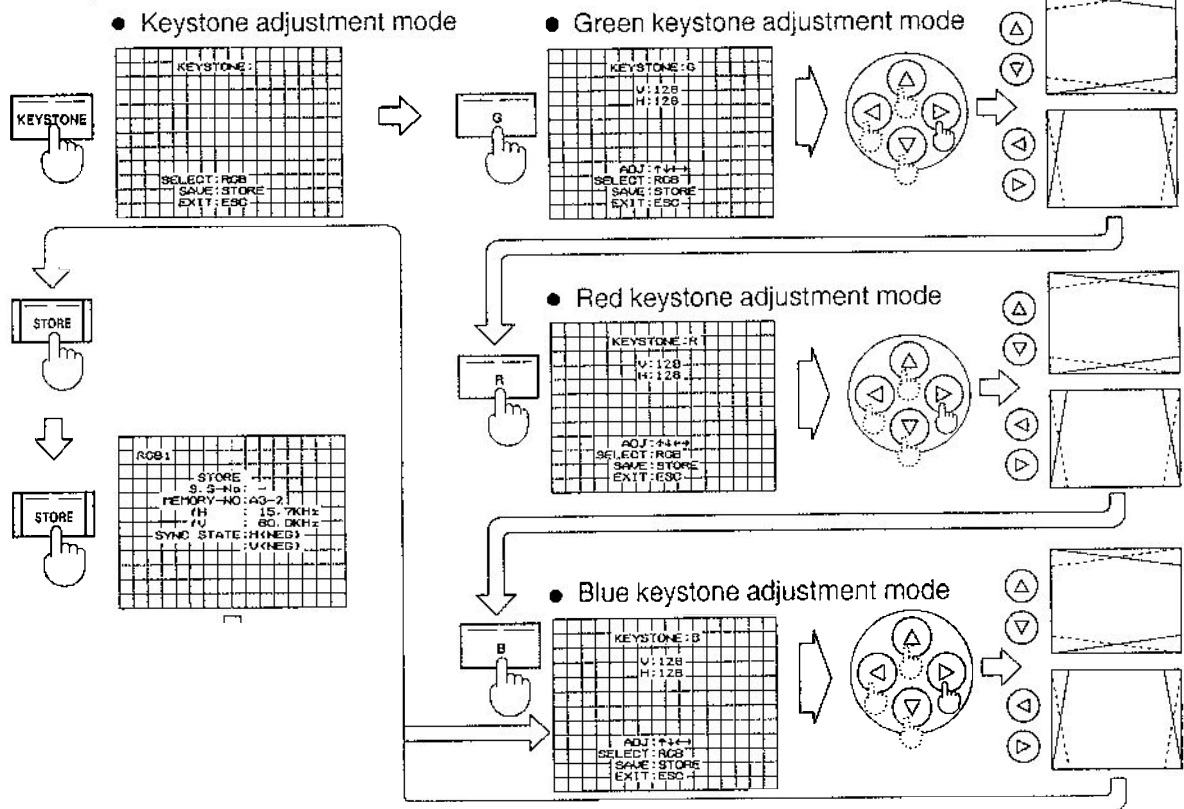

NOTE:

- In addition to using the above method, the keystone settings can also be saved by pressing the STORE button twice to store the changes after each color has been adjusted.
- If you would like to clear the adjustment settings, turn off the power for the projector without pressing the STORE button. The adjusted settings cannot be cleared once the STORE button has been pressed twice.

17. KEYSTONE BALANCE button

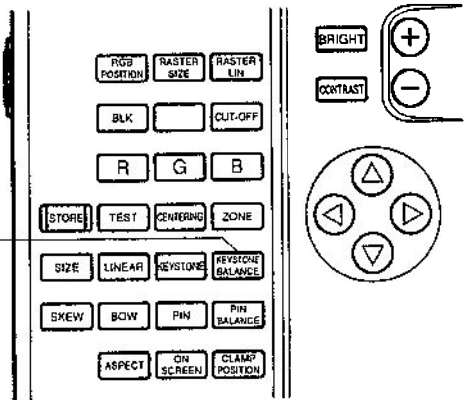

17. KEYSTONE BALANCE button



This button is used to switch to dynamic convergence adjustment mode for adjusting the balance for the keystone (orthogonality) of the green (G) picture segment.

- Setting is possible once the TEST button has been pressed so that a test pattern is displayed on the screen.

NOTE:

- If proper keystone adjustment is not possible because the keystone balance is so poor, use this adjustment to correct the keystone balance.
- After pressing this button to switch to adjustment mode, the setting values can be adjusted by pressing the arrow buttons.

Button operation procedure

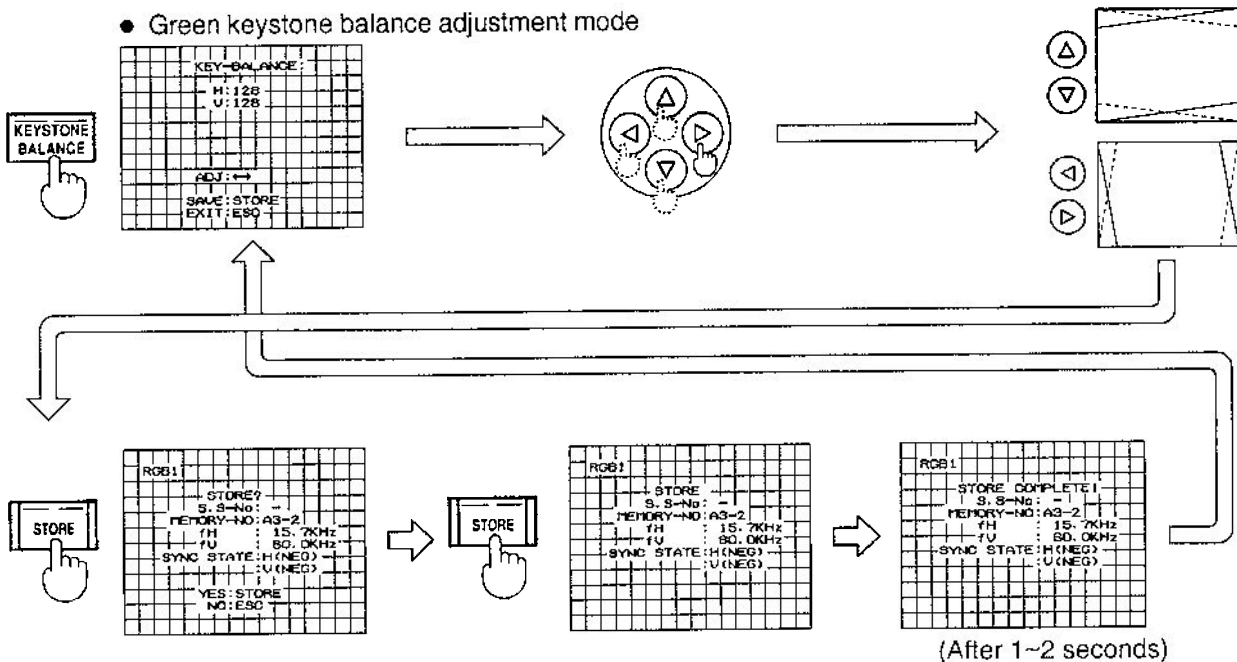

NOTE:

- If you would like to clear the adjustment settings, turn off the power for the projector without pressing the STORE button. The adjusted settings cannot be cleared once the STORE button has been pressed twice.

18. BOW button

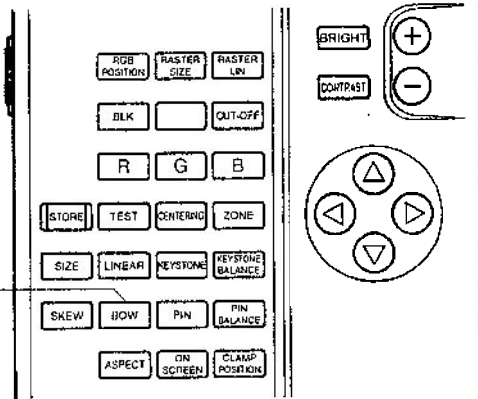

18. BOW button

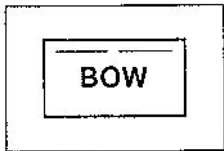

This button is used to switch to dynamic convergence adjustment mode for adjusting the bowing of the red (R), green (G) and blue (B) picture segments.

- Setting is possible once the TEST button has been pressed so that a test pattern is displayed on the screen.

Button operation procedure

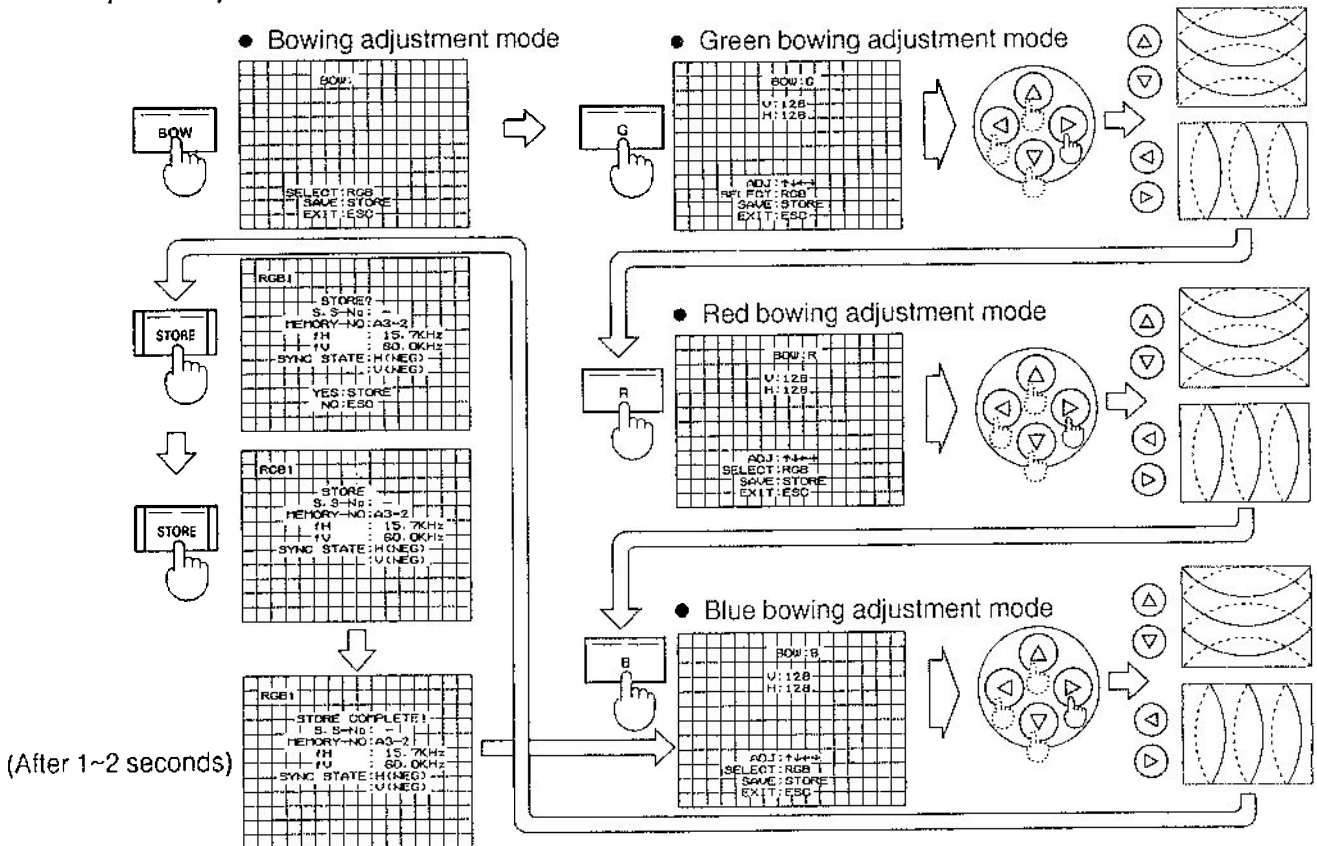

NOTE:

- In addition to using the above method, the bowing settings can also be saved by pressing the STORE button twice to store the changes after each color has been adjusted.
- If you would like to clear the adjustment settings, turn off the power for the projector without pressing the STORE button. The adjusted settings cannot be cleared once the STORE button has been pressed twice.

19. PIN (Pin cushion) button

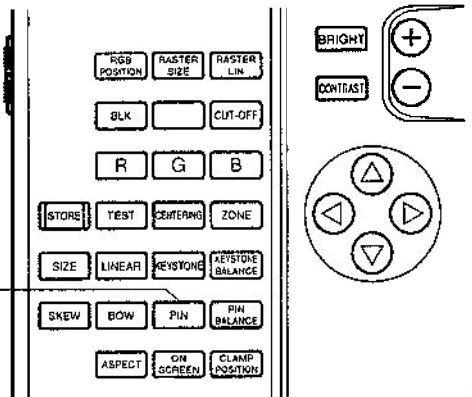

19. PIN (Pin cushion) button

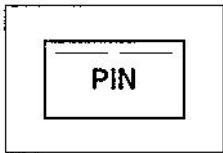

This button is used to switch to dynamic convergence adjustment mode for adjusting the pin cushion distortion of the red (R), green (G) and blue (B) picture segments.

- Setting is possible once the TEST button has been pressed so that a test pattern is displayed on the screen.
- When adjusting the green (G) size, all three colors will be adjusted at the same time.

Button operation procedure

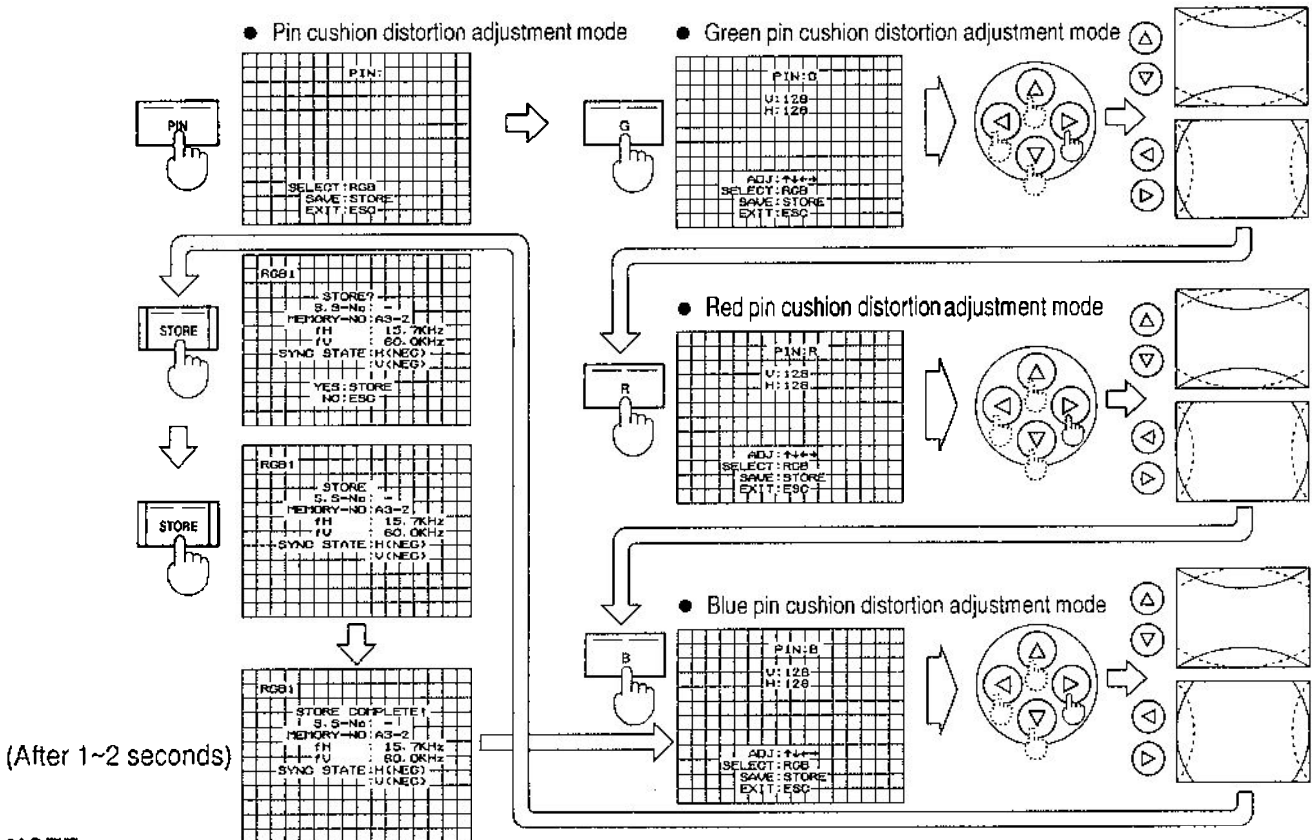

NOTE:

- In addition to using the above method, the pin cushion distortion settings can also be saved by pressing the STORE button twice to store the changes after each color has been adjusted.
- If you would like to clear the adjustment settings, turn off the power for the projector without pressing the STORE button. The adjusted settings cannot be cleared once the STORE button has been pressed twice.

20. PIN BALANCE button

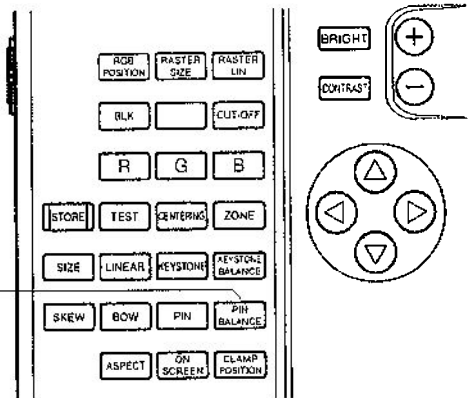

20. PIN BALANCE button



This button is used to switch to dynamic convergence adjustment mode for adjusting the balance for the pin cushion distortion of the red (R), green (G) and blue (B) picture segments.

- Setting is possible once the TEST button has been pressed so that a test pattern is displayed on the screen.

NOTE:

- If proper pin cushion distortion adjustment is not possible because the pin cushion balance is so poor, use this adjustment to correct the pin cushion distortion balance.

Button operation procedure

- Adjustment of pin cushion distortion balance for the green segment:

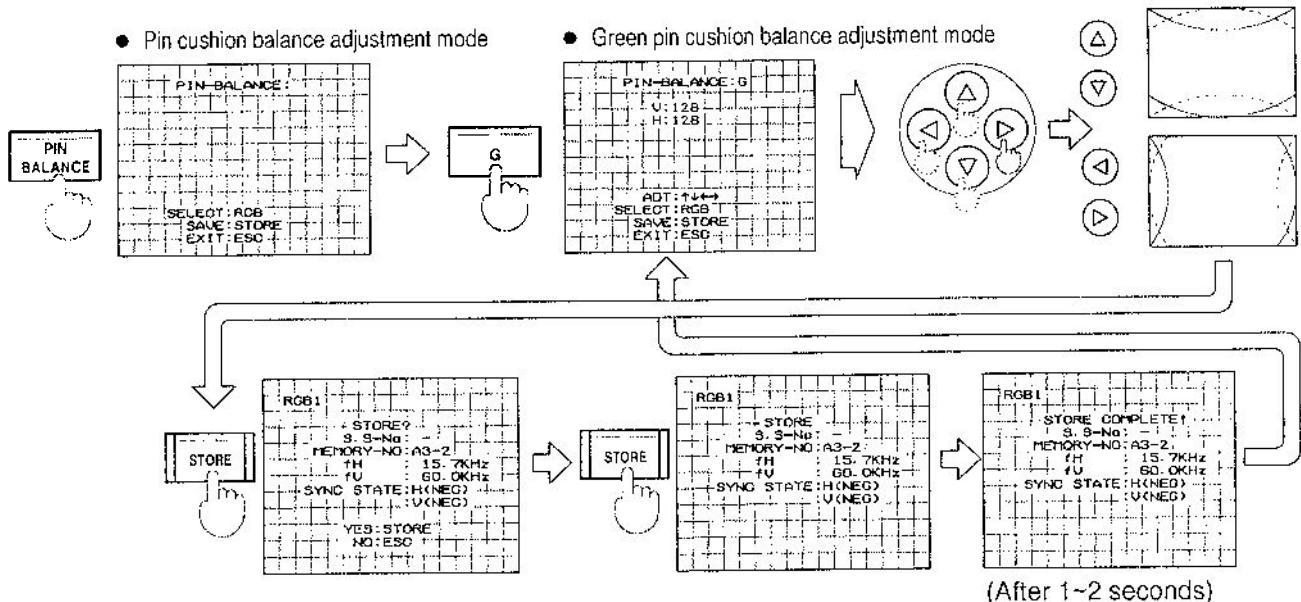

NOTE:

- If you would like to clear the adjustment settings, turn off the power for the projector without pressing the STORE button. The adjusted settings cannot be cleared once the STORE button has been pressed twice.
- The procedures for adjusting the blue and red pin balance are the same as that for the green pin balance given above.

21. CENTERING button

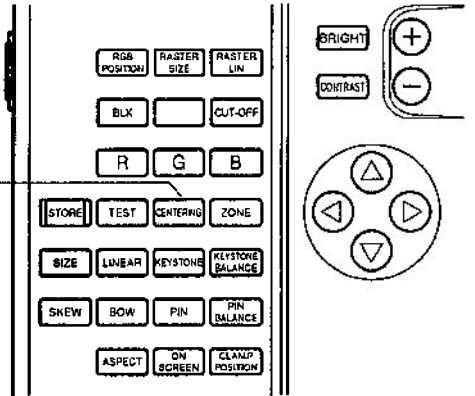

21. CENTERING button



This button is used to switch to convergence adjustment mode for adjusting the centering of the red (R), green (G) and blue (B) picture segments.

- Setting is possible once the TEST button has been pressed so that a test pattern is displayed on the screen.

Button operation procedure

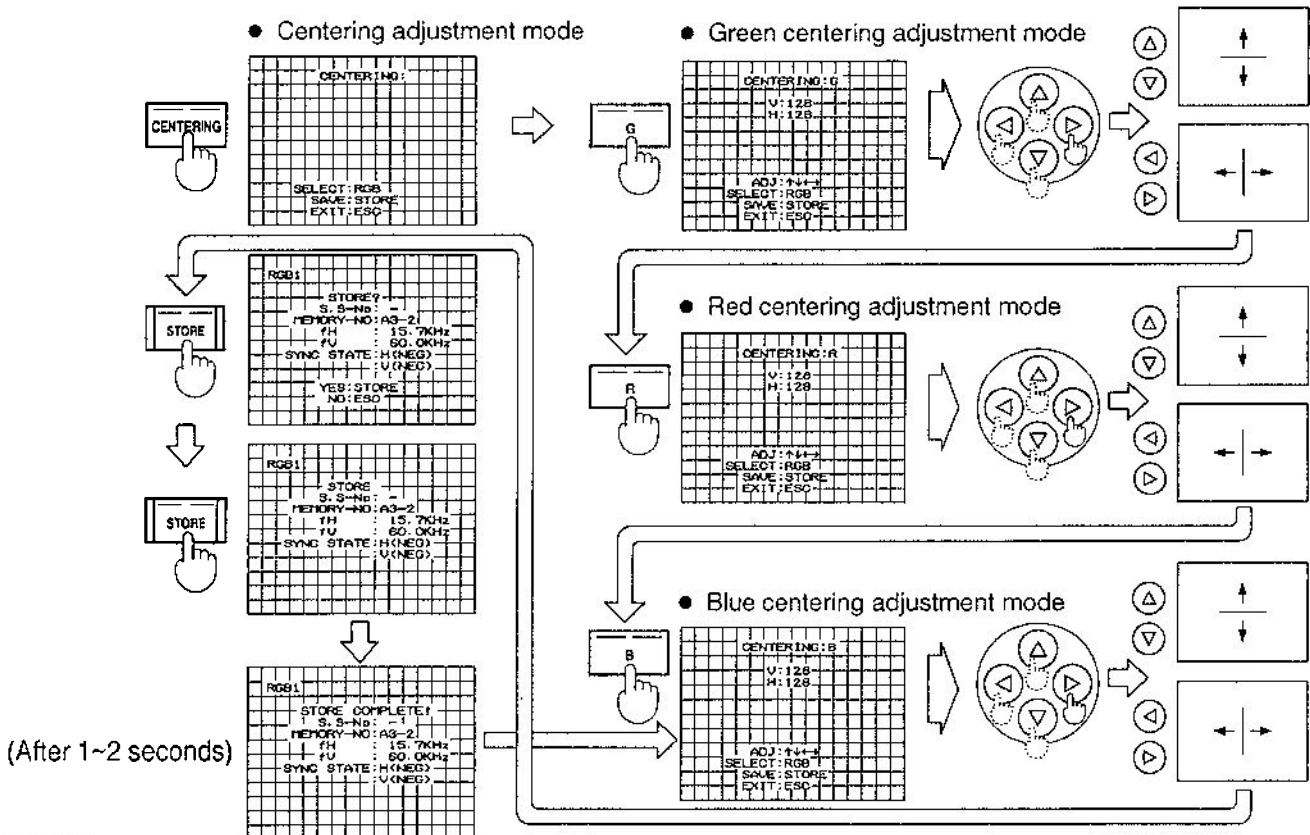

NOTE:

- In addition to using the above method, the centering settings can also be saved by pressing the STORE button twice to store the changes after each color has been adjusted.
- If you would like to clear the adjustment settings, turn off the power for the projector without pressing the STORE button. The adjusted settings cannot be cleared once the STORE button has been pressed twice.

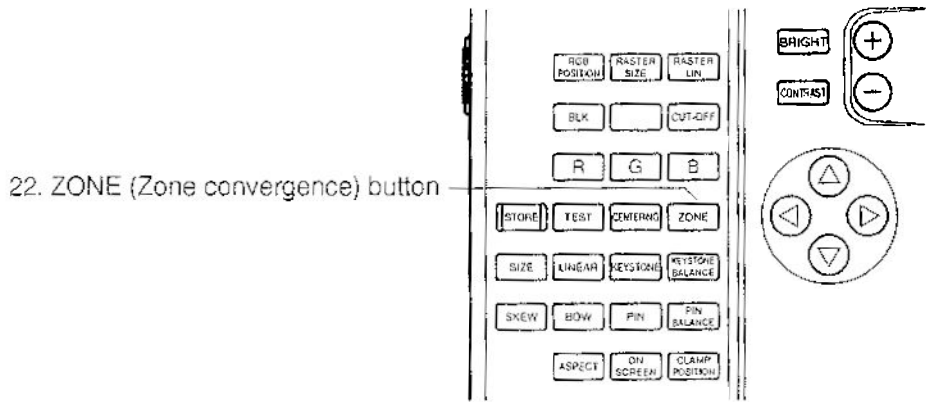

22. ZONE (Zone convergence) button



This button is used to switch to zone convergence adjustment mode for correcting partial color misalignments.

- Setting is possible once the TEST button has been pressed so that a test pattern is displayed on the screen.
- Zone convergence adjustment should be carried out only after all other convergence adjustments (SIZE, LIN, SKEW, BOW, KEYSTONE, KEYSTONE BALANCE, PIN, PIN BALANCE, CENTERING) have been completed.

Button operation procedure

- When adjusting the zone convergence for the red segment



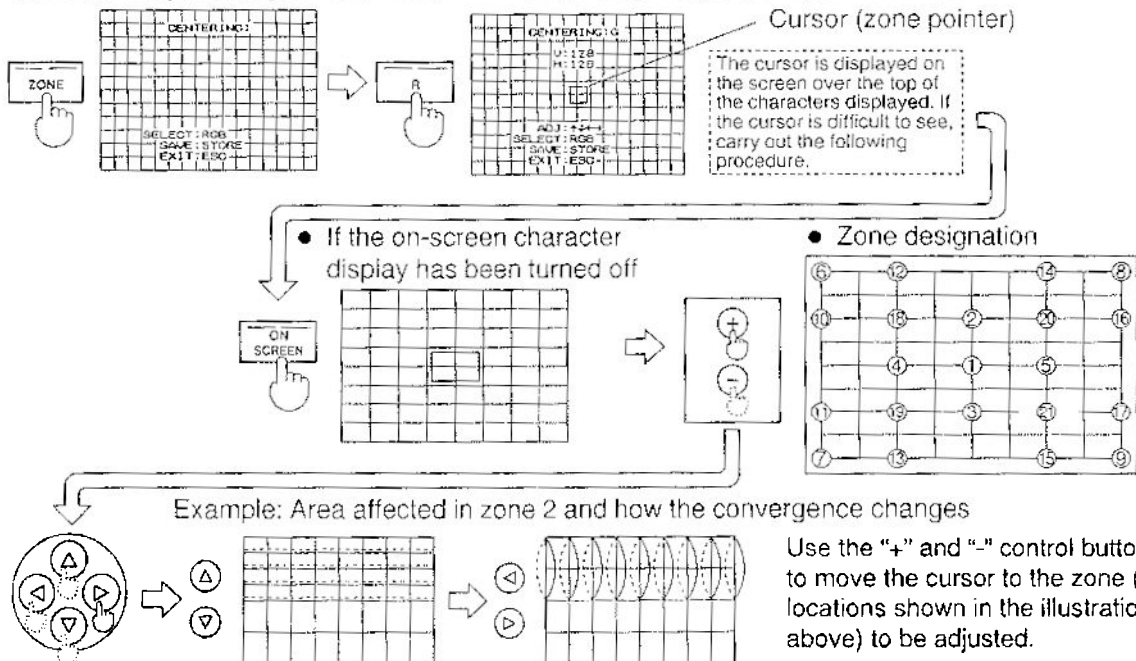







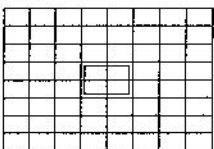
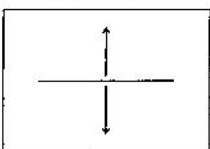

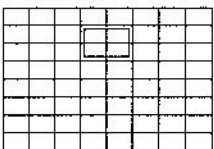
- Zone convergence adjustment mode
- Red zone convergence adjustment mode

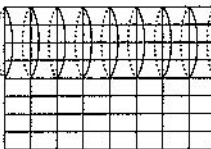
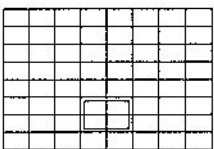

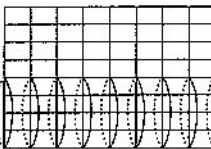

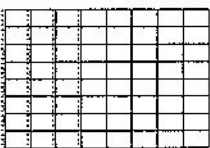
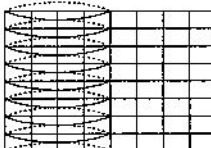

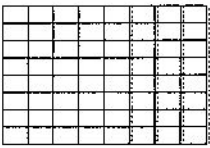
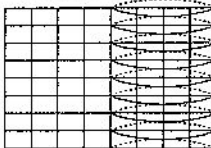
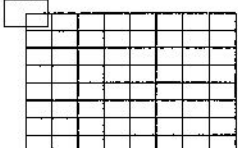
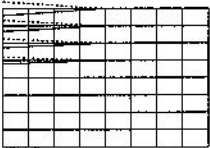
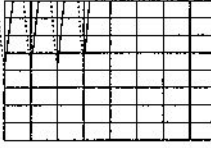
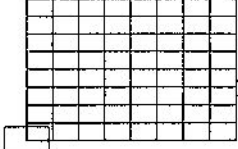
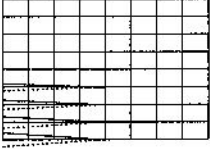
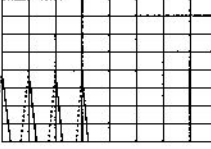
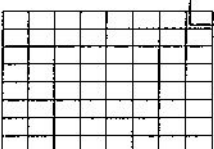
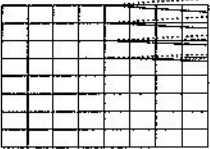

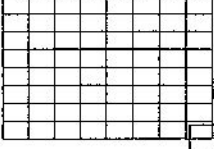
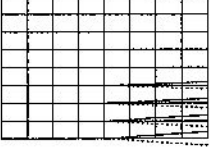
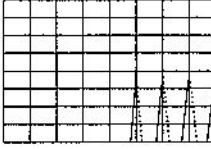
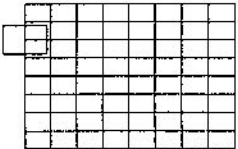
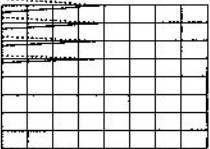
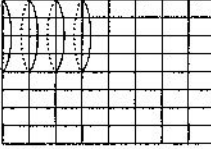

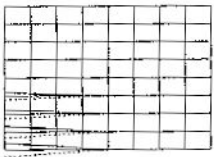
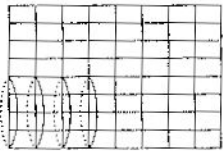

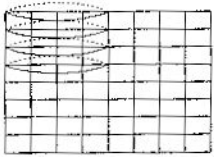
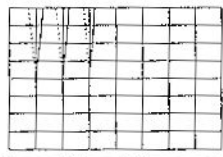
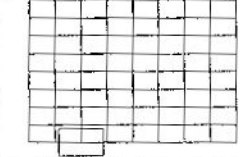
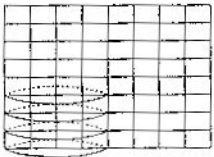
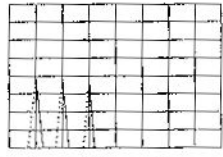
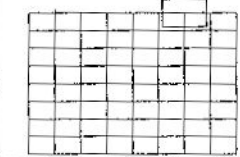
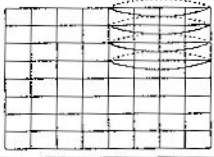

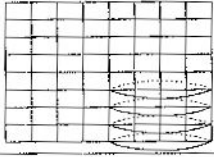



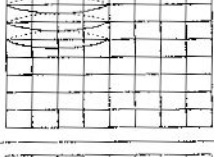

NOTE:

- Be sure to press the STORE button twice to register the changes after zone convergence adjustment is completed.
- The area affected and the way that the convergence changes are different for each zone number. Refer to the following page for details.
- The procedure for adjusting the blue zone convergence is the same as that for the red zone convergence given above.

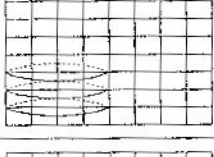
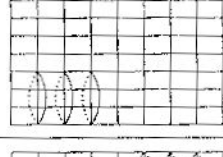
Adjustment range and change in convergence for each zone

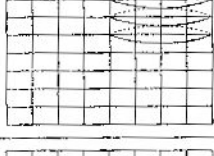
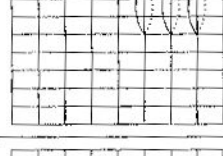
Zone No.	Cursor position	Adjustment range	Vertical change in convergence	Horizontal change in convergence	Remarks
ZONE1		Whole of picture			Same as for centering adjustment
ZONE2		Upper half of picture			
ZONE3		Lower half of picture			
ZONE4		Left half of picture			
ZONE5		Right half of picture			
ZONE6		Upper-left quadrant of picture			
ZONE7		Lower-left quadrant of picture			
ZONE8		Upper-right quadrant of picture			
ZONE9		Lower-right quadrant of picture			
ZONE10		Upper-left quadrant of picture			

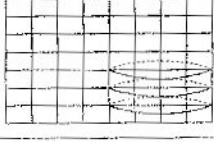
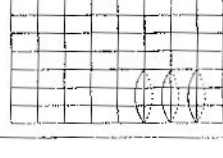
ZONE11		Lower-left quadrant of picture			
ZONE12		Upper-left quadrant of picture			
ZONE13		Lower-right quadrant of picture			
ZONE14		Upper-right quadrant of picture			
ZONE15		Lower-right quadrant of picture			
ZONE16		Upper-right quadrant of picture			
ZONE17		Lower-right quadrant of picture			
ZONE18		Upper-left quadrant of picture			
ZONE19		Lower-left quadrant of picture			
ZONE20		Upper-right quadrant of picture			
ZONE21		Lower-right quadrant of picture			

23. COLOR TEMP button

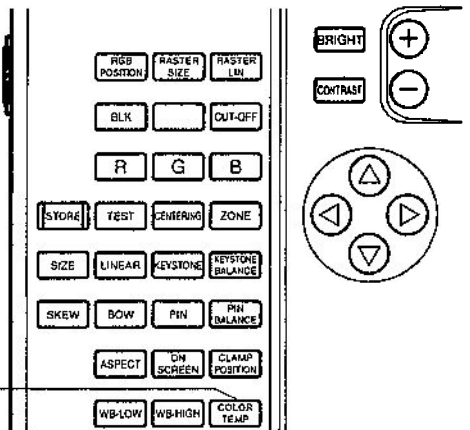

23. COLOR TEMP button

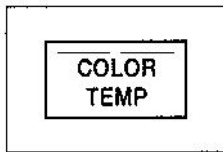

This button is used to change the color temperature of the picture.

- The color temperature of the picture changes between LOW, MID (medium) and HIGH each time this button is pressed.

Button operation procedure

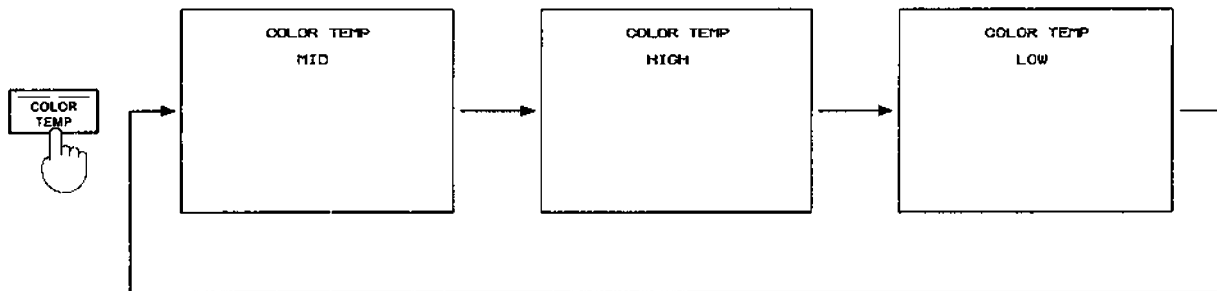

COLOR TEMP MIDThe color temperature is set to the standard whiteness which has been adopted throughout the world.

COLOR TEMP HIGHThe color temperature is set to a blue-tinged whiteness.

COLOR TEMP LOWThe color temperature is set to the red-tinged whiteness which is commonly used in video cameras, etc.

NOTE:

- The characters displayed on the screen will be cleared approximately 10 seconds after the button is released.

24. WB-HIGH (White balance highlight) button

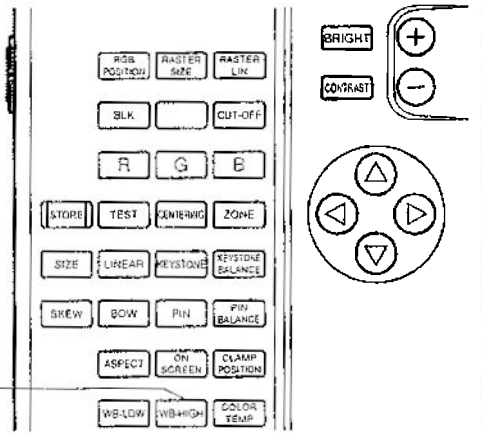

24. WB-HIGH (White balance highlight) button



This button is used to switch to the mode for adjusting the degree of white balance highlight.

- Press the WB-HIGH button after the TEST button has been pressed so that a test pattern is displayed on the screen. The screen will change to a full white pattern and the mode will then switch to highlight adjustment mode.

Button operation procedure

- For red highlight adjustment

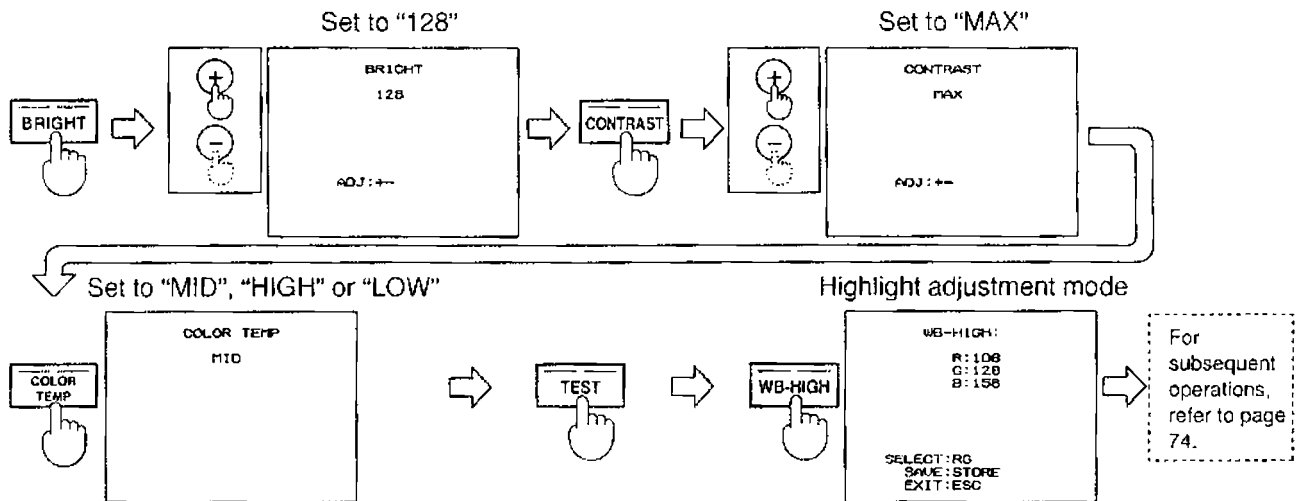

NOTE:

- It is necessary to repeatedly set the white balance highlight and lowlight settings one after the other in order to get the correct setting. Furthermore, use the COLOR TEMP button to switch to each of the MID, HIGH and LOW color temperature settings and make the highlight and lowlight adjustments for each color temperature setting.
- When the color temperature setting is LOW or MID, red (R) and blue (B) can be adjusted. When the color temperature setting is HIGH, red (R) and green (G) can be adjusted.
- At least some prior settings need to have been made before highlight adjustment can be carried out.
- For the adjustment method, refer to "25. WB-LOW (White balance lowlight) button" on the following page.

25. WB-LOW (White balance lowlight) button

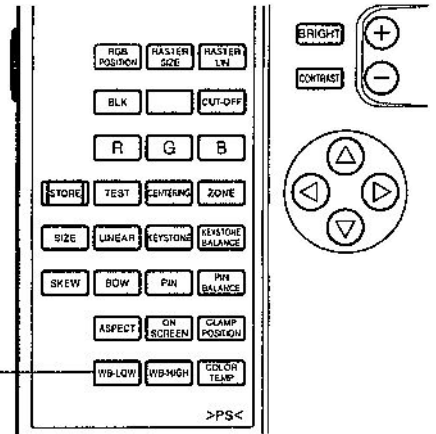

25. WB-LOW (White balance lowlight) button

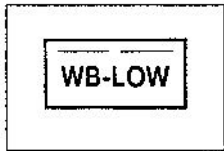

This button is used to switch to the mode for adjusting the degree of white balance lowlight.

- Press the WB-LOW button after the TEST button has been pressed so that a test pattern is displayed on the screen. The screen will change to a pluge pattern and the mode will then switch to lowlight adjustment mode.

Button operation procedure

- For green lowlight adjustment

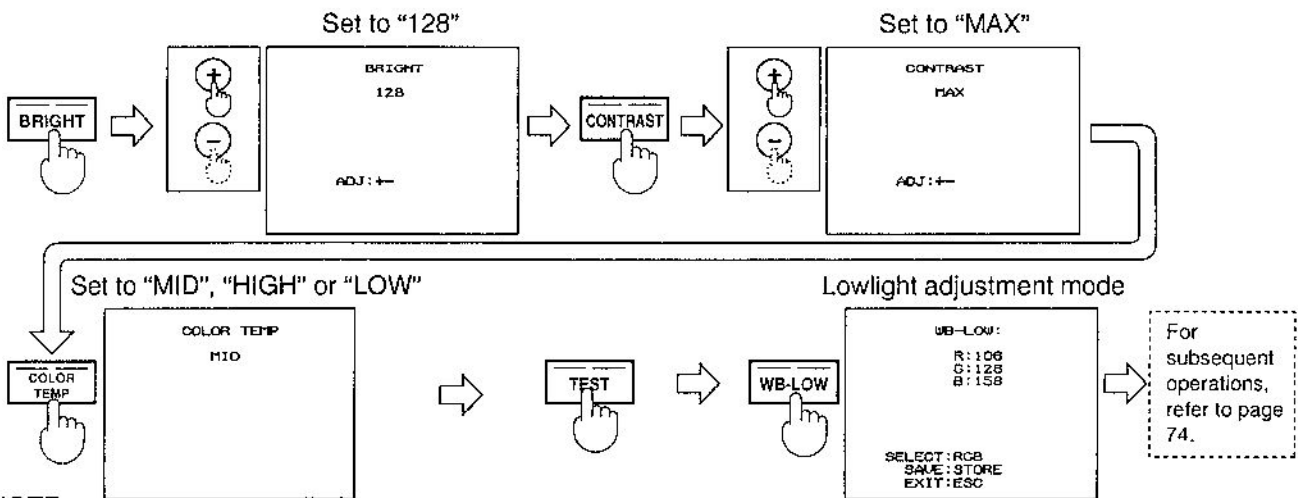

NOTE:

- It is necessary to repeatedly set the white balance highlight and lowlight settings one after the other in order to get the correct setting. Furthermore, use the COLOR TEMP button to switch to each of the MID, HIGH and LOW color temperature settings and make the highlight and lowlight adjustments for each color temperature setting.
- The following buttons need to be set as indicated before the white balance can be adjusted.

BRIGHT button CONTRAST button COLOR TEMP button	Set to "128" Set to "MAX" White balance adjustment needs to be carried out for each of the MID, HIGH and LOW settings.
Test pattern	Full white pattern signal, Pluge pattern signal (The pattern switches automatically when the WB-HIGH and WB-LOW buttons are pressed.)

- For the button operation procedure for lowlight and highlight adjustment, refer to the following page.

Button operation procedure for lowlight and highlight adjustment

Firstly, use the projector control panel or the remote control in normal mode to set BRIGHT to 128 and CONTRAST to MAX. Next, switch the remote control to service mode and adjust by the following procedure.

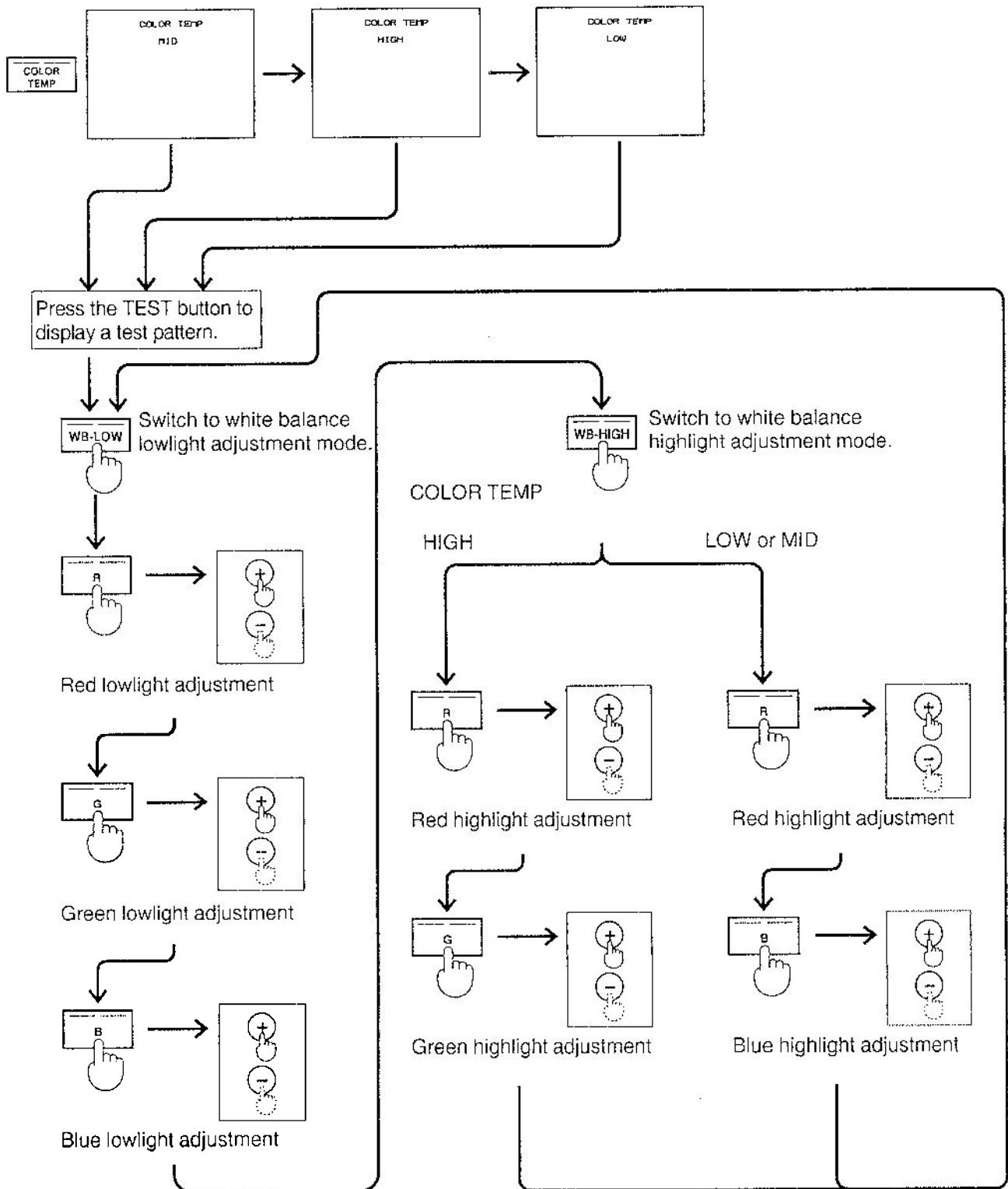

NOTE:

- Repeat the lowlight and highlight adjustment procedure 2~3 times.
- If lowlight adjustment is difficult, set the adjustment levels as follows.
R: 155, G: 128, B: 225
- After white balance adjustment is completed, press the STORE button twice to register the changed settings.

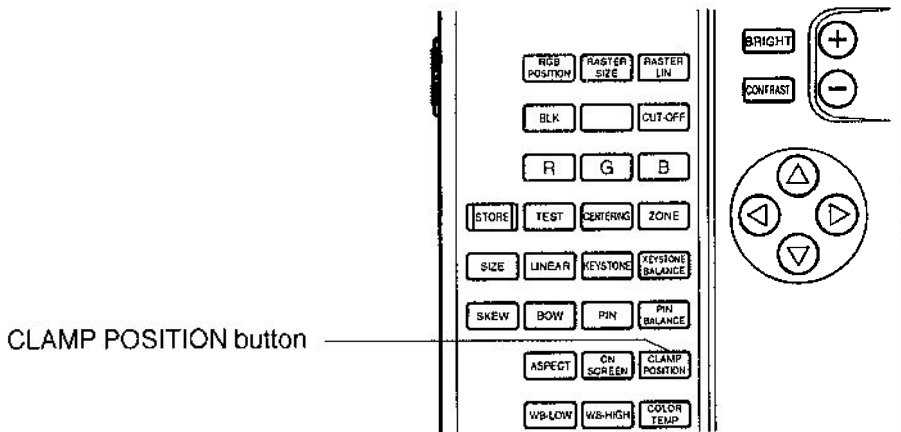

CLAMP POSITION button

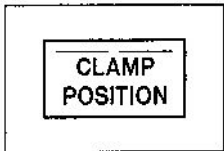

This button is used to switch the clamp position for the black level of the video signal.

- Setting is possible once the TEST button has been pressed so that a test pattern is displayed on the screen.

NOTE:

- The clamp position should normally be set to AUTO.
- Set the clamp position to "DELAY", when the following condition occurs.
(Check the picture while displaying an external signal.)
 - ① Only the green component of the picture is darker when a 3-level G-sync signal is input.
 - ② Only the green component of the picture is brighter when both G-sync and H, V-sync signals are input.

Button operation procedure

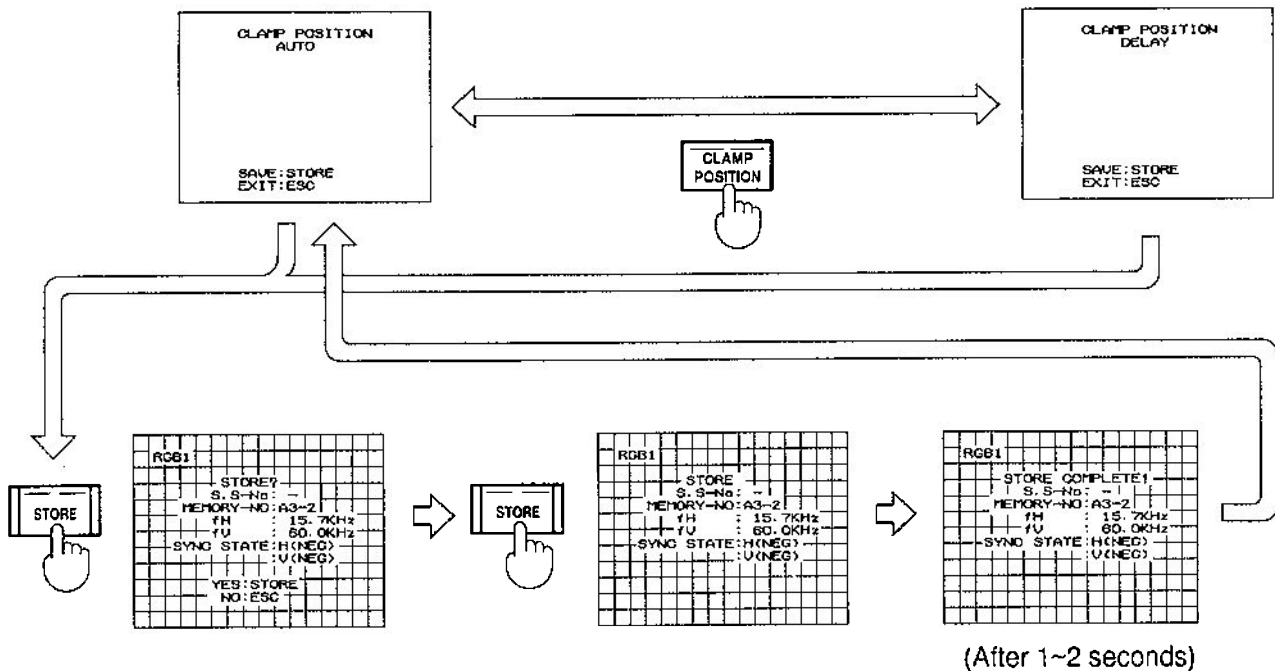

NOTE:

- If you would like to clear the adjustment settings, turn off the power for the projector without pressing the STORE button. The adjusted settings cannot be cleared once the STORE button has been pressed twice.