

SONY[®]

4-490-302-21 (1)

COLOR VIDEO PROJECTOR

VPH-1031Q

INSTALLATION MANUAL FOR DEALERS page 2

Before operating the unit, please read this manual thoroughly and retain it for future reference.

MANUEL D'INSTALLATION DU CONCESSIONNAIRE page 18

Avant la mise en service de cet appareil, prière de lire attentivement ce mode d'emploi que l'on conservera pour toute référence ultérieure.

MULTISCAN

Installation possibilities	2
System installation procedure	3
Installation diagrams	4
Notes on installation	10
Polarity change	12
Lens focus adjustment	13
Registration adjustment	14
Conversion for 72" (67") or 200" (150"—250") projection	16

INSTALLATION POSSIBILITIES

For 100' projection				
Installation place	Desk	Floor	Ceiling	
Screen to be used	VPS-100F1 flat screen	VPS-100HG1 curved screen	VPS-100F1 flat screen	VPS-100HG1 curved screen
Accessory for installation	—	SU-722 pedestal	PSS-722 suspension support	
Type of installation	1	2	3	4

For 72' projection*				
Installation place	Desk	Floor	Ceiling	
Screen to be used	VPS-100F1 flat screen	VPS-72HG1 curved screen	VPS-100F1 flat screen	VPS-72HG1 curved screen
Accessory for installation	—	SU-722 pedestal	PSS-722 suspension support	
Type of installation	5	6	7	8

For 100"—250" projection*		
Installation place	Floor	Ceiling
Screen to be used	100"—250" flat screen	
Accessory for installation	—	PSS-722 suspension support
Type of installation	9	10

* For 72" or 150"—250" projection, internal conversion is necessary.

First perform conversion, referring to pages 16 and 17.

Types of installation:

The same numbers are used for the system installation procedure and the installation diagrams in this manual.

SYSTEM INSTALLATION PROCEDURE

	Type of installation									
	1	2	3	4	5	6	7	8	9	10
1 Install the screen. (See pages 4 to 9 and screen's installation manual.)	1	1	1	1	1	1	1	1	1	1
2 Place the projector on the desk. (See pages 4 and 6.)	2				2				2	
3 Place the projector on the SU-722 pedestal. (See pages 4 and 6 and SU-722's installation manual.)		3				3				
4 Change the polarity. (See page 12.)			4	4			4	4		4
5 Install the PSS-722 suspension support to the ceiling and attach the projector to the PSS-722. (See pages 5, 7 and 8 and PSS-722's installation manual.)			5	5			5	5		5
6 Adjust the lens focus. (See page 13.)		6		6	6	6	6	6	6	6
7 Adjust the registration. (See page 14.)		7		7	7	7	7	7	7	7
8 Make the connections. (See the projector's instruction manual.)	8	8	8	8	8	8	8	8	8	8

INSTALLATION DIAGRAMS

Type 5

72" projection
Desk top
Flat screen

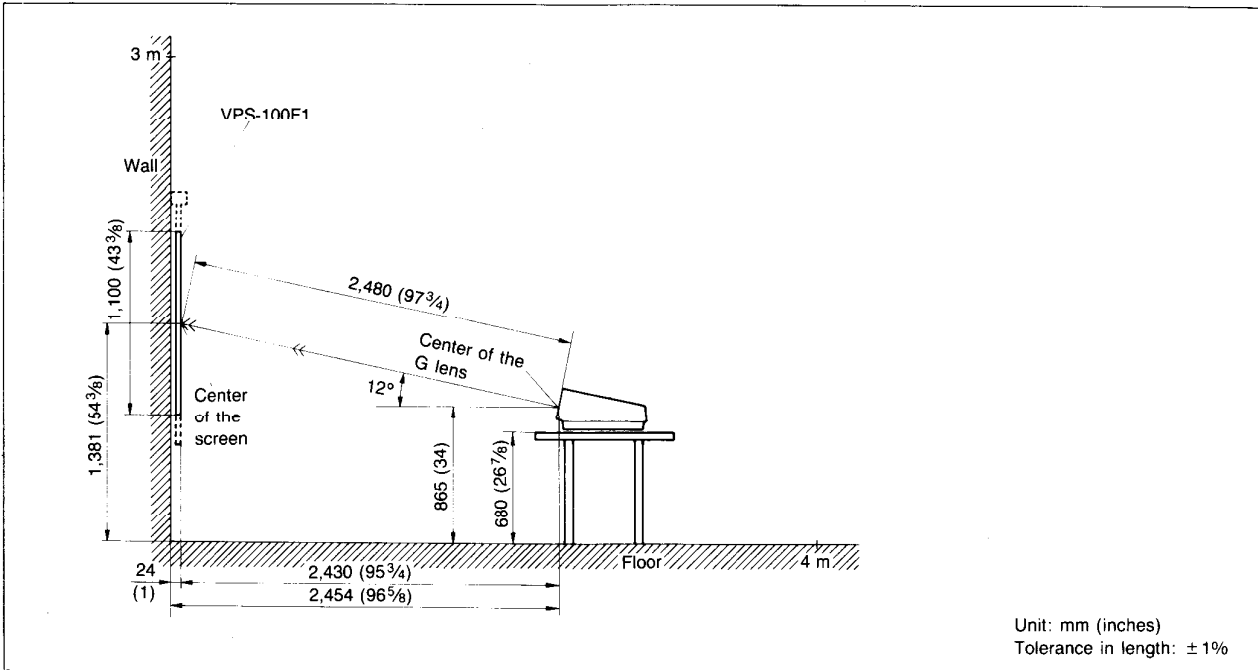

Type 6

72" projection
Floor
Curved screen

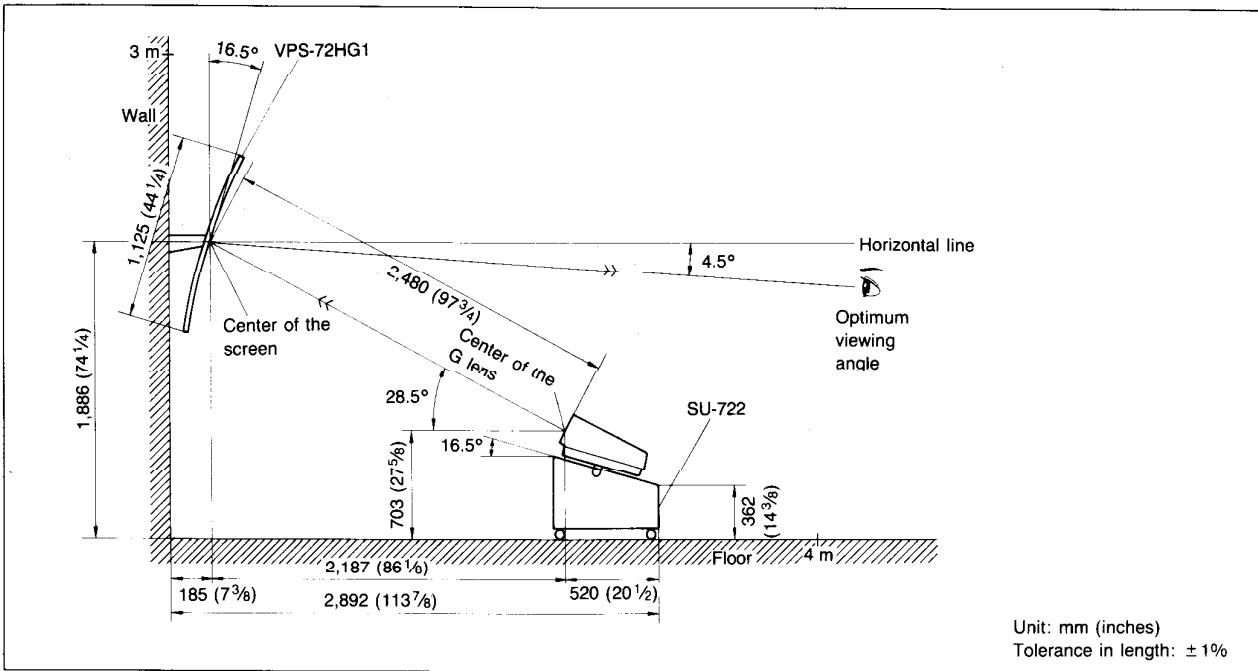

Type 7

72" projection
Ceiling
Flat screen

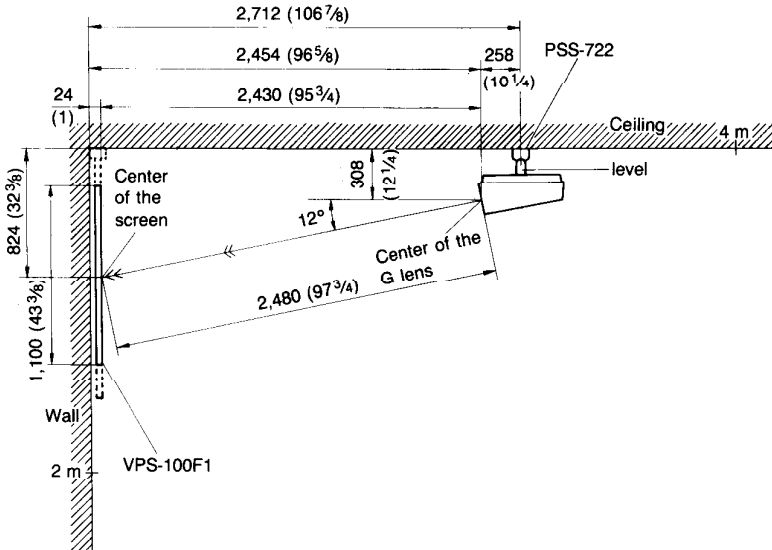

Unit: mm (inches)
Tolerance in length: ± 1%

Type 8

72" projection
Ceiling
Curved screen

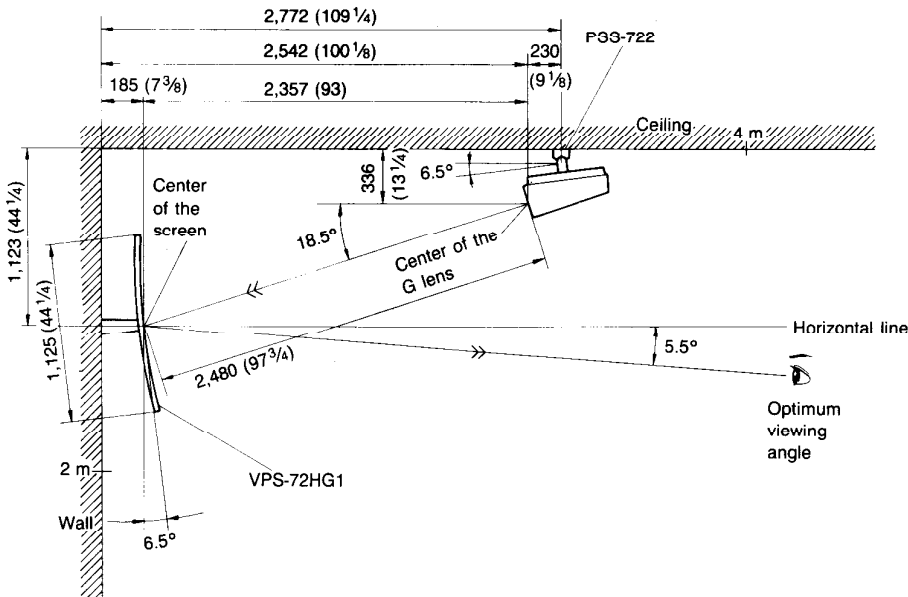

Unit: mm (inches)
Tolerance in length: ± 1%

INSTALLATION DIAGRAMS

Type 9

100" - 250" projection
Floor
Flat screen

Decide the length, height, and depth according to the screen size to be used.

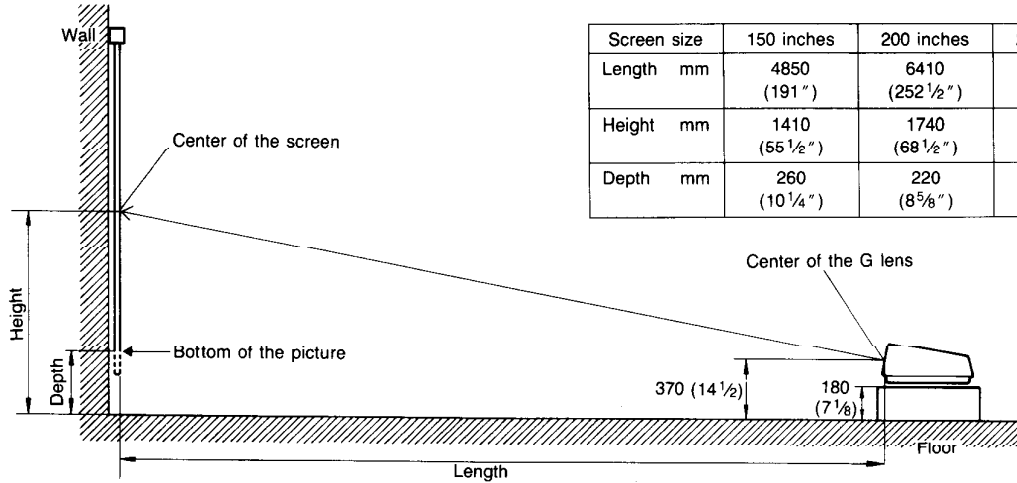

Screen size	150 inches	200 inches	250 inches
Length mm	4850 (191")	6410 (252 1/2")	7960 (313 1/2")
Height mm	1410 (55 1/2")	1740 (68 1/2")	2080 (82")
Depth mm	260 (10 1/4")	220 (8 5/8")	170 (6 3/4")

Unit: mm (inches)
Tolerance in length: ± 1%

Type 10

100" - 250" projection
Ceiling
Flat screen

Decide the length, height, and depth according to the screen size to be used.

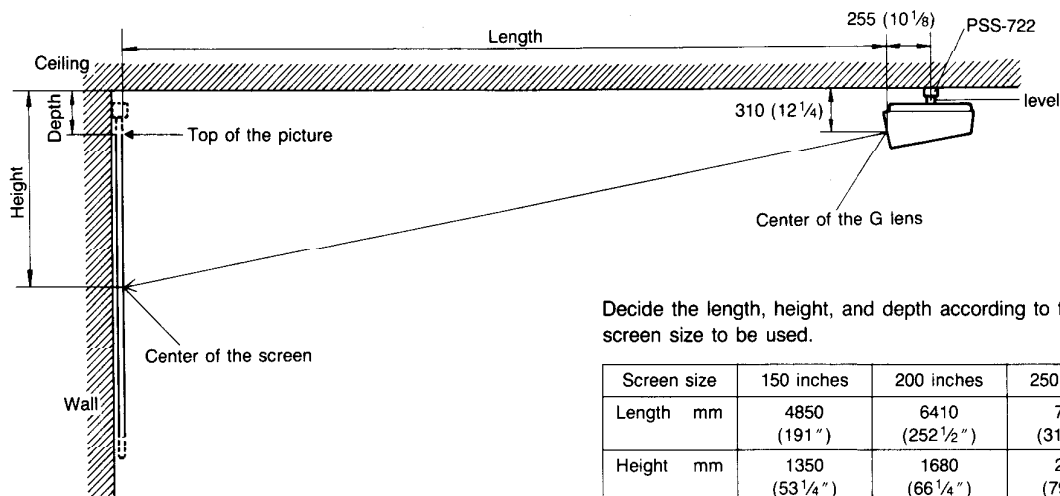

Screen size	150 inches	200 inches	250 inches
Length mm	4850 (191")	6410 (252 1/2")	7960 (313 1/2")
Height mm	1350 (53 1/4")	1680 (66 1/4")	2020 (79 1/2")
Depth mm	200 (7 7/8")	160 (6 3/8")	110 (4 3/8")

Unit: mm (inches)
Tolerance in length: ± 1%

Type 9 and 10

72" - 250" projection

For a screen not described on page 8, use the following graph to decide the length (L).

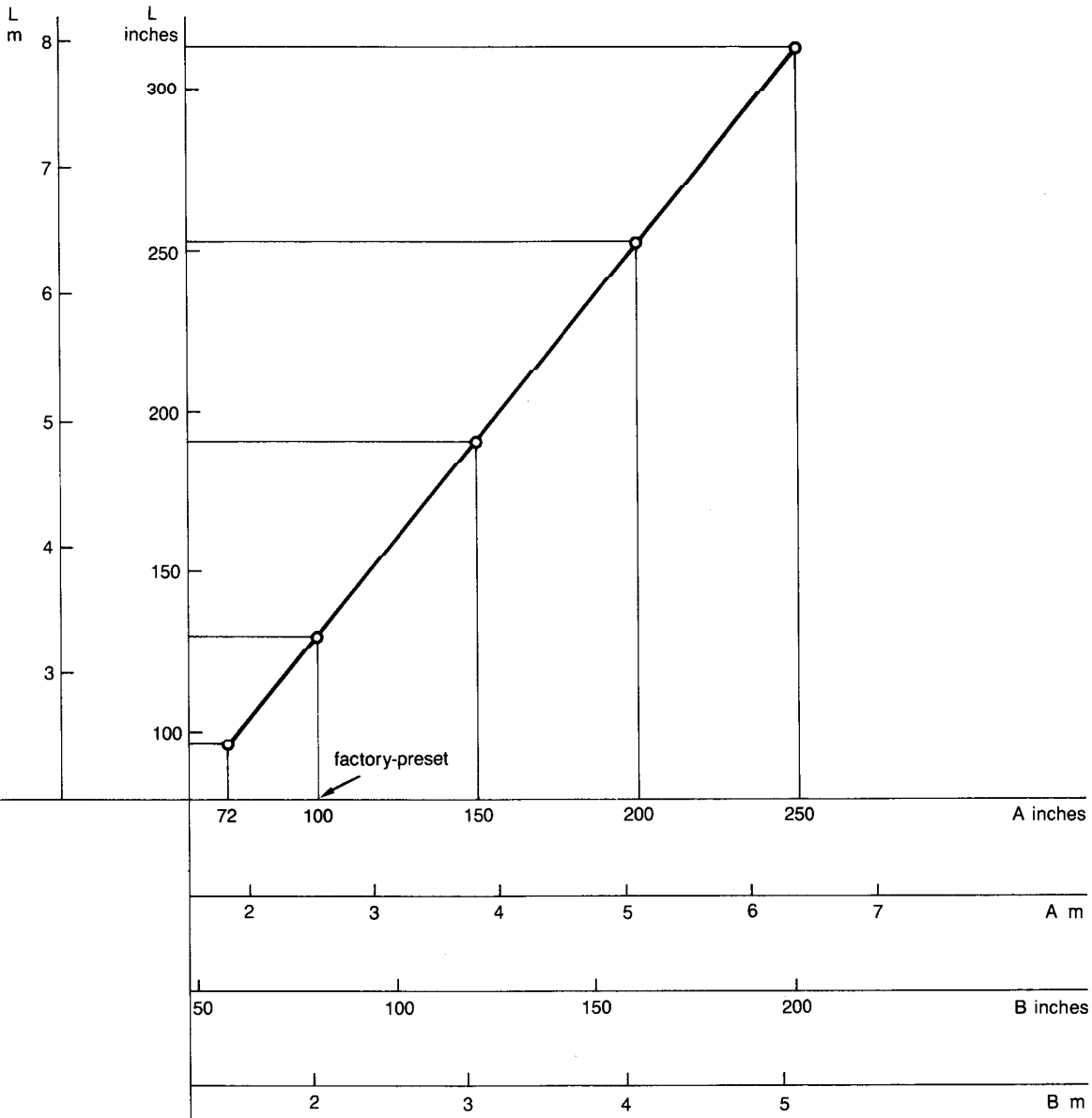

Viewable area of the screen

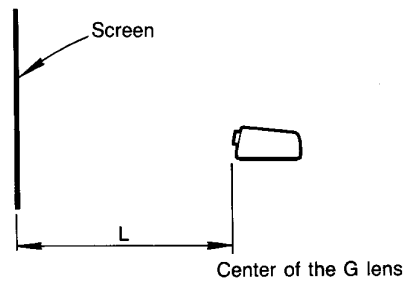
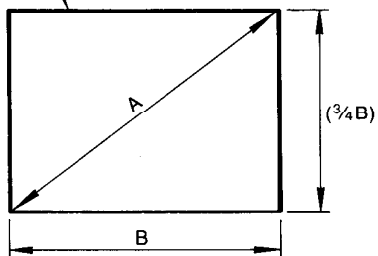

NOTES ON INSTALLATION

PROJECTOR'S DIMENSIONS

Unit: mm (inches)

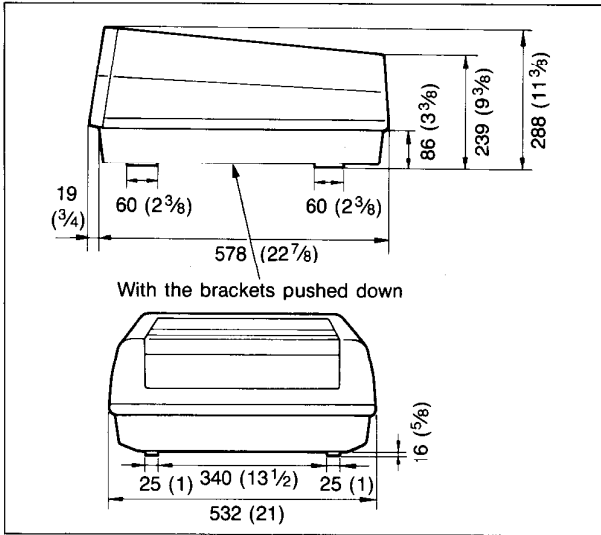

Raise the brackets when installing the projector on the ceiling or floor.

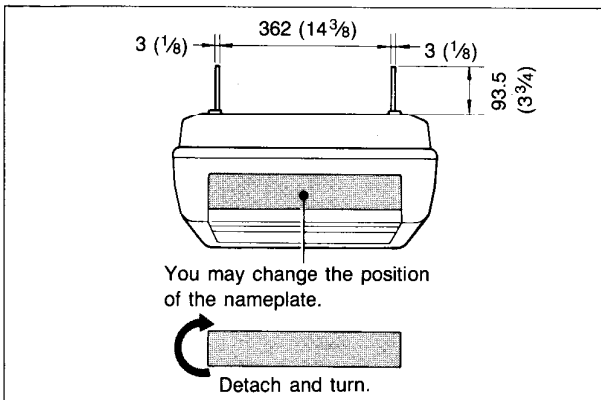
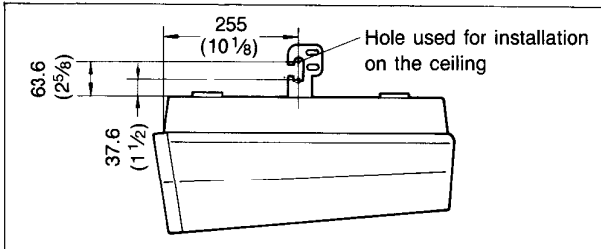
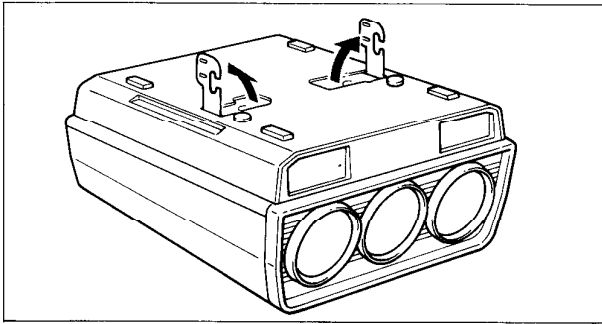

TO ADJUST THE ANGLE OF THE SCREEN/PROJECTOR

Loosen the knobs, adjust the angle, then tighten the knobs down firmly.

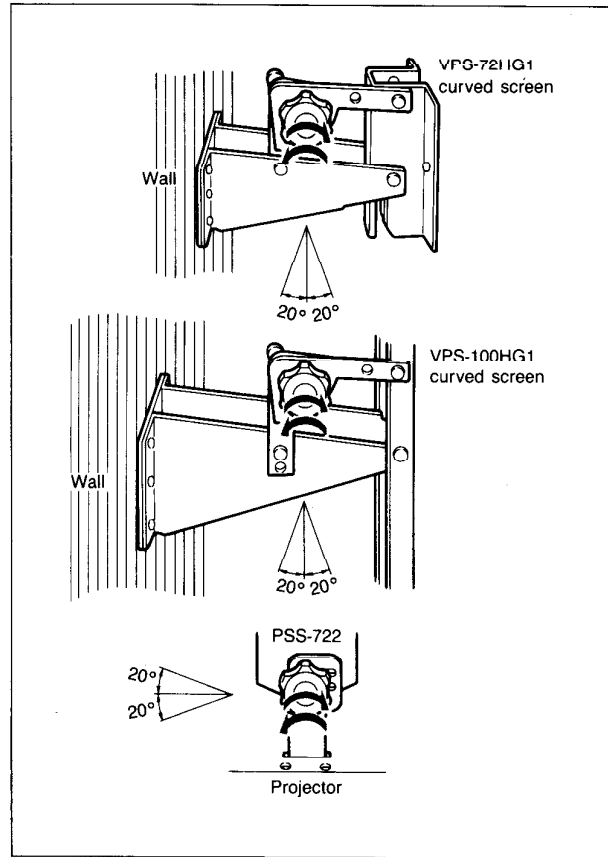

When the PSS-10 projector suspension support (optional) is used in combination with the PSS-722 The PSS-10 allows you to adjust the distance between the ceiling and the projector.

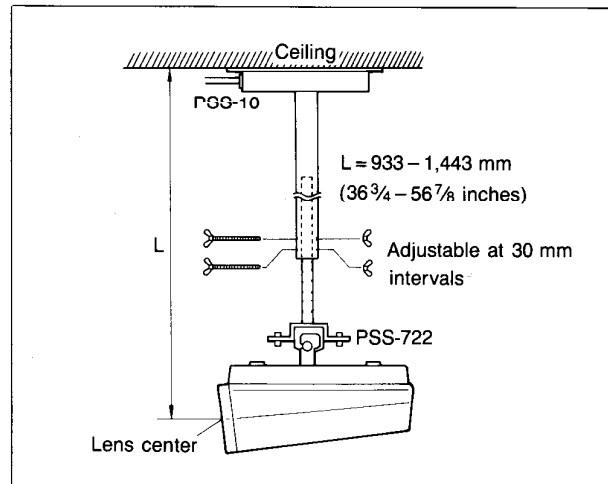

TO OPEN THE TOP PANEL

You will need a medium size Phillips head screwdriver.

- 1 Open the control panel cover.
- 2 Remove the two screws.

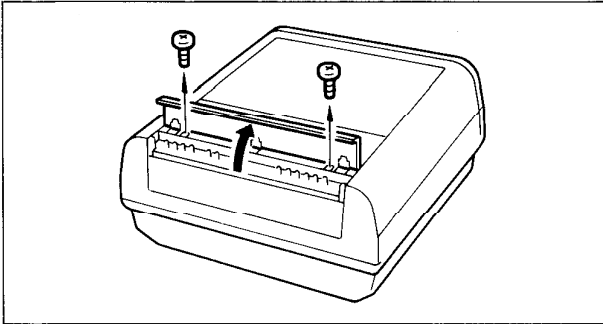

- 3 Pull the top panel slightly toward you and remove it.

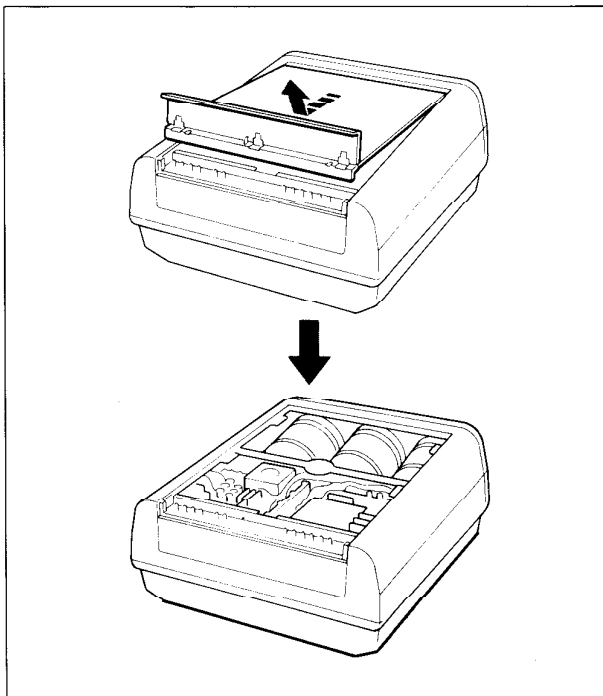

TO OPEN THE CABINET

Open the cabinet when changing the polarity and when converting the unit for 72" or 200" projection.

- 1 Open the control panel cover.
- 2 Remove the two screws on the control panel.

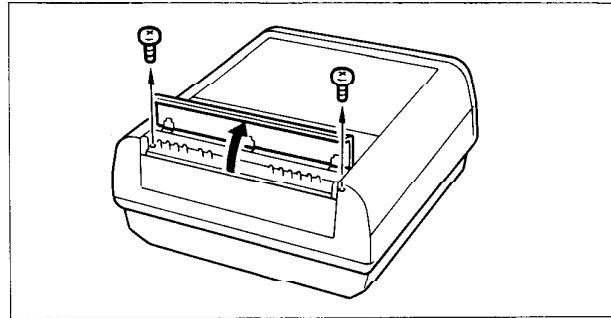

- 3 Slide the nameplate upward and pull it toward you to remove.

- 4 Remove the control panel.

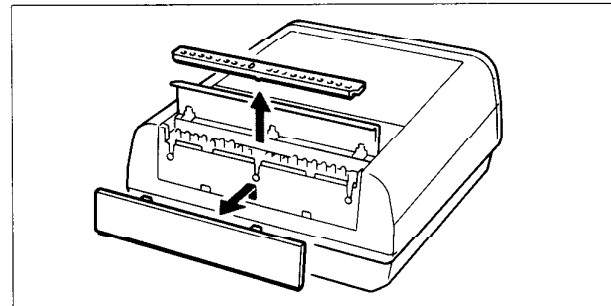

- 5 Remove the three screws.

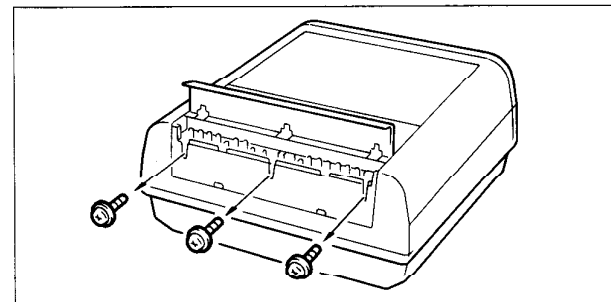

- 6 Slightly raise the cabinet and pull it toward you to remove.

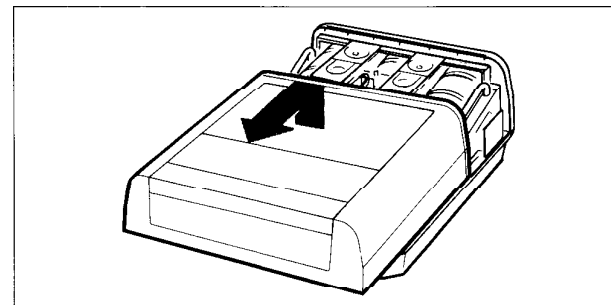

POLARITY CHANGE

The projector is preadjusted at the factory for use on desk or floor with the bracket side down. When the projector is installed on the ceiling with the bracket side up, the polarity should be changed.

- 1 Make sure that power is not connected.
- 2 Open the cabinet. (See page 11.)
- 3 Raise the DB circuit board to expose the DA circuit board.

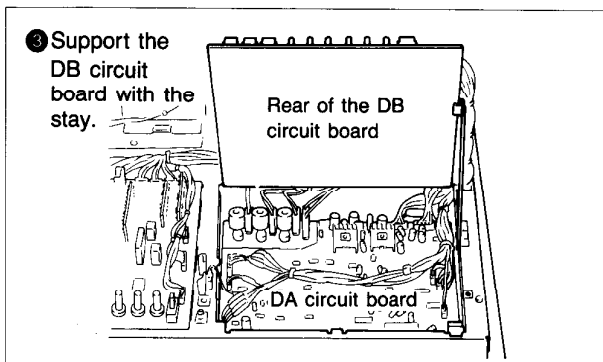
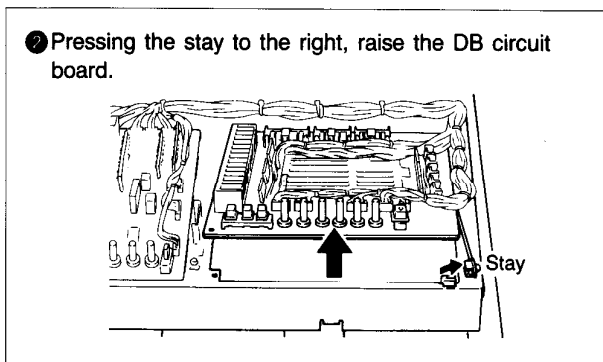
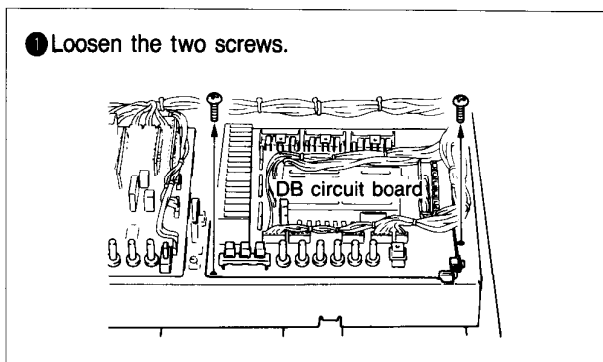

- 4 Reverse the polarity of connectors DA-14, 15 and 16.

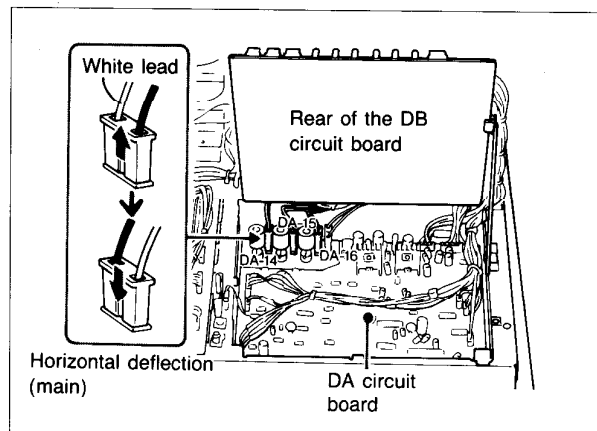

- 5 Replace the DB circuit board.
- 6 Move the connectors from receptacles DB-7, 9, 11, 13, 15, 17, 19, 21 and 23 to receptacles 6, 8, 10, 12, 14, 16, 18, 20 and 22 respectively.

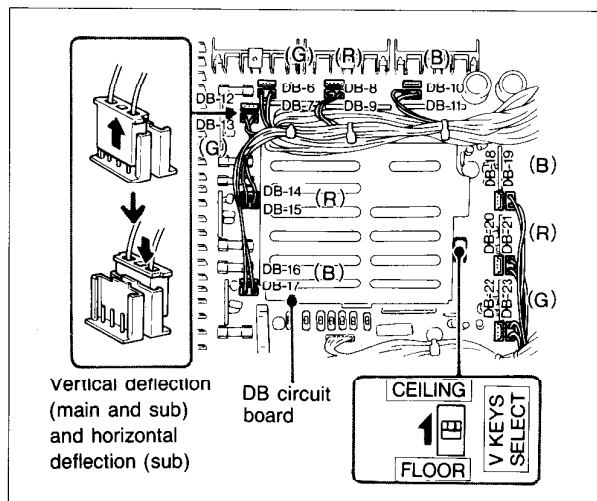

- 7 Set the V KEYS SELECT switch to the CEILING position.

Note

Check that the connectors are inserted firmly, then proceed to lens focus adjustment with the projector's cabinet removed.

LENS FOCUS ADJUSTMENT

The lens focus is preadjusted at the factory for 100" flat screen. For other type screens, the lens focus should be adjusted.

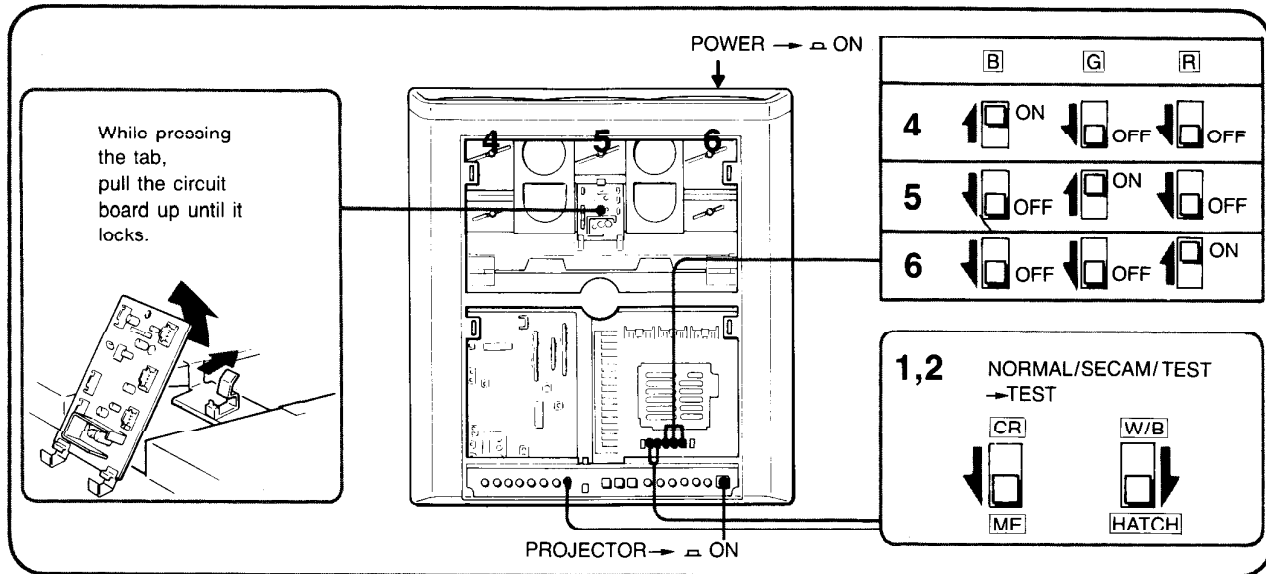

Preparations

- Install the projector in the correct position on the floor or ceiling.
- Connect the supplied power cord to the AC IN socket and to an AC outlet, depress the POWER switch on the connector panel and the PROJECTOR switch. The green POWER lamp will light.
- Open the top panel. (See page 11.)

Adjustment

- 1 Set the NORMAL/SECAM/TEST selector to TEST.
- 2 Set the HATCH/W/B switch to HATCH and CR/ME switch to ME (mesh). A cross hatch pattern will be displayed.
- 3 Check the following.

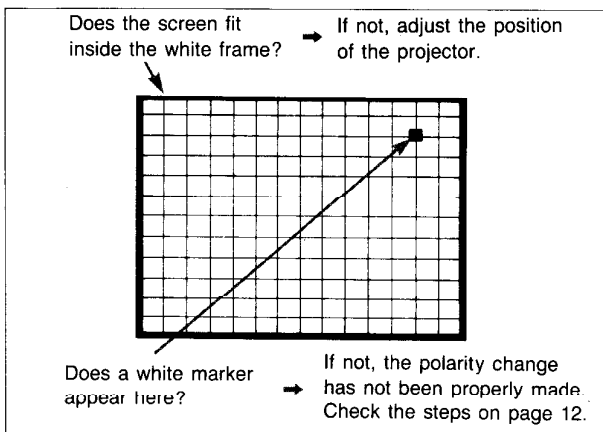

- 4 Set the G (green) and R (red) switches to OFF, then adjust the focus of the blue lens.

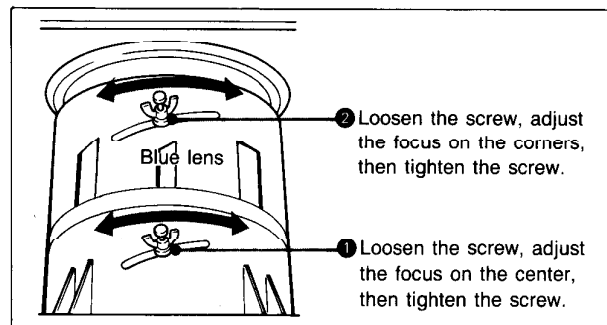

- 5 Set only the G switch to ON, and the R and B switches to OFF, then adjust the focus of the green lens.
- 6 Set only the R switch to ON, and the G and B switches to OFF, then adjust the focus of the red lens.
- 7 Replace the top panel. (Reverse the steps given on page 11.)

Proceed to registration adjustment.

Caution

Take care not to touch portions of the projector other than those indicated above because dangerous high voltages are present. To change the polarity, first turn the POWER switch off.

REGISTRATION ADJUSTMENT

Use a small screwdriver to adjust the controls through the holes.

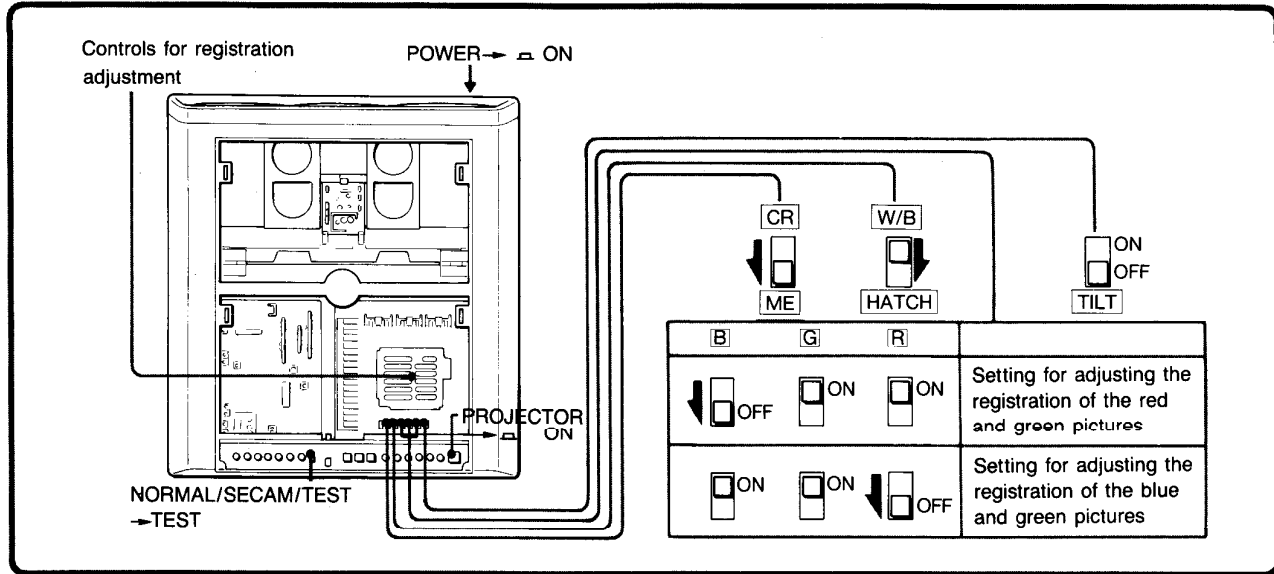

Controls for registration adjustment

These controls are used for the reference green picture readjustment. If readjustment is necessary, consult the qualified Sony personnel.

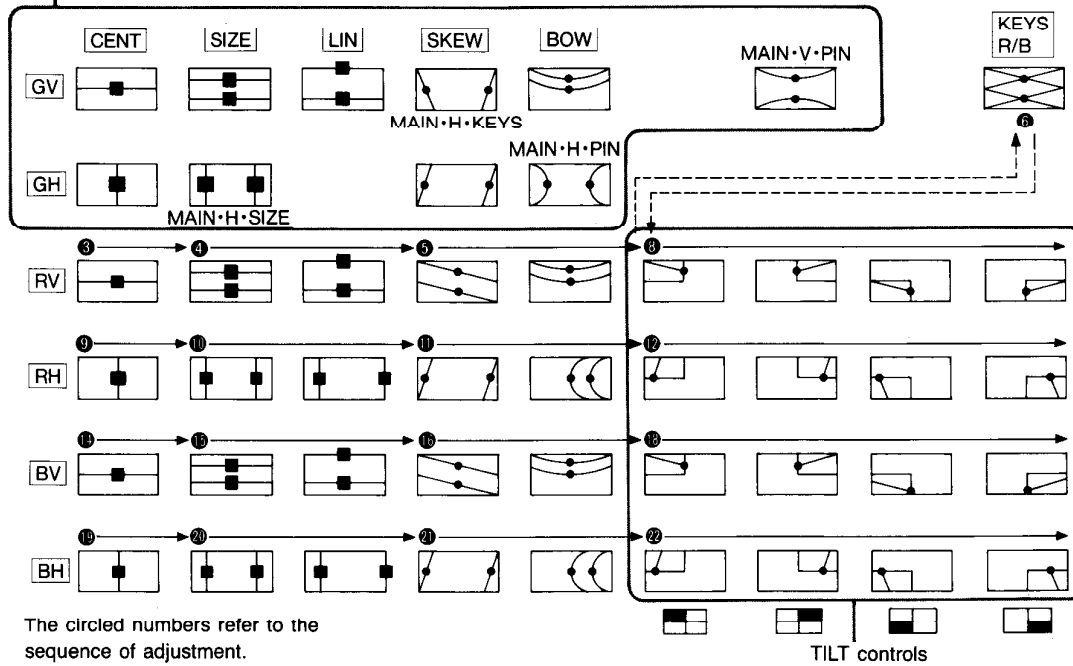

Preparations

- 1 Keep the G switch at ON and set the B and R switches to OFF. A green cross hatch pattern will be displayed.
- 2 Check the position of the projector, polarity and lens focus, referring to pages 12 and 13.

Vertical registration of the red and green pictures

- 1 Set the B switch to OFF and the G and R switches to ON.
- 2 Set the TILT switch to OFF (control panel side).
- 3 Adjust the RV CENT control so that the red horizontal lines and the green horizontal lines converge in the middle of the screen.
- 4 Adjust the RV SIZE control and RV LIN controls so that the red horizontal lines and the green horizontal lines converge at the upper and lower sides of the screen.

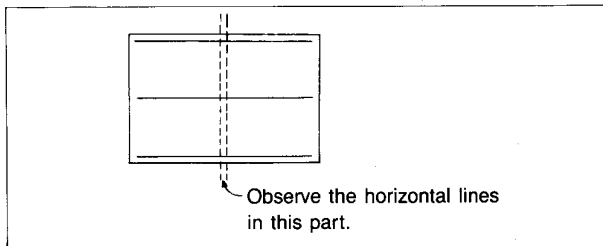

(Repeat steps 3 and 4 as necessary.)

- 5 Adjust the RV SKEW and RV BOW controls so that the red horizontal lines and the green horizontal lines converge in the middle of the screen.
- 6 Adjust the KEYS R/B control so that the red horizontal lines at the top and bottom of the screen are parallel.
- 7 Set the TILT switch to ON (lens side).
- 8 Adjust the RV TILT controls so that the red horizontal lines and the green horizontal lines converge in the corners of the screen.

Horizontal registration of the red and green pictures

- 9 Adjust the RH CENT control so that the red vertical lines and the green vertical lines converge in the middle of the screen.
- 10 Adjust the RH SIZE and RH LIN controls so that the red vertical lines and the green vertical lines converge at the right and left sides of the screen.

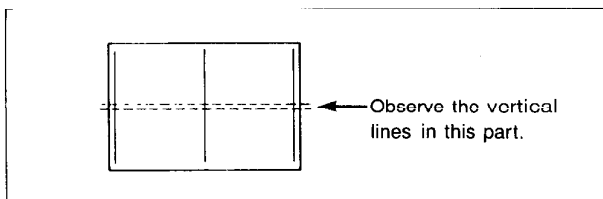

(Repeat steps 9 and 10 as necessary.)

- 11 Adjust the RH SKEW and RH BOW controls so that the red vertical lines and the green vertical lines converge in the middle of the screen.
- 12 Adjust the RH TILT controls so that the red vertical lines and the green vertical lines converge at the corners of the screen.

Proceed to the following adjustments in the same manner as with red and green registration, setting the R switch to OFF and the B and G switches to ON.

Vertical registration of the blue and green pictures

- 13 Set the TILT switch to OFF.
- 14 Adjust the BV CENT control.
- 15 Adjust the BV SIZE, and BV LIN if necessary. (Repeat steps 14 and 15 as necessary.)
- 16 Adjust the BV SKEW and BV BOW controls.
- 17 Set the TILT switch to ON.
- 18 Adjust the BV TILT controls.

Horizontal registration of the blue and green pictures

- 19 Adjust the BH CENT control.
- 20 Adjust the BH SIZE, and BH LIN. (Repeat steps 19 and 20 as necessary.)
- 21 Adjust the BH SKEW and BH BOW controls.
- 22 Adjust the BH TILT controls.

When registration is complete

Set the switches to the following positions

R, G, B switches	ON position
HATCH/W/B switch	HATCH
CR/ME switch	CR (cross)
TILT	ON position
NORMAL/SECAM/TEST	NORMAL

Replace the top panel. (Reverse the steps given on page 11.)

CONVERSION FOR 72" (67") or 200" (150"—250") PROJECTION

1 Separate the lens block from the main body.

- 1 Open the cabinet. (See page 11.)
- 2 Disconnect the 3 connectors on the K circuit board.
- 3 Loosen the 10 screws.

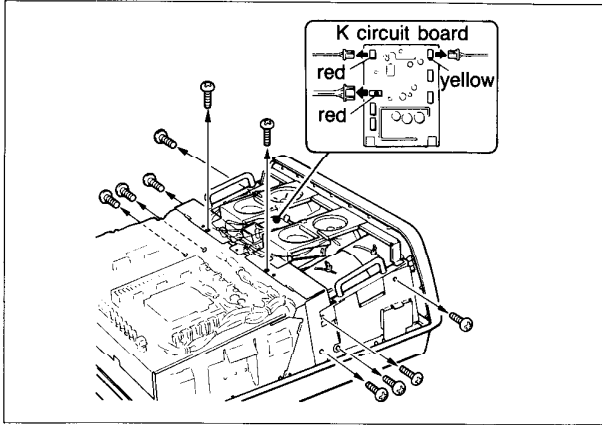

- 4 Pull the lens block up and out.

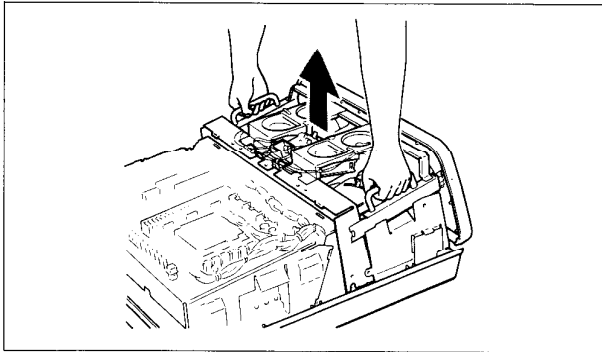

2 Disassemble the lens block.

- 1 Loosen the 4 screws.
- 2 Disconnect the 4 connectors on the K circuit board.
- 3 Pressing the tab, raise the K circuit board.

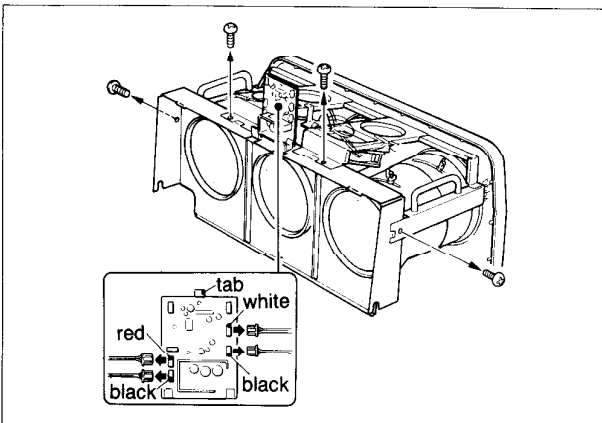

- 5 Remove the lens panel.

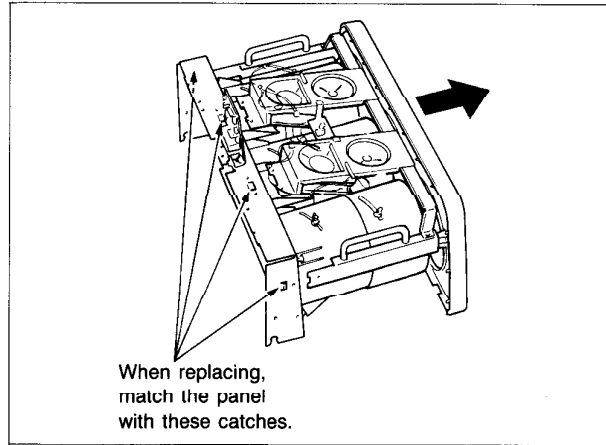

- 6 Loosen the 4 nuts and detach all lenses from the lens base.
Use an 8 mm nutdriver.

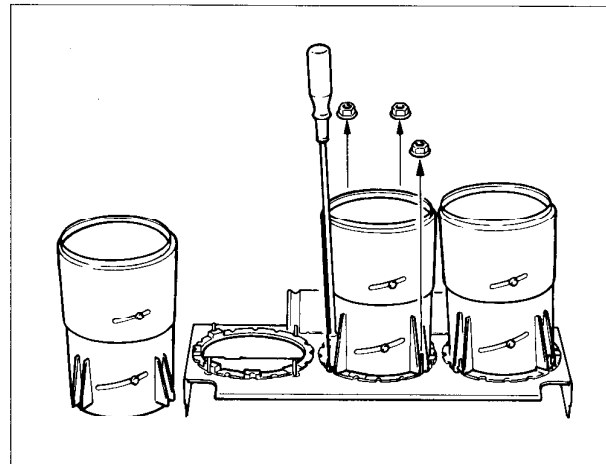

3 Change the positions of the lens rings.

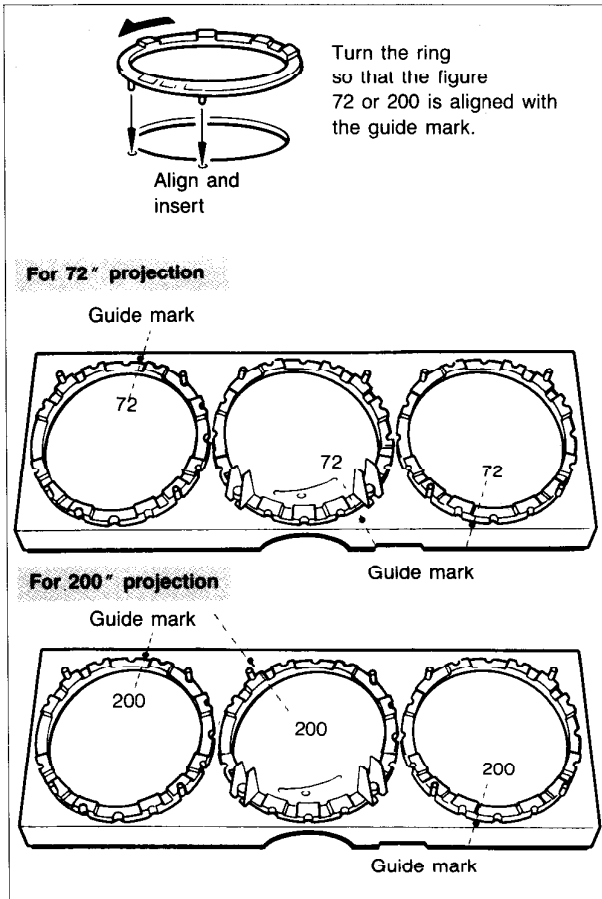

4 Adjust the mounting angles of the CRTs.

Use an 8 mm nutdriver.

- 1 Loosen the nuts and remove all the spacers from the top and bottom of each CRT.
- 2 Insert the supplied spacers as illustrated. Insert the spacers with the thinner end toward the center CRT.
- 3 Tighten all the nuts completely for accurate angles of the CRTs.

After adjustment is complete, replace the lens block in the main body and close the cabinet.
(Reverse the steps given in section 1.)

