

SONY

8-786-227-24(1)

Color Video Projector

VPH-1041Q/1041QM VPH-1042Q/1042QM

Operating Instructions Page 2

Before operating the unit, please read this manual thoroughly and retain it for future reference.

Installation and preliminary adjustments should be performed by qualified Sony personnel.

Mode d'emploi Page 24

Avant la mise en service de cet appareil, prière de lire attentivement le mode d'emploi qui vous sera remis pour toute référence ultérieure.

L'installation et les réglages préliminaires doivent être accomplis par un personnel Sony compétent.

Bedienungsanleitung Seite 44

Vor der Inbetriebnahme lesen Sie diese Anleitung sorgfältig durch und bewahren Sie sie zum späteren Nachschlagen auf.

Installation und Voreinstellungen sind von einem Sony Fachmann auszuführen.

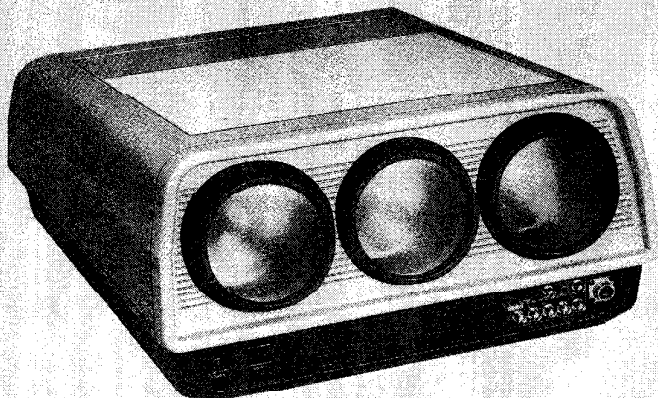

Super Bright

Contents

Warning	2
Precautions	4
Features	4
Location and function of controls	5

OPERATION

Position and registration adjustments	7
Projecting	8
Operation	8
Operation using the remote controller	8
Picture and sound adjustments	8

INSTALLATION AND CONNECTIONS

Installation diagrams	10
For 100" projection	10
For 72" projection	12
For 70" rear projection	14
For 100" - 250" projection	17
System connections	18
Without using the remote controller	18
Connecting a microcomputer	19
Using the remote controller	20
Specifications	21

Your projector is convertible for 70" to 250" projection. For conversion, please consult the qualified Sony personnel.

Owner's Record

The model and serial numbers are located at the right side. Record these numbers in the spaces provided below. Refer to them whenever you call upon your Sony dealer regarding this product.

Model No. _____ Serial No. _____

This manual covers the VPH-1041Q/1042Q (for USA and Canada) and the VPH-1041QM/1042QM (for European countries).

The operating procedures of all models are the same.

Warning

To prevent fire or shock hazard, do not expose the unit to rain or moisture.



CAUTION
RISK OF ELECTRIC SHOCK
DO NOT OPEN



CAUTION : TO REDUCE THE RISK OF ELECTRIC SHOCK,
DO NOT REMOVE COVER (OR BACK).
NO USER-SERVICEABLE PARTS INSIDE.
REFER SERVICING TO QUALIFIED SERVICE PERSONNEL.

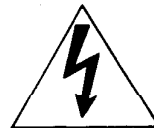

This symbol is intended to alert the user to the presence of uninsulated "dangerous voltage" within the product's enclosure that may be of sufficient magnitude to constitute a risk of electric shock to persons.



This symbol is intended to alert the user to the presence of important operating and maintenance (servicing) instructions in the literature accompanying the appliance.

Notice for the Customers in the USA

INFORMATION

This equipment generates and uses radio frequency energy and if not installed and used properly, that is, in strict accordance with the manufacturer's instructions, may cause interference to radio and television reception. It has been type tested and found to comply with the limits for a Class B computing device in accordance with the specifications in Subpart J of Part 15 of FCC Rules, which are designed to provide reasonable protection against such interference in a residential installation. However, there is no guarantee that interference will not occur in a particular installation. If this equipment does cause interference to radio or television reception, which can be determined by turning the equipment off and on, the user is encouraged to try to correct the interference by one or more of the following measures:

- Reorient the receiving antenna
- Relocate the equipment with respect to the receiver
- Move the equipment away from the receiver
- Plug the equipment into a different outlet so that equipment and receiver are on different branch circuits.

If necessary, the user should consult the dealer or an experienced radio/television technician for additional suggestions. The user may find the following booklet prepared by the Federal Communications Commission helpful:

"How to Identify and Resolve Radio-TV Interference Problems". This booklet is available from the U.S. Government Printing Office, Washington, DC 20402, Stock No. 004-000-00345-4.

The shielded interface cable recommended in this manual must be used with this equipment in order to comply with the limits for a computing device pursuant to Subpart J of Part 15 of FCC Rules.

Projection System Installation Instructions

WARNING: USE OF PROPER HARDWARE AND ACCESSORIES IS REQUIRED AS SPECIFIED. PROPER INSTALLATION ACCORDING TO INSTRUCTIONS IS REQUIRED. IMPROPER INSTALLATION MAY RESULT IN SERIOUS PERSONAL INJURY.

Notice for the Customers in the United Kingdom

WARNING THIS APPARATUS MUST BE EARTHED

IMPORTANT

The wires in this mains lead are coloured in accordance with the following code:

Green-and-yellow	: Earth
Blue	: Neutral
Brown	: Live

As the colours of the wires in the mains lead of this apparatus may not correspond with the coloured markings identifying the terminals in your plug proceed as follows: The wire which is coloured green-and-yellow must be connected to the terminal in the plug which is marked with the letter E or by the safety earth symbol \perp or coloured green or green-and-yellow. The wire which is coloured blue must be connected to the terminal which is marked with the letter N or coloured black. The wire which is coloured brown must be connected to the terminal which is marked with the letter L or coloured red.

Notice for the Customers in Canada

This apparatus complies with the Class B limits for radio noise emissions set out in Radio Interference Regulations of Canada.

Precautions

On safety

- Check that the operating voltage of your unit is identical with the voltage of your local power supply. If voltage adaptation is required, consult your Sony dealer or qualified personnel.
- Should any liquid or solid object fall into the cabinet, unplug the unit and have it checked by qualified personnel before operating it any further.
- Unplug the unit from the wall outlet or set the POWER switch to OFF if it is not to be used for several days.
- To disconnect the cord, pull it out by the plug. Never pull the cord itself.

On installation

- Allow adequate air circulation to prevent internal heat build-up. Do not place the unit on surfaces (rugs, blankets, etc.) or near materials (curtains, draperies) that may block the ventilation holes.
Be aware that room heat rises to the ceiling; check that temperature near the installation location is not excessive.
- Do not install the unit in a location near heat sources such as radiators or air ducts, or in a place subject to direct sunlight, excessive dust or humidity, mechanical vibration or shock.

On illumination

- To obtain a clear picture, the screen should not be exposed to illumination or sunlight directly from the front.
- Ceiling mounted spot lighting is recommended. Use a construction over light-scattering illumination such as fluorescent lamps.
- Cover the windows that face the screen with opaque draperies.
- It is desirable to install the projector in a room whose floor and walls are not of light-reflecting material.
If the floor and walls are of reflecting material, it would be desirable to change to a dark carpet and wall paper.

On cleaning

- To keep the cabinet looking brand-new, periodically clean it with a soft cloth. Stubborn stains may be removed with a cloth lightly dampened with a mild detergent solution.
Never use strong solvents, such as thinner or benzene, or abrasive cleansers, since these will damage the cabinet.
- Avoid touching the lens. To remove dust on the lens, use a soft dry cloth. Do not use a damp cloth, detergent solution, or thinner.

On repacking

Save the original shipping carton and packing material; they will come in handy if you ever have to ship your unit. For maximum protection, repack your unit as it was originally packed at the factory.

Features

Bright image—light output 600 lumen

A newly-developed phosphor and electron gun and the high voltage circuit provide a high-quality image with extra sharpness and brightness.

Newly-developed Sony HACC (High-resolution Aspherical and Color Corrected) lens (VPH-1042Q/1042QM only)

The HACC lens highly contributes to sharpness and contrast improvement.

Fine-detailed picture—resolution 1000 lines

High contrast and sharp picture with a resolution of 1000 lines is obtained by the combined use of an electron gun providing a sharp picture, a colored coolant filter providing efficient color reproduction, a double focus lens system providing accurate focus even in the corners of the screen as well as the center, and anti-reflection coating to improve focus and contrast in the corners.

S VIDEO input connector

This unit is equipped with an S VIDEO input connector through which Y (luminance) and C (chrominance) signals can be input separately. This reduces interference between the signals and ensures excellent picture quality.

TO VPR-722S connector

The TO VPR-722S connector allows connection of the optional VPR-722S remote controller with a single cable.

Sync on green

For RGB signals, if a sync signal is input through the green input together with the green signal, this sync signal is used to control the picture.

If, however, a sync signal is input through the SYNC/HD connector or the SYNC/HD and VD connectors, this sync signal is used even when there is a sync signal on the green signal.

Four color systems available

PAL, SECAM, NTSC or NTSC4.43* color system is selected automatically.

Various installation possibilities

The projector is designed to be installed on desk, floor or ceiling and can be used with a flat screen, curved screen or rear projection screen.

Illuminated control panel

When the panel cover is open, the control panel where the user controls are located is illuminated for easy operation in dim or dark places.

Internal test signal

Adjustments can be performed easily by projecting the built-in cross-hair test signal. No external test signal is needed.

* A signal of NTSC4.43 system is obtained by playing back NTSC-recorded video tapes with a video tape recorder/player specially designed for use with this system.

Location and Function of Controls

For details on the use of each control, refer to the pages in ●.

Control panel

RGB BLUE MODE SELECT switch ⑧

RGB H SHIFT (horizontal shift) control ⑨

V HOLD (vertical hold) control ⑨

NORM/TEST (normal/test signal) selector ⑦ ⑧

V CENT (vertical centering) controls ⑦

H CENT (horizontal centering) controls ⑦

INPUT SELECT buttons ⑧

Press to select the program source to be projected.

LINE: For inputs from the TO-VPR-722S connector or the LINE S VIDEO or VIDEO connector

RGB: For inputs from the RGB IN connectors

HUE control ⑨

COLOR control ⑨

SHARPNESS control ⑨

BRIGHT (brightness) control ⑨

PICTURE control ⑨

Open the panel cover.
The control panel is illuminated when the panel cover is open.

PROJECTOR switch ⑦ ⑧

VOLUME control ⑨

POWER lamp

COLOR SYSTEM selector

Normally set to AUTO.

Set to SECAM when the color of a picture from SECAM color sources is disturbed.

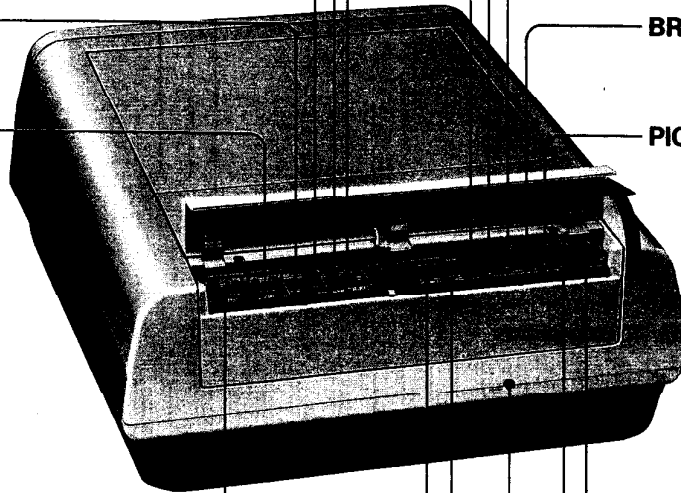

Location and Function of Controls

Connector panel

Blue lens

Green lens

Red lens

POWER switch 7 8

Depress to turn the power on.
When the remote controller is connected,
power will be supplied to the controller.

AC IN socket

Speaker

RGB IN connectors (BNC)

R, G/G SYNC, B, SYNC/HD, VD connectors

LINE IN (line input) connectors

S VIDEO (4-pin, mini DIN)

VIDEO (BNC)

AUDIO (phono)

Note

The VIDEO connector is disconnected automatically when a cable is connected to the S VIDEO connector.

MONITOR OUT (monitor output) connector (BNC)

The signal input to the TO VPR-722S, S VIDEO or VIDEO input connector is output from this connector.*

If signals are connected to each connector, the output signal is selected according to the following priority: TO VPR-722S, S VIDEO and VIDEO.

TO VPR-722S connector (14-pin, male)

* The separated Y (luminance) and C (chrominance) signals input to the S VIDEO connector is output as composite video signal.

Bottom

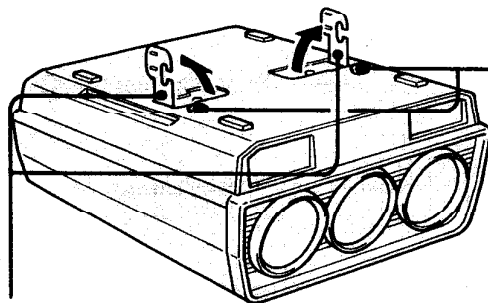

Brackets

For attaching the projector to the PSS-722 suspension support or the SU-722 pedestal.

Adjustable feet

The horizontal balance and angle of the projector can be adjusted with these feet.

The feet are factory-adjusted to the shortest length for a flat base.

Turn either foot to obtain horizontal balance.

Turn both feet to adjust the angle.

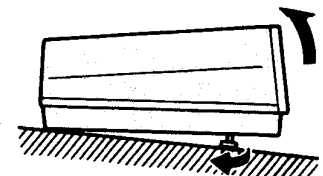
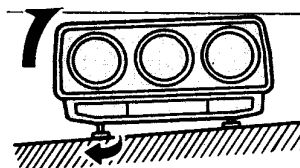

Position and Registration Adjustments

Installation and preliminary adjustments should be carried out by qualified Sony personnel.

When the projector is installed on a desk or on the floor using the pedestal, it can be easily moved but it may be necessary to readjust the registration.

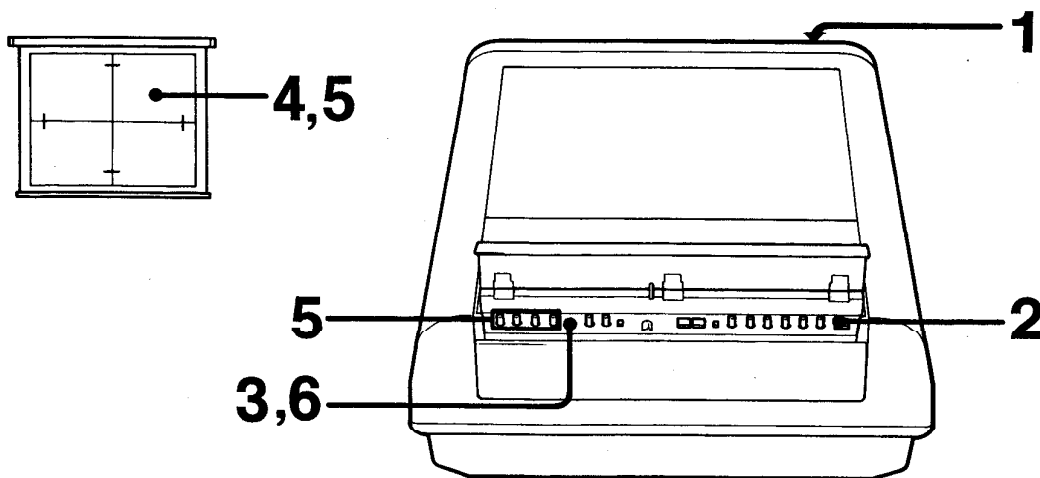

1 Depress the POWER switch (ON).

2 Depress the PROJECTOR switch (ON).

3 Set the NORM/TEST selector to TEST.
The built-in cross-hair test pattern will be displayed.

4 Check the focus and centering.
If the test pattern is not centered and focused on the screen, move the projector slightly so that the pattern is displayed clearly.

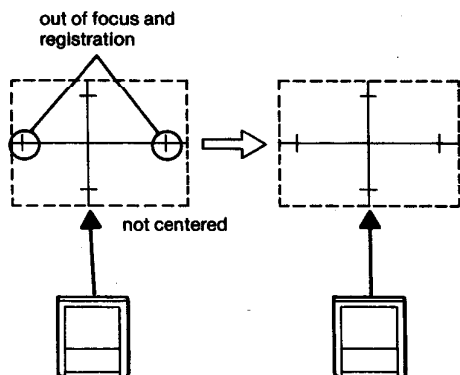

5 Check the convergence of red, green and blue.
If the red and blue lines do not converge with the green line, adjust the H CENT and V CENT controls so that the three lines converge and the pattern is seen as white.

To move the red and blue vertical lines

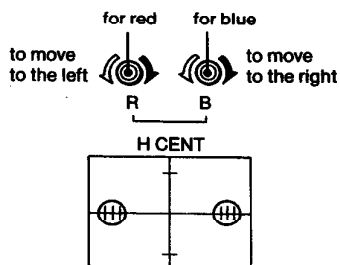

To move the red and blue horizontal lines

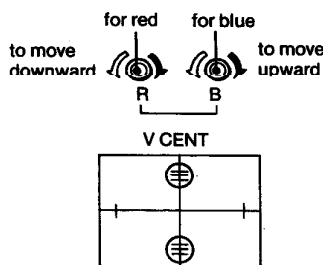

6 After the adjustment is complete, set the NORM/TEST selector to NORM.

For the appropriate distance between the projector and the screen, see pages 10 to 17.

Projecting

Operation

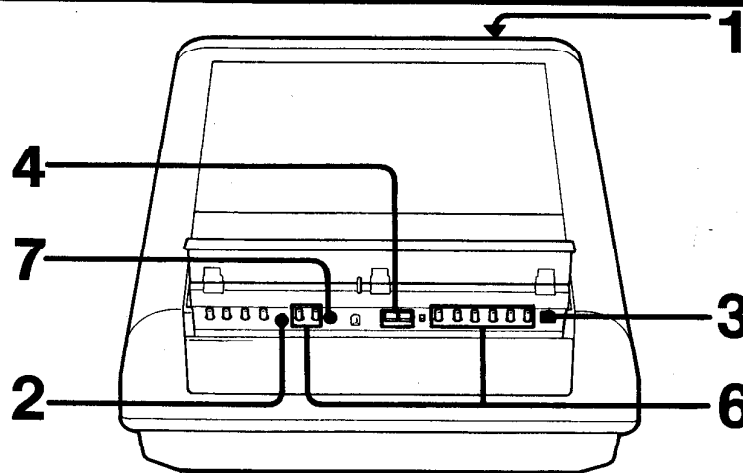

- 1** Depress the POWER switch (ON).
- 2** Make sure that the NORM/TEST selector is set to NORM.
- 3** Depress the PROJECTOR switch (ON).
The green POWER lamp will light.
- 4** Select the program to be projected by pressing the LINE or RGB INPUT SELECT button.
- 5** Turn on the connected equipment.
The picture will be projected on the screen and the sound will be heard from the speaker.
- 6** Adjust the picture and sound to your preference.
See below.

- 7** For RGB programs, select the position of the RGB BLUE MODE SELECT switch.
See "RGB BLUE MODE SELECT switch".

To turn off the projector
Press the PROJECTOR switch again (OFF).

To turn off the power
Press the POWER switch (OFF).

RGB BLUE MODE SELECT switch

This switch is effective only for RGB inputs. Select the position in which the display is easiest to view.

NORMAL	Normally set to this position.
BB	To change the black background to blue.
CB	To lighten the blue part of the display.

Operation Using the Remote Controller

When the optional Sony VPR-722S remote controller is connected to the TO VPR-722S connector, keep the POWER switch on the projector at ON and perform steps 3, 4, 6 and 7 above on the controller. The controls on the projector do not function.

Note

V HOLD and H SHIFT adjustments cannot be operated with the controller.

Picture and Sound Adjustments

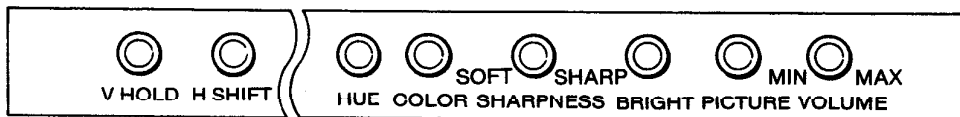

VOLUME	Turn toward MAX to increase volume, and toward MIN to decrease it.
PICTURE	Turn clockwise to increase picture contrast, color intensity and brightness in the proper ratio, and counterclockwise to decrease them.
BRIGHT	Turn clockwise for more brightness, and counterclockwise for less.
SHARPNESS	Turn clockwise for sharp picture, and counterclockwise for soft.
COLOR	Turn clockwise for more color intensity, and counterclockwise for less.

HUE	(Effective only for a program of the NTSC or NTSC _{4.43} color system) Turn clockwise to make the skin tones greenish, and counterclockwise to make them purplish.
RGB H SHIFT	(Effective only for RGB inputs) Turn to adjust the horizontal position of the picture.
V HOLD	If the picture rolls vertically, turn until the picture stabilizes.

Installation Diagrams

100"

For the same type of installation in another place, no readjustment is required, although the projector should be placed in the proper position.
 The projector is preadjusted at the factory for 100" projection, and internal conversion is necessary for other projection sizes. For internal conversion, consult the qualified Sony personnel.

For 100" Projection

Desk

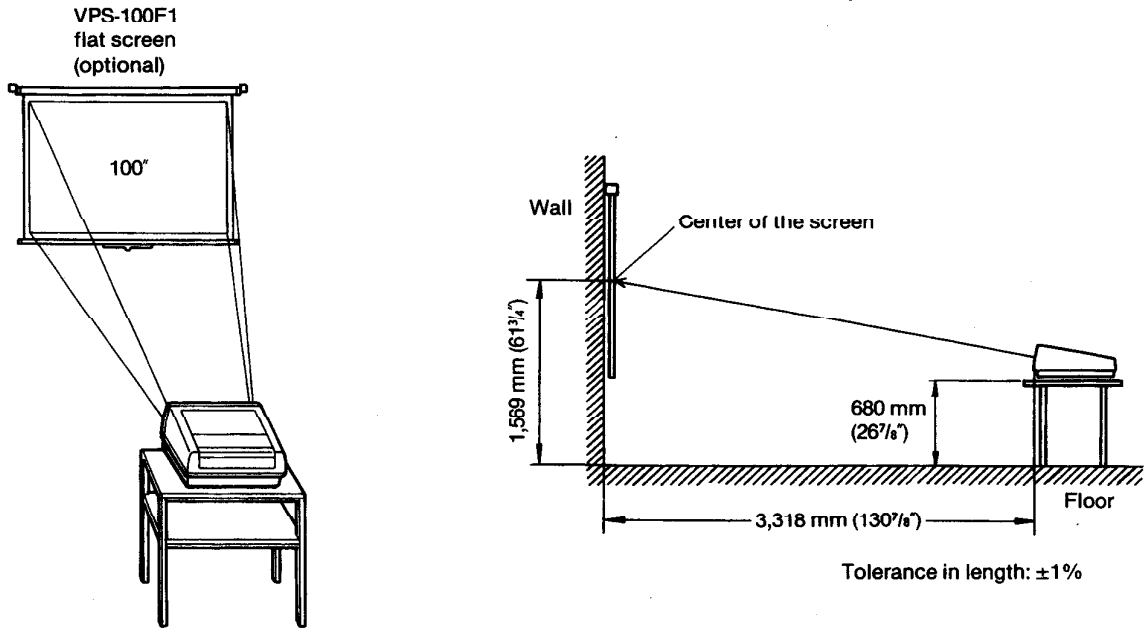

Floor

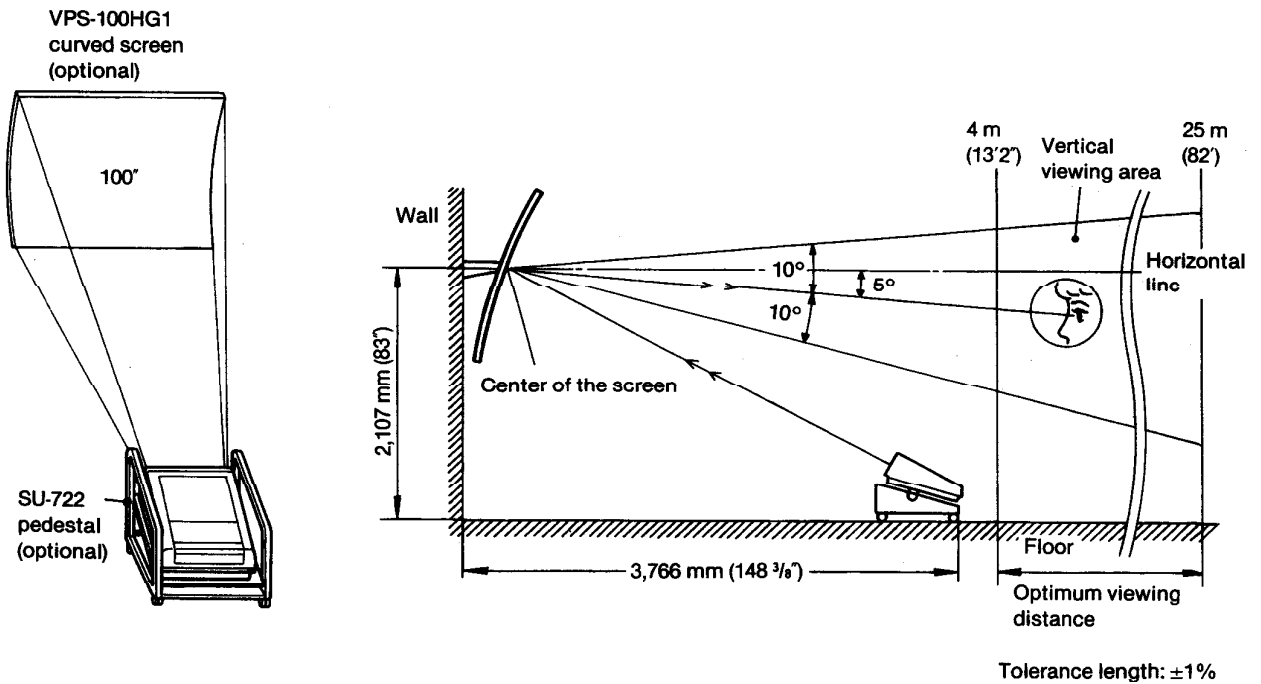

Ceiling

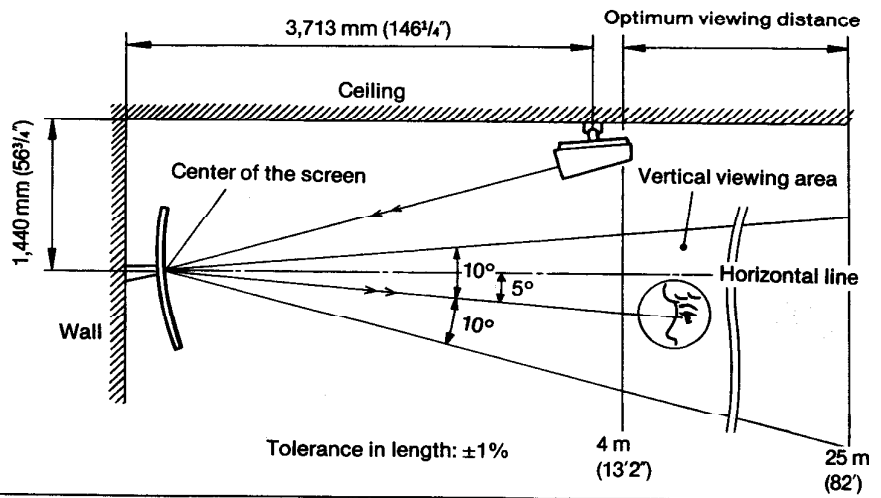
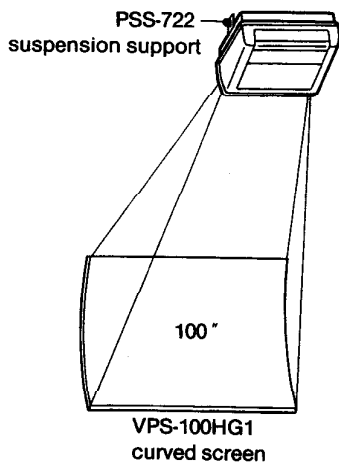
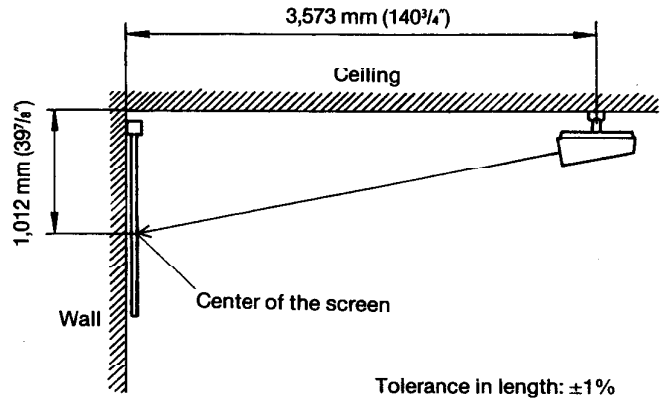
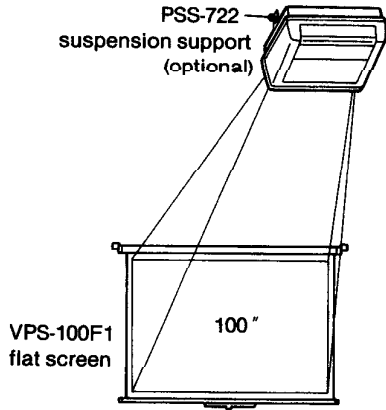

Horizontal viewing area for the VPS-100HG1

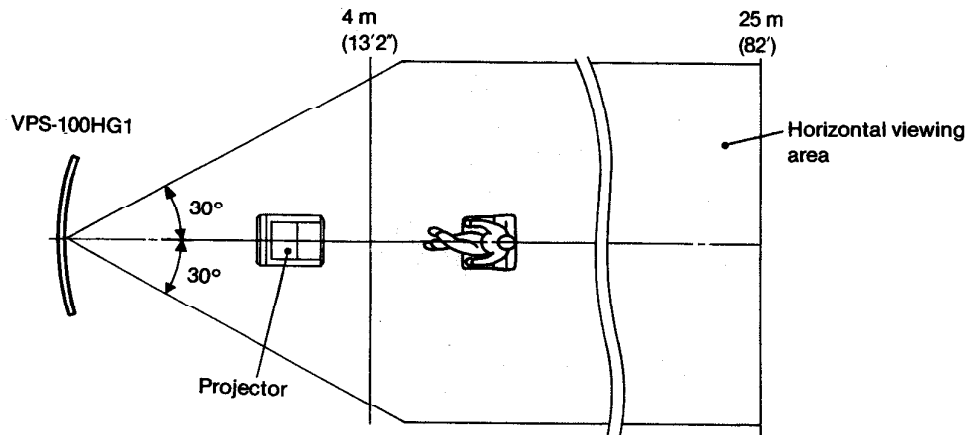

For 72" Projection

Desk

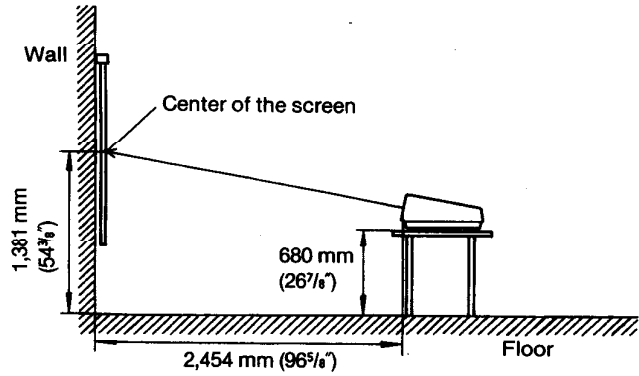
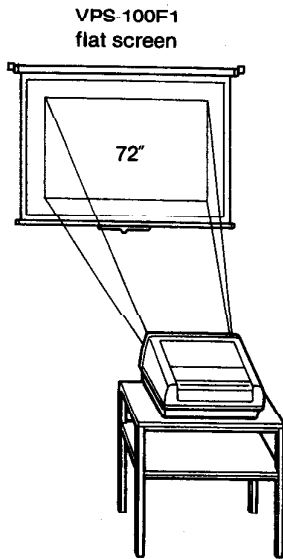

Tolerance in length: $\pm 1\%$

Floor

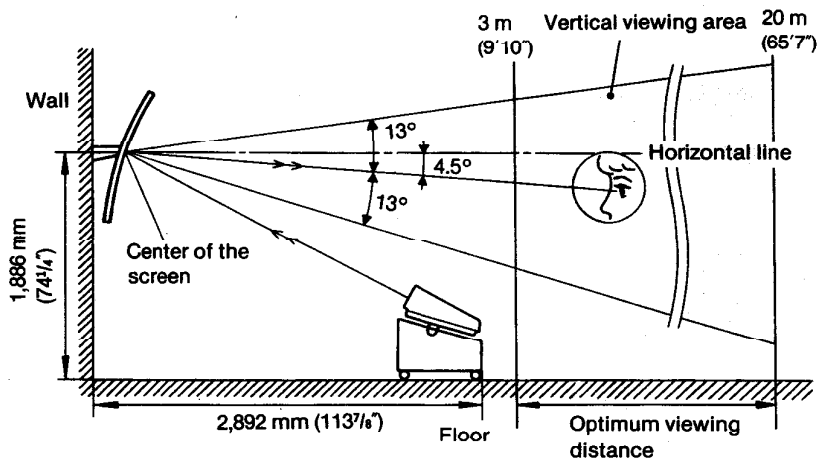
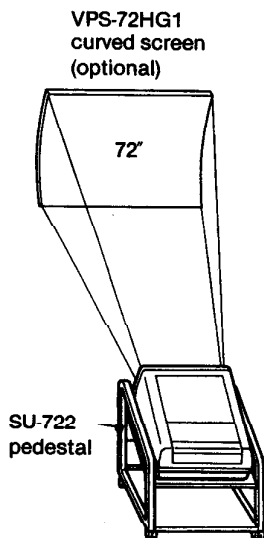

Tolerance in length: $\pm 1\%$

Ceiling

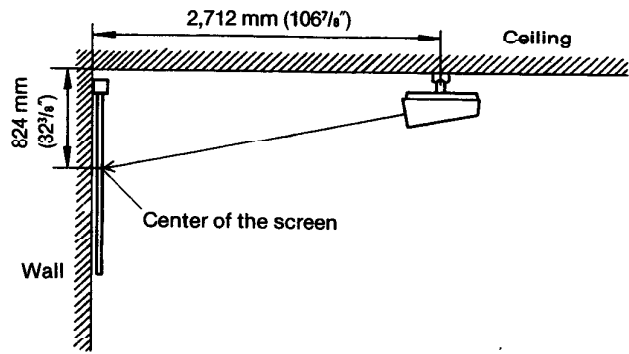
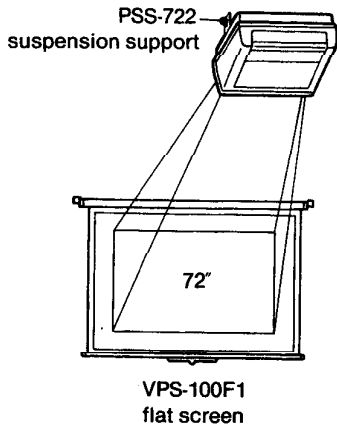

Tolerance in length: $\pm 1\%$

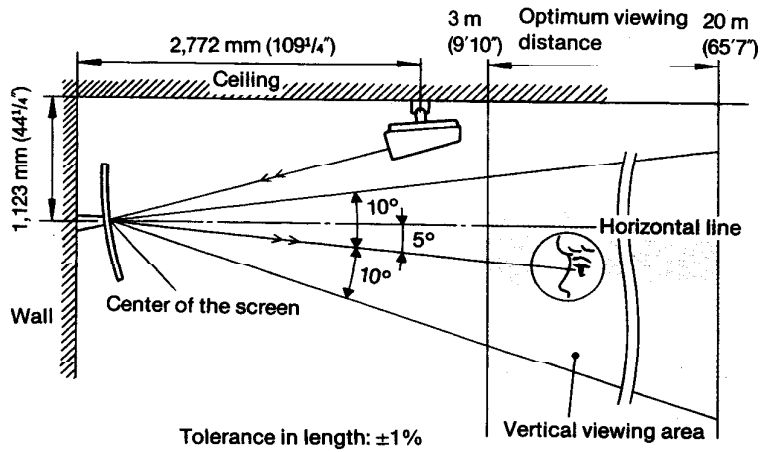
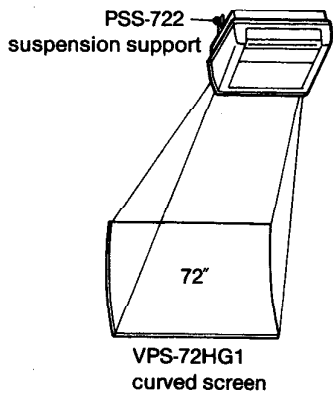

Tolerance in length: $\pm 1\%$

Horizontal viewing area for the VPS-72HG1

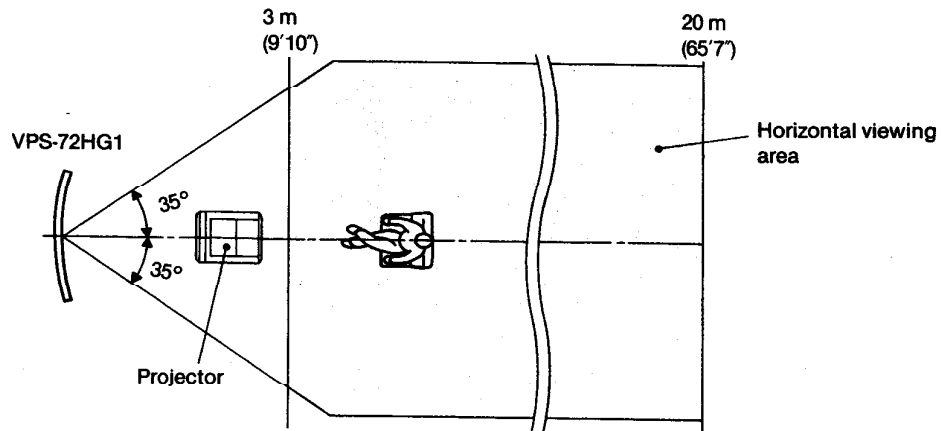

For 70" Rear Projection

Desk

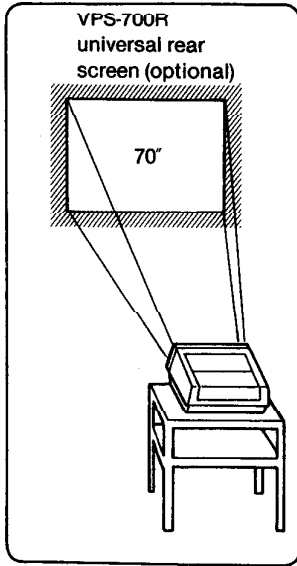

The viewing area is set upwards.

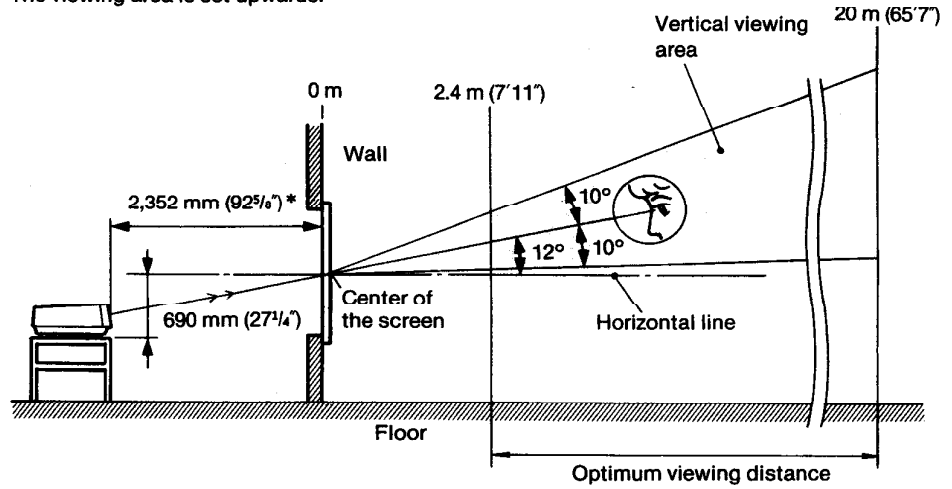

* Distance between the rear of the screen and the center of the G lens.

Tolerance in length: $\pm 1\%$

Ceiling

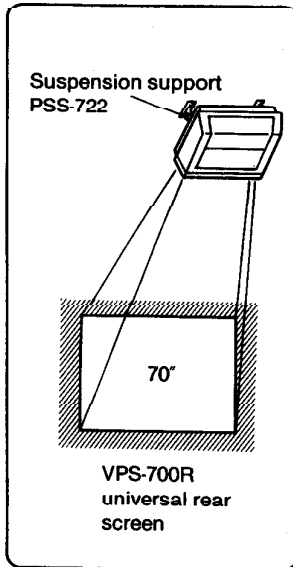

The viewing area is set downwards.

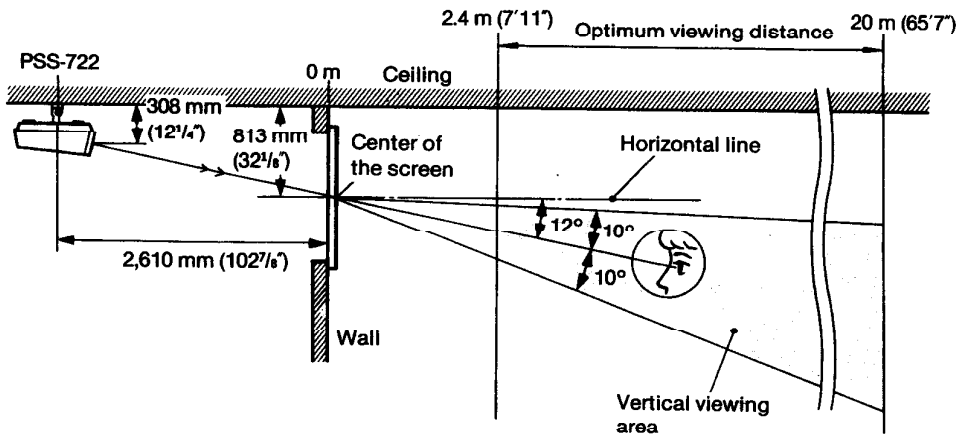

Tolerance in length: $\pm 1\%$

Level Projection

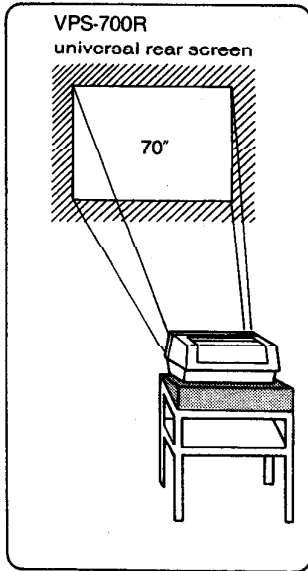

The viewing area is set approximately direct (approx. 1° upward).

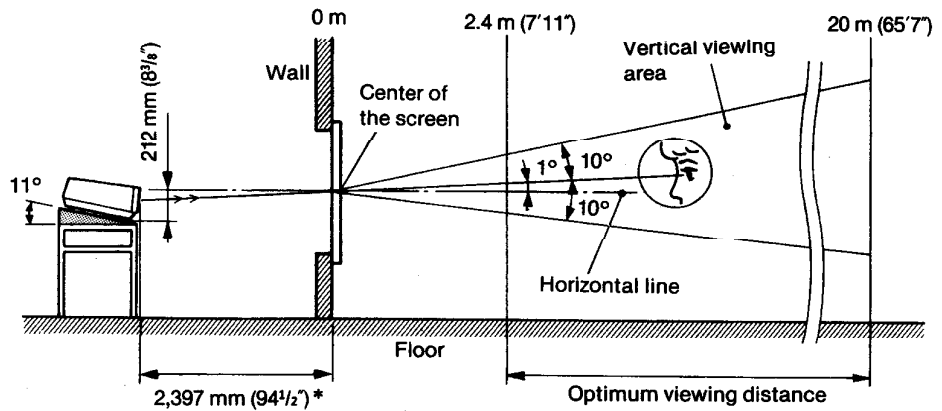

* Distance between the rear of the screen and the center of the G lens.

Tolerance in length: ±1%

Upturned Level Projection

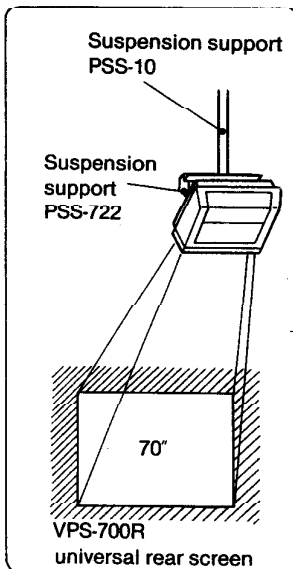

The viewing area is set approximately direct (approx. 1° downward).

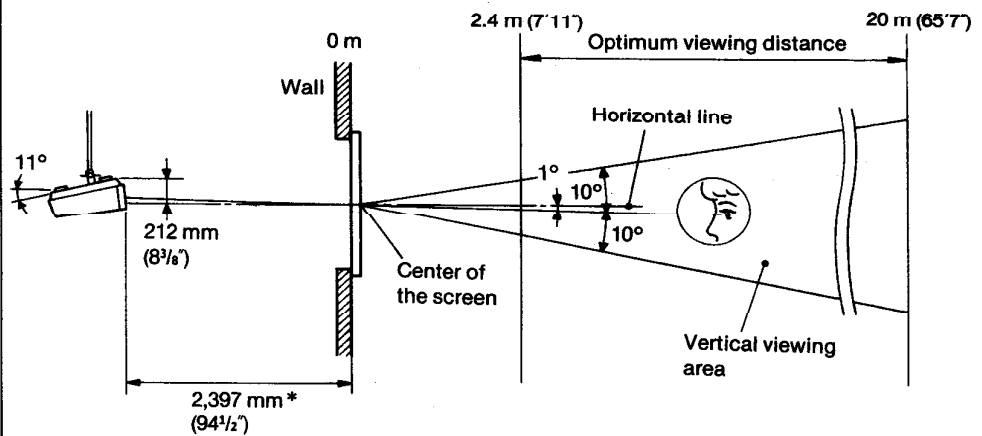

* Distance between the rear of the screen and the center of the G lens.

Tolerance in length: ±1%

Horizontal viewing area for the VPS-700R

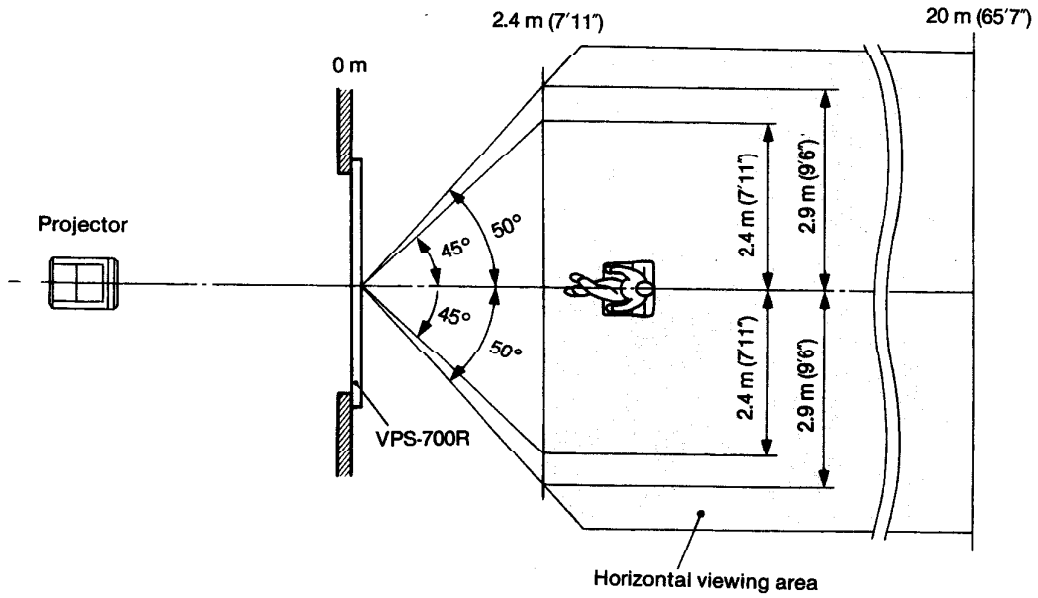

To adjust the distance between the ceiling and the projector, use the optional PSS-10 projector suspension support in combination with the PSS-722.

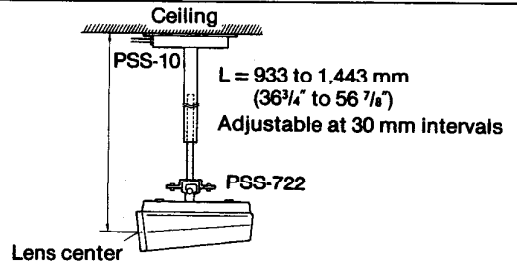

100"–250"

For 100"–250" Projection

Decide the length and height according to the size of the screen to be used.
For a screen not described in the tables, set the length approximately 1.6 times screen width.

Floor

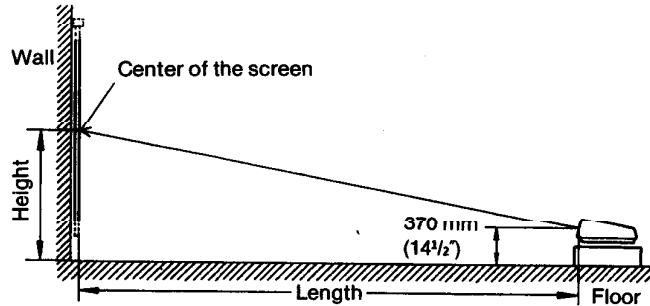
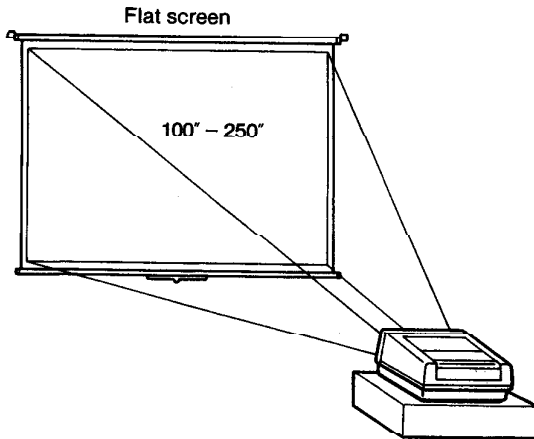

Screen size	150 inches	200 inches	250 inches
Length mm	4850 (191')	6410 (252 1/2')	7960 (313 1/2')
Height mm	1410 (55 1/2')	1740 (68 1/2')	2080 (82')

Tolerance in length: $\pm 1\%$

Ceiling

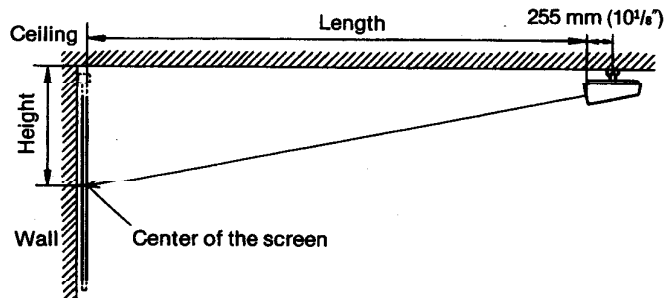
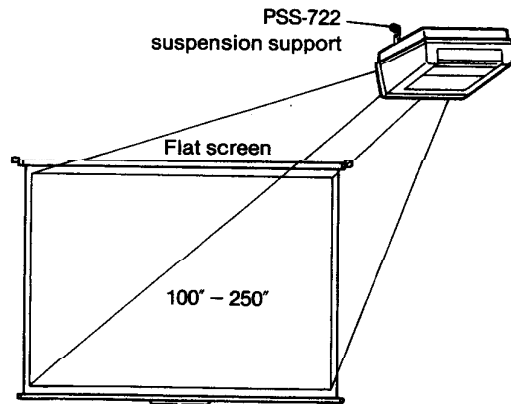

Screen size	150 inches	200 inches	250 inches
Length mm	4850 (191')	6410 (252 1/2')	7960 (313 1/2')
Height mm	1350 (53 1/4')	1680 (66 1/4')	2020 (79 1/2')

Tolerance in length: $\pm 1\%$

To use 150" to 250" screens, the projector should be converted for 200" projection. For conversion, consult the qualified Sony personnel.

To transport the projector, use the VLC-1040 carrying case (optional).



System Connections

Connecting Notes

- First make sure that the power to each piece of equipment is turned off.
- The cable connectors should be fully inserted into the jacks. A loose connection may cause hum and noise.
- To disconnect the cable, pull it out by grasping the plug. Never pull the cable itself.
- Use suitable connecting cables according to the equipment to be connected.
- For connection to the VIDEO IN and TO VPR-722S connectors, the connecting cable may be extended to max. 50 m (164 feet ½ inch). If the connecting cable is longer than 50 m, picture quality may be impaired somewhat.
- Read the instruction manual of the equipment to be connected.

Without Using the Remote Controller

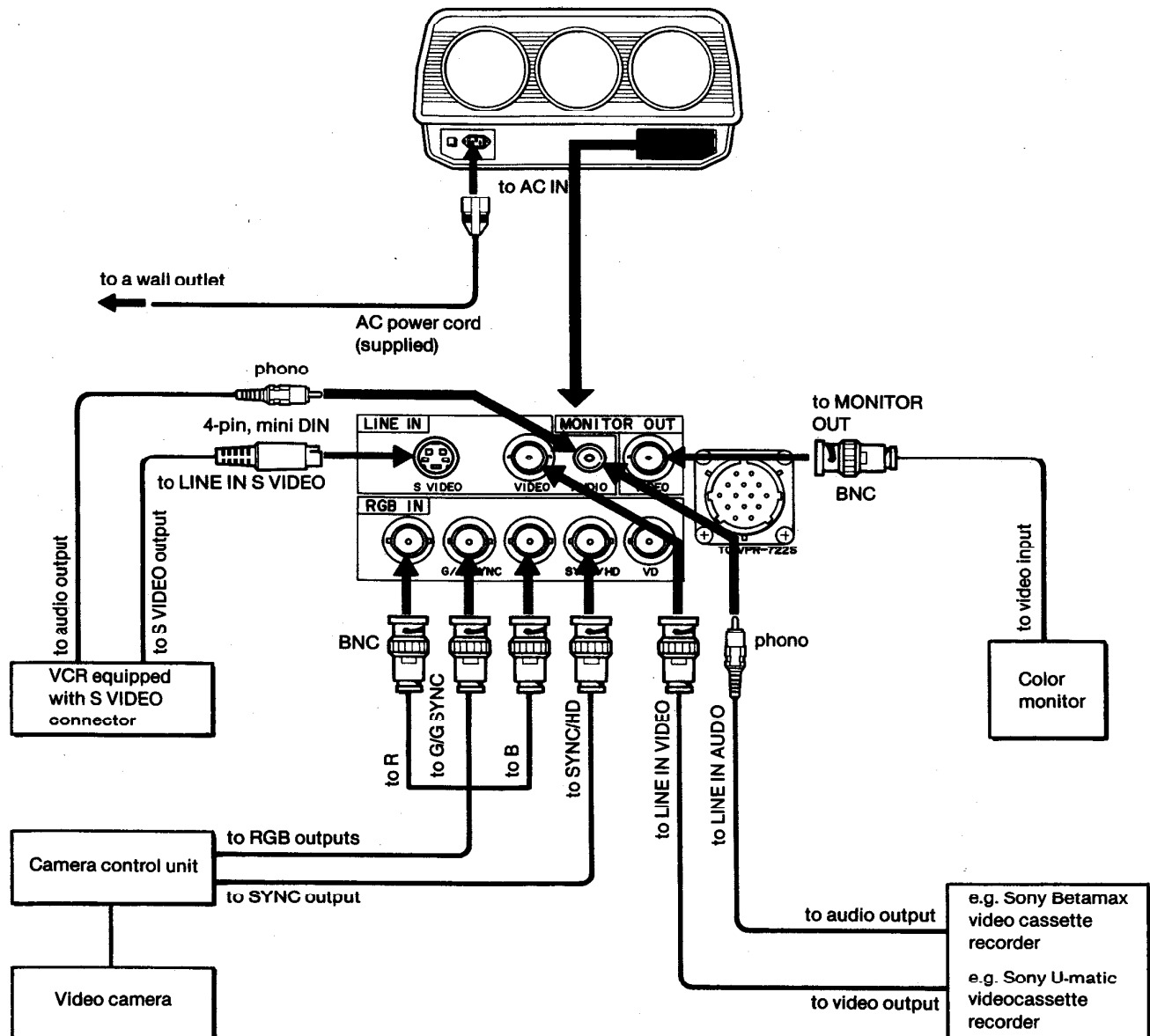

Connecting a Microcomputer

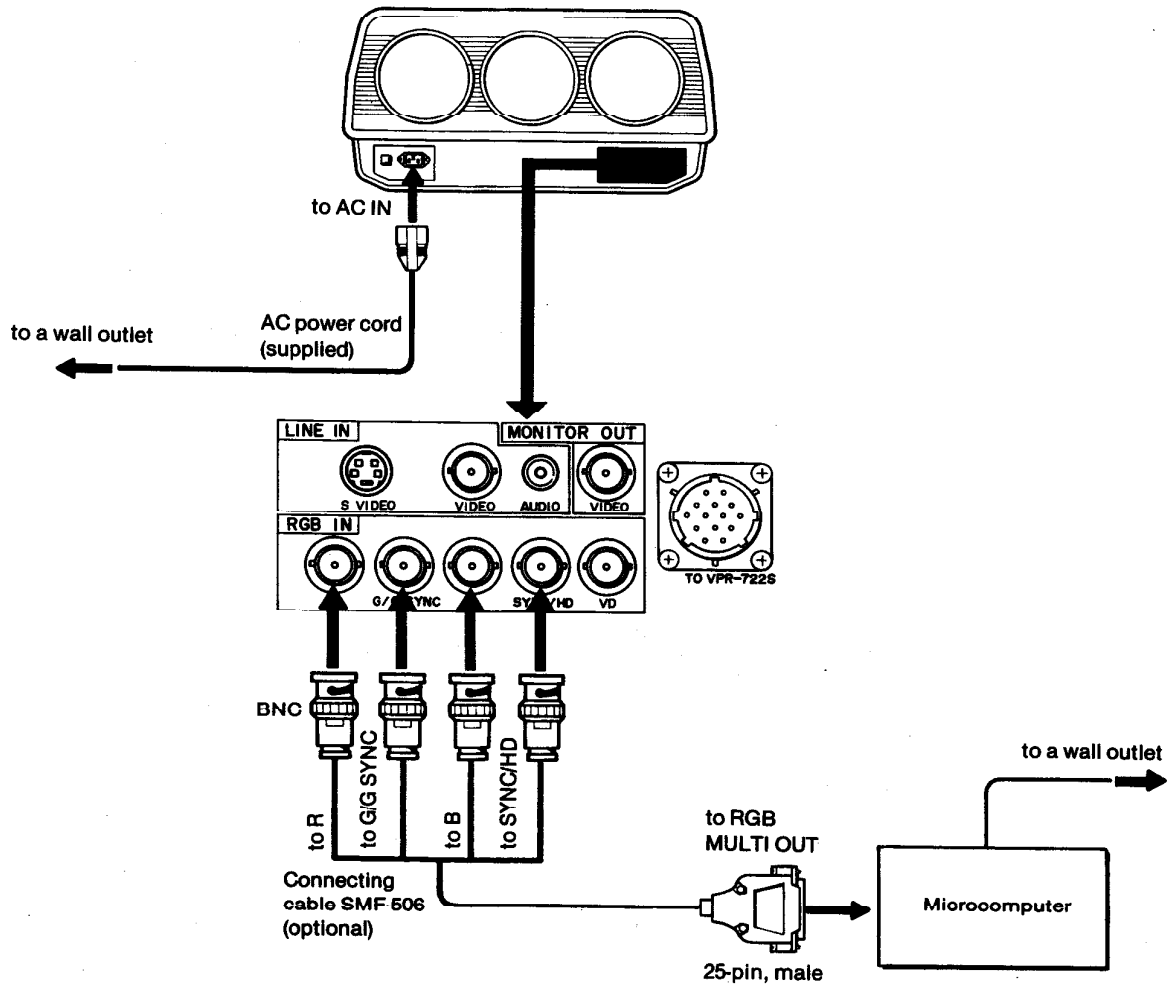

Sync Signal Connection for RGB Inputs

The connection differs according to the sync signal to be used.

When a sync signal is input together with the green signal	Connection to the SYNC/HD and VD connectors is not necessary.
When using an external composite sync signal	Connect it to the SYNC/HD connector. (as illustrated above)
When using horizontal and vertical sync signals	Connect them to the SYNC/HD and VD connectors respectively.

- If your microcomputer is equipped with a composite video output, connect it to the LINE IN VIDEO connector on the projector.

Note

Do not leave a still picture from a microcomputer or video disc player projected for more than one hour.

BNC connector

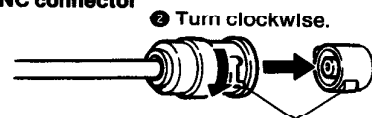

➊ Align and insert.

System Connections

Using the Remote Controller

Use the optional VPR-722S remote controller when the projector is installed on the ceiling or when you want to operate the projector at a distance from your seat.

Remote Controllable Operations

- Power on/off
- Program selection (LINE or RGB)
- Picture and sound adjustments
- RGB blue mode selection

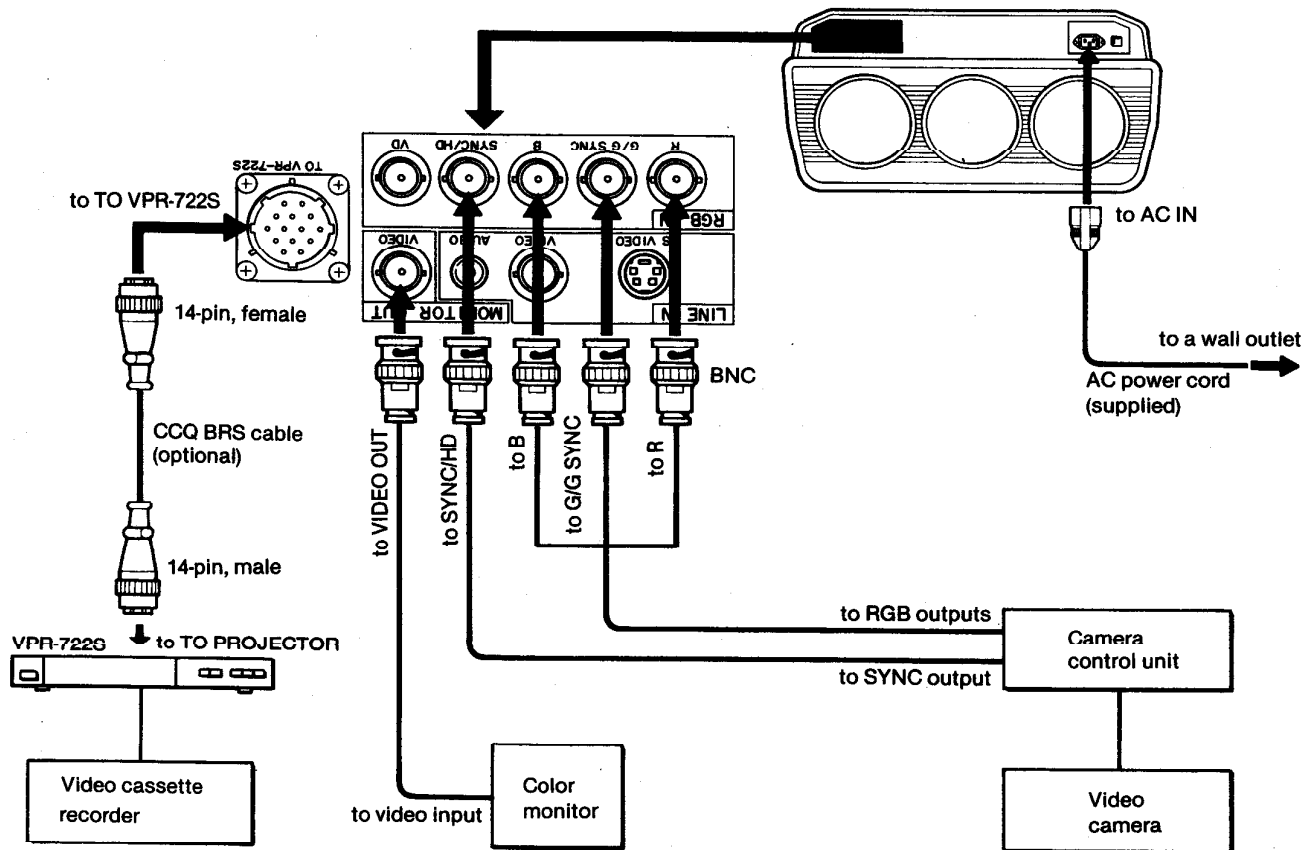

Notes

When the remote controller is connected to the TO VPR-722S connector:

- the LINE IN S VIDEO, VIDEO and AUDIO connectors are disconnected automatically.
- the PROJECTOR switch, INPUT SELECT buttons, RGB BLUE MODE SELECT switch and the controls for picture and sound adjustments (except H SHIFT and V HOLD) do not function.

14-pin connector

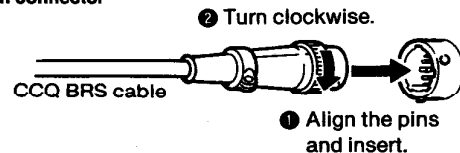

Specifications

Optical

- Projection system** 3 picture tubes, 3 lenses, direct projection system
- Picture tube** 5.5-inch high-brightness monochrome tubes, with coolant sealed
- Projection lens** VPH 1041Q/1041QM:
High-performance hybrid lenses
F1.0/130 mm
VPH-1042Q/1042QM:
HACC (High Resolution Aspherical and Color Corrected) lenses
F1.0/135 mm
- Projected picture size** 70 – 250 inches measure diagonally
Factory-adjusted to 100 inches measured diagonally
- Light output** 600 lm

General

- Color system** PAL, SECAM, NTSC and NTSC4.43 systems, switched automatically
- Resolution** 1,000 TV lines (RGB inputs)
650 TV lines (video input)
- RGB inputs** Character display capacity:
2000 character
(80 letters x 25 lines)
Horizontal frequency: 15.75 kHz
Vertical frequency: 50/60 Hz
- Test signal** Cross-hair test pattern generator is incorporated.
- Speaker** 5 x 9 cm (2 x 3 1/2 inches) 1 unit, 3 W
- Inputs**

LINE IN

- S VIDEO:** 4-pin mini DIN connector
Y (luminance) signal: 1 Vp-p ±2 dB, sync negative, 75 ohms terminated
C (chrominance) signal: burst
0.286 Vp-p ±2dB, 75 ohms terminated (NTSC)
0.3 Vp-p ±2dB, 75 ohms terminated (PAL)

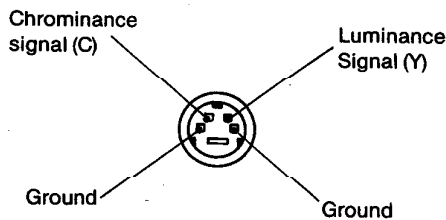

- VIDEO:** BNC connector
Composite video input,
1 Vp-p ±2 dB, sync negative,
75 ohms terminated
- AUDIO:** phono jack
VPH-1041Q/1042Q:
-5 dBs
Impedance: more than 47 k ohms
VPH-1041QM/1042QM:
0.5 Vrms
Impedance: more than 47 k ohms

RGB IN

- R:** BNC connector
Red input, 0.7 Vp-p ±2 dB,
75 ohms terminated, positive
- G/G SYNC:** BNC connector
Green input, 0.7 Vp-p ±2 dB,
75 ohms terminated, positive
Green with sync input,
1 Vp-p ±2 dB, 75 ohms terminated, positive
- B:** BNC connector
Blue input, 0.7 Vp-p ±2 dB,
75 ohms terminated, positive
- SYNC/HD:** BNC connector
Composite sync input,
0.3 – 4 Vp-p,
75 ohms terminated, negative
Horizontal sync input,
0.3 – 4 Vp-p,
75 ohms terminated, negative
- VD:** BNC connector
Vertical sync input, 0.3 – 4 Vp-p,
75 ohms terminated, negative

Output

MONITOR OUT

- VIDEO:** BNC connector
Composite video output,
1 Vp-p ±2 dB, impedance
75 ohms, selected video output
With the remote controller:
video signal from the controller*
Without the remote controller:
video signal from the LINE IN connector*
- * The separated Y and C signals input to the S VIDEO connector is output as a composite video signal.

TO VPR-722S connector

14-pin connector

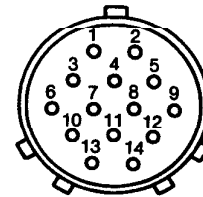

Pin No.	Signal	Pin No.	Signal
1	Ground	8	Input select
2	+28V $\overline{\text{---}}$ 60mA	9	Audio (incl. volume control)
3	Hue 1	10	Brightness
4	Hue 2	11	Sharpness or chrominance signal
5	Hue 3	12	Color
6	Video or luminance signal	13	Picture
7	Ground (video)	14	Power ON: 12 V OFF: 0 V

Specifications

Power requirements

VPH-1041Q/1042Q: 120 V AC, 50/60 Hz
VPH-1041QM/1042QM: 220 – 240 V AC, 50/60 Hz

Power consumption

VPH-1041Q/1042Q: 230 W max., 3.0 A max.
VPH-1041QM/1042QM: 210 W

Dimensions

Approx. 532 × 288 × 597 mm (w/h/d)
(21 × 11³/₈ × 23⁵/₈ inches)

With the brackets pushed down,
incl. projecting parts and controls

Weight

VPH-1041Q/1041QM: Approx. 30 kg (66 lb 2 oz)
VPH-1042Q/1042QM: Approx. 38 kg (83 lb 12 oz)

Accessories supplied

AC power cord (1)
Spacer for 200" projection (4)

Design and specifications subject to change without notice.

Optional Accessories

Remote controller VPR-722S

Projector pedestal SU-722

Projector suspension support PSS-722, PSS-10

Screen VPS-100F1 (100" flat)

VPS-72HG1 (72" curved)

VPS-100HG1 (100" curved)

VPS-700R (70", rear projection)

Carrying case VLC-1040

CCQ BRS cables

Shielded cable SMF-506 (D-sub 25-pin ↔ 4 BNC)