

VPH-1292Q/QM/QMG

RM-PJ1292

SERVICE MANUAL

REVISED-1

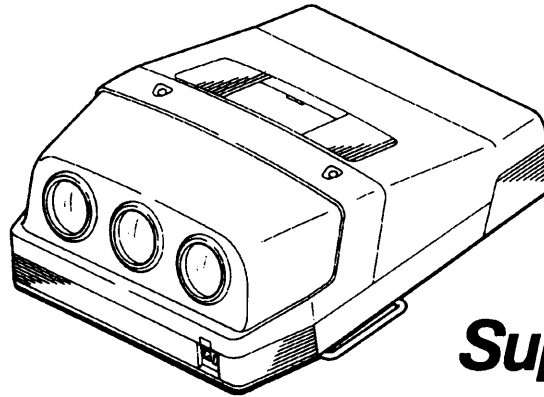

US Model
Canadian Model

VPH-1292Q
Chassis No. SCC-D83J-A

AEP Model

VPH-1292QM
Chassis No. SCC-D82H-A
VPH-1292QMG
Chassis No. SCC-D82J-A

SuperGraphics

MODELS OF THE SAME SERIES

VPH-1292Q/QM/QMG	

SPECIFICATIONS

VPH-1292Q/QM MODEL

General

Dimensions 746 × 386 × 1000 mm (w/h/d)
(29 ³/₈ × 15 ¹/₄ × 39 ³/₈ inches)

Mass 92 kg (202 lb 13 oz)

Power requirements
120 V AC¹⁾, 50/60 Hz
(for the VPH-1292Q)
220 to 240 V AC, 50/60 Hz
(for the VPH-1292QM)

Power consumption
850 W

Operating temperature
0 C° to +40 C° (32 F to 104 F)

Operating humidity
35% to 85%

Storage temperature
- 20 C° to +60 C° (- 4 F to 140 F)

Storage humidity 0% to 90%

— continued on next page —

MULTISCAN PROJECTOR
SONY®

VPH-1292Q/QM MODEL

Optical characteristics

Projection system	3 picture tubes, 3 lenses, horizontal inline system
Picture tube	9-inch (7.7 inches phosphor size) high luminance, optical coupled, electromagnetic focus tubes
Projection lens	HACC (High-resolution Aspherical and Color Corrected) multicoating lenses F 1.15/167 mm
Projected picture size	Factory-adjusted to 120 inches (diagonal measure) Range: 90 to 300 inches (diagonal measure) adjustable
Light output	ANSI lumen ²⁾ (color temperature: 6500° K) 225 ln (fH: 135 kHz, fV: 50 Hz) 190 ln (fH: 15 kHz, fV: 60 Hz) Peak white: 700 ln All white: 300 ln

Electrical characteristics

Color system	NTSC, PAL, SECAM and NTSC ^{4, 43} systems, switched automatically
Resolution	700 TV lines (VIDEO input) 2000 × 1600 pixels (RGB input at fH:94 kHz, fV:60 Hz)
RGB inputs	Horizontal frequency: 15 kHz to 135 kHz Vertical frequency: 38 Hz to 150 Hz
Test signal	Cross-hair test pattern generator is incorporated.
VIDEO INPUT connectors	Y/C: 4-pin mini-DIN type (1) Y (luminance) signal: 1 Vp-p ±2dB, sync negative, 75 ohms terminated C (chrominance) signal: burst 0.286 Vp-p ±2dB, 75 ohms terminated (NTSC) 0.3 Vp-p ±2dB, 75 ohms terminated (PAL) VIDEO: BNC type (1) Composite video input, 1 Vp-p ±2 dB, sync negative 75 ohms terminated

RGB IN R connector: BNC type (1) Red input, 0.7 Vp-p ±2 dB, 75 ohms terminated, positive
RGB IN G/G SYNC connector: BNC type (1) Green input, 0.7 Vp-p ±2dB, 75 ohms terminated, positive Green with sync input, 1 Vp-p ±2dB, 75 ohms terminated, positive
RGB IN B connector: BNC type (1) Blue input, 0.7 Vp-p ±2 dB, 75 ohms terminated, positive
RGB IN SYNC/HD connector: BNC type (1) Composite sync input, 0.6 to 8 Vp-p, high impedance, sync positive/negative Horizontal sync input, 0.6 to 8 Vp-p, high-impedance, sync positive/negative Width: wider than horizontal period(1H)
RGB IN VD connector: BNC type (1) Vertical sync input, 0.6 to 8 Vp-p, high impedance, sync positive/negative Width: wider than horizontal period(1H)
REMOTE 1 connector: 14-pin DIN type (1) <i>(For details, see "Signal assignment" on next page.)</i>
REMOTE 2 connector: D-sub 9-pin DIN type (1) <i>(For details, see "Signal assignment" on next page.)</i>
CONTROL S IN connector: Minijack type (1) 5 Vp-p
VIDEO OUT connector: BNC type (1) Composite video output, 1 Vp-p ±2 dB, impedance 75 ohms loop-through output of the VIDEO IN connector
CONTROL S OUT connector: Minijack type (1) 5 Vp-p

1) 120V operation when using the projector in the North American region
2) ANSI lumen is a measuring method of American National Standard IT 7.215.

Supplied accessories

AA (R6) batteries (3)
AC power cord (1)
Remote control cable (15m (49.5 feet)) (1)
Remote control unit RM-PJ1292 (1)
Grip (4)
Hexagonal wrench (1)
Operating Instructions (1)

Optional accessories

Signal Interface Switcher
PC-1271/1271M

Projector Suspension Support
PSS-1270

Screens
VPS-100FH (100" flat)
VPS-120FH (120" flat)

Interface boards
IFB-11: Analog RGB inputs with five BNC type connectors
IFB-20: Analog RGB input with D-sub 9-pin type connector
IFB-30: Digital RGB input with D-sub 9-pin type connector
IFB-1000: Composite video input with BNC type connector
S-Video input with mini DIN 4-pin type connector
IFB-1200: Component video input with three BNC type connectors
IFB-1300: Y/PB/PR input three BNC type connectors
IFB-3000: Video three input, Y/C video input or Component video input with three BNC type connectors
IFB-101: Index board

Signal Interface Unit
IFU-1271/1271M

Signal assignment

Y/C connector (4-pin mini-DIN type)

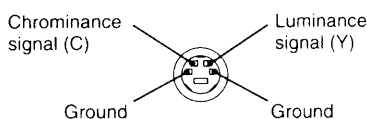

REMOTE 1 connector (14-pin DIN type)

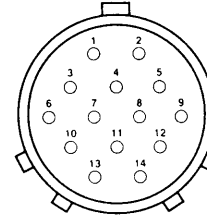

Pin No.	Signal
1	GND
2	HD/Composite Sync
3	SIRCS
4	NC (No Connection)
5	GND (SIRCS)
6	B/C
7	GND (B/C)
8	GND (B/Y)
9	G/Y
10	RGB/Video
11	R/Composite video
12	Composite video/YC
13	NC (No Connection)
14	VD

REMOTE 2 connector (D-sub 9-pin type, RS-422 type format)

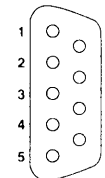

Pin No	Signal
1	Frame Ground
2	Transit A
3	Receive B
4	Receive common
5	Spare
6	Transmit common
7	Transmit B
8	Receive A
9	Frame ground

Design and specifications are subject to change without notice.

VPH-1292QMG MODEL

General

Dimensions	746 × 386 × 1000 mm (w/h/d) (29 3/8 × 15 1/4 × 39 3/8 inches)
Mass	92 kg (202 lb 13 oz)
Power requirements	220 to 240V AC, 50/60 Hz
Power consumption	850 W
Operating temperature	0 C° to +40 C° (32 F to 104 F)
Operating humidity	35% to 85%
Storage temperature	- 20 C° to +60 C° (- 4 F to 140 F)
Storage humidity	0% to 90%

Optical characteristics

Projection system	3 picture tubes, 3 lenses, horizontal inline system
Picture tube	9-inch (7.7 inches phosphor size) high luminance, optical coupled, electromagnetic focus tubes
Projection lens	HACC (High-resolution Aspherical and Color Corrected) multicoating lenses F 1.15/167 mm
Projected picture size	Factory-adjusted to 120 inches (diagonal measure) Range: 90 to 300 inches (diagonal measure) adjustable
Light output	ANSI lumen ¹⁾ (color temperature: 6500° K) 225 ln (fH: 135 kHz, fV: 50 Hz) 190 ln (fH: 15 kHz, fV: 60 Hz) Peak white: 700 ln All white: 300 ln

Electrical characteristics

Color system	NTSC, PAL, SECAM and NTSC 4.43 systems, switched automatically (input from the IFB-1000)
Resolution	700 TV lines (input from the IFB-1000) 2000 × 1600 pixels (RGB input at fH:94 kHz, fV:60 Hz)
RGB inputs	Horizontal frequency: 15 kHz to 135 kHz Vertical frequency: 38 Hz to 150 Hz
Test signal	Cross-hair test pattern generator is incorporated.
RGB IN R connector: BNC type (1)	Red input, 0.7 Vp-p ±2 dB, 75 ohms terminated, positive
RGB IN G/G SYNC connector: BNC type (1)	Green input, 0.7 Vp-p ±2dB, 75 ohms terminated, positive Green with sync input, 1 Vp-p ±2dB, 75 ohms terminated, positive
RGB IN B connector: BNC type (1)	Blue input, 0.7 Vp-p ±2 dB, 75 ohms terminated, positive
RGB IN SYNC/HD connector: BNC type (1)	Composite sync input, 0.6 to 8 Vp-p, high impedance, sync positive/negative Horizontal sync input, 0.6 to 8 Vp-p, high-impedance, sync positive/negative Width: wider than horizontal period(1H)
RGB IN VD connector: BNC type (1)	Vertical sync input, 0.6 to 8 Vp-p, high impedance, sync positive/negative

1) ANSI lumen is a measuring method of American National Standard IT 7.215.

Width: wider than horizontal
 period(1H)
 REMOTE 1 connector: 14-pin DIN type (1)
*(For details, see "Signal assignment"
 on next page.)*
 REMOTE 2 connector: D-sub 9-pin DIN type (1)
*(For details, see "Signal assignment"
 on next page.)*
 CONTROL S IN connector: Minijack type (1)
 5 Vp-p
 CONTROL S OUT connector: Minijack type (1)
 5 Vp-p

with three BNC type connectors
 IFB-1300:Y/PB/PR input three
 BNC type connectors
 IFB-3000:Video three input, Y/C
 video input or Component video
 input with three BNC type
 connectors
 IFB-101:Index board
 Signal Interface Unit
 IFU-1271M

Supplied accessories

AA (R6) batteries (3)
 AC power cord (1)
 Remote control cable (15m (49.5 feet)) (1)
 Remote control unit RM-PJ1292 (1)
 Grip (4)
 Hexagonal wrench (1)
 Operating Instructions (1)

Optional accessories

Signal Interface Switcher
 PC-1271M
 Projector Suspension Support
 PSS-1270
 Screens
 VPS-100FH (100" flat)
 VPS-120FH (120" flat)
 Interface boards
 IFB-11: Analog RGB inputs with
 five BNC type connectors
 IFB-20:Analog RGB input with D-
 sub 9-pin type connector
 IFB-30:Digital RGB input with D-
 sub 9-pin type connector
 IFB-1000:Composite video input
 with BNC type connector
 S-Video input with mini DIN 4-
 pin type connector
 IFB-1200:Component video input

Signal assignment

REMOTE 1 connector (14-pin DIN type)

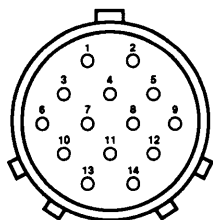

Pin No.	Signal
1	GND
2	HD/Composite Sync
3	SIRCS
4	NC (No Connection)
5	GND (SIRCS)
6	B/C
7	GND (B/C)
8	GND (B/Y)
9	G/Y
10	RGB/Video
11	R/Composite video
12	Composite video/YC
13	NC (No Connection)
14	VD

REMOTE 2 connector (D-sub 9-pin type, RS-422 type format)



Pin No	Signal
1	Frame Ground
2	Transit A
3	Receive B
4	Receive common
5	Spare
6	Transmit common
7	Transmit B
8	Receive A
9	Frame ground

Design and specifications are subject to change without notice.

WARNING!!

AN ISOLATION TRANSFORMER SHOULD BE USED DURING ANY SERVICE TO AVOID POSSIBLE SHOCK HAZARD, BECAUSE OF LIVE CHASSIS. THE CHASSIS OF THIS RECEIVER IS DIRECTLY CONNECTED TO THE AC POWER LINE.

SAFETY-RELATED COMPONENT WARNING!!

COMPONENTS IDENTIFIED BY SHADING AND MARK \triangle ON THE SCHEMATIC DIAGRAMS, EXPLODED VIEWS AND IN THE PARTS LIST ARE CRITICAL TO SAFE OPERATION. REPLACE THESE COMPONENTS WITH SONY PARTS WHOSE PART NUMBERS APPEAR AS SHOWN IN THIS MANUAL OR IN SUPPLEMENTS PUBLISHED BY SONY. CIRCUIT ADJUSTMENTS THAT ARE CRITICAL TO SAFE OPERATION ARE IDENTIFIED IN THIS MANUAL. FOLLOW THESE PROCEDURES WHENEVER CRITICAL COMPONENTS ARE REPLACED OR IMPROPER OPERATION IS SUSPECTED.

ATTENTION!!

AFIN D'EVITER TOUT RISQUE D'ELECTROCUTION PROVENANT D'UN CHÂSSIS SOUS TENSION, UN TRANSFORMATEUR D'ISOLEMENT DOIT ETRE UTILISÉ LORS DE TOUT DÉPANNAGE. LE CHÂSSIS DE CE RÉCEPTEUR EST DIRECTEMENT RACCORDÉ À L'ALIMENTATION SECTEUR.

ATTENTION AUX COMPOSANTS RELATIFS À LA SÉCURITÉ!!

LES COMPOSANTS IDENTIFIÉS PAR UNE TRAME ET PAR UNE MARQUE \triangle SUR LES SCHÉMAS DE PRINCIPE, LES VUES EXPLOSÉES ET LES LISTES DE PIÈCES SONT D'UNE IMPORTANCE CRITIQUE POUR LA SÉCURITÉ DU FONCTIONNEMENT. NE LES REMPLACER QUE PAR DES COMPOSANTS SONY DONT LE NUMÉRO DE PIÈCE EST INDIQUÉ DANS LE PRÉSENT MANUEL OU DANS DES SUPPLÉMENTS PUBLIÉS PAR SONY. LES RÉGLAGES DE CIRCUIT DONT L'IMPORTANCE EST CRITIQUE POUR LA SÉCURITÉ DU FONCTIONNEMENT SONT IDENTIFIÉS DANS LE PRÉSENT MANUEL. SUIVRE CES PROCÉDURES LORS DE CHAQUE REMPLACEMENT DE COMPOSANTS CRITIQUES, OU LORSQU'UN MAUVAIS FONCTIONNEMENT EST SUSPECTÉ.

SAFETY CHECK-OUT (US Model only)

After correcting the original service problem, perform the following safety checks before releasing the set to the customer:

1. Check the area of your repair for unsoldered or poorly-soldered connections. Check the entire board surface for solder splashes and bridges.
2. Check the interboard wiring to ensure that no wires are "pinched" or contact high-wattage resistors.
3. Check that all control knobs, shields, covers, ground straps, and mounting hardware have been replaced. Be absolutely certain that you have replaced all the insulators.
4. Look for unauthorized replacement parts, particularly transistors, that were installed during a previous repair. Point them out to the customer and recommend their replacement.
5. Look for parts which, though functioning, show obvious signs of deterioration. Point them out to the customer and recommend their replacement.
6. Check the line cords for cracks and abrasion. Recommend the replacement of any such line cord to the customer.
7. Check the B+ and HV to see if they are at the values specified. Make sure your instruments are accurate; be suspicious of your HV meter if sets always have low HV.
8. Check the metal trim, metallized knobs, screws, and all other exposed metal parts for AC leakage.
Check leakage as described below.

LEAKAGE TEST

The AC leakage from any exposed metal part to earth ground and from all exposed metal parts to any exposed metal part having a return to chassis, must not exceed 0.5mA (500 microampers). Leakage current can be measured by any one of three methods.

1. A commercial leakage tester, such as the Simpson 229 or RCA WT-540A. Follow the manufactures' instructions to use these instruments.
2. A battery-operated AC milliammeter. The Data Precision 245 digital multimeter is suitable for this job.
3. Measuring the voltage drop across a resistor by means of a VOM or battery-operated AC voltmeter. The "limit" indication is 0.75V, so analog meters must have an accurate low-voltage scale. The Simpson 250 and Sanwa SH-63Trd are examples of a passive VOM that is suitable. Nearly all battery operated digital multimeters that have a 2V AC range are suitable. (See Fig. A)

HOW TO FIND A GOOD EARTH GROUND

A cold-water pipe is guaranteed earth ground; the cover-plate retaining screw on most AC outlet boxes is also at earth ground. If the retaining screw is to be used as your earth-ground, verify that it is at ground by measuring the resistance between it and a cold-water pipe with an ohmmeter. The reading should be zero ohms. If a cold-water pipe is not accessible, connect a 60-100 watts trouble light (not a neon lamp) between the hot side of the receptacle and the retaining screw. Try both slots, if necessary, to locate the hot side of the line, the lamp should light at normal brilliance if the screw is at ground potential. (See Fig. B)

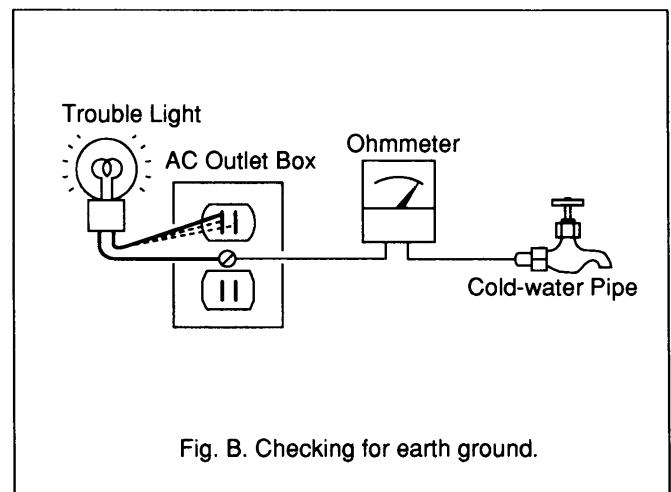
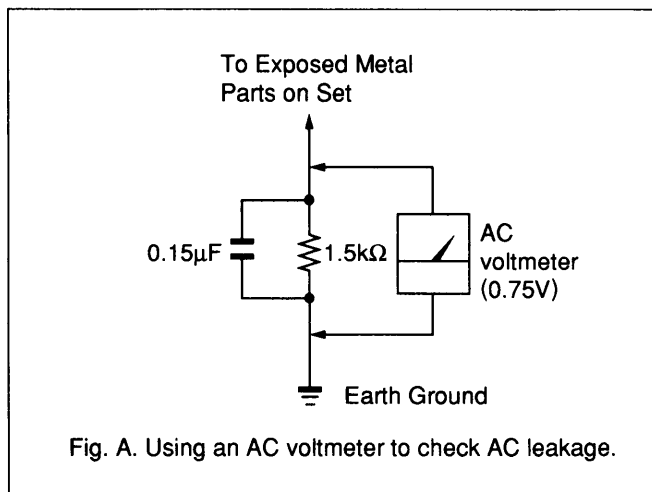

TABLE OF CONTENTS

<u>Section</u>	<u>Title</u>	<u>Page</u>	<u>Section</u>	<u>Title</u>	<u>Page</u>
1. GENERAL			4. SAFETY RELATED ADJUSTMENT		109
1-1. OPERATING INSTRUCTION			5. ELECTRICAL ADJUSTMENT		
Features		9	5-1. CAR, CAG, CAB, CBR, CBG and CBB Boards Adjustment		113
Location and Function of Controls		10	5-2. DA Board Adjustment		117
Projecting		13	5-3. DE Board Adjustment		119
Centering Adjustment		20	6. DIAGRAMS		
Installation Diagrams		21	6-1. Circuit Boards Location		122
System Connections		22	6-2. Block Diagrams		123
List of Messages		26	6-3. Frame Schematic Diagram		145
Index		29	6-4. Schematic Diagrams and Printed Wiring Boards		148
1-2. INSTALLATION			BA Board		149
Installation Procedures		30	BB and BD Boards		158
Installation Diagrams		30	BM Board		166
Modifying Parts		38	BC, L and QM Boards		171
Location and Function of Connectors		42	DA Board		177
Connecting Directly to the Projector		43	DB Board		185
Connecting When the Projector Is Away From Other Equipment		46	DE Board		193
Connecting More Than Four Input Sources		48	DCA and DCC Boards		205
Adjustment Procedures		50	DC Board		207
For Remote Control		50	DD Board		213
PAGE Displays and Test Patterns		53	DM Board		219
Adjusting the Focus		56	Y Board		224
Adjusting the Registration		60	DG, NA and NB Boards		231
Fine Adjustment for Each Input Signal		72	EA Board		235
Resetting the Data		76	EEA and EEB Boards		238
Projecting the Setting		78	E Board		244
Adjusting the Picture Quality		78	EBB Board		250
Changing the Initialization Period		79	CFB Board		255
Turning off the "OFF" indication on the Screen		79	EBA, EBC and EBD Boards		257
List of Messages		80	EBRG Board		260
List of the Projection Distance by Angle of Optical Axis		84	EC and ED Boards		267
Index		90	CAR Board		274
2. DISASSEMBLY			CAG Board		281
2-1. Cover Removal		91	CAB Board		288
2-2. Lens Removal		91	PA, PB and PC Boards		295
2-3. Power Block Removal		92	CBR Board		302
2-4. ED Block Removal		92	CBG Board		308
2-5. High-Voltage Block Removal		93	CBB Board		314
2-6. Interface Unit, BA, BB and BC Boards Removal		93	U1 and U2 Boards		320
2-7. Y, DA, DB, DD and DE Boards Removal		94	U3 Board		325
2-8. EBRG and EBB Boards Removal		94	U4 Board		330
2-9. DM Board Removal		95	6-5. Semiconductors		333
2-10. Attachment Direction of the DC Fan		95	7. EXPLODED VIEWS		
2-11. Picture Tube Removal		96	7-1. Cover		336
2-12. CAB and CBB Boards Removal		96	7-2. ED Block		337
3. SET-UP ADJUSTMENT			7-3. Power Block		338
3-1. Neck Assembly Installation		97	7-4. C Shield Block		339
3-2. Work Condition for Adjustment		97	7-5. Picture Tube		340
3-3. Focus Adjustment		98	7-6. Chassis		341
3-4. Registration Adjustment		104	8. ELECTRICAL PARTS LIST		342
3-5. White Balance Adjustment		105			
3-6. Blanking Adjustment		107			
3-7. High-Voltage Picture Bending Adjustment		108			

SECTION 1 GENERAL

The operating instructions mentioned here are partial abstracts from the Operating Instruction Manual and Installation Manual. The page numbers of the Operating Instruction Manual and Installation Manual remain as in the manual.

1-1. OPERATING INSTRUCTION

VPH-1292Q/QM MODEL ONLY

Features

Multiscan projector

This projector accepts and automatically detects horizontal scanning frequencies between 15 kHz and 135 kHz and vertical scanning frequencies between 38 Hz and 150 Hz. In addition to high-resolution pictures from computers, you can also project pictures from teletext decoders, VCRs, and video cameras.

Bright image – light output 700 lumen¹⁾

A newly developed phosphor, large CRT, and improved high voltage circuitry provides super brightness.

High resolution – 2000 × 1600 pixels

High-quality picture with a resolution of 2000 × 1600 pixels is obtained through the combination of a newly developed 9" electromagnetic focus CRT with the electron gun to improve the beam spot and a hybrid Sony HACC (High-resolution Aspherical and Color Corrected) lens. In addition, since the projector adopts the optical coupling technologies, double-focus lens system and an anti-reflection coating, you can obtain fine-detail, sharp pictures with improved contrast in the corners and screen center.

Wireless and wired remote control

You can control all adjustments remotely from both the front and rear of the projector with the supplied remote control. You can also use the control as a wired remote control by connecting to the projector with the supplied cable.

On-screen display

Adjustment instructions and indicators such as picture controls, guide and error messages, can be displayed on the screen. The current setting of each control and input condition can also be displayed.

Other features

Four color systems available

NTSC, PAL, SECAM, or NTSC_{4:4:4} color system is selected automatically.

Various installation possibilities

The projector is designed to be installed on a desk, floor, or ceiling and can be used with a flat screen or rear projection screen.

Illuminated remote control and control panel

When you press the LIGHT button on the remote control or projector control panel, the indications light for easy operation in dim conditions.

Internal test signal

You can easily adjust the centering with the built-in cross-hair test signal. No external test signal is needed.

VPH-1292QMG MODEL ONLY

Features

Multiscan projector

This projector accepts and automatically detects horizontal scanning frequencies between 15 kHz and 135 kHz and vertical scanning frequencies between 38 Hz and 150 Hz. In addition to high-resolution pictures from computers, you can also project pictures from teletext decoders, VCRs, and video cameras.

Bright image – light output 700 lumen¹⁾

A newly developed phosphor, large CRT, and improved high voltage circuitry provides super brightness.

High resolution – 2000 × 1600 pixels

High-quality picture with a resolution of 2000 × 1600 pixels is obtained through the combination of a newly developed 9" electromagnetic focus CRT with the electron gun to improve the beam spot and a hybrid Sony HACC (High-resolution Aspherical and Color Corrected) lens. In addition, since the projector adopts the optical coupling technologies, double-focus lens system and an anti-reflection coating, you can obtain fine-detail, sharp pictures with improved contrast in the corners and screen center.

Wireless and wired remote control

You can control all adjustments remotely from both the front and rear of the projector with the supplied remote control. You can also use the control as a wired remote control by connecting to the projector with the supplied cable.

On-screen display

Adjustment instructions and indicators such as picture controls, guide and error messages, can be displayed on the screen. The current setting of each control and input condition can also be displayed.

Other features

Four color systems available

NTSC, PAL, SECAM, or NTSC_{4:4:4} color system is selected automatically (when installing the optional IFB-1000 to the projector).

Various installation possibilities

The projector is designed to be installed on a desk, floor, or ceiling and can be used with a flat screen or rear projection screen.

Illuminated remote control and control panel

When you press the LIGHT button on the remote control or projector control panel, the indications light for easy operation in dim conditions.

Internal test signal

You can easily adjust the centering with the built-in cross-hair test signal. No external test signal is needed.

1) 225 ANSI lumen (FH: 135 kHz, FV: 50 Hz, 6500°K)
190 ANSI lumen (FH: 15 kHz, FV: 60 Hz, 6500°K)

1) 225 ANSI lumen (FH: 135 kHz, FV: 50 Hz, 6500°K)
190 ANSI lumen (FH: 15 kHz, FV: 60 Hz, 6500°K)

Location and Function of Controls

Front

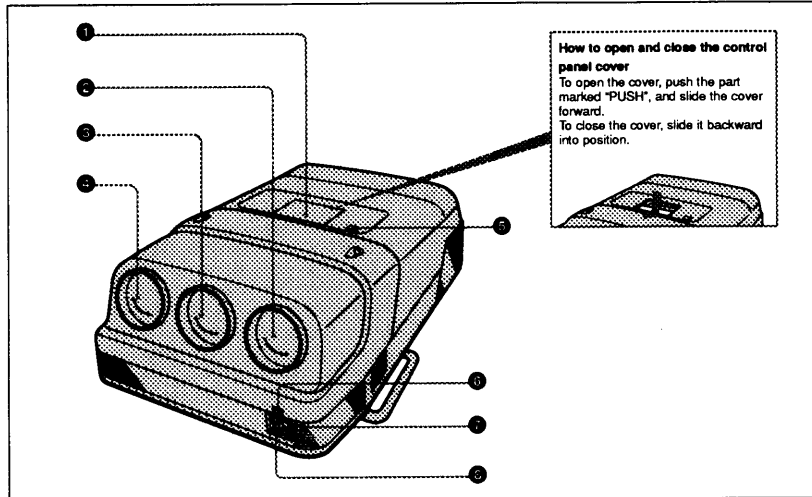

How to open and close the control panel cover
 To open the cover, push the part marked "PUSH", and slide the cover forward.
 To close the cover, slide it backward into position.

1 Control panel

The control keys are inside the panel.

2 Red lens

3 Green lens

4 Blue lens

5 Error code window (inside the cover)

6 Front remote control detector

7 MAIN POWER switch

8 AC IN socket

Connect the supplied AC power cord here. This socket accepts 220 to 240 V AC.

Location and Function of Controls

Bottom

Carrying the projector

You can carry the projector by using the handle.

Using the side handles

Pull out to use. To put away the side handle, slide it backward.

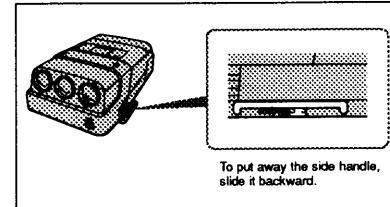

To put away the side handle, slide it backward.

Inserting the front or rear grips

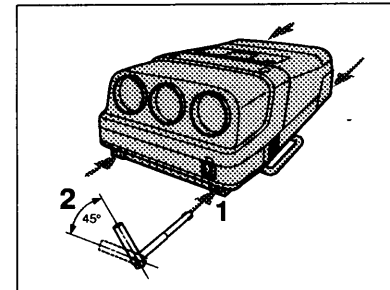

1 Insert the grip as illustrated above.

2 Turn the grip until it is fixed.

Removing the front or rear grips

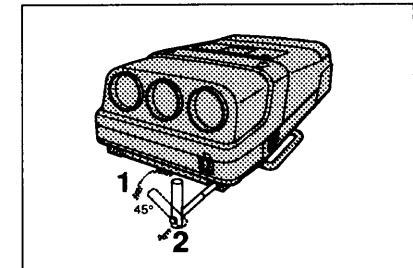

1 While pressing the grip release button, turn the grip until it is unfixed.

2 Pull out the handle.

Rear

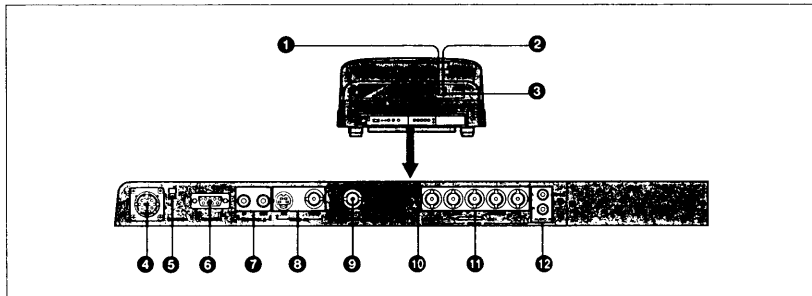

1 Rear remote control detector

2 POWER indicator
Lights in green when the power is on.

3 STANDBY indicator
Lights in red when the MAIN POWER switch is turned on. This means that you can control the projector with the remote control.

Note
When the MAIN POWER switch is turned off, there will be a slight delay before the indicator goes off.

4 REMOTE 1 connector (14-pin, male)
Connects to the REMOTE 1 connector of the optional PC-1271/1271M Signal Interface Switcher.

5 SBNC switch
Normally, set to the NORMAL.
If you wish to project the high resolution picture using the PC-1271/1271M Signal Interface Switcher, set to the SBNC position.
For details, see "When Projecting the High Resolution Pictures" on page 32 (E).

6 REMOTE 2 connector (9-pin, female)
Connects the RS-422 interface for communication with a computer.

7 CONTROL S IN/OUT jacks (phono type)
Connect to the CONTROL S connectors of other Sony equipment. You can control the whole system with a single remote control.

CONTROL S IN: Connects to the CONTROL S OUT jack of the supplied remote control to be used as a wired remote control.

Note
When using this connector, the remote control detector on the projector does not function.

8 VIDEO IN connectors
Y/C (4-pin, mini-DIN type): Connects to the Y/C video output (S VIDEO OUT) of a VCR.
VIDEO (BNC type): Connects to the composite video output of video equipment.

Note
The VIDEO connector is disconnected automatically when a cable is connected to the Y/C connector.

9 VIDEO OUT connector (BNC type)
Connects to the video input of a color monitor. The output signal is the loop-through output from the input signal to the VIDEO IN connectors.

10 Indicator
Lights when INPUT A mode is selected.

11 RGB IN connectors (BNC type) R, G/G SYNC, B, SYNC/HD, VD connectors:
Connect to the RGB outputs of a computer or a video camera.

12 AUDIO IN L/R jacks (phono type)
Not used.

Rear

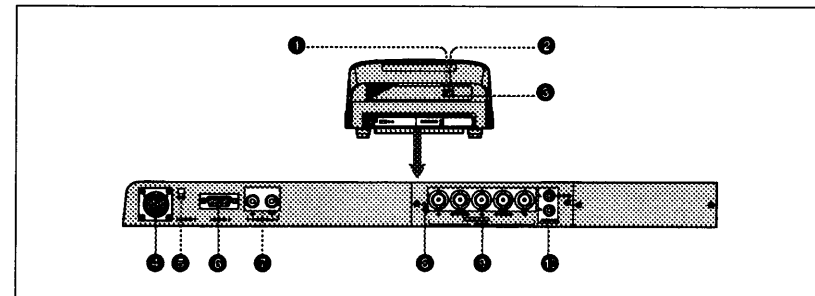

1 Rear remote control detector

2 POWER indicator
Lights in green when the power is on.

3 STANDBY indicator
Lights in red when the MAIN POWER switch is turned on. This means that you can control the projector with the remote control.

Note
When the MAIN POWER switch is turned off, there will be a slight delay before the indicator goes off.

4 REMOTE 1 connector (14-pin, male)
Connects to the REMOTE 1 connector of the optional PC-1271M Signal Interface Switcher.

5 SBNC switch
Normally, set to the NORMAL.
If you wish to project the high resolution picture using the PC-1271M Signal Interface Switcher, set to the SBNC position.
For details, see "When Projecting the High Resolution Pictures" on page 32 (E).

6 REMOTE 2 connector (9-pin, female)
Connects the RS-422 interface for communication with a computer.

7 CONTROL S IN/OUT jacks (phono type)
Connect to the CONTROL S connectors of other Sony equipment. You can control the whole system with a single remote control.

CONTROL S IN: Connects to the CONTROL S OUT jack of the supplied remote control to be used as a wired remote control.

Note
When using this connector, the remote control detector on the projector does not function.

8 Indicator
Lights when INPUT A mode is selected.

9 RGB IN connectors (BNC type) R, G/G SYNC, B, SYNC/HD, VD connectors:
Connect to the RGB outputs of a computer or a video camera.

10 AUDIO IN L/R jacks (phono type)
Not used.

Location and Function of Controls

Remote Control

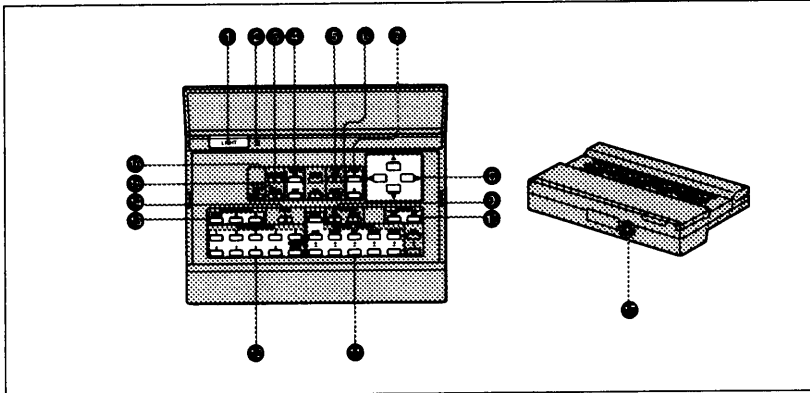

1 LIGHT button

Illuminates key indicators on the remote control. If you do not use the keys for approximately 30 seconds, the light automatically goes out.

2 Transmission indicator

Lights each time you press a key. Replace the batteries when this indicator does not light.

3 MEMORY key

Stores various adjustment data into memory.

4 STATUS ON/OFF key

ON: Restores the on-screen display.
OFF: Removes the on-screen display.

Note

The PAGE display appears even when you press the OFF key.

5 RGB SIZE key

Adjusts the size of the picture for the video and RGB signal inputs.

To adjust the size, press this key. You can adjust the picture size with the four arrow keys. After adjustment, save the data by pressing the MEMORY key.

◀: Reduces the horizontal size.

▶: Expands the horizontal size.

▲: Expands the vertical size.

▼: Reduces the vertical size.

6 RGB SHIFT key

Adjusts the shift of the picture for shift of the picture the RGB signal input.

To adjust the shift, press this key. You can adjust the picture shift with four arrow keys. The picture shifts according to the direction of the arrow. After adjustment, save the data by pressing the MEMORY key.

Note

This key does not function with the composite or Y/C video signal input.

7 CENT R/B keys

Adjust the centering of the red and blue.

You can adjust the centering with the four arrow keys.

CENT R: Enters the red centering adjustment mode.

CENT B: Enters the blue centering adjustment mode.

8 Arrow keys

Used for various adjustment functions.

9 PJ MUTING PIC key

Cuts off the picture. To restore the picture, press the key again or the CONTR + key.

10 POWER ON/OFF keys

Turn the projector on and off.

11 PICTURE CONTROL keys

Adjust picture condition: hue, sharpness, brightness, color, and contrast. To restore the default levels, press the RESET key.

12 SWITCHER/INDEX keys¹⁾

When the SWITCHER/INDEX select switch is set to SWITCHER

Designate the input from the switcher when the PC 1271M Signal Interface Switcher is connected. The SECOND key is used when two switchers are connected.

To select the input from the second switcher (when the SINGLE/SECOND/OTHER switch on the switcher is set to SECOND), press a number key between 1 and 8 after pressing the SECOND key.

When the SWITCHER/INDEX select switch is set to INDEX

These keys function when the optional IFB-101 Interface Board is installed and multiple projectors are connected.

For details, refer to the Operating Instructions of the IFB-101.

13 INPUT SELECT keys

Select the input signal.

A: The signal input from the RGB IN connectors

B: The signal input from the connectors of B section (when the optional interface unit is installed)

14 PAGE key

Displays and switches between the following four on-screen displays. (You can adjust parameters on PAGE 1, 2 or 3.)

PAGE 1: Displays the status of STATUS ON/OFF, PIC MUTING ON/OFF.

PAGE 2: Displays the picture conditions parameters; contrast, color, brightness, sharpness and hue.

PAGE 3: Displays the color temperature, clamp setting and vertical shift range.

PAGE 4: Displays the input signal conditions; fH, fV, H/C-sync, V-sync, Sync on Green, input signal, and registration memory block assignment.

15 SWITCHER/INDEX select switch¹⁾

Selects the SWITCHER/INDEX key function.

When using the switcher as the input selector, set to SWITCHER. When using the IFB-101 Interface Board and multiple projectors, set to INDEX.

16 ENTER key¹⁾

Functions when the optional IFB-101 Interface Board is attached and multiple projectors are connected.

For details, refer to the Operating Instructions of the IFB-101.

17 CONTROL S OUT connector

Connect the supplied remote control cable to this connector and to the CONTROL S IN connector on the projector for wired remote control application.

Notes for wireless remote control operation

- Be sure that there are no obstructions between the remote control and the projector.
- Operation range is limited. The shorter the distance between the remote control and the projector, the wider the angle within which the remote control can operate the projector.

1) These keys are not supplied on the control panel of the projector.

Location and Function of Controls

Battery Installation

- 1 Push to open the lid.

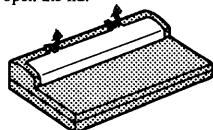

- 2 Install three AA (R6) batteries (supplied) with the correct polarity.

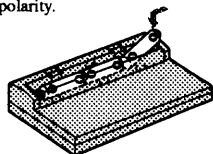

- 3 Replace the lid.

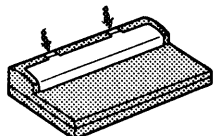

Notes on batteries

- If the projector does not operate properly, the batteries might be worn out. Replace all three of them with new ones.
- The life of the batteries depends on the frequency of usage and how often you use the LIGHT button. If they are worn out quickly, replace them with new alkaline batteries.
- To avoid damage from possible battery leakage, remove the batteries when the remote control will not be used for a long time.

Connecting the remote control to the projector

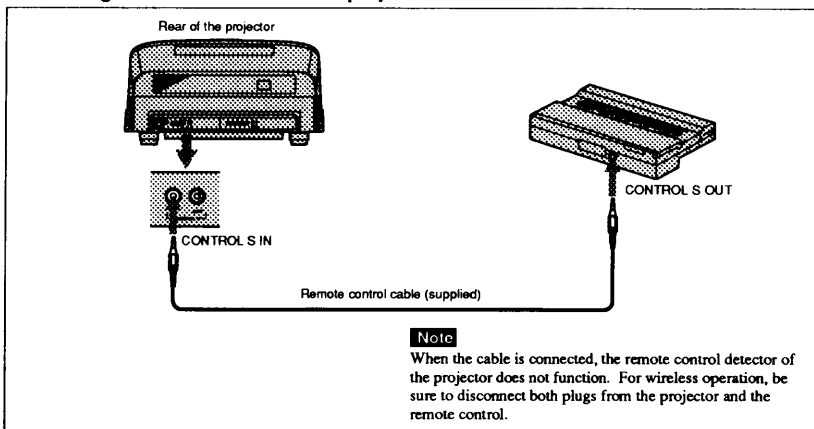

12 (E)

Projecting

About the Initialization Screen

Before you project the picture, make sure to turn on the projector and allow it to warm up for 20 minutes.

The projector is designed with a warm-up period of about 20 minutes after turning on the power. During this period, it displays a white screen with the message shown below. 35 seconds after the warming up starts, the message will disappear temporarily and will appear subsequently for 5 seconds every 30 seconds.

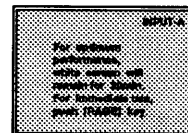

Press the PAGE key to cancel the warming up, if you wish to see the picture immediately.

13 (E)

Projecting

Projection Procedure

You can also use the keys on the control panel to operate the projector. The keys have the same names as on the remote control.

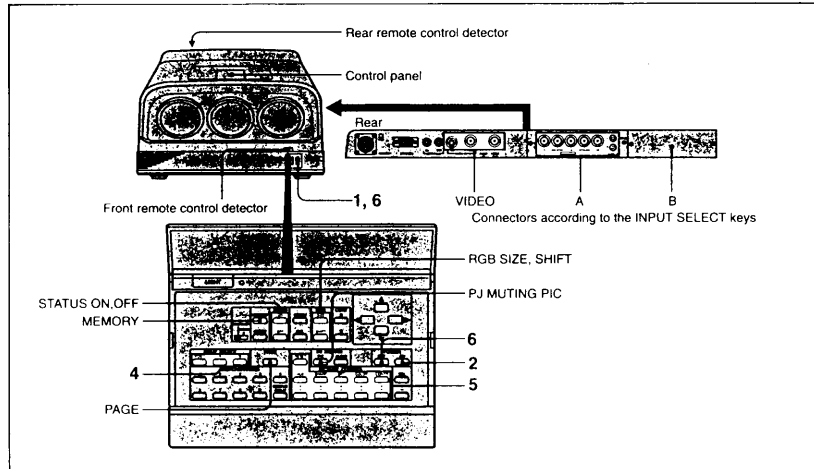

- 1 Turn on the MAIN POWER switch on the projector.
- 2 Turn on the projector by pressing the POWER ON key on the remote control or on the control panel of the projector.

The initialization screen appears on the screen.
If you want to see the picture immediately, press the PAGE key to cancel the warming up.

- 3 Turn on the connected equipment.
- 4 Select the input signal type by pressing the INPUT SELECT key.
VIDEO: The signal input from the VIDEO IN (Y/C or VIDEO) controls is projected.
A: The signal input from the RGB IN connectors is projected.
B: The signal input from the connectors of B section is projected. (when the optional interface board is installed)
 When the PC-1271/1271M Signal Interface Switcher is connected, set the SWITCHER/INDEX select switch to SWITCHER and then select the input with the number keys between 1 and 8. If two switchers are connected, press the SECOND key and then the number key.

Projecting

Projection Procedure

You can also use the keys on the control panel to operate the projector. The keys have the same names as on the remote control.

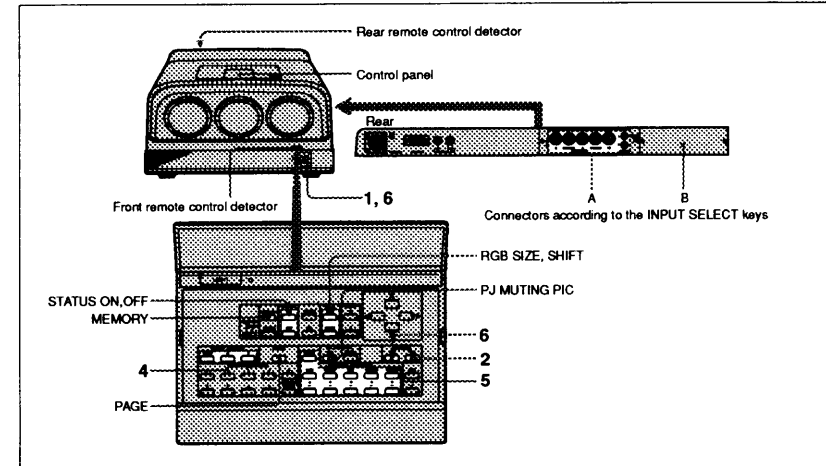

- 1 Turn on the MAIN POWER switch on the projector.
- 2 Turn on the projector by pressing the POWER ON key on the remote control or on the control panel of the projector.

The initialization screen appears on the screen.
If you want to see the picture immediately, press the PAGE key to cancel the warming up.

- 3 Turn on the connected equipment.
- 4 Select the input signal type by pressing the INPUT SELECT key.
A: The signal input from the RGB IN connectors is projected.
B: The signal input from the connectors of B section is projected. (when the optional interface board is installed)
 When the PC-1271M Signal Interface Switcher is connected, set the SWITCHER/INDEX select switch to SWITCHER and then select the input with the number keys between 1 and 8. If two switchers are connected, press the SECOND key and then the number key.

VPH-1292Q/QM MODEL ONLY

- 5 Adjust the picture.
- 6 To turn the power off, press the POWER OFF key on the remote control or on the control panel of the projector, then turn the MAIN POWER switch on the projector.

To remove the on-screen display

Press the STATUS OFF key.
PAGE display remains even when you press the STATUS OFF key.
To restore the on-screen display, press the STATUS ON key.

To turn off the picture

Press the PJ MUTING PIC key.
To restore the previous brightness level, press the PJ MUTING PIC key again or the CONTR + key.

Notes on projecting a picture input from the VIDEO IN connectors

- You can adjust the picture size with the RGB SIZE and arrow keys.
 - You cannot adjust the picture shift.
- For details, see "Adjusting the Size and Shift of the Picture" on page 20 (E).*

Notes on projecting a picture input from the RGB IN connectors

Adjust the size and shift of the picture using the RGB SIZE/SHIFT key, RGB SIZE/SHIFT key and arrow keys, if necessary.
For details, see "Adjusting the Size and Shift of the Picture" on page 20 (E).

VPH-1292QMG MODEL ONLY

- 5 Adjust the picture.
- 6 To turn the power off, press the POWER OFF key on the remote control or on the control panel of the projector, then turn the MAIN POWER switch on the projector.

To remove the on-screen display

Press the STATUS OFF key.
PAGE display remains even when you press the STATUS OFF key.
To restore the on-screen display, press the STATUS ON key.

To turn off the picture

Press the PJ MUTING PIC key.
To restore the previous brightness level, press the PJ MUTING PIC key again or the CONTR + key.

Notes on projecting a picture input from the RGB IN connectors

Adjust the size and shift of the picture using the RGB SIZE/SHIFT key, RGB SIZE/SHIFT key and arrow keys, if necessary.
For details, see "Adjusting the Size and Shift of the Picture" on page 20 (E).

Projecting

Adjusting the Picture

Use the PICTURE CONTROL keys on the remote control. The adjustment levels are displayed on the screen having a range of MIN, 1, 2, . . . , 98, 99, MAX.



- CONTR +/- keys** +: Increases picture contrast.
 -: Decreases picture contrast.
- COLOR +/- keys** +: Increases color intensity.
 -: Decreases color intensity.
- BRT +/- keys** +: Makes the picture brighter.
 -: Makes the picture darker.
- SHARP +/- keys** +: Makes the picture sharper.
 -: Makes the picture softer.
- HUE +/- keys** +: Makes skin tones greenish.
 -: Makes skin tones purplish.

- The COLOR, SHARP, and HUE controls do not function on pictures input from the RGB IN connectors.
- The HUE control does not function with the PAL or SECAM color source.

To reset the picture settings to the factory preset levels

Press the RESET key.

The factory preset levels will be displayed on the screen.

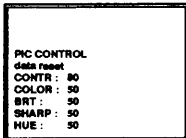

Displaying the Current Control Settings and Conditions

Press the PAGE key to display the following four on-screen displays. You can adjust the parameters on PAGE 1, 2, or 3. The display changes in the following order every time you press the PAGE key:

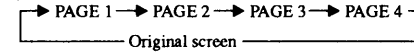

PAGE 1



STATUS: ON/OFF

The setting is stored even when the power is turned off. If the on-screen display does not appear, check that STATUS ON is displayed.

PIC MUTING: ON/OFF

Whenever the power is turned on, PIC MUTING is set to OFF. If the picture does not appear, check that PIC MUTING is set to ON.

PAGE 2

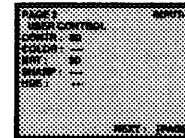

Picture settings; contrast, color, brightness, sharpness, and hue level are displayed.

The levels can be changed independently for the signal input from different input connectors. (You can check from the message displayed in the upper right corner of the screen.)

"—" indicates that the control does not function with the current input signal. (In this case, the input signal is RGB.)

To change the levels, use the PICTURE CONTROL key.

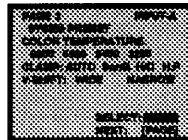

The color temperature, clamp, and V-shift adjustment mode settings are displayed.
 The selected item blinks in green.
 To change the setting, adjust by pressing ◀, ▶, ▲ and ▼ keys.

COLOR TEMPERATURE: 9300/6500/5400/3200

Select the appropriate color temperature according to your application and the picture source.

The color temperature of the projector is preset to 6500 at the factory.

V-SHIFT: WIDE/NARROW

The V-shift of the projector is preset to WIDE at the factory. When some particular RGB signals are input to the projector, the picture may be distorted vertically. In this case, set to NARROW. Adjustable range in the lower direction will become narrow.

If the horizontal frequency of the input signal is above 100 kHz, the V-SHIFT is automatically set to NARROW.

For details of the clamp setting, see "Correcting the Luminance of the Picture – Clamp Setting" on page 24 (E).

Note

"CLAMP" and "V-SHIFT" are not displayed when the input signal is video.

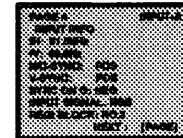

The signal input conditions are displayed.
fH: Horizontal frequency of the input signal
fV: Vertical frequency of the input signal

You can confirm "POS (positive)" or "NEG (negative)" for following settings:

("—" indicates that no synchronization signal is input to the projector.)

H/C-SYNC: Polarity of the H/C-SYNC

V-SYNC: Polarity of the V-SYNC

SYNC ON G: Polarity of the SYNC on the Green

- When POS (NEG) is displayed in green:
 The picture is being projected using its sync signal.
- When POS (NEG) is displayed in white:
 The picture is being projected without using its sync signal.

INPUT SIGNAL: Current input signal

Y/C: S video input signal from the optional IFB-1000 (when installing the optional IFB-1000 to the projector)

RGB: RGB input signal

NTSC: NTSC input signal from the optional IFB-1000 (when installing the optional IFB-1000 to the projector)

PAL: PAL input signal from the optional IFB-1000 (when installing the optional IFB-1000 to the projector)

SECAM: SECAM input signal from the optional IFB-1000 (when installing the optional IFB-1000 to the projector)

B & W: Black and white input signal from the optional IFB-1000 (when installing the optional IFB-1000 to the projector)

Internal oscillation: Internal oscillation mode (No signal is input.)

IDTV: Input signal from the optional IFB-3000 (when installing the optional IFB-3000 to the projector)

HDTV: Input signal from the optional IFB-1300 (when installing the optional IFB-1300 to the projector)

COMPONENT: Input signal from the optional IFB-1200 (when installing the optional IFB-1200 to the projector)

REGI BLOCK: The registration memory block number to which the input signal is assigned.

Projecting

Adjusting the Size and Shift of the Picture

If necessary, adjust the size and shift of the picture using the RGB SIZE/SHIFT and arrow keys.

You can also adjust the size of the picture input from the connectors of the IFB-1000 using the RGB SIZE and arrow keys. You cannot adjust the shift of the picture input from the connectors of the IFB-1000.

If you wish to store the current adjustment setting, press the MEMORY key. (For details, see "Storing the Setting Levels" on page 22 (E).)

After the setting is stored in the memory, the display disappears.

RGB/VIDEO SIZE adjustment

If the size of the picture does not fit the screen, adjust RGB SIZE. In this case, the RGB signal is input.

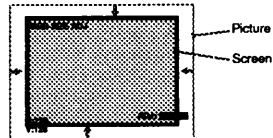

- 1 Press the RGB SIZE key.
- 2 Adjust by pressing the arrow keys until the picture fits the screen.
 - ◀: Reduces horizontal size.
 - ▶: Expands horizontal size.
 - ▲: Expands vertical size.
 - ▼: Reduces vertical size.

RGB SHIFT adjustment

If the RGB picture needs to be shifted on the screen, adjust RGB SHIFT.

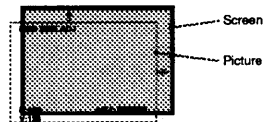

- 1 Press the RGB SHIFT key.
- 2 Adjust by pressing the arrow keys so that the picture fits the screen.

The picture shifts according to the direction of the arrow.

Resetting the Size/Shift to the Factory Preset Condition

- 1 Press the RGB SIZE or SHIFT key.
- 2 Press the ◀ and ▶ keys simultaneously.

The following on-screen display appears on the screen. (eg. To reset the RGB SIZE to the factory preset condition)

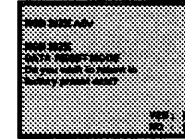

- 3 Press the ▲ key.

The following on-screen display appears on the screen to confirm that resetting has been completed.

To keep the current setting instead of resetting, press the ▼ key.

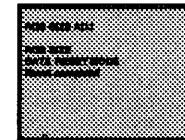

Projecting

Storing the Setting Levels

If you wish to store the adjusted settings, you can store them in memory. The following settings can be stored:

- COLOR TEMPERATURE, CLAMP, and V-SHIFT adjustment settings on PAGE 3
- VIDEO and RGB SIZE adjustment levels
- RGB SHIFT adjustment level

After the adjustment, press the MEMORY key.

The following on-screen display appears and storing starts. While the display is on, no other key will function.

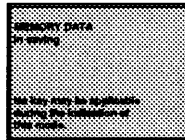

The following on-screen display appears to confirm that the setting adjustment has been completed.

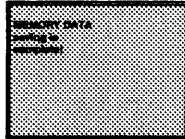

Screen Messages

Color codes

Four colors are used in the letters of on-screen display.

Color	Meaning
Green	Function and condition, item being selected on PAGE display
Cyan	Operating guide and messages
Yellow	Caution and error messages
White	Item being adjusted, item not being selected on PAGE display

Error Messages

When an error occurs, the following messages will appear.

Messages	Meaning
Not applicable!	The key does not function in the current mode.
PIC MUTING	Picture muting mode is on. If you wish to adjust the picture controls, press the PJ MUTING PIC key to cancel the PIC MUTING mode.
Overflow!	The setting is outside the adjustable range limits.
NO INPUT	No signal has been received.
OFF	On-screen display STATUS is set to OFF. To restore the on-screen display, press the STATUS ON key.

Correcting the Luminance of the Picture -- Clamp Setting

Clamp is used as a standard for setting the black level of the picture correctly. The standard position of the clamp depends on the kind of the sync signal. Normally, the CPU judges the signal and sets the clamp position automatically. However, the CPU may misjudge the signal because of noise. If the luminance of the picture seems to be incorrect, (too dark, the black color is too light, or the luminance is unstable) the clamp position may need to be changed. Change the clamp position following the procedure below.

- 1 Press the PAGE key repeatedly until the PAGE 3 appears.

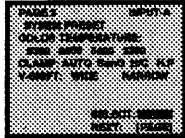

- 2 Select the clamp position by pressing the ◀, ▶, ▲ and ▼ keys.
 AUTO: Automatic setting mode. Normally, set to this position.
 S on G: If the black color is too light or seems to be green, set to this position.
 H/C: If the picture is too dark or the luminance is unstable, set to this position.
 H. P: If the luminance is still incorrect after changing the clamp setting to "S on G" or "H/C", set to this position and perform H-SHIFT adjustment.
- 3 Press the MEMORY key to store the adjustment data.

If the luminance is still incorrect after changing the clamp setting

There may be a problem with the input signal or the connection. Check the input signal.

Centering Adjustment

The three colors, red, green, and blue must converge for correct projection. If they do not converge, centering adjustment is necessary.

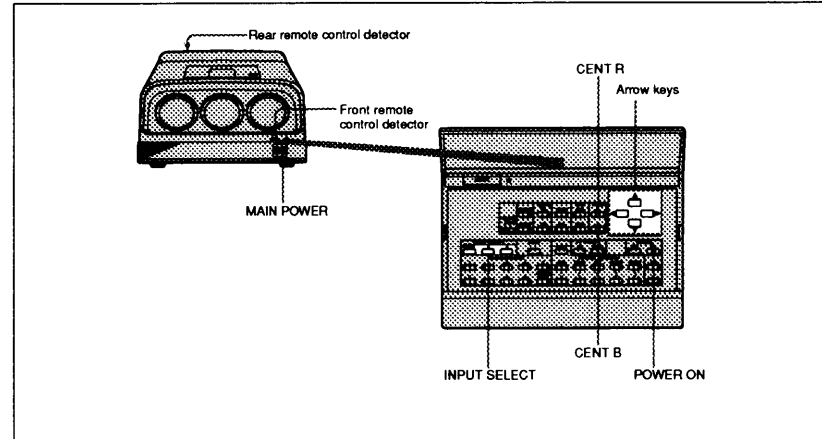

- 1 Turn the projector on by switching on the MAIN POWER switch and pressing the POWER ON key of the remote control.
- 2 Press the CENT R key. The built-in cross-hair test pattern appears and the red line will be adjustable.

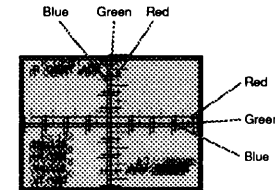

(Continued)

Centering Adjustment

- 3** Press the arrow keys to move the red line until the red and green lines converge and become yellow.

The red line moves according to the direction of the arrow.

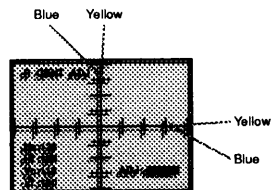

- 4** Press the CENT B key.

The blue line will be adjustable.

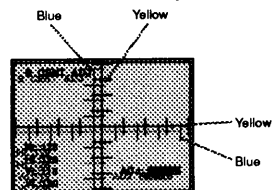

- 5** Press the arrow keys to move the blue line until the blue and yellow lines converge.

When all three color lines converge, the test pattern will become white.

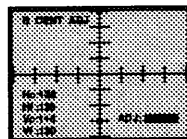

- 6** Press the MEMORY key.

The normal display is restored.

Installation Diagrams

Installation and preliminary adjustments should be carried out by Qualified Sony Personnel.

Installation 1 Floor, Flat Screen

Be sure that the projector is parallel to the floor.

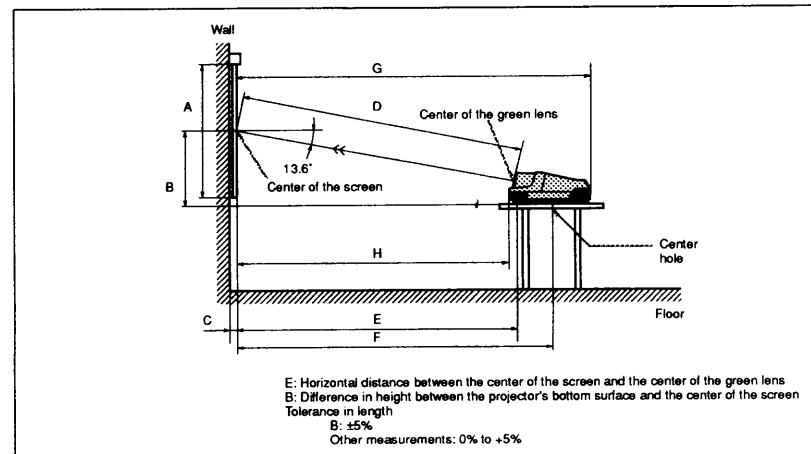

Unit:mm (inches)

Screen size (inches)	90	100	120	150	180	200	250	300
A (Vsize)	1372 (54 1/8)	1524 (60)	1829 (72 1/8)	2286 (90)	2743 (108)	3048 (120)	3810 (150)	4572 (180)
B (Hcent)	886 (35)	947 (37 3/8)	1071 (42 1/4)	1285 (50 5/8)	1485 (58 1/2)	1618 (63 3/4)	1939 (76 3/8)	2284 (90)
C (Width)		28 ^{a)} (1 1/8)	32 ^{b)} (1 3/8)					
D (TD)	2587 (101 7/8)	2847 (112 1/8)	3373 (132 7/8)	4285 (168 3/4)	5137 (202 1/4)	5702 (224 1/2)	7065 (278 1/4)	8533 (336)
E (Xlens)	2514 (99)	2767 (109)	3278 (129 1/8)	4165 (164)	4993 (196 1/8)	5542 (218 1/4)	6867 (270 3/8)	8294 (326 5/8)
F (L.Hole)	2762 (108 3/4)	3015 (118 3/4)	3526 (138 7/8)	4412 (173 3/4)	5240 (206 3/8)	5790 (228)	7114 (280 1/8)	8541 (336 3/8)
G (L.max)	3446 (135 3/4)	3699 (145 3/4)	4210 (165 7/8)	5097 (200 3/4)	5925 (233 3/8)	6474 (255)	7799 (307 1/8)	9226 (363 1/4)

^{a)} Sony VPS-100FH

^{b)} Sony VPS-120FH

Installation Diagrams

Installation 2 Ceiling, Flat Screen

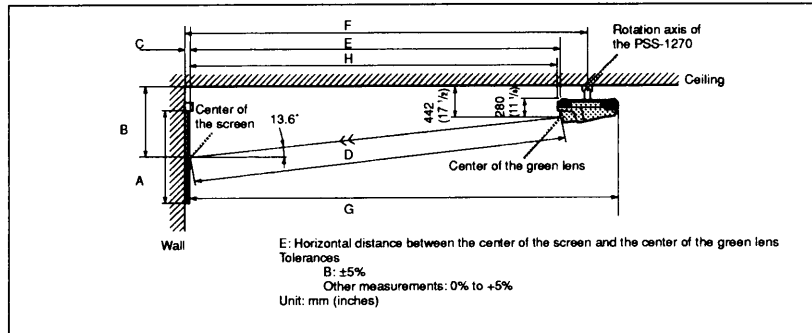

Unit: mm (inches)

Screen size (inches)	90	100	120	150	180	200	250	300
A (Vsize)	1372 (54 1/8)	1524 (60)	1829 (72 1/8)	2286 (90)	2743 (108)	3048 (120)	3810 (150)	4572 (180)
B (Hcent)	1048 (41 3/8)	1109 (43 3/8)	1233 (48 3/8)	1447 (57)	1647 (64 7/8)	1780 (70 1/8)	2101 (82 3/4)	2446 (96 3/8)
C (Width)		28 ^{a)} (1 1/8)	32 ^{a)} (1 1/4)					
D (TD)	2587 (101 7/8)	2847 (112 1/8)	3373 (132 7/8)	4285 (168 3/4)	5137 (202 1/4)	5702 (224 1/2)	7065 (278 1/4)	8533 (336)
E (Xlens)	2514 (99)	2767 (109)	3278 (129 7/8)	4165 (164)	4993 (196 5/8)	5542 (218 1/4)	6867 (270 3/8)	8294 (326 3/8)
F (L.Hole)	2787 (109 3/4)	3040 (119 3/4)	3551 (139 7/8)	4437 (174 3/4)	5265 (207 3/8)	5815 (229)	7139 (281 1/8)	8566 (337 1/4)
G (Lmax)	3446 (135 3/4)	3699 (145 3/4)	4210 (165 7/8)	5097 (200 3/4)	5925 (233 3/8)	6474 (255)	7799 (307 1/8)	9226 (363 1/4)

^{a)} Sony VPS-100FH

^{b)} Sony VPS-120FH

System Connections

Notes on connection

- First make sure that the power to each piece of equipment is turned off.
- Use appropriate cables for connecting the equipment.
- Cable connectors should be fully inserted into the jacks. A loose connection may cause hum and noise.
- To disconnect a cable, pull it out by the plug. Never pull the cable itself.
- Read the Operating Instructions of the equipment to be connected.

Connecting Directly to the Projector

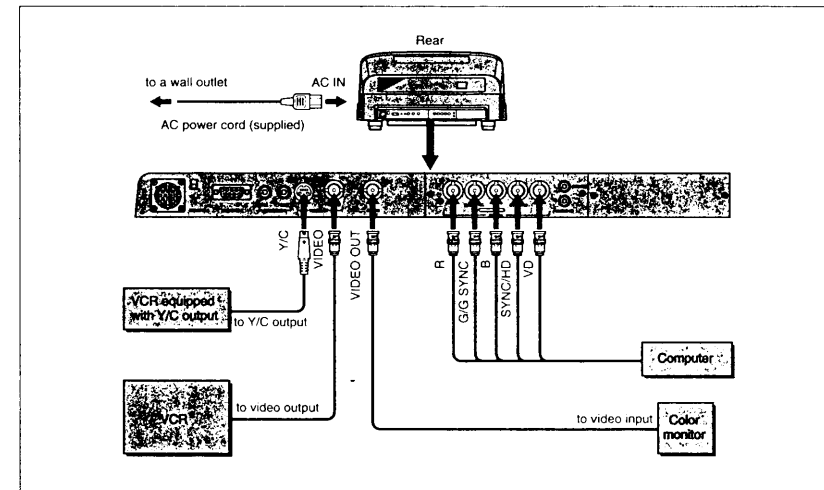

Notes

- The VIDEO connector is disconnected automatically when a cable is connected to the Y/C connector.
- The external sync signal has priority over the internal sync signal. However, when the external sync signal is not stable, the internal sync signal has priority.
- Do not project a still picture from a computer or video disc player for more than an hour.
- The dimensions of the character display area may vary or the picture may not be centered, depending on the computer being used. This does not mean that there is a fault in the projector.
- If your computer is equipped with a composite video output, connect it to the VIDEO IN connector on the projector.
- If necessary, adjust the size and shift of the picture using the RGB SIZE/SHIFT keys and arrow keys.
For details, see "Adjusting the Size and Shift of the Picture" on page 20 (E).

System Connections

Notes on connection

- First make sure that the power to each piece of equipment is turned off.
- Use appropriate cables for connecting the equipment.
- Cable connectors should be fully inserted into the jacks. A loose connection may cause hum and noise.
- To disconnect a cable, pull it out by the plug. Never pull the cable itself.
- Read the Operating Instructions of the equipment to be connected.

Connecting Directly to the Projector

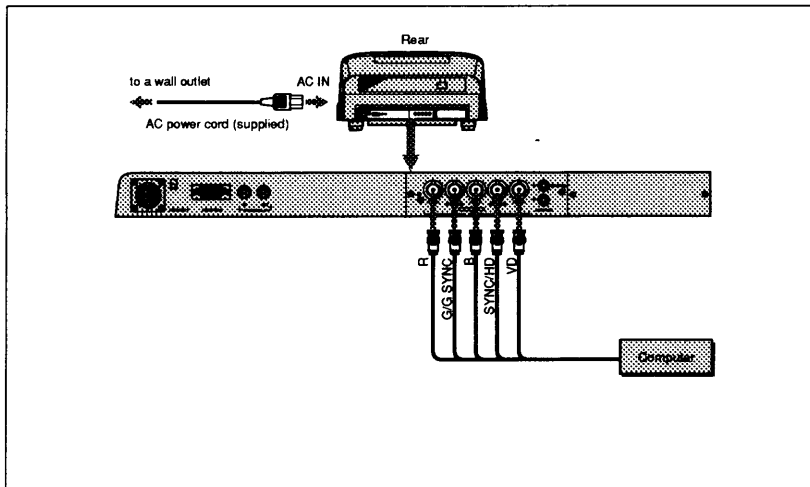

Notes

- The external sync signal has priority over the internal sync signal. However, when the external sync signal is not stable, the internal sync signal has priority.
- Do not project a still picture from a computer or video disc player for more than an hour.
- The dimensions of the character display area may vary or the picture may not be centered, depending on the computer being used. This does not mean that there is a fault in the projector.
- If necessary, adjust the size and shift of the picture using the RGB SIZE/SHIFT keys and arrow keys.

For details, see "Adjusting the Size and Shift of the Picture" on page 20 (E).

System Connections

Using an Interface Board

Use the optional IFB-11/20/30/1000/1200 or 1300 interface board to expand system connectivity.

Example: Using the IFB-20 Signal Interface Board

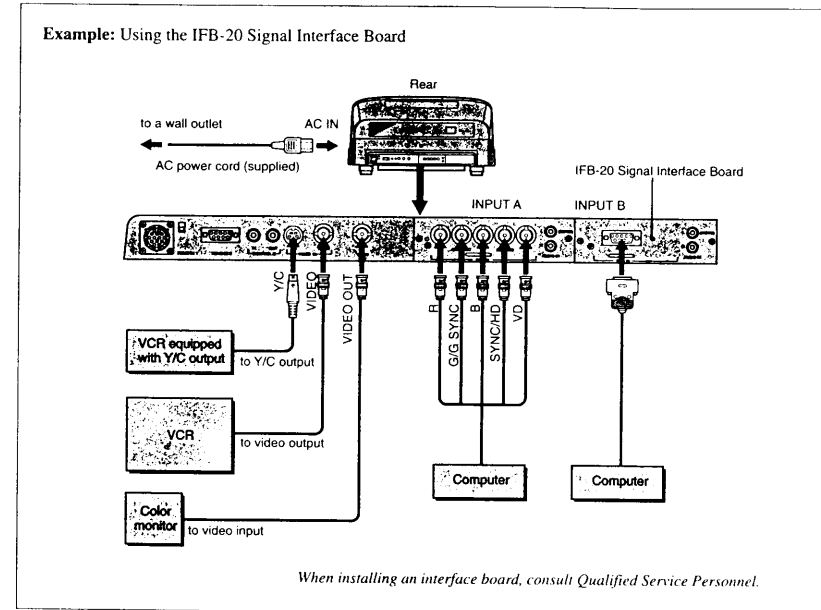

When installing an interface board, consult Qualified Service Personnel.

System Connections

Using an Interface Board

Use the optional IFB-11/20/30/1000/1200 or 1300 interface board to expand system connectivity.

Example: Using the IFB-20 Signal Interface Board

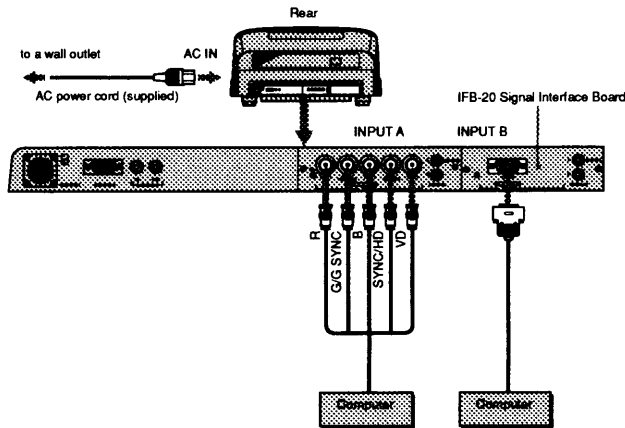

When installing an interface board, consult Qualified Service Personnel.

Using the Switcher

Use the optional PC-1271/1271M Signal Interface Switcher for connecting multiple video equipment. The input is selected by pressing the SWITCHER/INDEX keys on the remote control or the SWITCHER keys on the control panel of the projector.

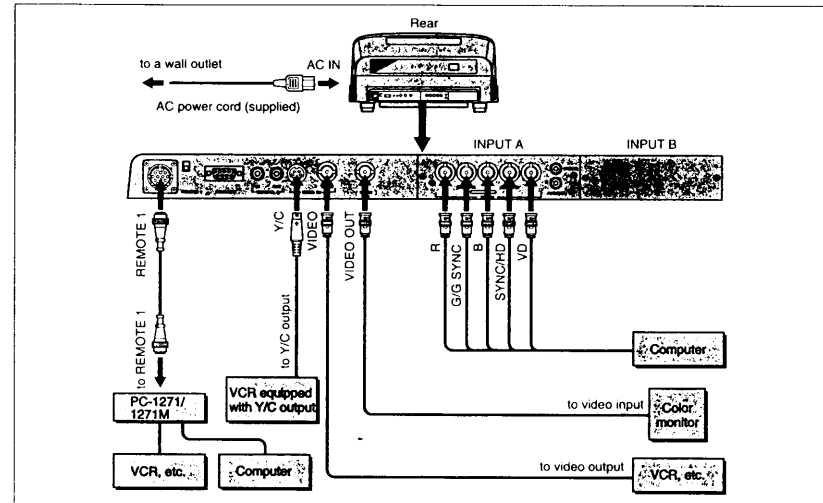

The equipment can be connected to the VIDEO IN, INPUT A and B connectors of the projector even when the switcher is connected.

Using the SWITCHER/INDEX keys on the remote control or the SWITCHER keys on the control panel of the projector

When using the remote control, set the SWITCHER/INDEX select switch to SWITCHER. Press a number key between 1 and 8 to select the input number of the switcher. When two switchers are connected, use the SECOND key. To control the second switcher (SINGLE/SECOND/OTHER switch on the switcher is set to SECOND), first press the SECOND key and then a number key.

14-pin connector

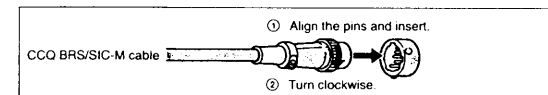

Using the Switcher

Use the optional PC-1271M Signal Interface Switcher for connecting multiple video equipment. The input is selected by pressing the SWITCHER/INDEX keys on the remote control or the SWITCHER keys on the control panel of the projector.

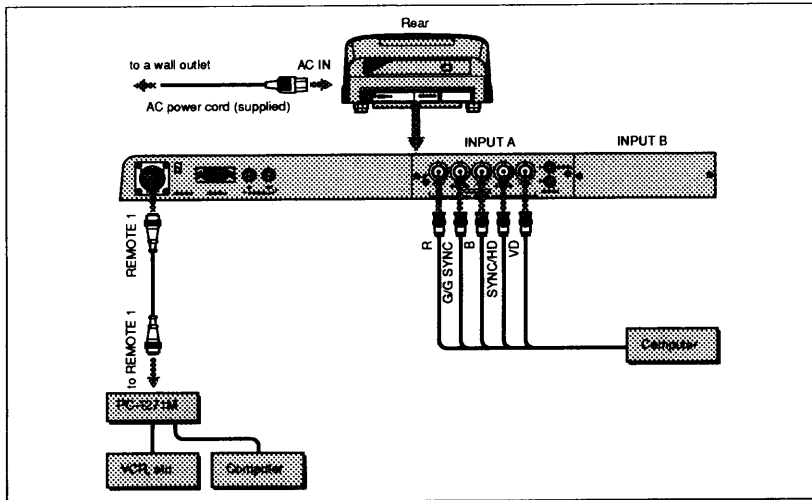

The equipment can be connected to the INPUT A and B connectors of the projector even when the switcher is connected.

Using the SWITCHER/INDEX keys on the remote control or the SWITCHER keys on the control panel of the projector

When using the remote control, set the SWITCHER/INDEX select switch to SWITCHER. Press a number key between 1 and 8 to select the input number of the switcher. When two switchers are connected, use the SECOND key. To control the second switcher (SINGLE/SECOND/OTHER switch on the switcher is set to SECOND), first press the SECOND key and then a number key.

14-pin connector

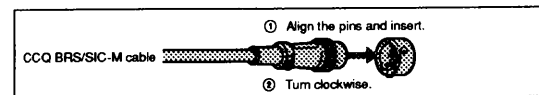

System Connections

When Projecting the High Resolution Pictures

When projecting the video signal which is above 70 MHz such as the computer graphics (CG), you should set the projector to the high resolution mode by switching the 5BNC switch.

To set the projector to the high resolution mode, set the 5BNC switch on the rear panel of the projector to 5BNC.

Then, connect the RGB IN connectors of the projector and the MONITOR OUT connectors of the switcher with five BNC cable.

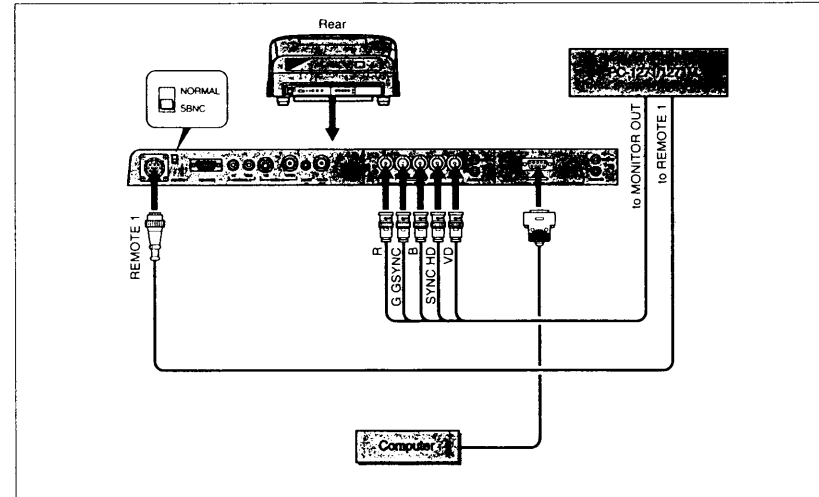

System Connections

When Projecting the High Resolution Pictures

When projecting the video signal which is above 70 MHz such as the computer graphics (CG), you should set the projector to the high resolution mode by switching the 5BNC switch. To set the projector to the high resolution mode, set the 5BNC switch on the rear panel of the projector to 5BNC. Then, connect the RGB IN connectors of the projector and the MONITOR OUT connectors of the switcher with five BNC cable.

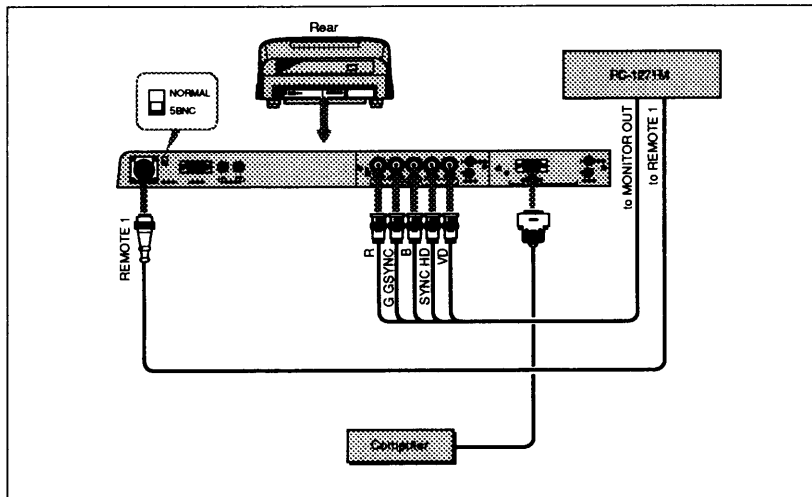

List of Messages

Use the list below to check the meaning of the messages displayed on the screen. The list is divided into sections depending on the location in the following diagram, then refer to the alphabetic listing to find the message.

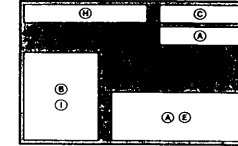

(B), (C), (D) and (A) listed below appear all over the screen.

A Caution messages

- | | |
|-----------------------|---|
| • Not applicable! | • The key does not function in the current mode. |
| • Overflow! | • The setting is outside the adjustable range limits. |
| • PIC MUTING | • Picture muting mode is on. |
| • Input is not VIDEO. | • The input signal is not VIDEO. |
| • Input is not NTSC. | • The input signal is not NTSC. |
| • Input is not RGB. | • The input signal is not RGB. |
| • Input is B & W. | • The input signal is black and white. |
| • OFF | • On-screen display STATUS is set to OFF. |
| • NO INPUT | • No signal has been received. |

B PIC CONTROL data

- | | |
|--------------------------|--------------------------------|
| • CONTR (CONTRAST) | • Contrast |
| • COLOR | • Color |
| • BRT (BRIGHTNESS) | • Brightness |
| • SHARP (SHARPNESS) | • Sharpness |
| • HUE | • Hue |
| • PIC CONTROL data reset | • Resets the PIC CONTROL data. |

C Input signal

- | | |
|-------------------------------------|---|
| • VIDEO | • Input from VIDEO IN |
| • INPUT-A | • Input from RGB IN |
| • INPUT-B | • Input from an optional interface board |
| • SW'ER x-y (switcher x=1-2, y=1-8) | • Input from an optional switcher |
| • ID No. xx | • The ID number of the optional IFB-101 (when the IFB-101 is installed) |
| • OTHER | • An optional switcher is in the OTHER mode. |

List of Messages

Use the list below to check the meaning of the messages displayed on the screen. The list is divided into sections depending on the location which the message appears. First check the location in the following diagram, then refer to the alphabetic listing to find the message.

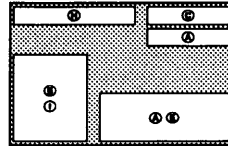

Ⓐ, Ⓑ, Ⓒ and Ⓓ listed below appear all over the screen.

A Caution messages

• Not applicable!	• The key does not function in the current mode.
• Overflow!	• The setting is outside the adjustable range limits.
• PIC MUTING	• Picture muting mode is on.
• Input is not VIDEO.	• The input signal is not VIDEO.
• Input is not NTSC.	• The input signal is not NTSC.
• Input is not RGB.	• The input signal is not RGB.
• Input is B & W.	• The input signal is black and white.
• OFF	• On-screen display STATUS is set to OFF.
• NO INPUT	• No signal has been received.

B PIC CONTROL data

• CONTR (CONTRAST)	• Contrast
• COLOR	• Color
• BRT (BRIGHTNESS)	• Brightness
• SHARP (SHARPNESS)	• Sharpness
• HUE	• Hue
• PIC CONTROL data reset	• Resets the PIC CONTROL data.

C Input signal

• INPUT-A	• Input from RGB IN
• INPUT-B	• Input from an optional interface board
• SW'ER x-y (switcher x=1-2, y=1-8)	• Input from an optional switcher
• ID No. xx	• The ID number of the optional IFB-101 (when the IFB-101 is installed)
• OTHER	• An optional switcher is in the OTHER mode.

List of Messages

D PAGE

Subtitle

• USER PRESET	• User preset
• USER CONTROL	• User control
• SYSTEM PRESET	• System preset
• INPUT INFO (INPUT INFORMATION)	• Input information

PAGE 1

• STATUS ON/OFF	• On-screen display on/off
• PIC MUTING ON/OFF	• Picture muting mode on/off

PAGE 2

• CONTR (CONTRAST)	• Contrast
• COLOR	• Color
• BRT (BRIGHTNESS)	• Brightness
• SHARP (SHARPNESS)	• Sharpness
• HUE	• Hue
• PIC CONTROL data reset	• Resets the PIC CONTROL data.

PAGE 3

• COLOR TEMPERATURE 9300/6500/5400/3200	• Color temperature is set to 9300/6500/5400/3200 manually adjusted by Qualified Sony Service Personnel.
• CLAMP: AUTO / S on G / H/C / H. P	• Clamp position is set to automatic/internal/external sync signal/ horizontal deflection pulse position.
• V-SHIFT: WIDE/NARROW	• The adjustable range of vertical shift is wide/narrow.

PAGE 4

• INPUT SIGNAL	• Input signal
• Y/C	• S video input signal from VIDEO IN
• RGB	• RGB input signal
• NTSC	• NTSC input signal from VIDEO
• PAL	• PAL input signal from VIDEO IN
• SECAM	• SECAM input signal from VIDEO IN
• B & W	• Black and white input signal from VIDEO IN
• IDTV	• IDTV input signal from the IFB-3000
• HDTV	• HDTV input signal from the IFB-1300
• COMPONENT	• COMPONENT input signal from the IFB-1200
• fH	• Horizontal frequency
• fV	• Vertical frequency
• Internal oscillation	• Internal oscillation mode (No signal is input.)

List of Messages

D PAGE

Subtitle

• USER PRESET	• User preset
• USER CONTROL	• User control
• SYSTEM PRESET	• System preset
• INPUT INFO (INPUT INFORMATION)	• Input information

PAGE 1

• STATUS ON/OFF	• On-screen display on/off
• PIC MUTING ON/OFF	• Picture muting mode on/off

PAGE 2

• CONTR (CONTRAST)	• Contrast
• COLOR	• Color
• BRT (BRIGHTNESS)	• Brightness
• SHARP (SHARPNESS)	• Sharpness
• HUE	• Hue
• PIC CONTROL data reset	• Resets the PIC CONTROL data.

PAGE 3

• COLOR TEMPERATURE 9300/6500/5400/3200	• Color temperature is set to 9300/6500/5400/3200 manually adjusted by Qualified Sony Service Personnel.
• CLAMP: AUTO / S on G / H/C / H. P	• Clamp position is set to automatic/internal/external sync signal/ horizontal deflection pulse position.
• V-SHIFT: WIDE/NARROW	• The adjustable range of vertical shift is wide/narrow.

PAGE 4

• INPUT SIGNAL	• Input signal
• Y/C	• S video input signal from the IFB-1000
• RGB	• RGB input signal
• NTSC	• NTSC input signal from the IFB-1000
• PAL	• PAL input signal from the IFB-1000
• SECAM	• SECAM input signal from the IFB-1000
• B & W	• Black and white input signal from the IFB-1000
• IDTV	• IDTV input signal from the IFB-3000
• HDTV	• HDTV input signal from the IFB-1300
• COMPONENT	• COMPONENT input signal from the IFB-1200
• FH	• Horizontal frequency
• FV	• Vertical frequency
• Internal oscillation	• Internal oscillation mode (No signal is input.)

• H/C-SYNC	• Horizontal sync signal or composite sync signal
• V-SYNC	• Vertical sync signal
• SYNC ON G	• Composite sync signal
• H/C-SYNC: POS/NEG/--	• The polarity of the H/C-SYNC is positive/negative/not input.
• V-SYNC: POS/NEG/--	• The polarity of the V-SYNC is positive/negative/not input.
• SYNC ON G: NEG/--	• The polarity of the SYNC ON G is negative/not input.
• REGI BLOCK: No. x	• The input signal is grouped into the registration memory block No. x.

E Operation

• YES: ▲	• Press ▲ for "Yes".
• NO: ▼	• Press ▼ for "No".
• SELECT: ◀▶	• Press ◀ or ▶ key to select.
• SELECT: ◀▶▲▼	• Press ◀, ▶, ▲ or ▼ key to select.
• ADJ: ◀▶▲▼	• Press ◀, ▶, ▲ or ▼ key to adjust.
• ADJ: ◀▶	• Press ◀ or ▶ key to adjust.
• ADJ: ▲▼	• Press ▲ or ▼ key to adjust.
• NEXT: [PAGE]	• Press PAGE key to go to the next page.
• EXIT: [PAGE]	• Press PAGE key to exit the PAGE mode.
• ENTER: ▶	• Press ▶ key to execute the selected item.
• ENTER: ▲	• Press ▲ key to execute the selected item.
• CANCEL: ▼	• Press ▼ key to cancel the setting.

F Memory data

• MEMORY DATA in saving	• Saving data in memory
• MEMORY DATA saving is complete!	• Saving data in memory is completed.
• No key may be applicable during the indication of this mode	• When in this mode (MEMORY DATA saving), no key functions.

G Data reset

• Do you wish to return to factory preset data?	• Do you wish to reset the data to the factory preset data?
• Do you wish to return to previously saved data?	• Do you wish to reset the data to the previously saved data?
• Reset complete!	• Resetting has been completed.
• RGB SIZE DATA RESET MODE	• RGB or video input size data resetting mode
• RGB SHIFT DATA RESET MODE	• RGB input shift data resetting mode

List of Messages

Adjustment

- | | |
|------------------------|---|
| • RGB SIZE ADJ | • RGB or video input size adjustment mode |
| • RGB SHIFT ADJ | • RGB input shift adjustment mode |
| • R CENT ADJ | • Red centering adjustment mode |
| • B CENT ADJ | • Blue centering adjustment mode |

Adjustment data

- | | |
|------------------|--|
| • H: xxx | • Horizontal adjustment level (xxx=MIN, 1, 2, ... 254, 255, MAX) |
| • V: xxx | • Vertical adjustment level (xxx=MIN, 1, 2, ... 254, 255, MAX) |
| • Hf: xxx | • Centering adjustment level for horizontal direction (xxx=MIN, 1, 2, ... 254, 255, MAX) Use the arrow keys to increment or decrement this number. |
| • Hc: xxx | • Centering adjustment level for horizontal direction (xxx=MIN, 1, 2, ... 254, 255, MAX) Use the arrow keys to increment or decrement this number. |
| • Vf: xxx | • Centering adjustment level for vertical direction (xxx=MIN, 1, 2, ... 254, 255, MAX) Use the arrow keys to increment or decrement this number. |
| • Vc: xxx | • Centering adjustment level for vertical direction (xxx=MIN, 1, 2, ... 254, 255, MAX) Use the arrow keys to increment or decrement this number. |

Others

- | | |
|---|--|
| • For optimum performance, white screen will remain for 20 min. For immediate use, push [PAGE] key. | • For optimum performance, white screen will remain for 20 min. For immediate use, press the PAGE key. |
|---|--|

Index

A

- Adjusting
 - centering 25 (E)
 - RGB SHIFT 20 (E)
 - RGB/VIDEO picture size 20 (E)

B

- Battery
 - installation 12 (E)
 - notes 12 (E)

C, D, E, F

- Carrying the projector 8 (E)
- Clamp setting 24 (E)
- Connecting
 - remote control to the projector 12 (E)
 - to external equipment directly 29 (E)
 - using the optional board 30 (E)
 - using the optional switcher 31 (E)
 - when projecting the high resolution pictures 32 (E)
- Correcting the luminance of the picture 24 (E)

G, H

- Grips 8 (E)
- Handles 8 (E)

I, J, K

- Initialization screen 13 (E)
- Inserting the grips 8 (E)
- Installation
 - ceiling installation 28 (E)
 - diagrams 27 (E), 28 (E)
 - floor installation 27 (E)

L, M

- List of messages 33 (E)

N, O

- Notes
 - for wireless remote control operation 11 (E)
 - on batteries 12 (E)
 - on projecting a picture input from the RGB IN connectors 15 (E)

P, Q

- PAGE 1 17 (E)
- PAGE 2 17 (E)
- PAGE 3 18 (E)
- PAGE 4 19 (E)
- Precautions 4 (E)
- Projection procedure 14 (E)

R

- Removing
 - grips 8 (E)
 - on-screen display 15 (E)
- Resetting
 - picture settings to the factory preset levels 16 (E)
 - size/shift to the factory preset condition 21 (E)

S

- Screen messages
 - color codes 23 (E)
 - error messages 23 (E)
- Side Handles 8 (E)
- Storing the setting levels 22 (E)

T

- Turning off the picture 15 (E)

U

- Using the side handles 8 (E)

1-2. INSTALLATION

Installation Procedures

By default, this projector is adjusted for 120-inch front projection on the floor/desk. If you install the projector in other conditions, you have to change some settings. Therefore, installation procedures depend on the screen size or type, and installation method.

- ① Verify the conditions of installation, such as angle of optical axis, projection distance, height of the projector and screen.
- ② Adjust the ring spacers. (page 18(E))
- ③ Install the projector and screen. (page 5(E))
- ④ Reset the cross-hatch to factory setting. (page 88(E))
- ⑤ Adjust the CRT conversion angle. (page 20(E))
- ⑥ Change the polarity according to the projection patterns. (page 22(E))
- ⑦ Adjust the lens focus, magnetic focus and AQP (Axis Quadrupole) / DQP (Diagonal Quadrupole). (page 48(E))
- ⑧ Adjust the registrations. (page 56(E))
- ⑨ Connect other equipment. (page 28(E))
- ⑩ Adjust the each input signal.
 - Fine adjustment for the magnetic focus and registrations. (pages 80(E) and 82(E))
 - Adjust the size or shift of the picture. (pages 81(E), 83(E) and 84(E))
 - Adjust the blanking. (pages 81(E) and 84(E))

Installation Diagrams

Necessary Clearance for Installation and Maintenance

When installing the projector, be sure to provide enough room for maintenance service, as illustrated below.

Front

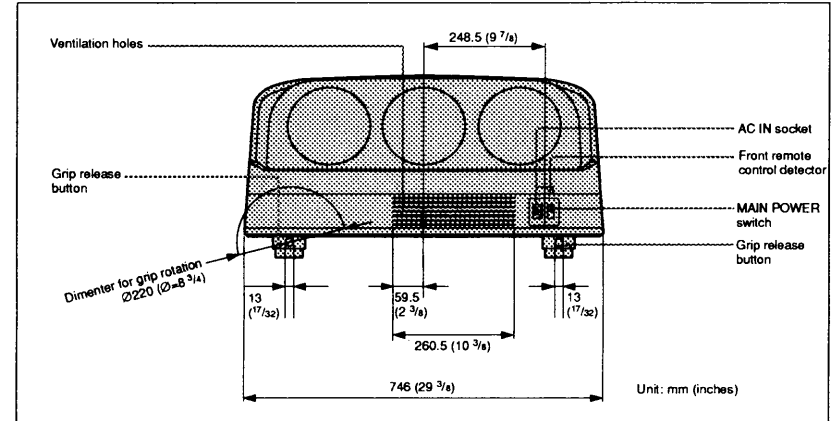

Rear

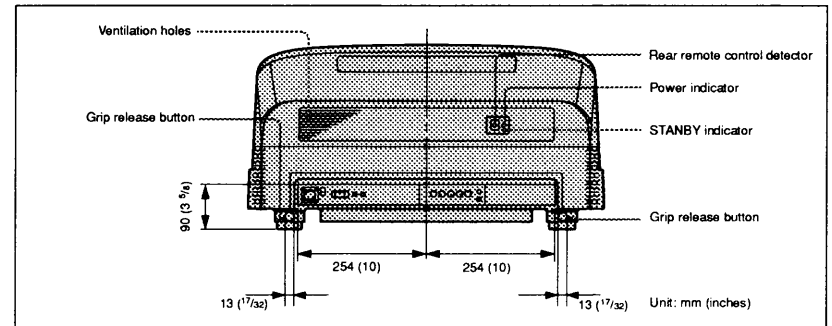

Installation Diagrams

Bottom

The center hole on the bottom surface is useful for reference when measuring for installation. For normal installation, use the seven holes to fix the projector.

Note

Use only the M8 metric screws (38mm (1 1/2 inches) to 42mm (1 11/16 inches) long) for the attachment holes. When using the optional PSS-1270 Projector Suspension Support, use the screws supplied with the projector.

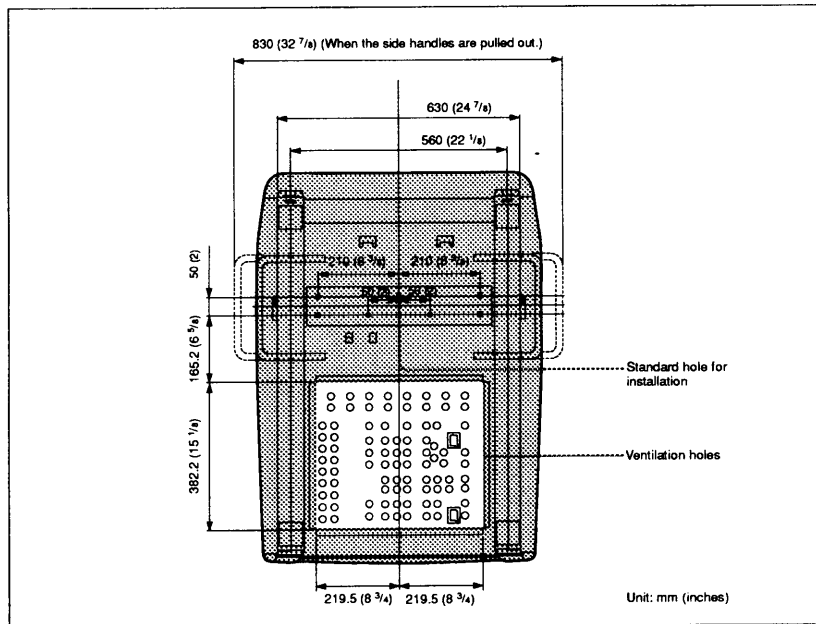

Side

Refer to the diagram below for installation.

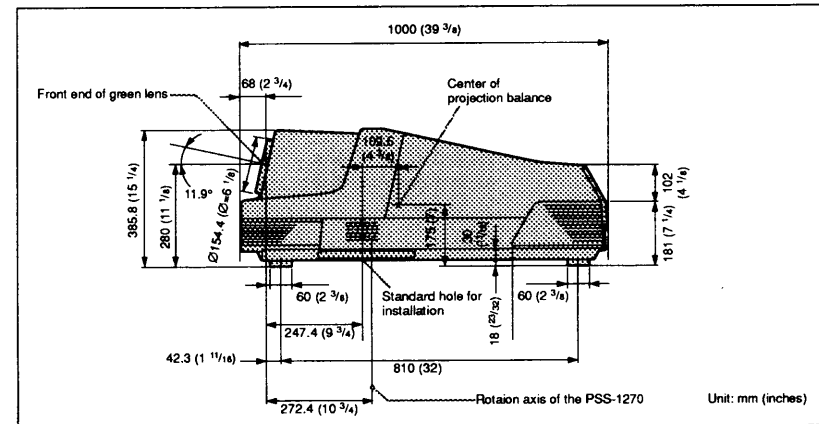

Installation Diagrams

Refer to the diagram below when removing the cover, carrying the projector with the grips and making clearance for the ventilation holes.

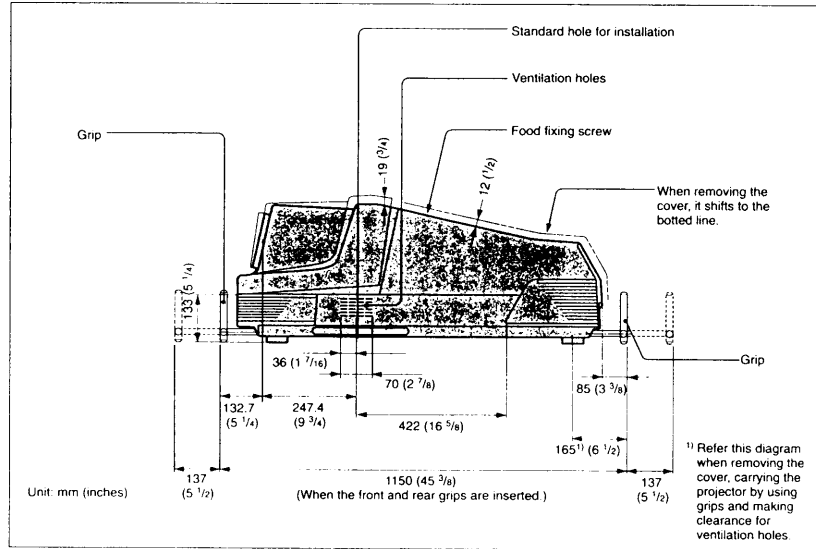

Carrying the projector

You can carry the projector by using the handle.

Using the side handles

Pull out to use. To put away the side handle, slide it backward.

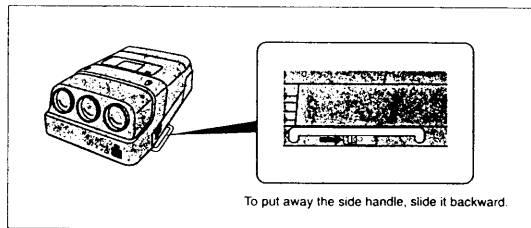

Installation Diagrams

Refer to the diagram below when removing the cover, carrying the projector with the grips and making clearance for the ventilation holes.

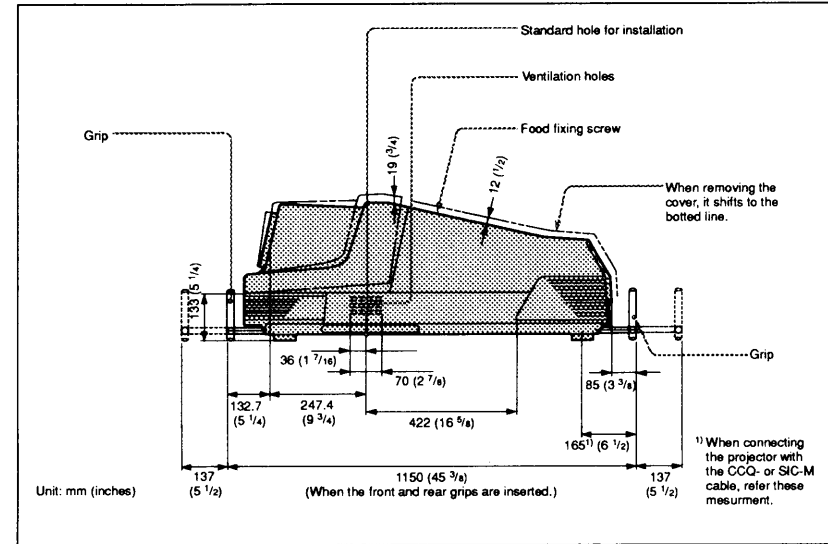

Carrying the projector

You can carry the projector by using the handle.

Using the side handles

Pull out to use. To put away the side handle, slide it backward.

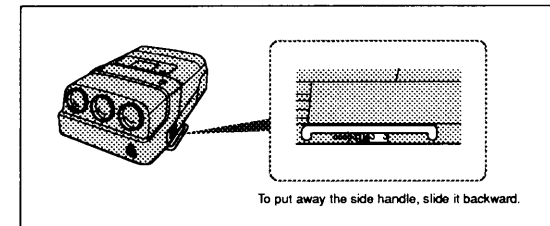

Inserting the front or rear grips

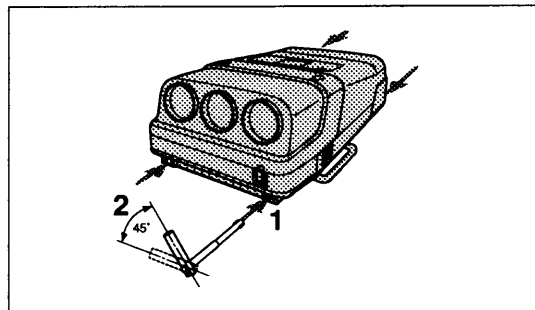

- 1 Insert the grip as illustrated above.
- 2 Turn the grip until it is fixed.

Removing the front or rear grips

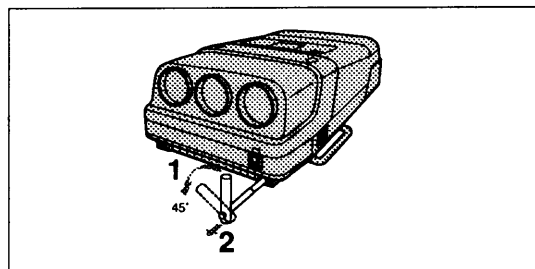

- 1 While pressing the grip release button, turn the grip until it is fixed.
- 2 Pull out the handle.

Installation Diagrams

Floor Installation Using Front Projection Flat Screen

Be sure that the projector is level to the floor.

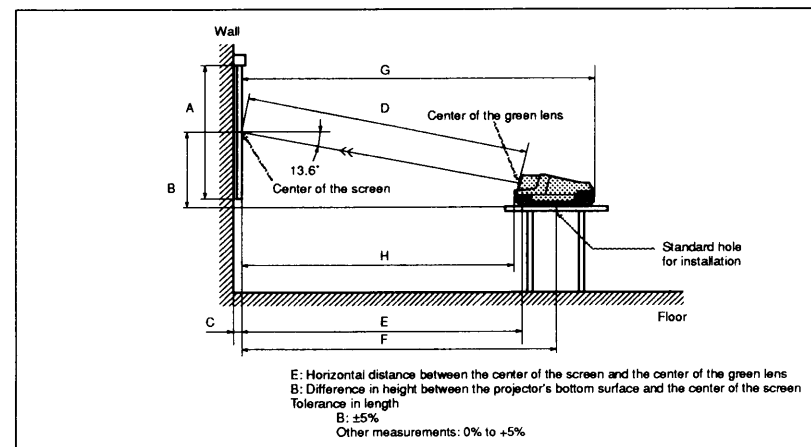

	Unit:mm (inches)							
Screen size (inches)	90	100	120	150	180	200	250	300
A (Vsize)	1372 (54 1/8)	1524 (60)	1829 (72 1/8)	2286 (90)	2743 (108)	3048 (120)	3810 (150)	4572 (180)
B (Hcent)	886 (35)	947 (37 3/8)	1071 (42 1/4)	1285 (50 5/8)	1485 (58 1/2)	1618 (63 3/4)	1939 (76 3/8)	2284 (90)
C (Width)	28 ^{a)} (1 1/8)		32 ^{b)} (1 5/16)					
D (TD)	2587 (101 7/8)	2847 (112 1/8)	3373 (132 7/8)	4285 (168 3/4)	5137 (202 1/4)	5702 (224 1/2)	7065 (278 1/4)	8533 (336)
E (Xlens)	2514 (199)	2767 (109)	3278 (129 1/8)	4165 (164)	4993 (196 5/8)	5542 (218 1/4)	6867 (270 3/8)	8294 (326 5/8)
F (L.Hole)	2762 (108 3/4)	3015 (118 3/4)	3526 (138 7/8)	4412 (173 3/4)	5240 (206 3/8)	5790 (228)	7114 (280 1/8)	8541 (336 5/8)
G (L.max)	3446 (135 3/4)	3699 (145 3/4)	4210 (165 3/8)	5097(200 3/4)	5925 (233 3/8)	6474 (255)	7799 (307 1/8)	9226 (363 1/4)
Spacer								
(Red - L)	-10	-9.5	-9	-8	-7.5	-7	-3.5	-13.5
(Red - C)	15.5	14.5	13.5	12.5	12.5	12.5	15	4
(Green - L)	-12.5	-12	-11	-10	-10	-9.5	-9	-9
(Green - C)	12.5	12	11	10	10	9.5	9	9
(Blue - L)	10	9.5	9	8	7.5	7	3.5	13.5
(Blue - C)	-15.5	-14.5	-13.5	-12.5	-12.5	-12.5	-15	-4

^{a)} Sony VPS-100FH

^{b)} Sony VPS-120FH

Installation Diagrams

Ceiling Installation Using Front Projection Flat Screen

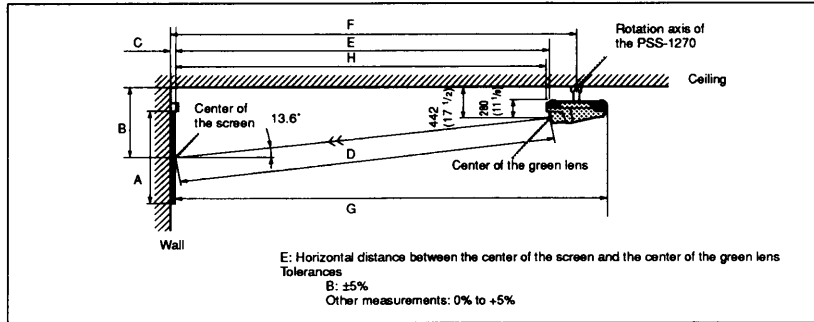

	Unit:mm (inches)							
Screen size (inches)	90	100	120	150	180	200	250	300
A (Vsize)	1372 (54 1/8)	1524 (60)	1829 (72 1/8)	2286 (90)	2743 (108)	3048 (120)	3810 (150)	4572 (180)
B (Hcent)	1048 (41 3/8)	1109 (43 3/8)	1233 (48 3/8)	1447 (57)	1647 (64 7/8)	1780 (70 1/8)	2101 (82 3/8)	2446 (96 3/8)
C (Width)	28 ^ø (1 1/8)		32 ^ø (1 3/8)					
D (TD)	2587 (101 7/8)	2847 (112 1/8)	3373 (132 7/8)	4285 (168 3/4)	5137 (202 1/4)	5702 (224 1/2)	7065 (278 1/4)	8533 (336)
E (Xlens)	2514 (99)	2767 (109)	3278 (129 1/8)	4165 (164)	4993 (196 1/8)	5542 (218 1/4)	6867 (270 3/8)	8294 (326 1/8)
F (LHole)	2787 (109 3/4)	3040 (119 3/4)	3551 (139 1/8)	4437 (174 3/4)	5265 (207 3/8)	5815 (229)	7139 (281 1/8)	8566 (337 1/4)
G (Lmax)	3446 (135 3/4)	3699 (145 3/4)	4210 (165 3/4)	5097 (200 3/4)	5925 (233 3/8)	6474 (255)	7799 (307 1/8)	9226 (363 1/4)
Spacer								
(Red - L)	-10	-9.5	-9	-8	-7.5	-7	-3.5	-13.5
(Red - C)	15.5	14.5	13.5	12.5	12.5	12.5	15	4
(Green - L)	-12.5	-12	-11	-10	-10	-9.5	-9	-9
(Green - C)	12.5	12	11	10	10	9.5	9	9
(Blue - L)	10	9.5	9	8	7.5	7	3.5	13.5
(Blue - C)	-15.5	-14.5	-13.5	-12.5	-12.5	-12.5	-15	-4

- 1) Sony VPS-100FH
- 2) Sony VPS-120FH

Necessary parts modifications

Changing the polarity on the L and ED board.
 For details, see "Changing the Polarity" on page 22 (E).

When the Screen Size is not Mentioned in the Tables

You can calculate the installation measurements with the tables on pages 102 (E) to 113 (E) (nonstandard installation) when you use the screen whose size is not mentioned in the tables on pages 10 (E), 11 (E) and 13 (E).

About the installation measurements

Check your installation conditions:

- Screen size (S)
- Installation measurements in the tables both for larger screen size (EL) and for smaller one (ES)

See the tables on pages 102 (E) to 113 (E).

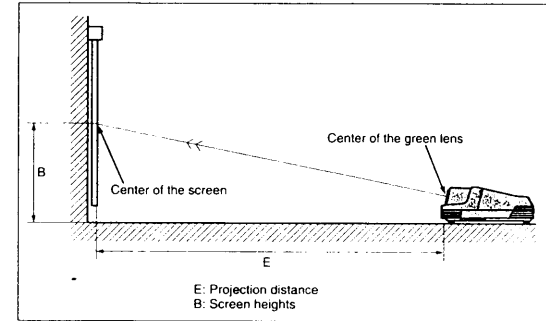

Now you can calculate the installation measurements as follows:

$$E \text{ (mm)} = ES + ((S - \text{smaller screen size}) \times (EL - ES) \times 0.1)$$

$$B \text{ (mm)} = E \times 0.241 + 280$$

Example: when using 124-inch screen

According to the tables on page 104 (E), the values ES and EL are as follows:

- ES = 3279 (As the smaller screen size is 120 inch.)
- EL = 3570 (As the larger screen size is 130 inch.)

Therefore,

$$E \text{ (mm)} = 3279 + ((124 - 120) \times (3570 - 3279) \times 0.1) = 3395 \text{ (mm)}$$

$$B \text{ (mm)} = 3395 \times 0.241 + 280 = 1098 \text{ (mm)}$$

Note

With nonstandard installation, the optical axis angle (TA) is fixed as follows:

- When using the front projection screen: 13.6° (B/E = 0.2419)
- When using the front projection screen: -2° (B/E = -0.0349)

Installation Diagrams

When the Screen Size is not Mentioned in the Tables

You can calculate the installation measurements with the tables on pages 102 (E) to 113 (E) (nonstandard installation) when you use the screen whose size is not mentioned in the tables on pages 10 (E), 11 (E) and 13 (E).

About the Installation measurements

Check your installation conditions:

- Screen size (S)
 - Installation measurements in the tables both for larger screen size (EL) and for smaller one (ES)
- See the tables on pages 102 (E) to 113 (E).

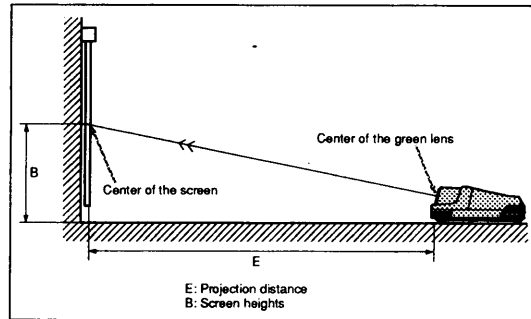

Now you can calculate the installation measurements as follows:
 $E \text{ (mm)} = ES + ((S - \text{smaller screen size}) \times (EL - ES) \times 0.1)$
 $B \text{ (mm)} = E \times 0.241 + 280$

Example: when using 124-inch screen

According to the tables on page 104 (E), the values ES and EL are as follows:

- ES = 3279 (As the smaller screen size is 120 inch.)
- EL = 3570 (As the larger screen size is 130 inch.)

Therefore,

$E \text{ (mm)} = 3279 + ((124 - 120) \times (3570 - 3279) \times 0.1) = 3395 \text{ (mm)}$
 $B \text{ (mm)} = 3395 \times 0.241 + 280 = 1098 \text{ (mm)}$

Note

- With nonstandard installation, the optical axis angle (TA) is fixed as follows:
- When using the front projection screen (floor installation): 13.6° (B/E = 0.2419)
 - When using the front projection screen (ceiling installation): -2° (B/E = -0.0349)

Floor Installation Using Rear Projection Flat Screen

What is the optical axis angle?

The optical axis angle is the angle between the horizontal level line and the straight line from the center of the projector's green lens to the center of the screen. When using a rear projection screen, you can get the brightest picture when the center of the screen is aligned with a straight line extension of the center of the green lens.

Therefore, the most suitable optical axis angle (a) varies depending on the height of the screen and your line of sight.

With the standard installation, set up the projector and screen such that this angle is between 0° and 2°.

When the optical axis angle is 2°

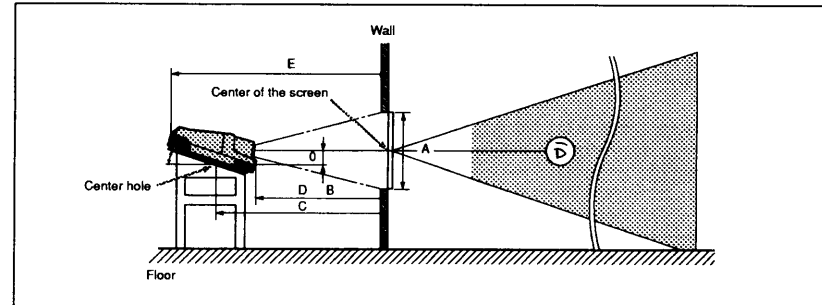

Unit: mm (inches)

Screen size (inches)	90	100	120	150	180	200	250	300
A (Vsize)	1372 (54 1/8)	1524 (60)	182 (72 1/8)	2286 (90)	2743 (108)	3048 (120)	3810 (150)	4572 (180)
B (Hcent)	102 (4 1/8)	93 (3 3/4)	74 (3)	43 (1 3/4)	13 (1/2)	-6 (-1/4)	-53 (-2 1/8)	-104 (-4 1/8)
C (Lhole)	2873 (113 1/8)	3132 (123 3/8)	3653 (143 3/8)	4558 (179 1/2)	5402 (212 3/4)	5964 (234 1/8)	7316 (288 1/8)	8772 (345 3/8)
D (Xlens)	2567 (101 1/8)	2826 (111 3/8)	3348 (131 3/8)	4252 (167 1/2)	5097 (202 3/4)	5659 (222 7/8)	7011 (276 1/8)	8467 (333 3/8)
E (Lmax)	3535 (139 1/4)	3794 (149 1/2)	4316 (170)	5220 (205 3/8)	6065 (238 7/8)	6627 (261)	7979 (314 1/8)	9435 (371 1/2)
Spacer								
(Red - L)	3	3.5	4.5	5.5	6	6	-7.5	-7.5
(Red - C)	-9	-9	-8.5	-8	-8	-8	6.5	6.5
(Green - L)	-6	-6.5	-6.5	-7	-7	-7	-7	-7
(Green - C)	6	6.5	6.5	7	7	7	7	7
(Blue - L)	-3	-3.5	-4.5	-5.5	-6	-6	7.5	7.5
(Blue - C)	9	9	8.5	8	8	8	-6.5	-6.5

Necessary parts modifications

Changing the polarity on the L and ED board.

For details, see "Changing the Polarity" on page 22 (E).

Installation Diagrams

Variable Range of the Optical Axis Angle in Rear Projection

You can adjust the optical axis angle by using the ring spacers.

On floor installation

You can install the projector within an angle of optical axis +2° to -13.6°.

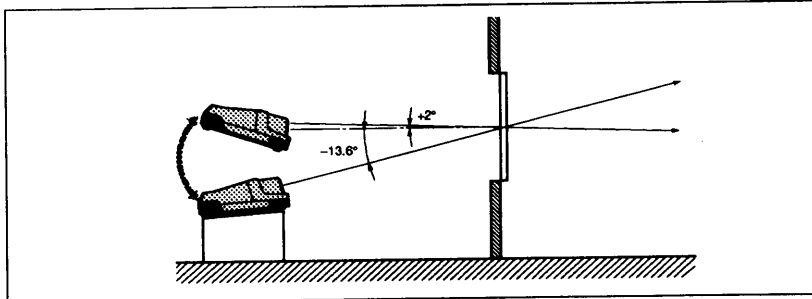

On ceiling installation

You can install the projector within an angle of optical axis +3° to +13.6°.

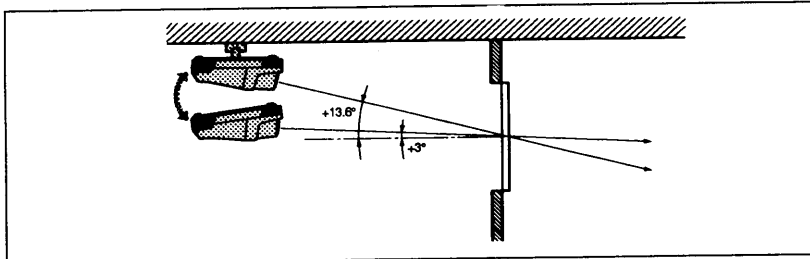

Notes on Screen

Screen Size

The screen size is the diagonal length of the screen in inches, while the aspect ratio of the screen is 4:3. The ratio of the screen height, width, and diagonal is 3:4:5. If you use a screen whose size is not given in the table below, you can calculate the screen height and width from the screen size (inches) as follows.

$$\text{Height (mm)} = \text{Screen size} \times 25.4 \times \frac{3}{5}$$

$$\text{Width (mm)} = \text{Screen size} \times 25.4 \times \frac{4}{5}$$

Screen size and dimensions

Screen size (Inches) (Diagonal)	Height (mm)	Width (mm)
100	1524	2032
120	1829	2438
150	2286	3048
180	2743	3658
200	3048	4064
250	3810	5080
300	4572	6096

Screens with an Aspect Ratio Other Than 4:3

When the height is greater

Calculate the approximate screen size from the screen height as shown below. Install the projector and screen in accordance with the screen size obtained.

--- : Screen whose aspect ratio is 4:3

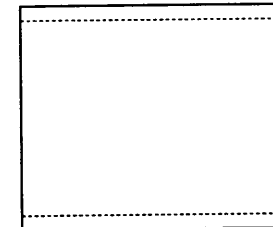

$$\text{Screen size (inch)} = (\text{height (mm)} \times \frac{5}{3}) \times \frac{1}{25.4}$$

Example: When the screen height is 1500 mm
 $(1500 \text{ (mm)} \times \frac{5}{3}) \times \frac{1}{25.4} = 98 \text{ inches}$

Installation Diagrams

When the width is greater

Calculate the approximate screen size from the screen width as shown below. Install the projector and screen in accordance with the screen size obtained.

---: Screen whose aspect ratio is 4:3

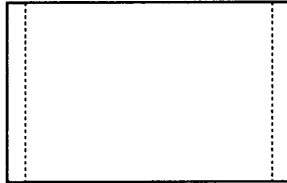

Screen size (inch) = (height (mm) \times $\frac{5}{4}$) \times $\frac{1}{25.4}$

Example: When the screen height is 2000 mm
 (2000 (mm) \times $\frac{5}{4}$) \times $\frac{1}{25.4}$ = 98 inches

Types of Screen

Front projection screen for floor installation

The bead screen is recommended. A screen of this type reflects the brightest light.

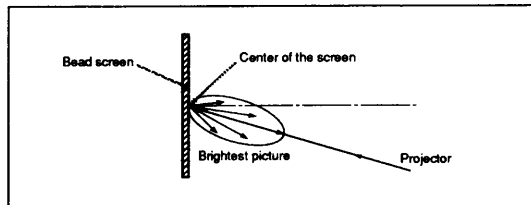

Front projection screen for ceiling installation

The silver screen is recommended. You can get a picture that is two to four times brighter.

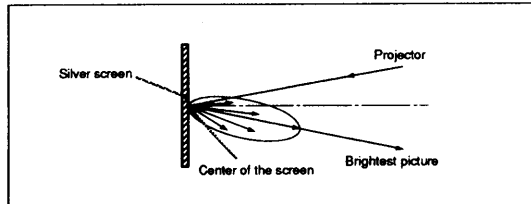

Rear projection screen

A screen manufactured using two sheets, the fresnel and lenticular, is recommended for a bright and clear full-screen picture projection.

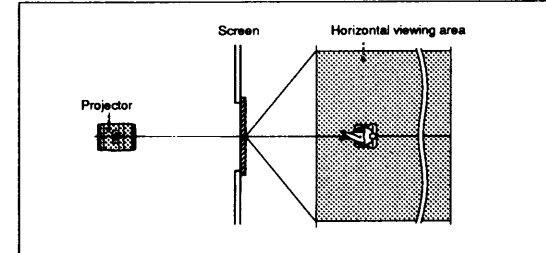

White screen

When viewers watch the projected picture in a wide area, you can obtain a picture that appears equally bright from all parts of the room using the white screen for both floor and ceiling installations. Note that you will not be able to get a clear picture in this case unless the room is dark.

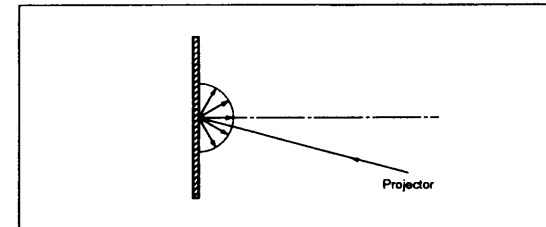

Modifying Parts

Removing the Front Cover

- 1 Turn off the main power.
- 2 Unlock the two screws on the projector by using a screwdriver or a coin edge, and then remove the front cover.

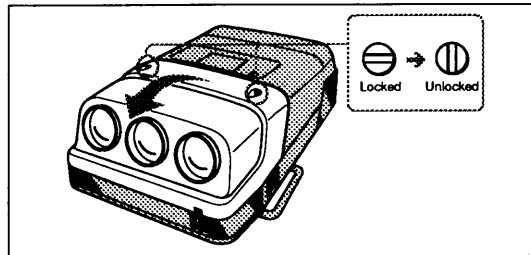

Changing the Ring Spacers

Adjust the ring spacers in accordance with the screen size and optical axis angle.
For the value of the appropriate ring spacers, see the table on pages 102 (E) to 113 (E).

To adjust the ring spacers, follow the procedure below.

- 1 Remove the front cover.
- 2 Loosen the spacer fixing screws of the green CRT.

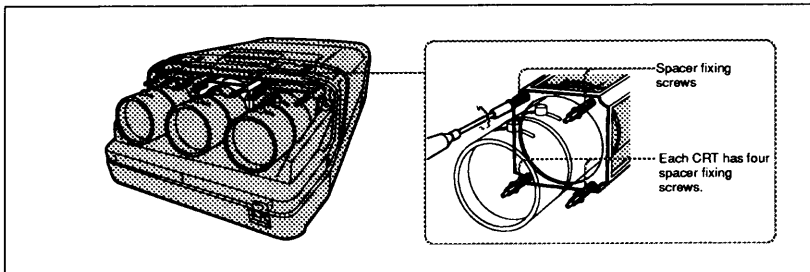

- 3 Rotate the ring spacer C of the green CRT until the appropriate value is set to pointer.

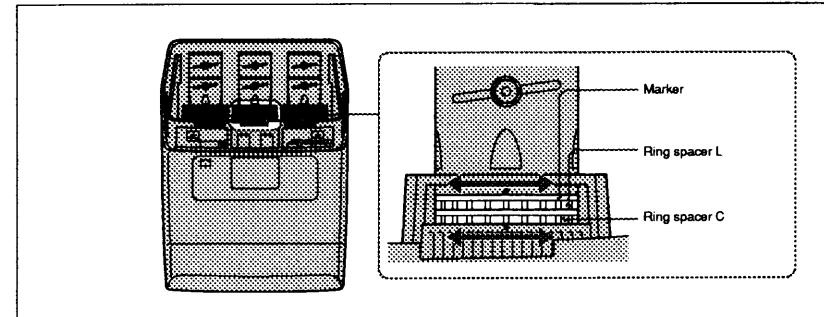

- 4 Rotate the ring spacer L of the green CRT until the appropriate value is in the marker.
- 5 Push in and tighten the spacer fixing screws.
- 6 Repeat steps 2 to 5, until you adjust the ring spacer C and L for the red and blue CRTs.
- 7 Replace the front cover.

Modifying Parts

Adjusting the CRT Conversion Angle

Adjust the CRT conversion angle so that the three CRT images converge exactly. This adjustment is for the red and blue CRTs.

- 1 Remove the front cover.
For details, see "Removing the Front Cover" on page 18 (E).
- 2 Reset the green centering.
For details, see "Resetting the Standard Data to the Factory Preset Levels" on page 89 (E).
- 3 Make sure that the center of the green hatch pattern aligns with the center of the screen.
If it does not align the center of the screen, there may be some problem with the installation.

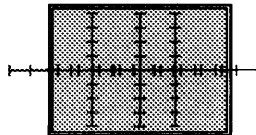

- 4 Make sure that the centers of the red and blue hatch patterns align at even intervals from the green hatch pattern.

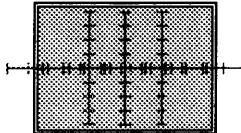

- 5 Loosen the red CRT fixing screws.
- 6 Insert the screwdriver into one of the adjustment holes, according to the screen size.

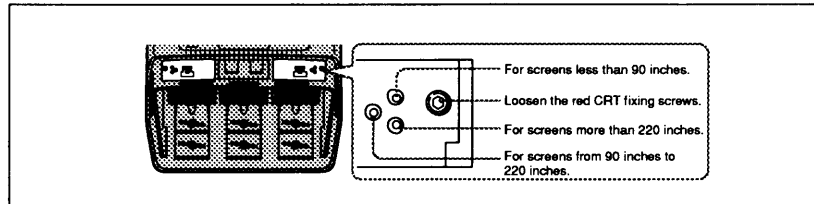

When using the screens larger than 220 inches, adjust the centering by ZONE adjustment after adjusting with the adjustment hole for more than 220 inches.

- 7 Turn the screwdriver until the vertical line of the red cross-hatch pattern converges with the green pattern.
- 8 Tighten the CRT fixing screws.
- 9 Repeat steps 6 to 9 for the blue CRT.

Modifying Parts

Changing the Polarity

By default, this projector is preset for use in front projection when installed on the floor/desk. When the projector is installed on the ceiling or used in rear projection, you have to change the polarity of CRT corresponding to the installation methods.

For details, see the table on next page.

Change the polarity to obtain the correct picture.

A The letters are backward.

Change the connectors on the ED board.

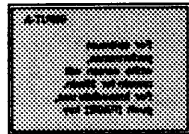

B The letters are upside down.

Change the switch position on the L board.

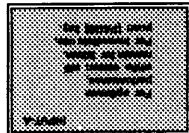

C The letters are upside down and backward.

Change the switch position on the L board and the connectors on the ED board.

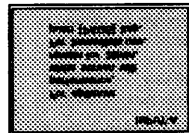

Change polarity according to the installation method, described below.

Installation methods	Change on L board	Change on ED board	On-screen display (See page 22 (E))
Front projection, ceiling	Y	Y	C
Rear projection, floor	N	Y	A
Rear projection, ceiling	Y	N	B
Rear projection using mirrors			
① Using a mirror	N	N	Correct picture
② Using a mirror	Y	Y	C
③ Using two mirrors	N	Y	A
Others	Display letters on the screen so that you can determine which changes to make.		

Y: Necessary
N: Not necessary

Modifying Parts

How to change the polarity

- 1 Turn off the power.
- 2 Remove the front cover.
For details, see "Removing the Front Cover" on page 18 (E).
- 3 Change switches or connectors.
L board: Set to the desired position.
NOR: Normal picture
INV: Invert the picture vertically.
ED board: Reinsert the connectors after turning them over (180°).

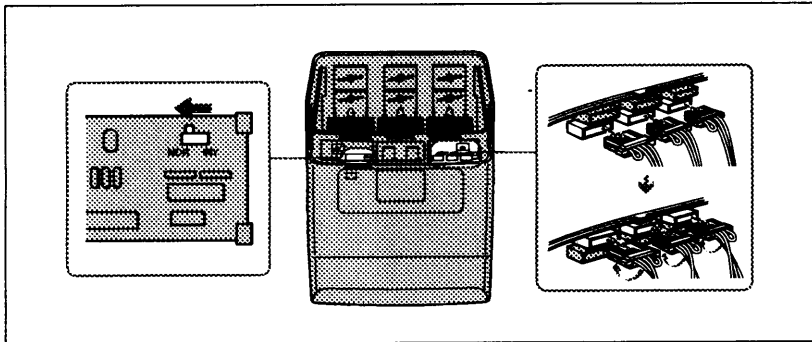

- 4 Make sure to insert the connectors firmly, then restore the front cover.

Note

After changing the polarity, the center of the picture may be off from the center of the screen. In this case, adjust the registration and centering for the screen.

Setting the Dynamic Picture

When using a composite or Y/C input video signal, you can get high quality picture contrast by switching the DYNAMIC PIC SW on the BA board. (This switch is set to OFF at the factory).

- 1 Remove the front cover.
For details, see "Removing the Front Cover" on page 18 (E).
- 2 Remove the hood.
 - ① Loosen the fixing screws.
 - ② Pull up the hood and slide it backward.

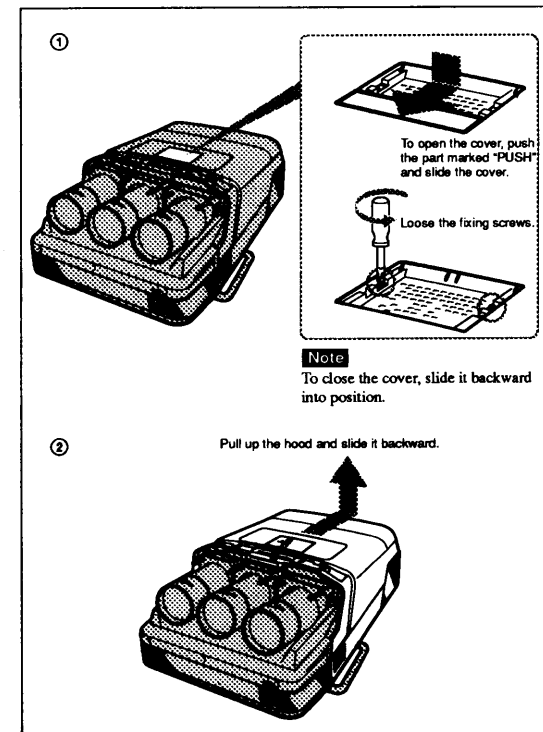

(Continued)

Modifying of Parts

- 3** Loosen the three screws on the upper part of the connector panel, and then remove the frame.

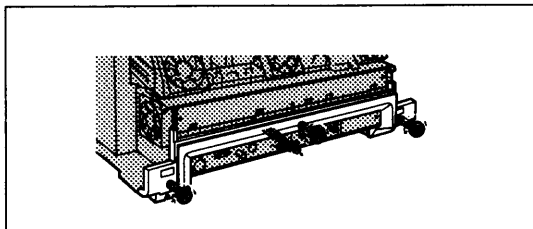

- 4** Remove the two screws on the upper cover of the connector panel, and remove the cover.

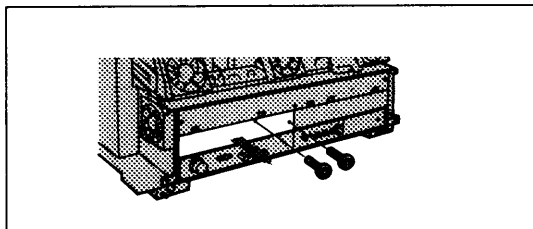

- 5** Pull the BA board out toward you and set the SW 1: DYNAMIC PIC SW on the board to ON.

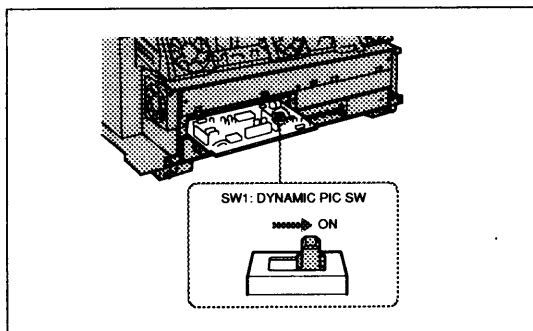

- 6** Replace the parts following steps 1 to 4 in reverse.

VPH-1292Q/QM MODEL ONLY

Location and Function of Connectors

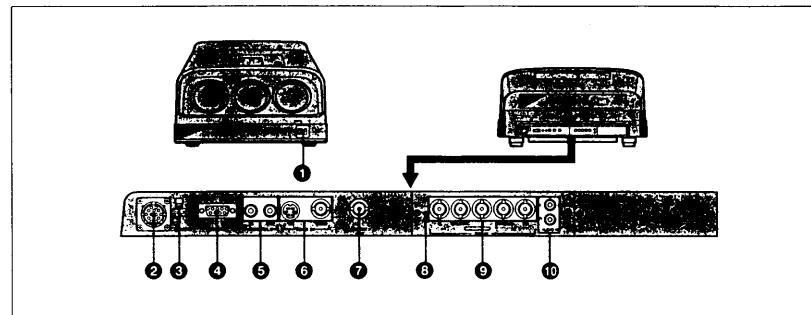

1 AC IN socket

Connect the supplied AC power cord here. This socket accepts 120V AC power (for the VPH-1292Q) or 220 to 240V AC (for the VPH-1292QM).

2 REMOTE 1 connector (14-pin, male)

Connects to the REMOTE 1 connector of the optional PC-1271/1271M Signal Interface Switcher.

3 5 BNC switch

Normally, set to the NORMAL. If you wish to project a high resolution picture using the PC-1271/1271M Signal Interface Switcher, set to the 5BNC position.

For details, see "When Projecting the High Resolution Pictures" on page 34 (E).

4 REMOTE 2 connector (9-pin, female)

Connects to the RS-422 interface for communication with a computer.

5 CONTROL S IN/OUT jacks (phono type)

Connects to the CONTROL S connector of other Sony equipment. You can control the whole system with a single remote control.

CONTROL S IN: Connects to CONTROL S OUT jack of the supplied remote control to be used as a wired remote control.

Note

When using this connector, the remote control detector on the projector does not function.

6 VIDEO IN connectors

Y/C (4-pin, mini-DIN type): Connects to the Y/C video output (S VIDEO OUT) of a VCR.

VIDEO (BNC type): Connects to the composite video output of the video equipment.

Note

The VIDEO connector is disconnected automatically when a cable is connected to the Y/C connector.

7 VIDEO OUT connector (BNC type)

Connects to the video input of a color monitor. This output signal is the loop-through output from the input signal to the VIDEO IN connectors.

8 Indicator

Lights when INPUT A mode is selected.

9 RGB IN connectors (BNC type)

R, G/G SYNC, B, SYNC/HD, VD connectors: Connects to the RGB outputs of a computer or a video camera.

10 AUDIO IN L/R jacks (phono type)

Not used.

Location and Function of Connectors

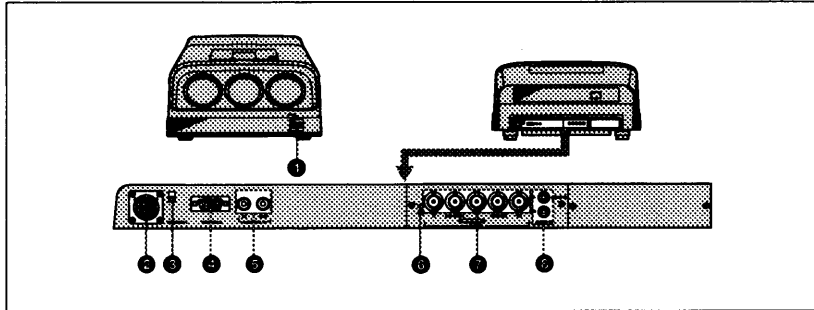

1 AC IN socket

Connect the supplied AC power cord here. This socket accepts 220 to 240V AC.

2 REMOTE 1 connector (14-pin, male)

Connects to the REMOTE 1 connector of the optional PC-1271M Signal Interface Switcher.

3 5 BNC switch

Normally, set to the NORMAL.

If you wish to project a high resolution picture using the PC-1271M Signal Interface Switcher, set to the 5BNC position.

For details, see "When Projecting the High Resolution Pictures" on page 34 (E).

4 REMOTE 2 connector (9-pin, female)

Connects to the RS-422 interface for communication with a computer.

5 CONTROL S IN/OUT jacks (phono type)

Connects to the CONTROL S connector of other Sony equipment. You can control the whole system with a single remote control.

CONTROL S IN: Connects to CONTROL S OUT jack of the supplied remote control to be used as a wired remote control.

Note

When using this connector, the remote control detector on the projector does not function.

6 Indicator

Lights when INPUT A mode is selected.

7 RGB IN connectors (BNC type)

R, G/G SYNC, B, SYNC/HD, VD connectors:
Connect to the RGB outputs of a computer or a video camera.

8 AUDIO IN L/R jacks (phono type)

Not used.

Connecting Directly to the Projector

You can expand the system connections by installing the optional interface board on INPUT A or B section, or in combination shown in the examples below.

When a color monitor is not connected to the computer

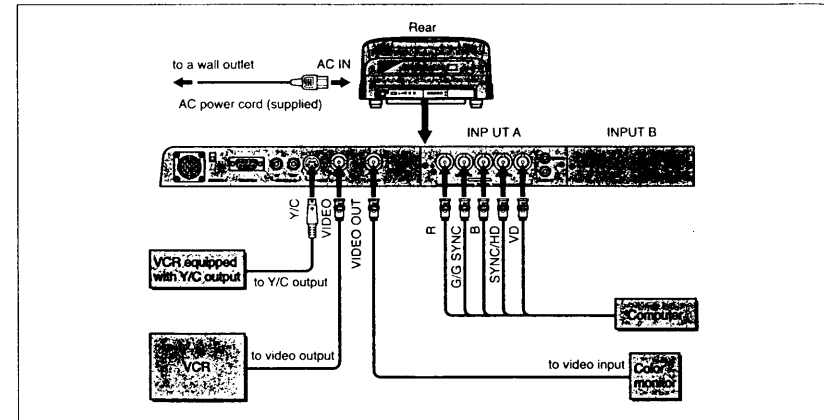

Notes

- The VIDEO connector is disconnected automatically when a cable is connected to the Y/C connector.
- The external sync signal has priority over the internal sync signal. However, when the external sync signal is not stable, the internal sync signal has priority.

Connecting Directly to the Projector

You can expand the system connections by installing the optional interface board on INPUT A or B section, or in combination shown in the examples below.

When a color monitor is not connected to the computer

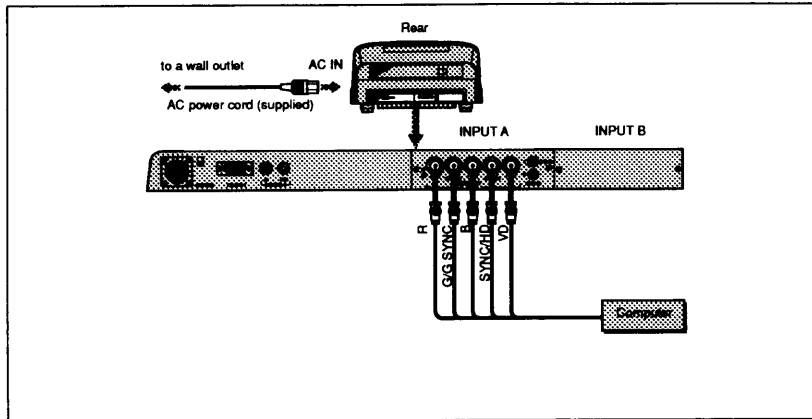

Note

The external sync signal has priority over the internal sync signal. However, when the external sync signal is not stable, the internal sync signal has priority.

When a color monitor is connected to the computer

Use the IFU-1271/1271M Signal Interface Unit.

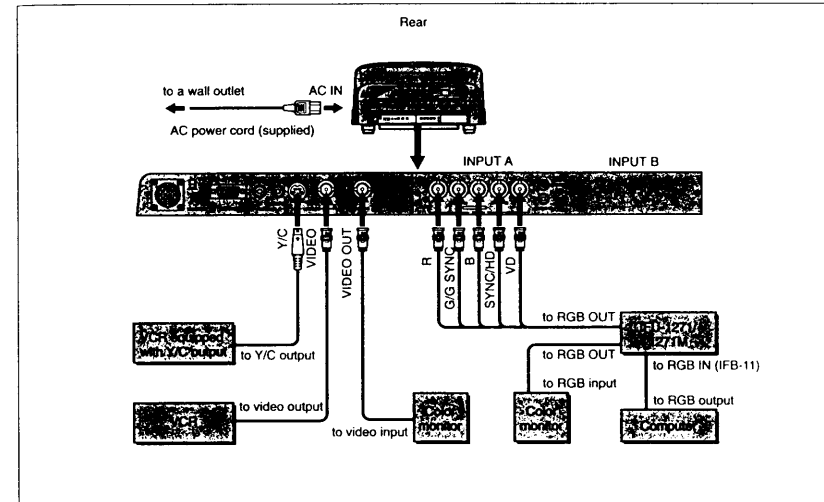

When a color monitor is connected to the computer

Use the IFU-1271M Signal Interface Unit.

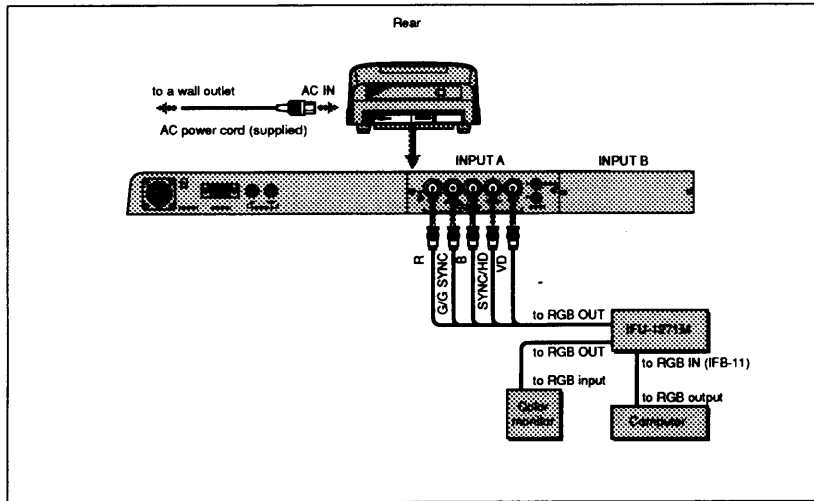

Connecting Directly to the Projector

When a computer is connected to the projector using the SIC-series connecting cable

Install the optional interface board to the INPUT A or INPUT B section.

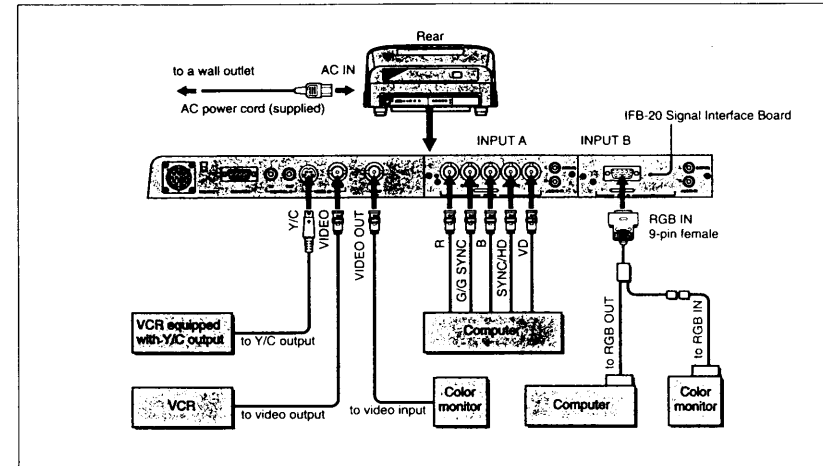

Note

Use the standard SIC cable. Be sure not to extend the length of the cable. Otherwise, the picture may be distorted.

Installing the optional interface board

- 1 Loosen the two screws on the INPUT A or INPUT B panel and pull out the board toward you. (The screws are retained in the hole, to prevent them from getting lost.)
- 2 Insert the optional interface board and tighten the screws.

Connecting Directly to the Projector

When a computer is connected to the projector using the SIC-series connecting cable

Install the optional interface board to the INPUT A or INPUT B section.

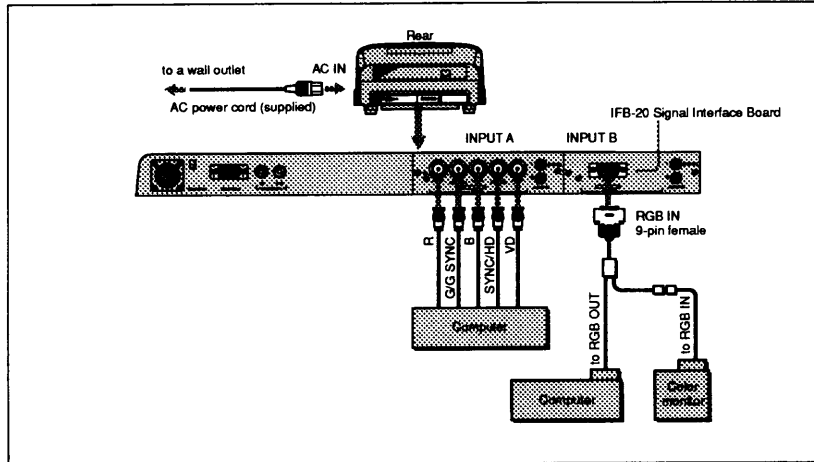

Note

Use the standard SIC cable. Be sure not to extend the length of the cable. Otherwise, the picture may be distorted.

Installing the optional interface board

- 1 Loosen the two screws on the INPUT A or INPUT B panel and pull out the board toward you. (The screws are retained in the hole, to prevent them from getting lost.)
- 2 Insert the optional interface board and tighten the screws.

Connecting When the Projector Is Away From Other Equipment

Use the IFU-1271/1271M Signal Interface Unit or the PC-1271/1271M Signal Interface Switcher (not supplied).

Connecting a computer using the BNC cable

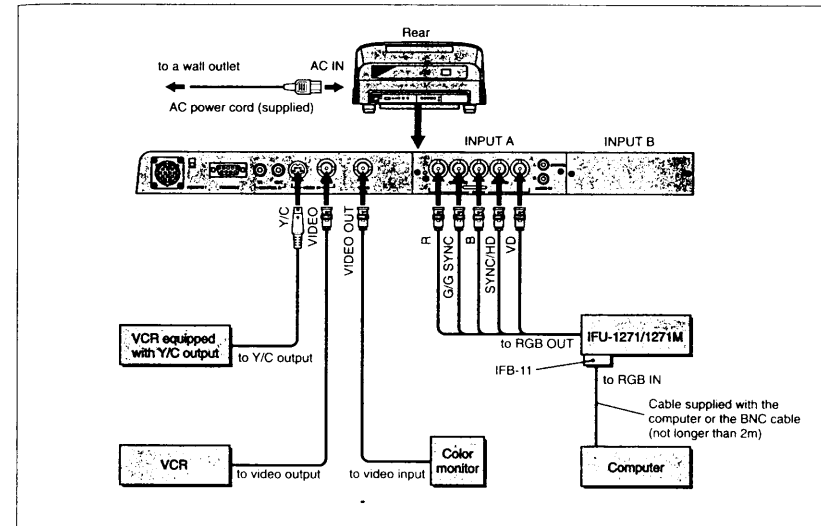

Note

When using a color monitor, connect the RGB input on the monitor to the RGB OUT connectors on the IFU-1271/1271M Signal Interface Unit.

Connecting When the Projector is Away From Other Equipment

Use the IFU-1271M Signal Interface Unit or the PC-1271M Signal Interface Switcher (not supplied).

Connecting a computer using the BNC cable

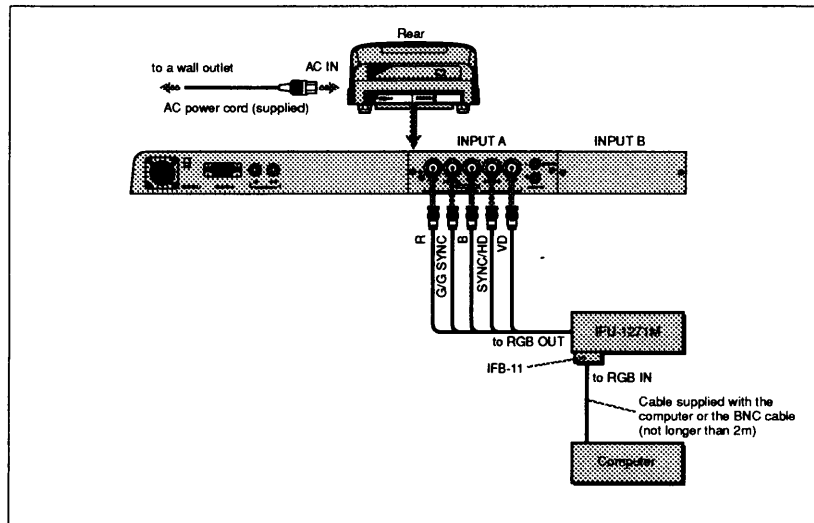

Note
When using a color monitor, connect the RGB input on the monitor to the RGB OUT connectors on the IFU-1271M Signal Interface Unit.

Connecting When the Projector Is Away From Other Equipment

Connecting the computer using the SIC-series connecting cable

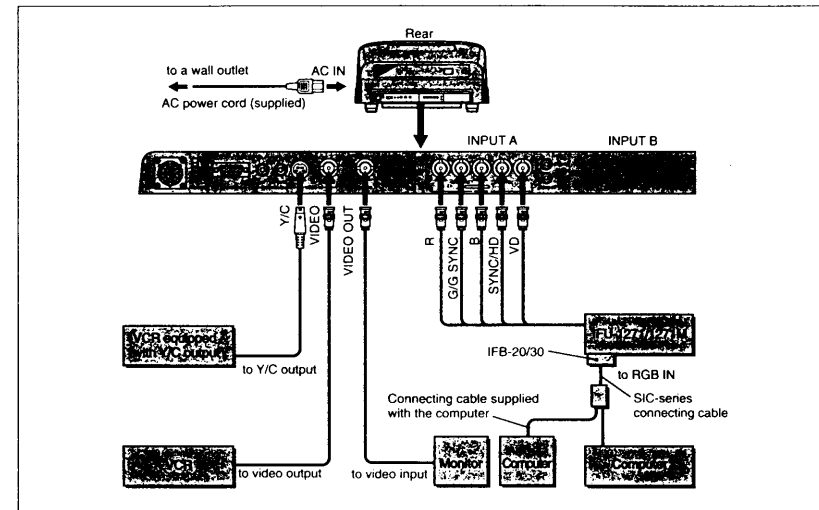

Note
To prevent the signal loss, be careful with the length and thickness of the cable when projecting the high resolution picture.

Connecting When the Projector Is Away From Other Equipment

Connecting the computer using the SIC-series connecting cable

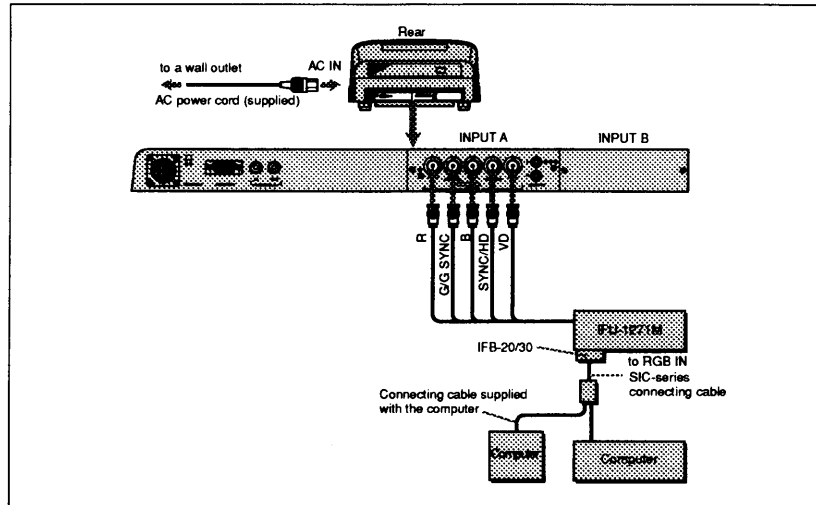

Note

To prevent the signal loss, be careful with the length and thickness of the cable when projecting the high resolution picture.

Connecting More Than Four Input Sources

Using the PC-1271M Signal Interface Switcher

When you use the PC-1271M Signal Interface Switcher (not supplied), you can connect easily more than four input sources. Connect the projector to the PC-1271M using the CCQ-BRS or SIC-M connecting cable. You can select up to 16 inputs by pressing the SWITCHER/INDEX keys on the remote control or the SWITCHER keys on the control panel of the projector.

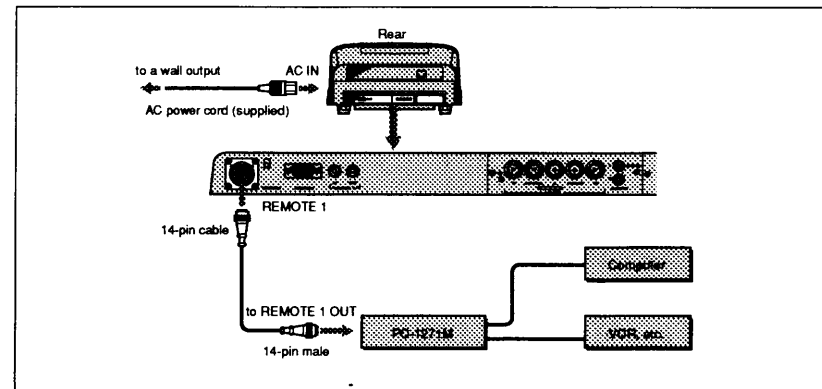

Choose the appropriate cable from the following table.

1 m	2 m	5 m	10 m	15 m	25 m	50 m
-	CCQ-2BRS	CCQ-5BRS	CCQ-10BRS	-	CCQ-25BRS	CCQ-50BRS
SIC-M-1	-	SIC-M-5	-	SIC-M-15	SIC-M-25	SIC-M-50

Notes

- Insert the female and male plugs of the CCQ-BRS or SIC-M cable correctly.
- You can extend the CCQ-BRS or SIC-M cable up to 50 m.
- You can connect other equipment to the VIDEO IN and RGB IN connectors even when the switcher is connected.

Using the SWITCHER/INDEX (SWITCHER) keys

When using the remote control, set the SWITCHER/INDEX select switch to SWITCHER. Press a number key between 1 and 8 to select the input number of the switcher. When two switchers are connected, use the SECOND key. To control the second switcher (SINGLE/SECOND/OTHER switch on the switcher is set to SECOND), first press SECOND key and then a number key.

Connecting More Than Four Input Sources

When Projecting the High Resolution Pictures

When projecting the video signal which is above 70 MHz or projecting the high resolution pictures such as the computer graphics (CG), you should set the projector to the high resolution mode by switching the 5BNC switch.

To set the projector to the high resolution mode, set the 5BNC switch on the rear panel of the projector to 5BNC.

Note

Before this setting, turn off the power.

- 1 Set the 5BNC switch on the rear panel to 5BNC.

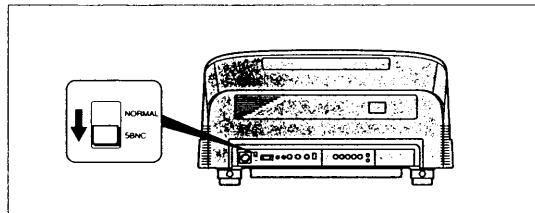

- 2 Connect the REMOTE 1 connectors of the projector and switcher with the CCQ-BRS or SIC-M cable.
- 3 Connect the RGB IN connectors of the projector and the MONITOR OUT connectors of the switcher with five BNC cables.

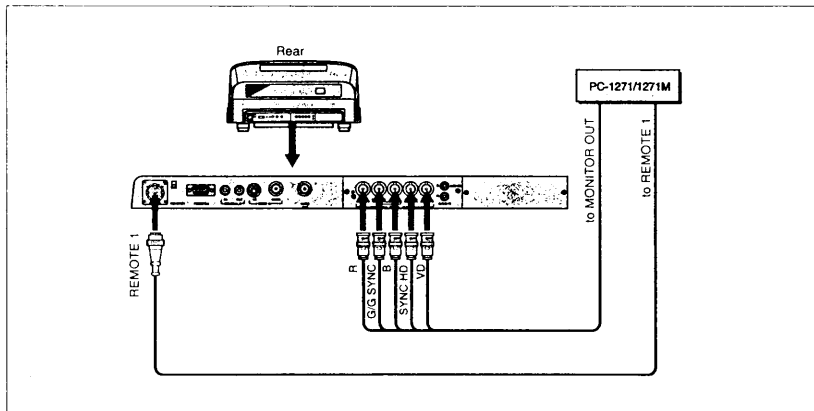

34 (E) Connections

Connecting More Than Four Input Sources

When Projecting the High Resolution Pictures

When projecting the video signal which is above 70 MHz or projecting the high resolution pictures such as the computer graphics (CG), you should set the projector to the high resolution mode by switching the 5BNC switch.

To set the projector to the high resolution mode, set the 5BNC switch on the rear panel of the projector to 5BNC.

Note

Before this setting, turn off the power.

- 1 Set the 5BNC switch on the rear panel to 5BNC.

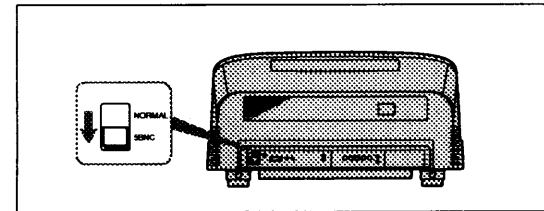

- 2 Connect the REMOTE 1 connectors of the projector and switcher with the CCQ-BRS or SIC-M cable.
- 3 Connect the RGB IN connectors of the projector and the MONITOR OUT connectors of the switcher with five BNC cables.

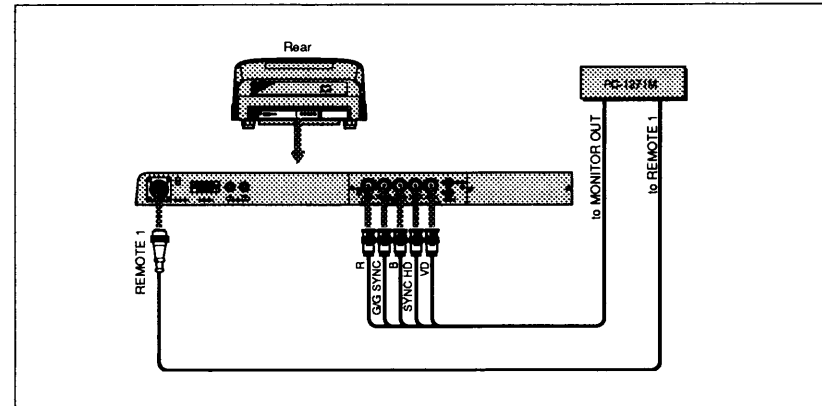

34 (E) Connections

Adjustment Procedures

Before Starting Adjustment

Before adjusting the registration, make sure to turn on the projector and allow it to warm up for 20 minutes.

The projector is designed with a warm-up period of about 20 minutes after turning on the power. During this period, it displays a white screen with the message shown below. 35 seconds after the warming up starts, the message will disappear temporarily and will appear subsequently for 5 seconds every 30 seconds.

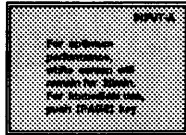

Press the PAGE key to cancel the warming up, if you wish to see the picture immediately.

You may also set the projector for a shorter or no warming up period. For details, see "Changing the Initialization Period" on page 93 (E).

Perform each adjustment with the supplied remote control before connecting to the external equipment. After the adjustment, save the data. Next, adjust for each input signal precisely.

Follow the procedure below.

- ① Prepare the remote control. (page 36 (E))
- ↓
- ② Adjust roughly without input signal. (page 49 (E))
- ↓
- ③ Save the adjustment data as the standard data. (page 77 (E))
- ↓
- ④ Adjust fine for each input signal. (page 80 (E))
- ↓
- ⑤ Activate the memory protection of the remote control. (page 91 (E))
- ↓
- ⑥ Adjust the picture. (page 92 (E))

For Remote Control

All adjustments, except focusing the lens, can be made with the supplied remote control.

Normally, the adjustment keys on the remote control are inoperable to prevent accidental adjustments. Cancel the protection before adjusting.

Since the remote control uses infrared, you can use it without a wire.

However, in order to correctly control the projector, you should connect the remote control to the projector with the supplied remote control cable.

Preparation

- 1 Insert three of the supplied AA size batteries (R6) with the polarities lined up correctly.
- 2 Connect the remote control to the projector.
- 3 Turn on the MAIN POWER switch on the projector, and then press the POWER ON key on the remote control.
- 4 Remove the panel cover of the adjustment keys.

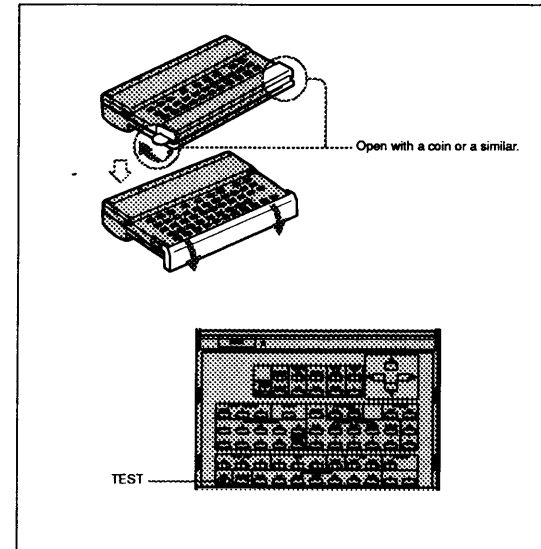

5 Hold down the TEST key for 5 seconds.

The following display appears.

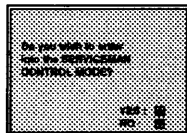

6 Press the ▲ key.

The protection on the adjustment keys is removed and the keys are enabled.

After the adjustment, reactivate the protection.

For details, see "Protecting the Setting" on page 91 (E).

Notes for wireless remote control operation

- Be sure that there are no obstructions between the remote control and the projector.
- Operating range is limited. The shorter the distance between the remote control and the projector, the wider the angle in which the remote control can control the projector.

Battery Installation

1 Push to open the lid.

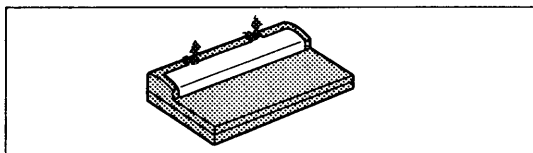

2 Install three AA (R6) batteries with the correct polarity.

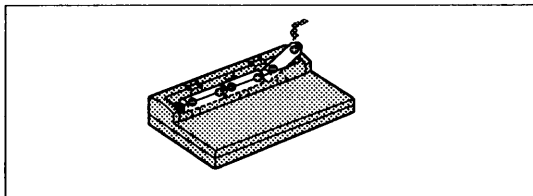

(Continued)

For Remote Control

3 Replace the lid.

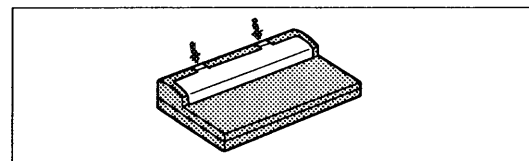

Notes on batteries

- If the projector does not operate properly, the batteries might be worn out. Replace all three of them with new ones.
- The life of the batteries depends on frequency of usage and how often you use the LIGHT button. If they are worn out quickly, replace them with new alkaline batteries.
- To avoid damage from possible battery leakage, remove the batteries when the remote control will not be used for a long time.

Connecting the remote control to the projector

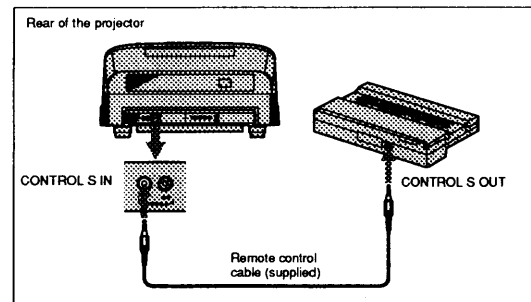

Note

When you connect the remote control to the projector as mentioned above, the remote control detector of the projector does not function. For wireless operation, be sure to disconnect both plugs from the projector and the remote control.

Keys on the Remote Control

Note

The C.B, SECAM, INPUT SELECT VIDEO, AUDIO MUTE and VOLUME keys do not function with this projector.

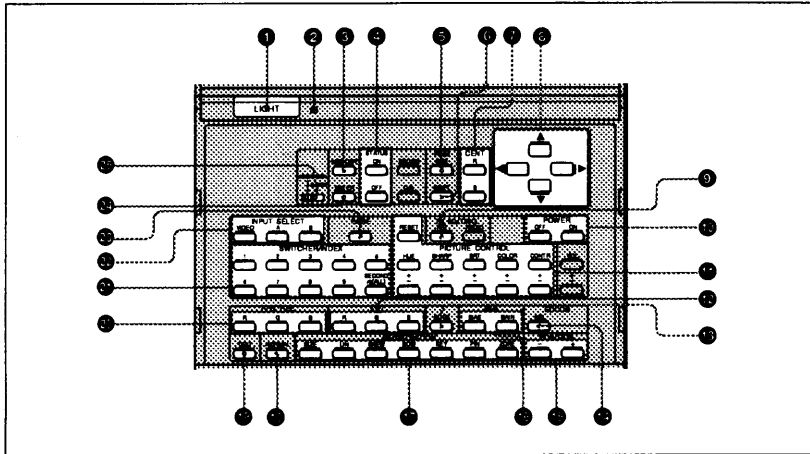

1 LIGHT button

Illuminates the key indicators on the remote control. If you do not use the keys for approximately 30 seconds, the light automatically goes out.

2 Transmission indicator

Lights each time you press a key.

3 MEMORY key

Stores various adjustment data into memory.

4 STATUS ON/OFF key

ON: Restores the on-screen display.
OFF: Removes the on-screen display.

Note

The PAGE display appears even when you press the OFF key.

5 RGB SIZE key

Adjusts the size of the picture for the video and RGB signal inputs.

To adjust the size, press this key. You can adjust the size of the picture with the four arrow keys. After adjustment, save the data by pressing the MEMORY key.

- ◀: Reduces the horizontal size.
- ▶: Expands the horizontal size.
- ▲: Expands the vertical size.
- ▼: Reduces the vertical size.

For Remote Control

6 RGB SHIFT key

Adjusts the shift of the picture for the RGB signal input.

To adjust the shift, press this key. You can adjust the shift of the picture with the four arrow keys. The picture shifts according to the direction of the arrow. After adjustment, save the data by pressing the MEMORY key.

Note

This key does not function with the composite or Y/C video signal input.

7 CENT R/B keys

Adjust the centering of the red and blue.

You can adjust the centering with the four arrow keys. **CENT R:** Enters the red centering adjustment mode. **CENT B:** Enters the blue centering adjustment mode.

8 Arrow keys

Used for various adjustment functions.

9 PJ MUTING PIC key

Cuts off the picture. To restore the picture, press the key again or the CONTR + key.

10 POWER ON/OFF keys

Turn the projector on and off.

11 PICTURE CONTROL keys

Adjust picture condition: hue, sharpness, brightness, color, and contrast. To restore the standard levels, press the RESET key.

12 ADJ R/G/B (adjust red/green/blue) keys

Select color to be adjusted when adjusting the registration.

13 BLKG (blanking) key

Enters the blanking adjustment mode.

You can adjust the blanking with the four arrow keys. For details, see "Adjusting the Blanking" on page 76 (E).

14 FOCUS MG key

Enters each of the magnetic focus, AQP and DQP adjustment mode.

For details, see "Adjusting the Focus" on page 48 (E).

15 POSITION +/- keys

Used for adjusting zone and blanking.

For details, see "Releasing the Blanking" on page 59 (E) and "Adjusting the Blanking" on page 76 (E).

16 W/B (white balance) keys

Enter the white balance adjustment mode.

BIAS: Adjusts cut off.

GAIN: Adjusts drive.

**17 REGISTRATION keys
SIZE/LIN/SKEW/BOW/KEY/PIN/ZONE**

Select the desired item for adjusting registration. You cannot adjust the registration with the four arrow keys, ADJ keys and POSITION +/- keys.

For details, see "Adjusting the Registration" on page 56 (E).

18 NORMAL key

Cancel the test pattern or serviceman control mode.

19 TEST key

Displays the internal test patterns.

Each time you press this key, 8 test patterns appear sequentially on the screen. When adjusting registration and white balance, appropriate patterns will appear for each adjustment.

For details, see "Test Patterns" on page 46 (E).

20 CUT OFF keys

Select the color to be turned off when adjusting the registration. Press again to turn on the color.

R: Red signal

G: Green signal

B: Blue signal

21 SWITCHER/INDEX keys

When the SWITCHER/INDEX select switch is set to SWITCHER

Designate the input from switcher when the PC-1271M Signal Interface Switcher is connected. The SECOND key is used when two switchers are connected.

To select the input from the second switcher (when the SINGLE/SECOND/OTHER switch on the switcher is set to SECOND), press a number key between 1 and 8 after pressing the SECOND key.

When the SWITCHER/INDEX select switch is set to INDEX

These keys function when the optional IFB-101 Interface Board is installed and multiple projectors are connected.

For details, refer to the Operating Instructions of the IFB-101.

INPUT SELECT keys

Select the input signal.

A: The signal input from the RGB IN connectors

B: The signal input from the connectors of B section (when the optional interface unit is installed)

PAGE key

Displays and switches between the following five on-screen displays. (You can adjust parameters only on PAGE 1, 2, 3, and 5.)

PAGE 1: Displays the status of STATUS ON/OFF and PIC MUTING ON/OFF.

PAGE 2: Displays the picture conditions parameters; contrast, color, brightness, sharpness and hue.

PAGE 3: Displays the color temperature, clamp setting and vertical shift range.

PAGE 4: Displays the input signal conditions; fH, fV, H/C-sync, V-sync, Sync on Green, input signal, and registration memory block assignment.

PAGE 5: Display the current use time of each cathode-ray tube (CRT) and the baud rate setting for communicating via the RS-422.

For details of these pages, see "PAGE Displays" on next page.

ENTER key

Functions when the optional IFB-101 Interface Board is attached and multiple projectors are connected.

For details, refer to the Operating Instructions of the IFB-101.

SWITCHER/INDEX select switch

Selects the SWITCHER/INDEX key function.

When using the switcher as the input selector, set to SWITCHER. When using the IFB-101 Interface Board and multiple projectors, set to INDEX.

PAGE Displays and Test Patterns

PAGE Displays

Press the PAGE key to display the following five on-screen displays. You can adjust the parameters on PAGE 1, 2, 3 or 5.

The display changes in the following order every time you press the PAGE key:

PAGE 1 → PAGE 2 → PAGE 3 → PAGE 4 → PAGE 5

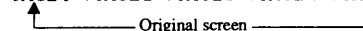

PAGE 1

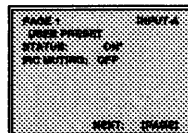

STATUS: ON/OFF

The setting is stored even when the power is turned off. If the on-screen display does not appear, check that STATUS ON is displayed.

PIC MUTING: ON/OFF

Whenever the power is turned on, PIC MUTING is set to OFF. If the picture does not appear, check that PIC MUTING is set to ON.

"..." indicates that the control does not function with the current input signal.

To change the settings, adjust with the appropriate keys.

PAGE 2

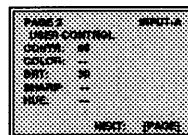

Picture settings; contrast, color, brightness, sharpness and hue are displayed.

The levels can be changed independently for the signal input from different input connectors. (You can check from the message displayed in the upper right corner of the screen).

"..." indicates that the control does not function with the current input signal. (In this case, the input signal is RGB.)

To change the levels, use the PICTURE CONTROL key.

PAGE 3

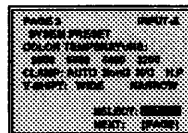

The color temperature, clamp and V-shift adjustment mode settings are displayed.

The selected item blinks in green.

To change the setting, adjust by pressing the ◀, ▶, ▲ and ▼ keys.

COLOR TEMPERATURE: 9300/6500/5400/3200

Select the appropriate color temperature according to your application and the picture source.

The color temperature of the projector is preset to 6500 at the factory.

V-SHIFT: WIDE/NARROW

The V-shift of the projector is preset to **WIDE** at the factory. When some particular RGB signals are input to projector, the picture may be distorted vertically. In this case, set to **NARROW**. Adjustable range in the lower direction will become narrow.

If the horizontal frequency of the signal is too high, the V-SHIFT is automatically set to **NARROW**.

For details of the clamp setting, see "Correcting the Luminance of the Picture - Clamp Setting" on page 87 (E).

Notes

- "CLAMP" and "V-SHIFT" are not displayed when the input mode is VIDEO.
- If the horizontal frequency of the input signal (fH) is more than 100 kHz, V-SHIFT is automatically set to **NARROW** and its setting is not displayed.

PAGE 4

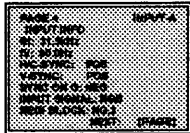

The signal input conditions are displayed.
fH: Horizontal frequency of the input signal
fV: Vertical frequency of the input signal

You can select "POS (positive)" or "NEG (negative)" for following settings:

H/C-SYNC: Polarity of the H/C-SYNC

V-SYNC: Polarity of the V-SYNC

SYNC ON G: Polarity of the SYNC on the Green

- When POS (NEG) is displayed in green:
The picture is being projected using its sync signal.
- When POS (NEG) is displayed in white:
The picture is being projected without using its sync signal.

INPUT SIGNAL: Current input signal

Y/C: S video input signal from the optional IFB-1000 (when installing the optional IFB-1000 to the projector)

RGB: RGB input signal

NTSC: NTSC input signal from the optional IFB-1000 (when installing the optional IFB-1000 to the projector)

PAL: PAL input signal from the optional IFB-1000 (when installing the optional IFB-1000 to the projector)

SECAM: SECAM input signal from the optional IFB-1000 (when installing the optional IFB-1000 to the projector)

B & W: Black and white input signal from the optional IFB-1000 (when installing the optional IFB-1000 to the projector)

Internal oscillation: Internal oscillation mode (No signal is input.)

IDTV: Input signal from the optional IFB-3000 (when installing the optional IFB-3000 to the projector)

HDTV: Input signal from the optional IFB-1300 (when installing the IFB-1300 to the projector)

COMPONENT: Input signal from the optional IFB-1200 (when installing the IFB-1200 to the projector)

REGI BLOCK: The registration memory block number to which the input signal is assigned.

For details, see the table on page 78 (E).

PAGE Displays and Test Patterns

PAGE 5

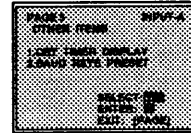

You can select the current usage time display and the baud rate¹⁾ setting display.

The selected item blinks in green.

To display either page, select the item with the ▲ and ▼ keys, and then press the ► key.

When the "1. CRT TIMER DISPLAY" is selected

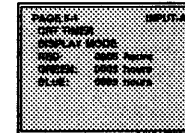

The use time of each cathode-ray tube is displayed in one-hour intervals.

RED: Use time of red CRT

GREEN: Use time of green CRT

BLUE: Use time of blue CRT

When the "2. BAUD RATE PRESET" is selected

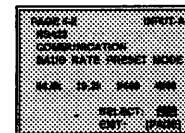

The baud rate setting for communication through the RS-422 cable is displayed.

The selected item blinks in green. To change the setting, press the ◀ and ▶ keys.

1) The baud rate setting designates the data communication speed via RS-422 between the projector and computer. Set the appropriate baud rate to match speed of the connected computer.

Screen messages

Color codes

Four colors are used in the letters of on-screen display.

Color	Meaning
Green	Function and condition, item being selected on PAGE display
Cyan	Operation guide and messages
Yellow	Caution and error messages
White	Item being adjusted, item not being selected on PAGE display

Error message

When an error occurs, the following messages will appear.

Message	Meaning
Not applicable!	The key does not function in the current mode.
PIC MUTING	Picture muting mode is on. If you wish to adjust the picture controls, press the PJ MUTING PIC key to cancel the PIC MUTING mode.
Overflow!	The setting is outside the adjustable range limits.
NO INPUT	No signal has been received.
OFF	On-screen display STATUS is set to OFF. To restore the on-screen display, press the STATUS ON key.
Overcorrection	When adjusting registrations, some settings are overcorrected. Reset them to the factory preset data. Then, check that the projector is correctly installed.

PAGE Displays and Test Patterns

Test Patterns

In each adjustment mode, an appropriate test pattern appears. In addition, you can display other test patterns by pressing the TEST key.

List of test patterns

Cross hair

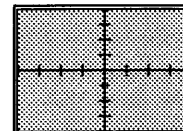

Hatch (9 × 9)

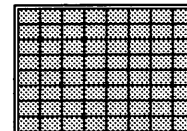

Hatch (reverse)

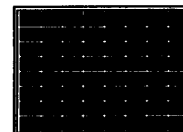

Dot



H

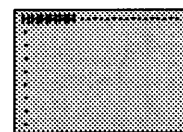

H (reverse) (for adjusting the magnet focus only)

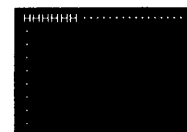

White

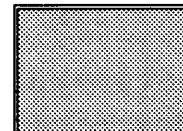

Window

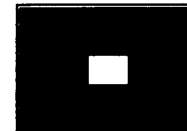

PLUGE¹⁾

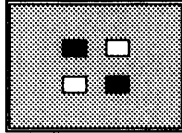

Note

The outside bold line stands for the edge of the screen.

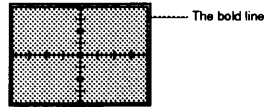

Test pattern in each mode

Mode	By pressing the TEST key, the patterns cycle through the following order.	
Normal	Cross hair → Hatch (9 × 9) → Hatch reverse → Dot → H → White → Window → PLUGE → Cross hair → ...	
Registration	Cross hair ↔ Hatch (9 × 9)	Select the desired one.
SIZE		
LIN		
SKEW		
BOW		
KEY	Hatch (5 × 5) ↔ Hatch (9 × 9)	Select the desired one.
PIN		
ZONE	Hatch (9 × 9) + Cursor	
White balance		
BIAS	PLUGE	
GAIN	Window ↔ White	
BLKG	Hatch (9 × 9)	
CENT RGB	Cross hair ↔ Hatch (5 × 5)	Select the desired one.
MG (magnetic)	H → H (reverse) → Hatch (9 × 9) → Hatch (reverse)	
FOCUS	→ Dot → H → ...	

1) PLUGE is an abbreviation for Picture Line Up Generating Equipment.

Adjusting the Focus

Procedure

Follow the procedure below.

- ① Remove the front cover. (page 18 (E))
 - ↓
 - ② Set the remote control to the serviceman adjustment mode. (page 36 (E))
 - ↓
 - ③ Select the NO INPUT mode. (page 49 (E))
 - ↓
 - ④ Display the H-pattern. (page 49 (E))
 - ↓
 - ⑤ Reset both CONTR (contrast) and BRT (brightness) levels. (page 49 (E))
 - ↓
 - ⑥ Adjust the green lens focus. (page 49 (E))
 - ↓
 - ⑦ Adjust the green magnetic focus, AQP (Axis Quadrupole) and DQP (Diagonal Quadrupole). (pages 51 (E) to 54 (E))
Repeat steps ④ and ⑦ until the green CRT focuses.
 - ↓
 - ⑧ Adjust the red lens focus. (page 55 (E))
 - ↓
 - ⑨ Adjust the red magnetic focus, AQP (Axis Quadrupole) and DQP (Diagonal quadrupole). (page 55 (E))
Repeat steps ④ and ⑨ until you finish the red focus adjustment.
 - ↓
 - ⑩ Adjust the blue lens focus. (page 55 (E))
 - ↓
 - ⑪ Adjust the blue magnetic focus, AQP (Axis Quadrupole) and DQP (Diagonal quadrupole). (page 55)
 - Repeat steps ④ and ⑪ until you finish the blue focus adjustment.
 - ↓
- Proceed to the registration adjustment.**

Adjusting the Green Focus

Adjusting the green lens focus

- 1 Remove the front cover.
- 2 Set the remote control to the serviceman adjustment mode.
For details, see "Preparation" on page 36 (E).
- 3 Press the INPUT SELECT A or B key until "NO INPUT" appears.
Or, set the SWITCHER/INDEX select switch to SWITCHER, and then press a number key from 1 to 8 corresponding to a line that is not connected to a signal.

"NO INPUT" appears on the screen.

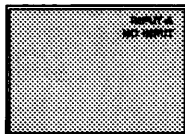

- 4 Press the TEST key on the control until the H-pattern appears.

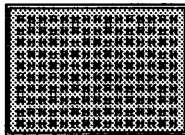

- 5 Press the RESET so that their adjustment levels are reset. (The CONTR level is 80, and the BRT level is 50.)
- 6 Press the CUT OFF R and B keys to display the green signal only.
- 7 Loosen the G1 screw, slide it so that the letters H at the center of the screen is in focus, and then tighten the screw.

(Continued)

Adjusting the Focus

- 8 Adjust the corner-focus.
Loosen the G2 screw, slide it so that the edge of the letter H at all four corners of the screen (Pay attention to the gray areas illustrated below.) are in focus, and then tighten the screw.
Repeat steps 7 and 8 until the green focus adjustment is completed.

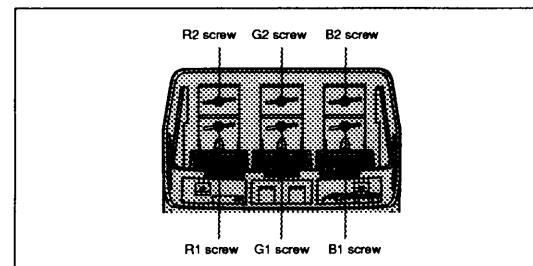
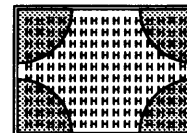

Hint for the lens focus adjustment

The letter "H" is made up of dots. Adjust the focus so that dots of the letter "H" can be clearly seen as illustrated below.



Proceed to the green magnetic focus adjustment.

Adjusting the green magnetic focus

After adjusting the lens focus, adjust the magnetic focus.

- 1 Press the FOCUS MG key.

The H-pattern appears on the screen, and the center of the screen lights for a moment.

- 2 Press the ◀ or ▶ key so that the letter H is in focus at the center of the screen.

- 3 Press the POSITION + key until "G-V" appears at the upper left of the screen.



Note

The on-screen display overlaps with the H-pattern.

- 4 Adjust the focus on the upper and lower sides. When the upper and lower sides of the screen are in focus, go to step 5.
 - ① Press the ◀ or ▶ key to set the focus value to MIN.

The H-pattern is de-focused in upper and lower sides of the screen.

- ② Press the POSITION + key until "V-PHASE" appears on the upper left of the screen.

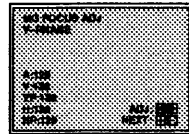

Notes

- The on-screen display overlaps with H-pattern.
- When adjusting, pay attention to the areas which blink immediately after you change the adjustment mode.

- ③ Press the ◀ or ▶ key to de-focus the upper and lower sides of the screen equally.
 - ④ Press the POSITION - key until "G-V" appears on the upper left of the screen.
 - ⑤ Press the ◀ or ▶ key so that the upper and lower sides of the screen are in focus. Repeat steps ② to ⑤ until the upper and lower sides of the screen are in focus precisely. *(Continued)*

Adjusting the Focus

- 5 Press the POSITION + key until "G-H" appears at the upper left of the screen.

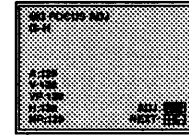

Note

The on-screen display overlaps with the H-pattern.

- 6 Adjust the focus on the right and left sides. When the right and left sides of the screen are in focus, go to "Adjusting the green AQP/DQP" on next page.

- ① Press the ◀ or ▶ key to set the focus value to MIN.

The H-pattern is out of focus at the right and left sides of the screen.

- ② Press the POSITION + key until "H-PHASE" appears at the upper left of the screen.

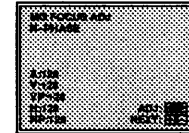

Notes

- The on-screen display overlaps with the H-pattern.
- When adjusting, pay attention to the areas which blink immediately after you change the adjustment mode.

- ③ Press the ◀ or ▶ key so that the right and left sides of the screen are equally out of focus.
 - ④ Press the POSITION - key until "G-H" appears at the upper left of the screen.

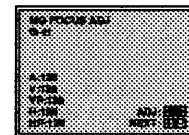

Note

- The on-screen display overlaps with the H-pattern.

- ⑤ Press the ◀ or ▶ key so that the right and left sides of the screen are in focus. Repeat steps ② to ⑤ until the right and left sides of the screen are precisely in focus.

Proceed to the green AQP/DQP adjustment.

Adjusting the green AQP/DQP

After adjusting the magnetic focus, adjust the AQP (Axis Quadrupole) and DQP (Diagonal Quadrupole).

What is the AQP/DQP adjustment?

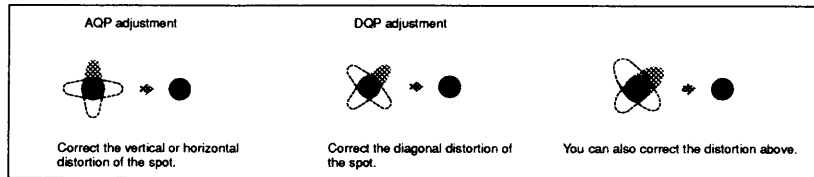

Adjust the AQP and DQP with the following procedure.

- 1 Press the INPUT SELECT A or B key on the remote control so that "NO INPUT" appears.
- 2 Press the FOCUS MG key.
- 3 Press the POSITION + key until "ADJ AQP/DQP" appears at the upper left of the screen.

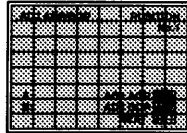

(Continued)

Adjusting the Focus

- 4 Correct the focus for the each part of the screen.
 - ① Press the ◀ or ▶ key to optimize the AQP.
 - ② Press the ▲ or ▼ key to optimize the DQP.
 - ③ Press the POSITION + key so that the part to be corrected cycles to the next part of the screen in the order illustrated below. When you press the POSITION – key, the part to be corrected cycles through the reverse order. Repeat steps ① to ③ until you correct all the AQP and DQP for every part of the screen.

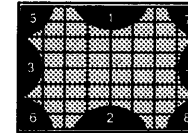

Proceed to adjust the red lens focus.

Adjusting the Red and Blue Focus

Adjusting the red lens focus

- 1 Press the CUT OFF G and B keys to display the red signal only.
- 2 Loosen the R1 screw, slide it so that the letters H at the center of the screen is in focus, and then tighten the screw. *For details, see page 50 (E).*
- 3 Loosen the R2 screw, slide it so that the edge of the letter H at all four corners of the screen (pay attention to the gray areas illustrated below) are in focus, and then tighten the screw. Repeat steps 2 and 3 until the red focus adjustment is completed.

Proceed to adjust the red magnetic focus, AQP and DQP.

Adjusting the red magnetic focus, AQP and DQP

After adjusting the lens focus, adjust the magnetic focus, AQP and DQP. To adjust them, perform the same procedure as for the green focus adjustment.

For details, see "Adjusting the green magnetic focus" and "Adjusting the green AQP/DQP" on page 51 (E) to 53 (E).

Note

You do not have to adjust the red vertical and horizontal phase for the magnetic focus.

Proceed to adjust the blue focus.

Adjusting the blue lens focus

- 1 Press the CUT OFF G and R keys to display the blue signal only.
- 2 Loosen the B1 screw, slide it so that the letters H at the center of the screen is in focus, and then tighten the screw.
For details, see page 50 (E).
- 3 Loosen the B2 screw, slide it so that the edge of the letter H at all four corners of the screen (pay attention to the gray areas illustrated below) are in focus, and then tighten the screw.
Repeat steps 2 and 3 until the blue focus adjustment is completed.

Adjusting the blue magnetic focus, AQP and DQP

After adjusting the lens focus, adjust the magnetic focus, AQP and DQP. To adjust them, perform the same procedure as for the green focus adjustment.
For details, see "Adjusting the green magnetic focus" and "Adjusting the green AQP/DQP" on page 51 (E) to 53 (E).

Note

You do not have to adjust the blue vertical and horizontal phase for the magnetic focus.

Proceed to adjust the registration.

Adjusting the Registration

Procedure

- ① Mark the center of the screen. (page 57 (E))
↓
 - ② Set the remote control to the serviceman adjustment mode. (page 36 (E))
↓
 - ③ Select the NO INPUT mode. (page 57 (E))
↓
 - ④ Reset the data to the factory preset level. (Only if the adjustment data has been modified before) (page 88 (E))
↓
 - ⑤ Release the blanking adjustment. (page 59 (E))
↓
 - ⑥ Adjust the green registration. (page 61 (E))
 - 1 Centering adjustment
 - 2 SIZE and LIN adjustments
 - 3 SKEW and BOW adjustments
 - 4 KEY and PIN adjustments
 ↓
 - ⑦ Adjust the red registration. (page 68 (E))
 - 1 Centering adjustment
 - 2 SIZE and LIN adjustments
 - 3 SKEW and BOW adjustments
 - 4 KEY and PIN adjustments
 - 5 ZONE adjustments
 ↓
 - ⑧ Adjust the blue registration. (page 75 (E))
 - 1 Centering adjustment
 - 2 SIZE and LIN adjustments
 - 3 SKEW and BOW adjustments
 - 4 KEY and PIN adjustments
 - 5 ZONE adjustment
 ↓
 - ⑨ Adjust the blanking. (page 76 (E))
↓
 - ⑩ Save the adjusted data as the standard data. (page 77 (E))
↓
 - ⑪ Adjust fine for each input signal. (page 80 (E))
 - 1 Adjustment of RGB input signal
 - 2 White balance adjustment
 ↓
 - ⑫ Activate the protection of the remote control. (page 91 (E))
↓
 - ⑬ Adjust the picture. (page 92 (E))
↓
- Complete**

Preparation

- 1 Mark the center of the screen.
Measure the height and width of the screen to decide the center.
Marking five points with the white tape, as illustrated below, will help you adjust registration.

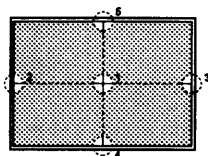

- 2 Set the remote control to the serviceman adjustment mode.
For details, see "For Remote Control" on page 36 (E).
- 3 Press the INPUT SELECT A or B key until "NO INPUT" appears.
Or, set the SWITCHER/INDEX select switch to SWITCHER and then press the number key from 1 to 8, corresponding to a line that is not connected to a signal.



- 4 Reset the data to the factory preset level.
(Only when you have adjusted the registration and have saved the adjustment data.)
For details, see "Resetting the Data" on page 88 (E).

Notes

- The center of the screen and the center of the cross hair pattern can be aligned by performing the centering adjustment.
For details, see "Green centering adjustment" on page 61 (E).
- When the optical axis angle is smaller, the hatch pattern becomes trapezoidal.
Perform the keystone adjustment to correct the distortion.
For details, see "Green KEY and PIN adjustments" on page 66 (E).

Adjusting the Registration

Keys for Adjusting

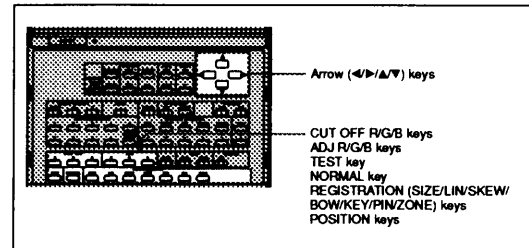

Indicated on the control	Adjustment Items
SIZE	Size
LN	Linearity
SKEW	Skew
BOW	Bow
KEY	Keystone
PIN	Pincushion
ZONE	Centering, zone

Releasing the Blanking

The registration adjustment is difficult if the entire test pattern is not visible. Follow the procedure below to make the whole test pattern visible.

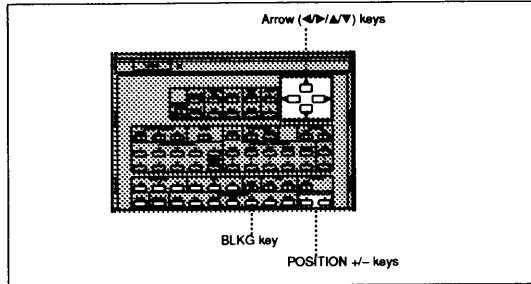

- 1 Press the BLKG key to enter the blanking adjustment mode.

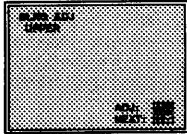

- 2 Press the TEST key to display the hatch pattern.
- 3 Press the POSITION +/- keys to select the part to be adjusted.
 - When you press the + key, the position cycles through the following order.
UPPER → LOWER → LEFT → RIGHT → UPPER → ...
 - When you press the - key, the position cycles in reverse order.

(Continued)

Adjusting the Registration

- 4 Press the arrow keys repeatedly until "Overflow!" appears on the screen for each position.

▲:UPPER ▼:LOWER ◀:LEFT ▶:RIGHT

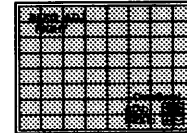

What is blanking?

Blanking is used to mask the picture. The picture size of this projector is adjusted at the factory to fit a 120-inch screen. Depending on the installation method, it is necessary to reduce or increase the masking to fit the picture to the screen. Here, reduce the masking to the minimum (the picture is projected at the largest size), and after the registration adjustment is complete, perform the blanking adjustment to fit the screen used.

Note

There may be a rainbow-like vertical band on the right side or a diagonal line on the upper part of the screen. They can be changed with the blanking adjustment later, leave them alone for now.

For details, see "Adjusting the Blanking" on page 76 (E).

Adjusting the Green Registration

Adjust the green registration first.

When adjusting green, do not greatly change the ZONE adjustment. If you change the green ZONE in the large range considerably, the adjustment for red and blue may be difficult.

Green centering adjustment

Adjust so that the center of the test pattern is aligned with the center of the screen.

- 1 Press the ZONE key.

The hatch pattern and the cursor appear.

If the cursor is not centered, use the POSITION key to center the cursor on the screen.

- 2 Press the ADJ G key.

- 3 Press the CUT OFF R and B keys to display green only.

- 4 Press the arrow keys to align the center of the hatch pattern with the center of the screen.

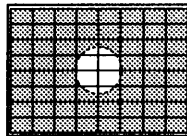

Notes

- For the green centering adjustment, the ZONE adjustment is only for the center zone.
- If the test pattern is off the center of the screen by a large amount, check that the ring spacers are adjusted correctly or that the projector is installed correctly.

Adjusting the Registration

Green SIZE and LIN (Linearity) adjustment

Adjust the picture size with respect to the screen, and the picture's up, down, left and right balance.

- 1 Press the LIN key.

You can also change to the 9 × 9 hatch pattern by pressing the TEST key.

- 2 Press the ADJ G key.

Pay attention only to the bold lines as illustrated below (the ends of the vertical and horizontal lines).

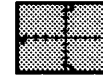

- 3 Adjust with the ◀ and ▶ keys until parts (⊙) on the right and left are of equal length.

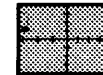

◀: The left and right vertical lines are shifted to the left while the vertical lines remain unmoved.

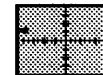

▶: The left and right vertical lines are shifted to the right while the vertical center lines remain unmoved.

- 4 Press the SIZE key.

- 5 Adjust with the ◀ and ▶ keys until parts (⊙) on the left and right are 15 to 20 mm long.

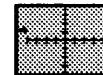

◀: The horizontal scale is reduced.

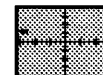

▶: The horizontal scale is expanded.

- 6 If they are not aligned, press the LIN key and repeat steps 3 to 5.

7 If the cross-hair pattern is off-centered on the screen, adjust the centering again and repeat steps 1 to 6 for the horizontal scale adjustment.
For details of the centering adjustment, see "Green centering adjustment" on page 61 (E).

8 Press the LIN key.

9 Adjust with the ▲ and ▼ keys until parts (ⓑ) at the top and bottom are equal length.

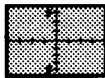

▲: The upper and lower horizontal lines are shifted upward while the horizontal center line remains unmoved.

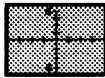

▼: The upper and lower horizontal lines are shifted downward while the horizontal center line remains unmoved.

10 Press the SIZE key.

11 Adjust with the ▲ and ▼ keys until parts (ⓐ) on the top and bottom are about 15 to 20 mm ($^{19}/_{32}$ to $^{13}/_{16}$ inches) long.

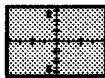

▲: The vertical scale is expanded.

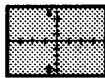

▼: The vertical scale is reduced.

12 If they are not aligned, repeat steps 8 to 11.

13 If the cross-hair pattern is off-centered on the screen, adjust the centering again and then repeat steps 8 to 12 for the vertical scale adjustment.
For details of the centering adjustment, see "Green centering adjustment" on page 61 (E).

14 After the adjustment is complete, press the MEMORY key to save the adjustment data.

Adjusting the Registration

Green SKEW and BOW adjustments

Display the cross pattern and adjust the bow-like or skew distortion of the horizontal and vertical center lines to make them parallel to the screen edges.

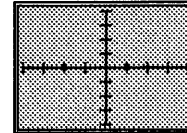

A Horizontal line adjustment

If the horizontal line of the picture is as shown by the dotted line in the illustrations below, adjust it with the corresponding arrow key so that it is perpendicular to the vertical line (bold line).

1 Press BOW key.

You can also change to the 9×9 hatch pattern by pressing the TEST key.

2 Adjust the distortion as illustrated below with the ▲ and ▼ keys.

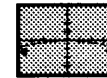

▲: The left and right ends of the horizontal line are adjusted so that they curve upward while the center remains unchanged.

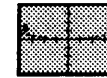

▼: The left and right ends of the horizontal line are adjusted so that they curve downward while the center remains unchanged.

3 Press the SKEW key.

4 Adjust the distortion as illustrated below with the ▲ and ▼ keys.

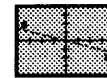

▲: The horizontal line rotates counter-clockwise, rotating around the center.

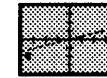

▼: The horizontal line rotates clockwise, rotating around the center.

5 Repeat steps 1 to 4 until the horizontal lines become parallel to the screen's edges.

6 When the adjustment is complete, press the MEMORY key to save the adjustment data.

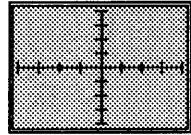

B Vertical line adjustment

If the vertical line of the picture is as shown by the dotted line in the illustrations below, adjust it with the corresponding arrow key so that it is perpendicular to the horizontal line (bold line).

- 1 Press BOW key.
You can also change to the 9 × 9 hatch pattern by pressing the TEST key.

- 2 Adjust the distortion as illustrated below with the ◀ and ▶ keys.

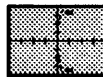

◀: The upper and lower ends of vertical the line are adjusted so that they curve towards the left while the center remains unchanged.

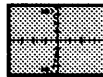

▶: The upper and lower ends of the vertical line are adjusted so that they curve towards the right while the center remains unchanged.

- 3 Press the SKEW key.

- 4 Adjust the distortion as illustrated below with the ◀ and ▶ keys.

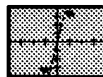

◀: The vertical line rotates counter-clockwise, rotating around the center.



▶: The vertical line rotates clockwise, rotating around the center.

- 5 Repeat steps 1 to 4 until the vertical lines become parallel to the screen's edges.

- 6 After the adjustment is complete, press the MEMORY key to save the adjustment data.

Adjusting the Registration

Green KEY (keystone) and PIN (pincushion) adjustments

Adjust the trapezoidal distortion and the pin-cushion distortion in the vertical and horizontal directions.

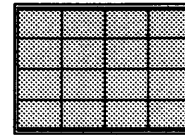

A Horizontal line adjustment

If the picture's borders are as shown by the dotted line in the illustrations below, adjust it with the corresponding arrow key so that they are parallel (bold line).

- 1 Press KEY key.
You can also change to the 9 × 9 hatch pattern by pressing the TEST key.

- 2 Adjust the distortion as illustrated below with the ▲ and ▼ keys.

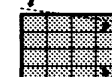

▲: The lines spread apart on the right side and come together on the left side while the center remains unmoved.

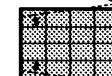

▼: The lines spread apart on the left side and come together on the right side while the center remains unmoved.

- 3 Press the PIN key.

- 4 Adjust the distortion as illustrated below with the ▲ and ▼ keys.

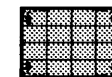

▲: The ends of the top and bottom lines spread apart while the center remains unmoved.

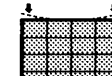

▼: The ends of the top and bottom lines come together while the center remains unmoved.

- 5 Repeat steps 1 to 4 until the horizontal lines become parallel to the screen edges.

- 6 After the adjustment is complete, press the MEMORY key to save the adjustment data.

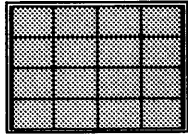

E Vertical line adjustment

If the picture's borders are as shown by the dotted line in the illustrations below, adjust it with the corresponding arrow key so that they are parallel (bold line).

1 Press the KEY key.

2 Adjust the distortion as illustrated below with the ◀ and ▶ keys.

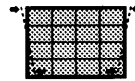

◀: The lines spread apart at the bottom and come together at the top while the center remains unmoved.

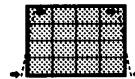

▶: The lines spread apart at the top and come together at the bottom while the center remains unmoved.

3 Press the PIN key.

4 Adjust the distortion as illustrated below with the ◀ and ▶ keys.

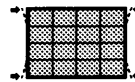

◀: The ends of the left and right side lines come together while the center remains unmoved.

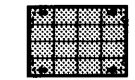

▶: The ends of the left and right lines spread apart while the center remains unmoved.

5 Repeat steps **1** to **4** until the vertical lines become parallel to the screen edges.

6 After the adjustment is complete, press the MEMORY key to save the adjustment data.

The green registration adjustment is all completed. Proceed to the adjustment for the red signal.

Adjusting the Registration

Adjusting the Red Registration

Adjust the red signal so that it converges with the green signal and is seen as yellow.

Red centering adjustment

Adjust so that the red test pattern center is aligned with that of the green pattern.

1 Press the ZONE key.

The hatch pattern and the cursor appear.

If the cursor is not centered, press the POSITION key so that the cursor position is at the center of the screen.

2 Press the ADJ R key.

3 Press the CUT OFF B key to display green and red.

4 Press the arrow keys to align the red hatch pattern center with that of the green pattern.

Note

At this time, adjust the ZONE for the center zone only.

Red SIZE and LIN (linearity) adjustments

1 Press the LIN key.

You can also change to the 9 × 9 hatch pattern by pressing the TEST key.

2 Press the ADJ R key.

Pay attention only to the encircled portions in the illustrations below.

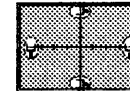

3 Adjust with the ◀ and ▶ keys until the parts (⊙) on the left and right are of equal length.

◀: The left and right vertical lines are shifted to the left while the vertical center line remains unmoved.

▶: The left and right vertical lines are shifted to the right while the vertical center line remains unmoved.

4 Press the SIZE key.

- 5 Adjust with the ◀ and ▶ keys so that the red and green lines in the right and left encircled portions converge.
 - ◀: The horizontal scale is reduced.
 - ▶: The horizontal scale is expanded.
- 6 If the lines do not converge, press the LIN key and then repeat steps 3 to 5.
- 7 If the cross-hair pattern is off-centered on the screen, adjust the centering again and repeat steps 1 to 6 for the horizontal scale adjustment.

For details of the centering adjustment, see "Red centering adjustment" on page 68 (E).
- 8 Press the LIN key.
- 9 Adjust with the ▲ and ▼ keys until parts (ⓐ) at the top and bottom are of equal length.
 - ▲: The upper and lower horizontal lines are shifted upward while the horizontal center line remains unmoved.
 - ▼: The upper and lower horizontal lines are shifted downward while the horizontal center line remains unmoved.
- 10 Press the SIZE key.
- 11 Adjust with the ▲ and ▼ keys so that the red and green lines at the top and bottom circled portions converge.
 - ▲: The vertical scale is expanded.
 - ▼: The vertical scale is reduced.
- 12 If the lines do not converge, repeat steps 8 to 11.
- 13 If the cross-hair pattern is off-centered on the screen, adjust the centering again and repeat steps 8 to 12 for the vertical scale adjustment.

For details of the centering adjustment, see "Red centering adjustment" on page 68 (E).
- 14 After the adjustment is complete, press the MEMORY key to save the adjustment data.

Adjusting the Registration

Red SKEW and BOW adjustments

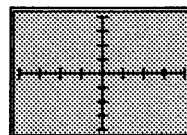

A Horizontal line adjustment

If the horizontal line of the picture is as shown by the dotted line in the illustrations below, adjust it with the corresponding arrow key so that it is perpendicular to the vertical line (bold line).

- 1 Press BOW key. You can also change to the 9 × 9 hatch pattern by pressing the TEST key.

- 2 Adjust the distortion as illustrated below with the ▲ and ▼ keys.

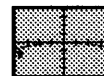

▲: The left and right ends of the horizontal line are adjusted so that they curve upward while the center remains unchanged.



▼: The right and left ends of the horizontal line are adjusted so that they curve downward while the center remains unchanged.

- 3 Press the SKEW key.

- 4 Adjust the distortion as illustrated below with the ▲ and ▼ keys.



▲: The horizontal line rotates counter-clockwise, rotating around the center.



▼: The horizontal line rotates clockwise, rotating around the center.

- 5 Repeat steps 1 to 4 until the red horizontal line converges with the green line.
- 6 When the adjustment is complete, press the MEMORY key to save the adjustment data.

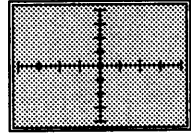

B Vertical line adjustment

If the vertical line of the picture is as shown by the dotted line in the illustrations below, adjust it with the corresponding arrow key so that it is perpendicular to the vertical line (bold line).

- 1 Press BOW key.
You can also change to the 9 × 9 hatch pattern by pressing the TEST key.

- 2 Adjust the distortion as illustrated below with the ◀ and ▶ keys.

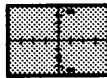

◀: The upper and lower ends of the vertical line are adjusted so that they curve towards the left while the center remains unchanged.

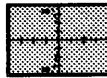

▶: The upper and lower ends of the vertical line are adjusted so that they curve towards the right while the center remains unchanged.

- 3 Press the SKEW key.

- 4 Adjust the distortion as illustrated below with the ◀ and ▶ keys.

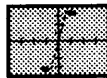

◀: The vertical line rotates counter-clockwise, rotating around the center.

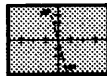

▶: The vertical line rotates clockwise, rotating around the center.

- 5 Repeat steps 1 to 4 until the red vertical line converges with the green line.

- 6 When the adjustment is complete, press the MEMORY key to save the adjustment data.

Adjusting the Registration

Red KEY (keystone) and PIN (pincushion) adjustments

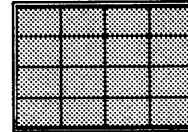

A Horizontal line adjustment

If the picture's borders are as shown by the dotted line in the illustrations below, adjust it with the corresponding arrow key so that they are parallel (bold line).

- 1 Press the KEY key.
You can also change to the 9 × 9 hatch pattern by pressing the TEST key.

- 2 Adjust the distortion as illustrated below with the ▲ and ▼ keys.



▲: The lines spread apart on the right side and come together on the left side while the center remains unmoved.



▼: The lines spread apart on the left side and come together on the right side while the center remains unmoved.

- 3 Press the PIN key.

- 4 Adjust the distortion as illustrated below with the ▲ and ▼ keys.

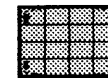

▲: The ends of the top and bottom lines spread apart while the center remains unmoved.

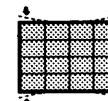

▼: The ends of the top and bottom lines come together while the center remains unmoved.

- 5 Repeat steps 1 to 4 until the red horizontal lines converge with the green lines.

- 6 After the adjustment is complete, press the MEMORY key to save the adjustment data.

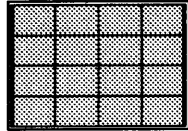

E Vertical line adjustment

If the picture's borders are as shown by the dotted line in the illustrations below, adjust it with the corresponding arrow key so that they are parallel (bold line).

- 1 Press the KEY key.
You can also change to the 9 × 9 hatch pattern by pressing the TEST key.
- 2 Adjust the distortion as illustrated below with the ◀ and ▶ keys.
 - ◀: The lines spread apart at the bottom and come together at the top while the center remains unmoved.
 - ▶: The lines spread apart at the top and come together at the bottom while the center remains unmoved.
- 3 Press the PIN key.
- 4 Adjust distortion as illustrated below with the ◀ and ▶ keys.
 - ◀: The ends of the left and right side lines come together while the center remains unmoved.
 - ▶: The ends of the left and right lines spread apart while the center remains unmoved.
- 5 Repeat steps 1 to 4 until the vertical lines converge with the green lines.
- 6 After the adjustment is complete, press the MEMORY key to save the adjustment data.

Adjusting the Registration

Red ZONE adjustment

Adjust ZONE after the red lines have converged with the green lines. Before adjusting ZONE, you should have completed the adjustments described in pages 68 (E) to 73 (E).

- 1 Press the ZONE key.
The hatch pattern and the cursor appear.

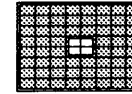

- 2 Press the POSITION key to select the part to be adjusted.

When you press the + key, the cursor moves in the numerical order as illustrated.
When you press the - key, the cursor moves in the reverse order. The selected position number appears in the upper right corner.

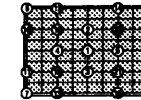

- 3 Adjust the red line distortion in the cursor positioning area with the arrow keys.
- 4 After the adjustment is complete, press the MEMORY key to save the adjustment data.

The registration adjustment is complete.
Proceed to the registration adjustment of the blue signal.

Adjusting the Blue Registration

Adjust the blue signal so that it converges with the red signal which has been adjusted. When the blue and red test patterns converge, the pattern is seen as magenta.

Blue centering adjustment

Adjust so that the blue test pattern center is aligned with that of the red pattern.

- 1 Press the ZONE key.

The hatch pattern and the cursor appear.

If the cursor is not centered, press the POSITION key so that the cursor position is at the center of the screen.

- 2 Press the ADJ B key.
- 3 Press the CUT OFF G key to display blue and red.
- 4 Press the arrow keys to align the blue hatch pattern center with that of the green pattern.

Note

At this time, adjust the ZONE for center zone only.

Blue SIZE, LIN (linearity), SKEW, BOW, KEY (keystone), PIN (pincushion) and ZONE adjustments

Adjust so that the blue signal converges with the red signal in each adjustment. The procedures are the same as for adjusting the red registration.

For details, see pages 68 (E) to 74 (E).

Make sure that "ADJ B" appears on the screen when adjusting the blue signal.

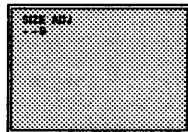

After the blue adjustment is complete, press the MEMORY key to save the adjustment data.

Adjusting the Registration

Adjusting the Blanking

After adjusting the registration, adjust the blanking to erase the rainbow-like vertical band on the right side or a diagonal line in the upper part of the screen.

- 1 Press the BLKG key.

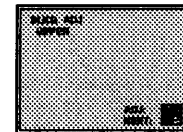

- 2 Press the TEST key to display the hatch pattern.

- 3 Press the POSITION +/- key to select the part to be adjusted.

- When you press the + key, the position cycles through the following order:

UPPER → LOWER → LEFT → RIGHT → UPPER ...

- When you press the - key, the position cycles in reverse order.

- 4 Adjust with the arrow keys.

- Press the ▲ and ▼ keys to adjust the UPPER and LOWER parts.

The diagonal line in the upper part will disappear with the UPPER adjustment.

- Press the ◀ and ▶ keys to adjust the LEFT and RIGHT parts.

The rainbow-like vertical band on the right side will disappear with the RIGHT adjustment.

- 5 After the adjustment is complete, press the MEMORY key to save the adjustment data.

Saving the Standard Registration Data

After adjusting all the registrations for the green, red and blue signals, save the adjustment data as the standard data for the projector.

- 1 Press the MEMORY key and release it.

The adjustment data is saved in the memory as an internal signal with a horizontal frequency of approximately 34 kHz.



- 2 Hold down the MEMORY key for more than 3 seconds.

The message appears and the projector enters the standard data saving mode.

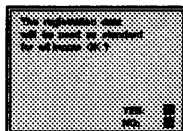

- 3 Press the ▲ key (for YES).

All the registration data will be converted into the internal signal data and are saved as standard data.

Notes

- All keys except for the MEMORY key do not function while saving the data.
- If the adjustment data is saved as the standard data, the registration data with other horizontal frequencies will be converted into the standard data if they have not been saved before.

Adjusting the Registration

Memory structure

This projector saves the adjustment data in one of eight memory blocks, on the horizontal frequency of the input signal. The divided registration memory blocks are provided for each of acceptable horizontal frequency, as below.

Registration memory block	Horizontal frequency (Hz)
1	15 kHz – 20 kHz
2	20 kHz – 32 kHz
3	32 kHz – 45 kHz
4	45 kHz – 58 kHz
5	58 kHz – 73 kHz
6	73 kHz – 85 kHz
7	85 kHz – 105 kHz
8	105 kHz – 135 kHz

When a signal is input, the projector automatically recognizes its horizontal frequency and selects the appropriate memory blocks.

When adjusting registrations without input signal, the registration is adjusted with the projector's internal signal; horizontal frequency of approximately 34 kHz. So the adjustment data is saved in registration memory block 3, in this case.

If the adjustment data is saved as the standard data, the factory preset data for all of the memory blocks will be changed to reflect the new settings. Since the standard data in the current installation condition is saved, you can easily adjust each input signal next time.

The following steps show the typical procedure for how to use the standard data and when to save the data.

- 1 After installation, adjust registrations without an input signal and save the adjustment data.
- 2 Save the adjustment data as the standard data.
- 3 Adjust for each input signal and save the adjustment data.

For reference – Memory architecture

	Contents	Data source	How to save the data
Channel memory	Picture control	Input channel	Press the MEMORY key. Switch the input connector. Turn the projector off with the remote control.
Status memory	RGB SIZE, SHIFT Blanking Clump Color temperature V-SHIFT	H/ V frequency of the input signal Sync signal status	Press the MEMORY key. Turn the projector off with the remote control.
Registration memory	Registration Magnetic focus	Registration memory block (Horizontal frequency of the input signal)	Press the MEMORY key. Switch the input connector. Change the horizontal frequency.
Color temperature memory	W/B Bias and gain	Color temperature setting	Turn the projector off with the remote control.

One projector can store only one value in memory for AQP, DQP, baud rate, CRT timer and STATUS ON/OFF.

Note

After the adjustment is complete, be sure to press the MEMORY key or turn the projector off with the remote control.

Fine Adjustment for Each Input Signal

After the registration adjustment is performed without an input source and the adjustment data is saved as the standard data, input an external signal and fine adjust for each input signal.

Adjusting the Video Input Signal

- 1 Connect to the PC-1271M Signal Interface Switcher with the IFB-1000 Signal Interface Board.
- 2 Set the SWITCHER/INDEX select switch to SWITCHER, and then designate the input source number by pressing the number keys from 1 to 8.
- 3 Press the PAGE key repeatedly until PAGE 4 appears. Check that the horizontal frequency of the input signal ("fH") indicates 15.7 kHz.
- 4 Adjust the magnetic focus for each input signal.

Fine magnetic focus adjustment

- 1 Press the TEST key to display the H pattern.
- 2 If necessary, fine adjust the magnetic focus.
For details of the adjustment procedure, see "Adjusting the green magnetic focus" on page 51 (E).
- 3 Press the MEMORY key to save the adjustment data.

Notes

- Do not hold down the MEMORY key for a few seconds.
- When you adjust the input signal corresponding to the registration memory blocks 1 and 2, the blue and red magnetic focus automatically becomes out of focus immediately after the magnetic focus adjustment mode is canceled. With this function, you can obtain the picture which has the optimized white/black balance.
- When you give priority to the spot focus over the white balance of the picture, adjust the magnetic focus to the level you can get by subtracting the value listed in the table below from the optimized magnetic focus level.

	Color temperature							
	9300		6500		5400		3200	
Values of magnetic focus	BLUE ALL	RED ALL	BLUE ALL	RED ALL	BLUE ALL	RED ALL	BLUE ALL	RED ALL
Block 1	+40	-10	+40	-10	+40	-10	±0	-10
Block 2	+20	±0	+20	±0	+20	±0	±0	±0

Example

- Color temperature: 9300
 - Registration memory block: block 1
 - Red adjustment focus level: 130
- To optimize the picture, subtract the value above from the adjustment level.
 $130 - (-10) = 140$
 Therefore, adjust the red magnetic focus level to 140.

Fine registration adjustment

- 1 Press the TEST key to display the hatch pattern.
- 2 If necessary, fine adjust the registrations.
For details of the adjustment procedure, see "Adjusting the Registration" on pages 56 (E) to 79 (E).
- 3 Press the MEMORY key to save the adjustment data.

SIZE adjustment

Adjust the picture size if it does not fit on the screen.

- 1 Press the RGB SIZE key.
- 2 Adjust the picture size with the arrow keys.
 - ▲: The vertical size is expanded.
 - ▼: The vertical size is reduced.
 - : The horizontal size is expanded.
 - ◄: The horizontal size is reduced.
- 3 Press the MEMORY key to save the adjustment data.

Blanking adjustment

If the displayed picture is larger than the screen, cut off the excess parts.

- 1 Press the BLKG key.
- 2 Press the POSITION +/- key to select the part to be adjusted.
 - When you press the + key, the position cycles through the following order:
UPPER → LOWER → LEFT → RIGHT → UPPER...
 - When you press the - key, the position cycles in reverse order.
- 3 Adjust with the arrow keys.
 - Press the ▲ and ▼ keys to adjust the UPPER and LOWER positions.
 - Press the ◄ and ► keys to adjust the LEFT and RIGHT positions.
- 4 Press the MEMORY key to save the adjustment data.

Note

When you connect multiple video input sources to the projector, such as the switcher, adjust the picture size and blanking for each signal input source.

Fine Adjustment for Each Input Signal

Adjusting the RGB Input Signal

- 1 Connect to the RGB IN connector on the projector or the PC-1271M Signal Interface Switcher with the optional interface board.
- 2 Press the INPUT SELECT A or B key on the remote control. Or, set the SWITCHER/INDEX select switch to SWITCHER, and then designate the input source number by pressing the number keys from 1 to 8.
- 3 Press the PAGE key repeatedly until PAGE 4 appears to check the horizontal frequency ("fH") of the input signal.
If "fH" shows 32 - 45 kHz (the range of registration memory block 3), you do not need to fine adjust.
- 4 Adjust the magnetic focus for each input signal.
For details, see "Adjusting the green magnetic focus" on page 51 (E).

Fine magnetic focus adjustment

- 1 Press the TEST key to display the H pattern.
- 2 If necessary, fine adjust the magnetic focus.
For details of the adjustment procedure, see "Adjusting the green magnetic focus" on page 51 (E).
- 3 Press the MEMORY key to save the adjustment data.

Fine registration adjustment

- 1 Press the TEST key to display the hatch pattern.
- 2 If necessary, fine adjust registrations.
For details of the adjustment procedure, see "Adjusting the Registration" on pages 56 (E) to 79 (E).
- 3 When you connect the multiple RGB input sources, group them according to the horizontal frequency by checking the "fH" on PAGE 4.
- 4 Fine adjust registrations for each group.
Press the MEMORY key and release it to save the adjustment data.
The adjusted data will be saved normally.

Hint for the adjustment

The projector saves the registration adjustment data in one of eight registration memory blocks according to the horizontal frequency of the input signals. (For details, see "Memory structure" on page 78 (E).) When multiple signals are used, you need to fine adjust registrations for each block. If multiple input signal are grouped into the same memory block, adjust for any one of them. You can check in which block the signal is grouped with PAGE 4. (For details, see page 43 (E).)

RGB SIZE adjustment

Adjust the picture size if it does not fit the screen.

- 1 Press the RGB SIZE key.
- 2 Adjust the picture size with the arrow keys.
 - ▲: The vertical size is expanded.
 - ▼: The vertical size is reduced.
 - : The horizontal size is expanded.
 - ◄: The horizontal size is reduced.

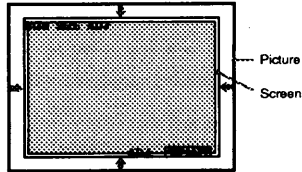

- 3 Press the MEMORY key to save the adjustment data.

Fine Adjustment for Each Input Signal

RGB SHIFT adjustment

If the picture needs to be shifted to fit on the screen, adjust the RGB SHIFT.

- 1 Press the RGB SHIFT key.
- 2 Adjust the shift with the arrow keys.
 - ▲: The picture size is shifted upward.
 - ▼: The picture size is shifted downward.
 - ◄: The picture size is leftward.
 - : The picture size is rightward.

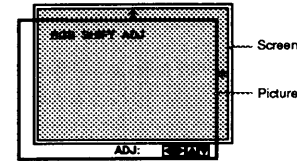

- 3 Press the MEMORY key to save the adjustment data.

Blanking adjustment

If the displayed picture is larger than the screen, cut off the excess parts.

- 1 Press the BLKG key.
- 2 Press the POSITION +/- key to select the part to be adjusted.
 - When you press the + key, the position cycles through the following order:
UPPER → LOWER → LEFT → RIGHT → UPPER ...
 - When you press the - key, the position cycles in reverse order.
- 3 Adjust with the arrow keys.
 - Press the ▲ and ▼ keys to adjust the UPPER and LOWER positions.
 - Press the ◄ and ► keys to adjust the LEFT and RIGHT positions.
- 4 Press the MEMORY key to save the adjustment data.

Note

When you connect multiple video input sources to the projector, such as the switcher, adjust the picture size, shift and blanking for each RGB signal that needs different characteristics. The characteristics are shown in PAGE 4.

Adjusting the White Balance

The color temperatures are preset at the factory to 9300K, 6500K, 5400K and 3200K. However, if you change these levels or set a color temperature other than the factory-preset levels, you can adjust the white balance and save it in the memory.

Setting the white balance

- 1 Display the same input signal on the projector and the color monitor.
- 2 Press the PAGE key repeatedly until PAGE 3 appears.

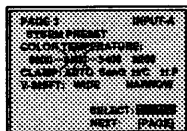

- 3 Press the arrow key to select 9300, 6500, 5400 or 3200, the nearest color temperature to that of the color monitor or the desired one. Normally set to 6500. Select the appropriate color temperature according to your application and the picture source.
- 4 Press the MEMORY key to save the adjustment data.

Adjusting the white balance

If you wish to make the color of a particular input signal (eg.HDTV system picture) uniform to that of the color monitor, you can adjust the white balance.

Display the same input signal on the projector and the monitor.

Adjusting the black level

- 1 Press the W/B BIAS key.

The PLUGE pattern appears.
The contrast and the brightness levels of the projector are automatically set to 80 and 50 respectively.

- 2 Hold down the TEST key for more than 5 minutes.

"WHITE BALANCE BIAS ADJ" appears at the upper left of the screen.

- 3 Press the ADJ R, G or B key to select the color to be adjusted. When selecting the color, pay attention to the black part of the picture displayed on the screen and note which color stands out compared to that of the monitor.

(Continued)

Fine Adjustment for Each Input Signal

- 4 Press the ◀ or ▶ key so that the black part in the picture on the screen looks the same as that of the monitor.
If the brightness of that part does not look the same as that of the monitor, adjust the other colors by pressing the ADJ R, G or B key and arrow keys.

- 5 Press the MEMORY key to save the adjustment data.

Adjusting the white level

- 1 Press the W/B GAIN key.

The window pattern appears.
The contrast and the brightness levels of the projector are automatically set to 80 and 50, respectively.

- 2 Hold down the TEST key for more than 5 minutes.

"WHITE BALANCE GAIN ADJ" appears at the upper left of the screen.

- 3 Press the ADJ R, G or B key to select the color to be adjusted. When selecting the color, pay attention to the white part of the picture displayed on the screen and note which color stands out compared to that of the monitor.

- 4 Press the ◀ or ▶ key so that the white part in the picture on the screen looks the same as that of the monitor.
If the brightness does not look the same as that of the monitor, adjust the other colors by pressing the ADJ R, G or B key and the arrow keys.

- 5 Press the MEMORY key to save the adjustment data.

When using multiple projectors

Input the same signal to the based projector and the projector to be adjusted.

Set COLOR TEMPERATURE on PAGE 3 display to the same position on both projectors, and then operate the procedures described above to make the black and white colors uniform between the based projector and the projector to be adjusted.

Notes

- When adjusting the white balance, use the external color monitor for the reference of the color.
- To adjust the white balance easily, set the STATUS in the PAGE 1 to OFF so that the on-screen display disappears when adjusting the white balance.
- You can adjust the white balance more easily if you set the COLOR level to MIN to display the black and white picture.

Correcting the Luminance of the Picture – Clamp Setting

Clamp is used as a standard for setting the black level of the picture correctly. The standard position of the clamp depends on the kind of the sync signal. Normally the CPU judges the signal and sets the clamp position automatically. However, the CPU may misjudge the signal because of noise. If the luminance of the picture seems to be incorrect (too dark, the black color is too light, or the luminance is unstable), the clamp position may need to be changed. Change the clamp position following the procedure below.

- 1 Press the PAGE key repeatedly until the PAGE 3 appears.

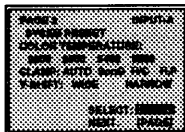

- 2 Select the clamp position by pressing the ◀, ▶, ▲ and ▼ keys.
AUTO: Automatic setting mode. Normally, set to this position.
S on G: If the black color is too light or seems to be green, set to this position.
H/C: If the picture is too dark or the luminance is unstable, set to this position.
H.P: If the luminance is still incorrect after changing the clamp setting to "S on G" or "H/C", set to this position and perform the H-SHIFT adjustment.
- 3 Press the MEMORY key to store the adjustment data.

If the luminance is still incorrect after changing the clamp setting

There may be a problem with the input signal or the connection. Check the input signal.

Resetting the Data

There are two ways to reset the data; the data reset and factory preset value.

Data reset

The data is reset to the previously saved data (the data before the adjustment).

Factory preset

The data is reset to the factory preset value. You can reset to the factory preset values only after a data reset.

Resetting the Data

- 1 Select the adjustment mode to be reset.
- 2 Press the ◀ and ▶ keys simultaneously.

The following display appears.

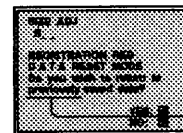

Check that "previously" appears here. (eg. To reset all the red indication adjustment data to the previously saved data)

- 3 Press the ▲ key.

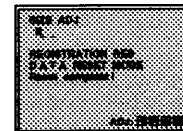

All the red registration adjustment data will be reset to the previously saved data. (Previous data reset)

- 4** Press the ◀ and ▶ keys simultaneously again.

The following display appears.

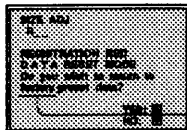

Check that "factory" appears here. (eg. To reset all the red indication adjustment data to the factory preset level)

- 5** Press the ▲ key.

All red registration adjustment data will be reset to the factory preset level.
(Factory preset)

Resetting the Standard Data to the Factory Preset Levels

If you wish to adjust and save the registration data, reset the data to the factory preset levels before adjusting the registration.

- 1** Press the CENT R and B keys simultaneously to enter the green centering adjustment mode.
- 2** Follow the steps **2** to **5** on pages 88 (E) to 89 (E).

The centering adjustment data of the red, green and blue signals are reset to the factory preset levels.
- 3** Press the SIZE key.
- 4** Press the ADJ G key, and then execute the factory preset.

The SIZE, LIN, SKEW, BOW, KEY, PIN and ZONE adjustment data of the green signal is reset to the factory preset levels.
- 5** Press the ADJ R key, and then execute the factory preset.

The SIZE, LIN, SKEW, BOW, KEY, PIN and ZONE adjustment data of the red signal are reset to the factory preset levels.
- 6** Press the ADJ B key, and then execute the factory preset.

The SIZE, LIN, SKEW, BOW, KEY, PIN and ZONE adjustment data of the blue signal are reset to the factory preset levels.
- 7** Press the BLKG key.

(Continued)

Resetting the Data

- 8** Press the TEST key, and then execute the factory preset.

The UPPER, LOWER, LEFT and RIGHT blanking adjustment data are reset to the factory preset levels.

The standard data are reset to the factory preset levels.
Then start adjusting the registration.

For reference – Mode data reset correspondence

Mode	Data to be reset
RGB size	H-size and V-size
RGB shift	H-shift and V-shift
G-centering	Centering data for all colors
R-centering	Not applicable
B-centering	Not applicable
Size, Linearity Skew, Bow Keystone Pincushion	All the registration data for the selected color (including the Zone data)
Zone	Zone data for the selected color is set to the middle adjustment level (128).
Blanking	UPPER/LOWER/LEFT/RIGHT side blanking data
Gain, Bias	All the Bias and Gain data for all colors at the current color temperature
Magnetic focus	Magnetic focus data for the memory block corresponding to the current horizontal frequency (fH)
AQP/DQP	All the AQP/DQP data

ZONE data reset

The ZONE data reset allows to set the ZONE data of all the positions to 128, middle adjustment level. Reset the ZONE data if wavelike distortion occurs with the outermost line of the hatch pattern or the red and blue lines do not converge when adjusting registration (only when the projector is not installed on the floor using a 120-inch front type screen). After resetting the ZONE data, adjust the KEY and PIN and then adjust the ZONE again.

Protecting the Setting

When you turn off the projector with the remote control, the adjustment keys become inoperable in order to prevent the users from accidentally changing the registration adjustments. It is also possible to make the keys inoperable while the power is on in the following way.

- 1 Hold down the NORMAL key for at least 3 seconds.

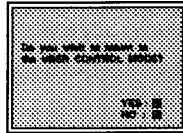

- 2 Press the ▲ key.

The adjustment keys are now inoperable.

Adjusting the Picture Quality

Adjust the picture for your preference. The adjustment data can be saved in the memory.

- 1 Adjust with the PICTURE CONTROL +/- keys.

CONTR	Picture contrast
COLOR	Color intensity
BRT	Brightness
SHARP	Sharpness
HUE	Hue

The adjustment levels are digitally displayed with a range of MIN, 1, 2, ... 99, MAX.

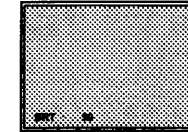

- 2 Press the MEMORY key to save the data.

Restoring the factory preset levels

Press the RESET key.

The factory preset levels appear on the screen.

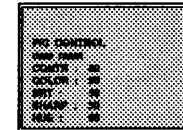

Notes

- The COLOR, SHARP and HUE keys do not function on the pictures input from the RGB IN connectors.
- The HUE and COLOR keys do not function if the input signal is black and white.
- The HUE key does not function with the PAL or SECAM color input source.

Dynamic picture mode (only for the video input pictures)

You can get high quality picture contrast by switching the DYNAMIC PIC SW or the BA board.

For details, see "Setting the Dynamic Picture" on page 25 (E).

Changing the Initialization Period

You can set the desired warm up time for the projector in 1 minute increments.

- 1 Set the remote control to the serviceman adjustment mode.
For details, see "For Remote Control" on page 36 (E).
- 2 Hold down the POWER ON key on the remote control for 5 seconds.

The following display appears.

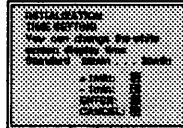

- 3 Press the ◀ and ▶ keys to set the desired minutes.
◀: Increases by 1 minute.
▶: Decreases by 1 minute.

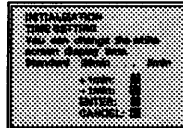

- 4 Press the ▲ key.

The display disappears.

To cancel the setting

Press the ▼ key instead of the ▲ key in step 4 above.

To set it so that the signal input from the connected equipment appears on the screen immediately after the power is turned on
Set the initializing period to "0 min".

Turning off the "OFF" indication on the Screen

Even when you set "STATUS" setting in the PAGE 1 to OFF, "OFF" indication is still displayed on the screen.
To turn it off, follow the procedure below.

- 1 Press the PAGE key until the PAGE 1 display appears.
- 2 Press the STATUS OFF key.
- 3 Hold down the STATUS OFF key for more than 5 seconds.

An asterisk (*) appears as illustrated below.

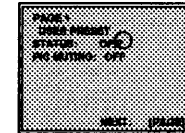

Asterisk (*) appears.

To turn on "OFF" indication

Press the STATUS OFF key until the asterisk (*) disappears.

List of Messages

Use the list below to check the meaning of the messages displayed on the screen. The list is divided into sections according to the location which the message appears. First check the location in the following diagram, then refer to the alphabetic listing to find the message.

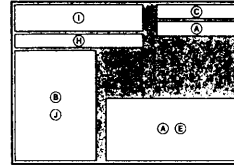

①, ②, ③ and ④ listed below appear all over on the screen.

A Caution messages

• Not applicable!	• The key does not function in the current mode.
• Overflow!	• The setting is outside the adjustable range limits.
• PIC MUTING	• Picture muting mode is on.
• Input is not VIDEO.	• The input signal is not VIDEO.
• Input is not NTSC.	• The input signal is not NTSC.
• Input is not RGB.	• The input signal is not RGB.
• Input is B & W.	• The input signal is black and white.
• OFF	• On-screen display STATUS is set to OFF.
• NO INPUT	• No input signal
• Overcorrection	• When adjusting registrations, some settings are overcorrected.

B PIC CONTROL data

• CONTR (CONTRAST)	• Contrast
• COLOR	• Color
• BRT (BRIGHTNESS)	• Brightness
• SHARP (SHARPNESS)	• Sharpness
• HUE	• Hue
• PIC CONTROL data reset	• Resets the PIC CONTROL data.

C Input signal

• VIDEO	• Input from VIDEO IN
• INPUT-A	• Input from RGB IN
• INPUT-B	• Input from an optional interface board
• SW'ER x-y (switcher x=1-2, y=1-8)	• Input from an optional switcher
• ID No.xx	• The ID number of the optional IFB-101 (when the IFB-101 is installed.)
• OTHER	• An optional switcher is in the OTHER mode.

List of Messages

Use the list below to check the meaning of the messages displayed on the screen. The list is divided into sections according to the location which the message appears. First check the location in the following diagram, then refer to the alphabetic listing to find the message.

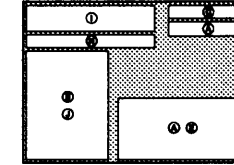

①, ②, ③ and ④ listed below appear all over on the screen.

A Caution messages

• Not applicable!	• The key does not function in the current mode.
• Overflow!	• The setting is outside the adjustable range limits.
• PIC MUTING	• Picture muting mode is on.
• Input is not VIDEO.	• The input signal is not VIDEO.
• Input is not NTSC.	• The input signal is not NTSC.
• Input is not RGB.	• The input signal is not RGB.
• Input is B & W.	• The input signal is black and white.
• OFF	• On-screen display STATUS is set to OFF.
• NO INPUT	• No input signal
• Overcorrection	• When adjusting registrations, some settings are overcorrected.

B PIC CONTROL data

• CONTR (CONTRAST)	• Contrast
• COLOR	• Color
• BRT (BRIGHTNESS)	• Brightness
• SHARP (SHARPNESS)	• Sharpness
• HUE	• Hue
• PIC CONTROL data reset	• Resets the PIC CONTROL data.

C Input signal

• INPUT-A	• Input from RGB IN
• INPUT-B	• Input from an optional interface board
• SW'ER x-y (switcher x=1-2, y=1-8)	• Input from an optional switcher
• ID No.xx	• The ID number of the optional IFB-101 (when the IFB-101 is installed.)
• OTHER	• An optional switcher is in the OTHER mode.

VPH-1292Q/QM MODEL ONLY

List of Messages

D PAGE

Subtitle

• USER PRESET	• User preset
• USER CONTROL	• User control
• SYSTEM PRESET	• System preset
• INPUT INFO (INPUT INFORMATION)	• Input information

PAGE 1

• STATUS ON/OFF	• On-screen display on/off
• PIC MUTING ON/OFF	• Picture muting mode on/off

PAGE 2

• CONTR (CONTRAST)	• Contrast
• COLOR	• Color
• BRT (BRIGHTNESS)	• Brightness
• SHARP (SHARPNESS)	• Sharpness
• HUE	• Hue
• PIC CONTROL data reset	• Resets the PIC CONTROL data.

PAGE 3

• COLOR TEMPERATURE: 9300/6500/5400/3200	• Color temperature is set to 9300/6500/5400/3200 manually adjusted by Qualified Sony Service Personnel.
• CLAMP: AUTO / S on G / H/C / H.P	• Clamp position is set to automatic/internal/external sync signal/horizontal deflection pulse position.
• V-SHIFT: WIDE/NARROW	• The adjustable range of vertical shift is wide/narrow.

PAGE 4

• INPUT SIGNAL	• Input signal
• Y/C	• S video input signal from VIDEO IN
• RGB	• RGB input signal
• NTSC	• NTSC input signal from VIDEO IN
• PAL	• PAL input signal from VIDEO IN
• SECAM	• SECAM input signal from VIDEO IN
• B & W	• Black and white input signal from VIDEO IN
• IDTV	• IDTV input signal from the IFB-3000
• HDTV	• HDTV input signal from the IFB-1300
• COMPONENT	• Component input signal from the IFB-1200

VPH-1292QMG MODEL ONLY

List of Messages

D PAGE

Subtitle

• USER PRESET	• User preset
• USER CONTROL	• User control
• SYSTEM PRESET	• System preset
• INPUT INFO (INPUT INFORMATION)	• Input information

PAGE 1

• STATUS ON/OFF	• On-screen display on/off
• PIC MUTING ON/OFF	• Picture muting mode on/off

PAGE 2

• CONTR (CONTRAST)	• Contrast
• COLOR	• Color
• BRT (BRIGHTNESS)	• Brightness
• SHARP (SHARPNESS)	• Sharpness
• HUE	• Hue
• PIC CONTROL data reset	• Resets the PIC CONTROL data.

PAGE 3

• COLOR TEMPERATURE: 9300/6500/5400/3200	• Color temperature is set to 9300/6500/5400/3200 manually adjusted by Qualified Sony Service Personnel.
• CLAMP: AUTO / S on G / H/C / H.P	• Clamp position is set to automatic/internal/external sync signal/horizontal deflection pulse position.
• V-SHIFT: WIDE/NARROW	• The adjustable range of vertical shift is wide/narrow.

PAGE 4

• INPUT SIGNAL	• Input signal
• Y/C	• S video input signal from the IFB-1000
• RGB	• RGB input signal
• NTSC	• NTSC input signal from the IFB-1000
• PAL	• PAL input signal from the IFB-1000
• SECAM	• SECAM input signal from the IFB-1000
• B & W	• Black and white input signal from the IFB-1000
• IDTV	• IDTV input signal from the IFB-3000
• HDTV	• HDTV input signal from the IFB-1300
• COMPONENT	• Component input signal from the IFB-1200

• KEY (KEYSTONE) ADJ	• Keystone adjustment mode
• PIN (PINCUSHION) ADJ	• Pincushion adjustment mode
• ZONE ADJ	• Zone adjustment mode
• BLKG ADJ UPPER/LOWER/LEFT/RIGHT	• Blanking adjustment (upper, lower, left, or right) mode
• BIAS ADJ	• White balance bias adjustment mode
• GAIN ADJ	• White balance gain adjustment mode
• MG FOCUS ADJ	• Magnetic focus adjustment mode
• ADJ AQP/DQP	• AQP/DQP adjustment mode

9 Adjustment data

• H: xxx	• Horizontal adjustment level (xxx = MIN, 1, 2, ... 254, 255, MAX)
• V: xxx	• Vertical adjustment level (xxx = MIN, 1, 2, ... 254, 255, MAX)
• Hf: xxx	• Centering adjustment level for horizontal direction (xxx = MIN, 1, 2, ... 254, 255, MAX) Use the arrow keys to increment or decrement this number.
• Hc: xxx	• Centering adjustment level for horizontal direction (xxx = MIN, 1, 2, ... 254, 255, MAX) Use the arrow keys to increment or decrement this number.
• Vf: xxx	• Centering adjustment level for vertical direction (xxx = MIN, 1, 2, ... 254, 255, MAX) Use the arrow keys to increment or decrement this number.
• Vc: xxx	• Centering adjustment level for vertical direction (xxx = MIN, 1, 2, ... 254, 255, MAX) Use the arrow keys to increment or decrement this number.
• A: xxx	• General settings of magnetic focus adjustment level (xxx = MIN, 1, 2, ... 254, 255, MAX) Use the arrow keys to increment or decrement this number.
• VP: xxx	• Magnetic focus adjustment level for the vertical phase (V-phase) (xxx = MIN, 1, 2, ... 254, 255, MAX) Use the arrow keys to increment or decrement this number.
• HP: xxx	• Magnetic focus adjustment level for the horizontal phase (H-phase) (xxx = MIN, 1, 2, ... 254, 255, MAX) Use the arrow keys to increment or decrement this number.
• A: xxx	• AQP adjustment level (xxx = MIN, 1, 2, ... 254, 255, MAX) Use the arrow keys to increment or decrement this number.
• D: xxx	• DQP adjustment level (xxx = MIN, 1, 2, ... 254, 255, MAX) Use the arrow keys to increment or decrement this number.

List of Messages

Others

• For optimum performance, white screen will remain for 20 min. For immediate use, push [PAGE] key.	• For optimum performance, white screen will remain for 20 min. For immediate use, press the PAGE key.
• INITIALIZATION TIME SETTING	• Initialization time setting mode
• You can change the white screen display time.	• You can change the white screen display time. Standard 20 min ... xx min.
• Do you wish to enter into the SERVICEMAN CONTROL MODE?	• Do you wish to enter into the service personnel control mode?
• Do you wish to return to the USER CONTROL MODE?	• Do you wish to return to the user control mode?
• PROTECT MODE ON! You cannot enter into the SERVICEMAN CONTROL MODE.	• You cannot enter the serviceman control mode because the remote control is protected.

About error codes

When a critical operational error occurs, the power will be automatically turned off and the error code will light up on the error code window inside the front cover. You can check the code without removing the cover. Refer to the chart below for the meanings.

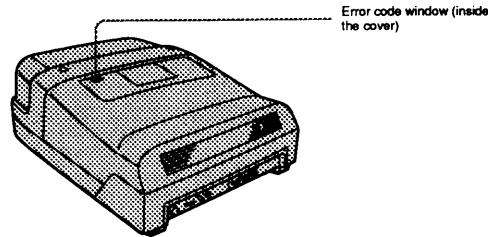

Y: Error occurrence

Error Code	FAN stop	(H stop) 115V down	IK-over	V-stop	HV-over	Power down
01.....	Y	-	-	-	-	-
02.....	-	Y	-	-	-	-
03.....	Y	Y	-	-	-	-
04.....	-	-	Y	-	-	-
05.....	Y	-	Y	-	-	-
06.....	-	Y	Y	-	-	-
07.....	Y	Y	Y	-	-	-
08.....	-	-	-	Y	-	-
09.....	Y	-	-	Y	-	-
0A.....	-	Y	-	Y	-	-
0b.....	Y	Y	-	Y	-	-
0C.....	-	-	Y	Y	-	-
0d.....	Y	-	Y	Y	-	-
0E.....	-	Y	Y	Y	-	-
0.....	Y	Y	Y	Y	-	-
10.....	-	-	-	-	Y	-
11.....	Y	-	-	-	Y	-
12.....	-	Y	-	-	Y	-
13.....	Y	Y	-	-	Y	-
14.....	-	-	Y	-	Y	-
15.....	Y	-	Y	-	Y	-
16.....	-	Y	Y	-	Y	-
17.....	Y	Y	Y	-	Y	-
18.....	-	-	-	Y	Y	-
19.....	Y	-	-	Y	Y	-

Error Code	FAN stop	(H stop) 115V down	IK-over	V-stop	HV-over	Power down
1A.....	-	Y	-	Y	Y	-
1b.....	Y	Y	-	Y	Y	-
1C.....	-	-	Y	Y	Y	-
1d.....	Y	-	Y	Y	Y	-
1E.....	-	Y	Y	Y	Y	-
1.....	Y	Y	Y	Y	Y	-
20.....	-	-	-	-	Y	-

Notes

- When the error code lights up, all the previous adjustment data will be cleared.
- The error code disappears when the MAIN POWER switch is turned off and the power cord is disconnected.
- The error code lights up every time the power is turned on until the critical operational error cause is returned to normal.

List of the Projection Distance by Angle of Optical Axis

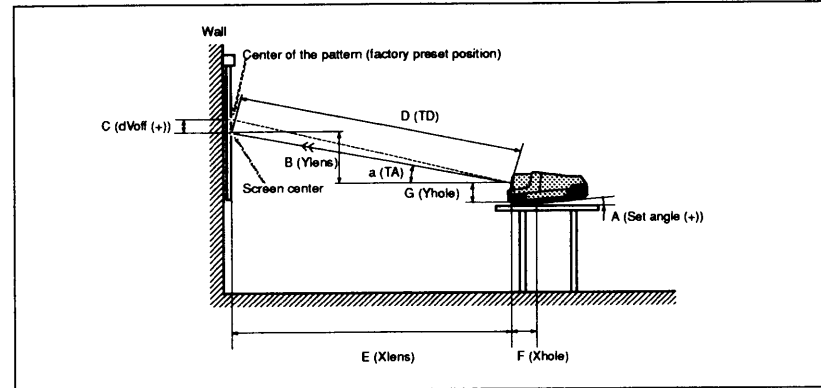

Unit: mm (inches) for F Xhole and G Yhole only

a TA (deg)	13.6°	12°	11°	10°	9°	8°	7°	6°	5°	4°	3°	2°	1°	0°	-1°	-2°
B / E	0.2419	0.2126	0.1944	0.1763	0.1584	0.1405	0.1228	0.1051	0.0875	0.0699	0.0524	0.0349	0.0175	0.0000	-0.0175	-0.0349
A Angle	0.0°	1.6°	2.6°	3.6°	4.5°	5.4°	6.4°	7.3°	8.2°	9.1°	10.0°	10.9°	11.9°	12.8°	13.7°	14.6°
F Xhole	247.4	254.5	258.9	263.2	267.3	271.1	274.9	278.6	282.2	285.8	289.2	292.6	296.0	299.2	302.4	305.5
	(9 3/4)	(10 1/4)	(10 1/2)	(10 3/4)	(10 3/4)	(10 7/8)	(10 7/8)	(11)	(11 1/8)	(11 1/4)	(11 1/4)	(11 1/2)	(11 1/2)	(11 3/4)	(12)	(12 1/2)
G Yhole	262.0	255.1	250.7	246.1	241.7	237.4	233.0	228.5	224.1	219.5	214.9	210.3	205.6	200.8	196.0	191.1
	(10 3/8)	(10 1/8)	(9 7/8)	(9 3/4)	(9 3/4)	(9 1/4)	(9 1/4)	(9)	(8 7/8)	(8 3/4)	(8 3/4)	(8 1/4)	(8 1/4)	(8)	(7 3/4)	(7 3/8)

When using the 90 inch screen

Unit: mm (inches)

a TA (deg)	13.6°	12°	11°	10°	9°	8°	7°	6°	5°	4°	3°	2°	1°	0°	-1°	-2°
E Xlens	2515	2529	2536	2543	2549	2554	2558	2562	2565	2567	2569	2570	2570	2570	2569	2568
	(99 1/4)	(99 1/4)	(99 1/4)	(100 1/4)	(100 1/4)	(100 1/4)	(100 1/4)	(100 1/4)	(101)	(101 1/4)	(101 1/4)	(101 1/4)	(101 1/4)	(101 1/4)	(101 1/4)	(101 1/4)
B Ylens	606	538	493	448	404	359	314	269	224	180	135	90	45	0	-45	-90
	(23 3/4)	(21 1/4)	(19 1/2)	(17 3/4)	(16)	(14 1/4)	(12 3/4)	(10 3/4)	(8 7/8)	(7 1/4)	(5 3/4)	(3 3/4)	(1 3/4)	(0)	(-1 3/4)	(-3 3/4)
D TD	2587	2585	2584	2582	2581	2579	2577	2576	2575	2574	2573	2572	2571	2570	2570	2569
	(101 1/4)	(101 1/4)	(101 1/4)	(101 1/4)	(101 1/4)	(101 1/4)	(101 1/4)	(101 1/4)	(101 1/4)	(101 1/4)	(101 1/4)	(101 1/4)	(101 1/4)	(101 1/4)	(101 1/4)	(101 1/4)
C dVoff	0	0	0	0	3	7	10	14	17	21	24	28	32	35	39	42
	(0)	(0)	(0)	(0)	(1/4)	(3/8)	(1/2)	(5/8)	(3/4)	(7/8)	(1)	(1 1/4)	(1 1/2)	(1 3/4)	(1 3/4)	(1 7/8)
Spacer																
Red-L	-10	-9	-8	-7	-6	-5	-4	-2.5	-1	0	1	2	2.5	2.5	3	3
Red-C	15.5	15	15.5	16	16.5	17.5	-17.5	-16	-14.5	-13.5	-12.5	-11.5	-10.5	-9.5	-9	-9
Green-L	-12.5	-11.5	-11	-10.5	-10.5	-10	-9.5	-9.5	-9	-8.5	-8	-8	-7.5	-7	-6.5	-6.5
Green-C	12.5	11.5	11	10.5	10.5	10	9.5	9.5	9	8.5	8	8	7.5	7	6.5	6.5
Blue-L	10	9	8	7	6	5	4	2.5	1	0	-1	-2	-2.5	-2.5	-3	-3
Blue-C	-15.5	-15	-15	-15.5	-16	-16.5	-17.5	17.5	16	14.5	13.5	12.5	11.5	10.5	9.5	9

When using the 140 inch screen

Unit: mm (Inches)

Table with columns: a TA (deg), 13.6°, 12°, 11°, 10°, 9°, 8°, 7°, 6°, 5°, 4°, 3°, 2°, 1°, 0°, -1°, -2°. Rows include Xlens, Ylens, TD, dVoff, and Spacer (Red-L, Red-C, Green-L, Green-C, Blue-L, Blue-C).

When using the 150 inch screen

Unit: mm (Inches)

Table with columns: a TA (deg), 13.6°, 12°, 11°, 10°, 9°, 8°, 7°, 6°, 5°, 4°, 3°, 2°, 1°, 0°, -1°, -2°. Rows include Xlens, Ylens, TD, dVoff, and Spacer (Red-L, Red-C, Green-L, Green-C, Blue-L, Blue-C).

List of the Projection Distance by Angle of Optical Axis

When using the 160 inch screen

Unit: mm (Inches)

Table with columns: a TA (deg), 13.6°, 12°, 11°, 10°, 9°, 8°, 7°, 6°, 5°, 4°, 3°, 2°, 1°, 0°, -1°, -2°. Rows include Xlens, Ylens, TD, dVoff, and Spacer (Red-L, Red-C, Green-L, Green-C, Blue-L, Blue-C).

When using the 170 inch screen

Unit: mm (Inches)

Table with columns: a TA (deg), 13.6°, 12°, 11°, 10°, 9°, 8°, 7°, 6°, 5°, 4°, 3°, 2°, 1°, 0°, -1°, -2°. Rows include Xlens, Ylens, TD, dVoff, and Spacer (Red-L, Red-C, Green-L, Green-C, Blue-L, Blue-C).

When using the 180 inch screen

Unit: mm (inches)

a TA (deg)	13.6°	12°	11°	10°	9°	8°	7°	6°	5°	4°	3°	2°	1°	0°	-1°	-2°
E)Xiens	4993	5020	5035	5049	5060	5070	5079	5086	5092	5097	5100	5102	5103	5102	5100	5097
B)Ylens	1205	1067	979	890	802	713	624	535	446	356	267	178	89	0	-89	-178
D)TD	5137	5132	5130	5127	5123	5120	5117	5114	5112	5109	5107	5105	5104	5102	5101	5100
C)dVoff	0	0	0	0	6	13	20	27	34	41	48	55	62	69	76	84
Spacer																
Red-L	-7.5	-5.5	-4	-1.5	1.5	3.5	4.5	5.5	5.5	6	6	6	6	6	6	6
Red-C	12.5	13.5	15	17.5	-16	-13.5	-12	-11	-10.5	-10	-9.5	-9	-9	-8.5	-8	-8
Green-L	-10	-9.5	-9.5	-9	-9	-8.5	-8.5	-8.5	-8	-8	-8	-7.5	-7.5	-7.5	-7	-7
Green-C	10	9.5	9.5	9	9	8.5	8.5	8.5	8	8	8	7.5	7.5	7.5	7	7
Blue-L	7.5	5.5	4	1.5	-1.5	-3.5	-4.5	-5.5	-5.5	-6	-6	-6	-6	-6	-6	-6
Blue-C	-12.5	-13.5	-15	-17.5	16	13.5	12	11	10.5	10	9.5	9	9	8.5	8	8

When using the 190 inch screen

Unit: mm (inches)

a TA (deg)	13.6°	12°	11°	10°	9°	8°	7°	6°	5°	4°	3°	2°	1°	0°	-1°	-2°
E)Xiens	5268	5297	5313	5327	5339	5349	5359	5366	5372	5377	5381	5383	5384	5383	5381	5378
B)Ylens	1272	1126	1033	939	846	752	658	564	470	376	282	188	94	0	-94	-188
D)TD	5419	5415	5412	5409	5406	5402	5399	5396	5393	5390	5388	5386	5385	5383	5382	5381
C)dVoff	0	0	0	0	6	14	21	28	36	43	51	58	65	73	81	88
Spacer																
Red-L	-7	-5	-3	0	2.5	4.5	5	5.5	6	6	6	6	6	6	6	6
Red-C	12.5	14	15.5	-17.5	-14.5	-12.5	-11.5	-10.5	-10	-9.5	-9.5	-9	-8.5	-8.5	-8	-8
Green-L	-9.5	-9.5	-9	-9	-9	-8.5	-8.5	-8.5	-8	-8	-8	-7.5	-7.5	-7.5	-7	-7
Green-C	9.5	9.5	9	9	9	8.5	8.5	8.5	8	8	8	7.5	7.5	7.5	7	7
Blue-L	7	5	3	0	-2.5	-4.5	-5	-5.5	-6	-6	-6	-6	-6	-6	-6	-6
Blue-C	-12.5	-14	-15.5	17.5	14.5	12.5	11.5	10.5	10	9.5	9.5	9	8.5	8.5	8	8

List of the Projection Distance by Angle of Optical Axis

When using the 200 inch screen

Unit: mm (inches)

a TA (deg)	13.6°	12°	11°	10°	9°	8°	7°	6°	5°	4°	3°	2°	1°	0°	-1°	-2°
E)Xiens	5543	5573	5590	5605	5618	5629	5638	5646	5653	5658	5662	5664	5665	5664	5662	5658
B)Ylens	1338	1185	1087	988	890	791	692	593	496	396	297	198	99	0	-99	-198
D)TD	5702	5697	5694	5691	5688	5684	5680	5677	5674	5672	5669	5667	5665	5664	5663	5662
C)dVoff	0	0	0	0	7	14	22	30	38	45	53	61	69	77	85	93
Spacer																
Red-L	-7	-4.5	-2	1.5	4	5	5.5	6	6.5	6.5	6.5	6.5	6.5	6.5	6	6
Red-C	12.5	14	17	-16	-13.5	-12	-11	-10.5	-10	-9.5	-9	-9	-8.5	-8.5	-8	-8
Green-L	-9.5	-9.5	-9	-9	-8.5	-8.5	-8.5	-8	-8	-8	-7.5	-7.5	-7.5	-7	-7	-7
Green-C	9.5	9.5	9	9	8.5	8.5	8.5	8	8	8	7.5	7.5	7.5	7	7	7
Blue-L	7	4.5	2	-1.5	-4	-5	-5.5	-6	-6.5	-6.5	-6.5	-6.5	-6.5	-6.5	-6	-6
Blue-C	-12.5	-14	-17	16	13	12	11	10.5	10	9.5	9	9	8.5	8.5	8	8

When using the 210 inch screen

Unit: mm (inches)

a TA (deg)	13.6°	12°	11°	10°	9°	8°	7°	6°	5°	4°	3°	2°	1°	0°	-1°	-2°
E)Xiens	5816	5847	5865	5881	5894	5906	5916	5924	5931	5937	5941	5943	5944	5943	5941	5937
B)Ylens	1404	1243	1140	1037	934	830	726	623	519	415	311	208	104	0	-104	-208
D)TD	5983	5978	5975	5972	5968	5964	5960	5957	5954	5951	5949	5947	5945	5943	5942	5941
C)dVoff	0	0	0	0	7	15	23	31	39	47	56	64	72	81	89	97
Spacer																
Red-L	-6.5	-3.5	-0.5	3	4.5	5.5	6	6.5	6.5	6.5	6.5	6.5	6.5	6.5	6.5	6
Red-C	12.5	15	-18	-14.5	-12.5	-11.5	-10.5	-10	-9.5	-9.5	-9	-8.5	-8.5	-8	-8	-7.5
Green-L	-9.5	-9	-9	-9	-8.5	-8.5	-8.5	-8	-8	-8	-7.5	-7.5	-7.5	-7	-7	-7
Green-C	9.5	9	9	9	8.5	8.5	8.5	8	8	8	7.5	7.5	7.5	7	7	7
Blue-L	6.5	3.5	0.5	-3	-4.5	-5.5	-6	-6.5	-6.5	-6.5	-6.5	-6.5	-6.5	-6.5	-6.5	-6
Blue-C	-12.5	-15	-18	14.5	12.5	11.5	10.5	10	9.5	9.5	9	8.5	8.5	8	8	7.5

When using the 220 inch screen

Unit: mm (Inches)

Table with columns for TA (deg) from 13.6° to -2° and rows for E Xlens, B Ylens, D TD, C dVoff, and Spacer (Red-L, Red-C, Green-L, Green-C, Blue-L, Blue-C).

When using the 230 inch screen

Unit: mm (Inches)

Table with columns for TA (deg) from 13.6° to -2° and rows for E Xlens, B Ylens, D TD, C dVoff, and Spacer (Red-L, Red-C, Green-L, Green-C, Blue-L, Blue-C).

List of the Projection Distance by Angle of Optical Axis

When using the 240 inch screen

Unit: mm (Inches)

Table with columns for TA (deg) from 13.6° to -2° and rows for E Xlens, B Ylens, D TD, C dVoff, and Spacer (Red-L, Red-C, Green-L, Green-C, Blue-L, Blue-C).

When using the 250 inch screen

Unit: mm (Inches)

Table with columns for TA (deg) from 13.6° to -2° and rows for E Xlens, B Ylens, D TD, C dVoff, and Spacer (Red-L, Red-C, Green-L, Green-C, Blue-L, Blue-C).

When using the 260 inch screen

Unit: mm (Inches)

Table with columns for TA (deg) and rows for Xlens, Ylens, TD, dVoff, and Spacer. Values range from -16.5 to 7.5.

When using the 270 inch screen

Unit: mm (Inches)

Table with columns for TA (deg) and rows for Xlens, Ylens, TD, dVoff, and Spacer. Values range from -18 to 7.5.

List of the Projection Distance by Angle of Optical Axis

When using the 280 inch screen

Unit: mm (Inches)

Table with columns for TA (deg) and rows for Xlens, Ylens, TD, dVoff, and Spacer. Values range from -16 to 7.5.

When using the 290 inch screen

Unit: mm (Inches)

Table with columns for TA (deg) and rows for Xlens, Ylens, TD, dVoff, and Spacer. Values range from -14.5 to 7.5.

When using the 300 inch screen

Unit: mm (inches)

a TA (deg)	13.6°	12°	11°	10°	9°	8°	7°	6°	5°	4°	3°	2°	1°	0°	-1°	-2°		
E Xtens	8295 (326 1/4)	8340 (328 1/4)	8365 (329 1/4)	8388 (330 1/4)	8406 (331)	8423 (331 1/4)	8437 (332 1/4)	8449 (332 1/4)	8459 (333 1/4)	8467 (333 1/4)	8472 (333 1/4)	8476 (333 1/4)	8477 (333 1/4)	8476 (333 1/4)	8473 (333 1/4)	8467 (333 1/4)		
B Ytens	2004 (79)	1773 (69 1/4)	1626 (64 1/4)	1479 (58 1/4)	1331 (52 1/2)	1184 (46 1/4)	1036 (40 1/4)	888 (35)	740 (29 1/4)	592 (23 1/4)	444 (17 1/2)	296 (11 1/4)	148 (5 7/8)	0 (0)	-148 (-5 7/8)	-296 (-11 1/4)		
D TD	8533 (336)	8526 (335 1/4)	8522 (335 1/4)	8517 (335 1/4)	8511 (335 1/4)	8506 (334 1/4)	8501 (334 1/4)	8496 (334 1/4)	8491 (334 1/4)	8488 (334 1/4)	8484 (334 1/4)	8481 (334)	8478 (330 1/4)	8476 (333 1/4)	8474 (330 1/4)	8472 (333 1/4)		
C dVoff	0 (0)	0 (0)	0 (0)	0 (0)	11 (7/4)	22 (7/4)	34 (1 1/4)	45 (1 13/4)	57 (2 1/4)	69 (2 3/4)	80 (3 1/4)	92 (3 3/4)	104 (4 1/4)	116 (4 1/4)	128 (5 1/4)	139 (5 1/4)		
Spacer																		
Red-L	4	6	6.5	6.5	7	7	7	7	7	7	7	7	7	7	6.5	6.5	6.5	
Red-C	-13.5	-11.5	-10.5	-10	-9.5	-9.5	-9	-9	-9	-8.5	-8.5	-8	-8	-8	-8	-8	-7.5	
Green-L	-9	-8.5	-8.5	-8.5	-8.5	-8	-8	-8	-8	-8	-7.5	-7.5	-7.5	-7.5	-7.5	-7	-7	
Green-C	9	8.5	8.5	8.5	8.5	8	8	8	8	8	7.5	7.5	7.5	7.5	7.5	7	7	
Blue-L	-4	-6	-6.5	-6.5	-7	-7	-7	-7	-7	-7	-7	-7	-7	-7	-7	-6.5	-6.5	-6.5
Blue-C	13.5	11.5	10.5	10	9.5	9.5	9	9	9	9	8.5	8.5	8	8	8	8	8	7.5

Index

A

- Adjusting
 - AQP/DQP 53, 55 (E)
 - black level 85 (E)
 - blanking 59 (E)
 - blue centering 75 (E)
 - blue focus 55 (E)
 - blue registration 75 (E)
 - CRT conversion angle 20 (E)
 - each input signal fine 80 (E)
 - green centering 61 (E)
 - green focus 49 (E)
 - green KEY and PIN 66 (E)
 - green registration 61 (E)
 - green SIZE and LIN 62 (E)
 - green SKEW and BOW 64 (E)
 - magnetic focus 51 (E)
 - magnetic focus fine 80 to 82 (E)
 - picture size 81 (E)
 - picture quality 92 (E)
 - red centering 68 (E)
 - red focus 55 (E)
 - red KEY and PIN 72 (E)
 - red registration 68 (E)
 - red SIZE and LIN 68 (E)
 - red SKEW and BOW 70 (E)
 - red ZONE 74 (E)
 - registration fine 80 (E), 82 (E)
 - RGB input signal 82 (E)
 - RGB SHIFT 84 (E)
 - RGB SIZE 83 (E)
 - white balance 85 (E)
 - white level 86 (E)
- AQP 53 (E)

B

- BAUD RATE PRESET (PAGE5) 44 (E)
- Blanking 60 (E)

C

- Carrying the projector 8 (E)
- Changing
 - initialization period 93 (E)
 - picture luminance (clamp setting) 87 (E)
 - polarity 22 (E)
 - ring spacers 18 (E)
 - Clamp setting 87 (E)
- COLOR TEMPERATURE: (PAGE3) 42 (E)
- Connecting
 - remote control to the projector 38 (E)
 - to external equipment directly 28 (E)
 - using the optional board or switcher 31 (E) to 33 (E)
 - when projecting the high resolution pictures 34 (E)
- CRT TIMER DISPLAY (PAGE5) 44 (E)

D

- Data reset 88 (E)
- DQP 53 (E)

E

- Error codes 101 (E)
- Error code window 101 (E)

F

- Factory preset 89 (E)

G

- Grips
 - inserting 8 (E)
 - removing 9 (E)

H

- H/C SYNC: (PAGE 4) 43 (E)

I, J, K

- INPUT SIGNAL: (PAGE 4) 43 (E)
- Inserting the grips 8 (E)
- Installation
 - ceiling installation 11 (E)
 - diagrams 5 (E)
 - floor installation for front projection 10 (E)
 - floor installation for rear projection 13 (E)
 - procedures 4 (E)
- Installing
 - batteries to the remote control 37 (E)
 - optional interface board 30 (E)

L

- List
 - messages 95 (E)
 - projection distance by optical axis angle 102 (E)
 - test patterns 46 (E)
- Location and function of connectors 27 (E)

M

- Memory
 - architecture 79 (E)
 - structure 78 (E)

N, O

- Notes on screen
 - available types of screen 16 (E)
 - screen size 15 (E)
 - with an aspect ratio other than 4:3 15 (E)

P, Q

- PAGE displays 42 (E)
- PIC MUTING (PAGE 1) 42 (E)
- Protecting the setting 91 (E)

R

- REGI BLOCK: (PAGE 4) 43 (E)
- Remote control

- battery installation 37 (E)
 - preparation 36 (E)
- Releasing the blanking 59 (E)
- Removing the grips 9 (E)

Resetting

- data 88 (E)
- standard data to the factory preset levels 89 (E)

- Ring spacers 18 (E)

S

- Saving the data
 - memory architecture 79 (E)
 - memory structure 78 (E)
 - saving the standard registration data 77 (E)
- Screen
 - available types 16 (E)
 - size 15 (E)
 - with an aspect other than 4:3 15 (E)
- Screen messages
 - color codes 45 (E)
 - error messages 45 (E)
- Setting
 - dynamic picture 25 (E)
 - white balance 85 (E)
- STATUS: (PAGE 1) 42 (E)
- SYNC ON G: (PAGE 4) 43 (E)

T

- Test patterns 46 (E)
- Turning off "OFF" indication 94 (E)

U

- Using the side handles 8 (E)

V

- V-SHIFT: (PAGE 3) 43 (E)
- V-SYNC: (PAGE 4) 43 (E)

W

- What is blanking? 60 (E)
- What is the AQP/DQP adjustment? 53 (E)
- When the screen size is not mentioned in the tables 12 (E)

SECTION 2 DISASSEMBLY

2-1. COVER REMOVAL

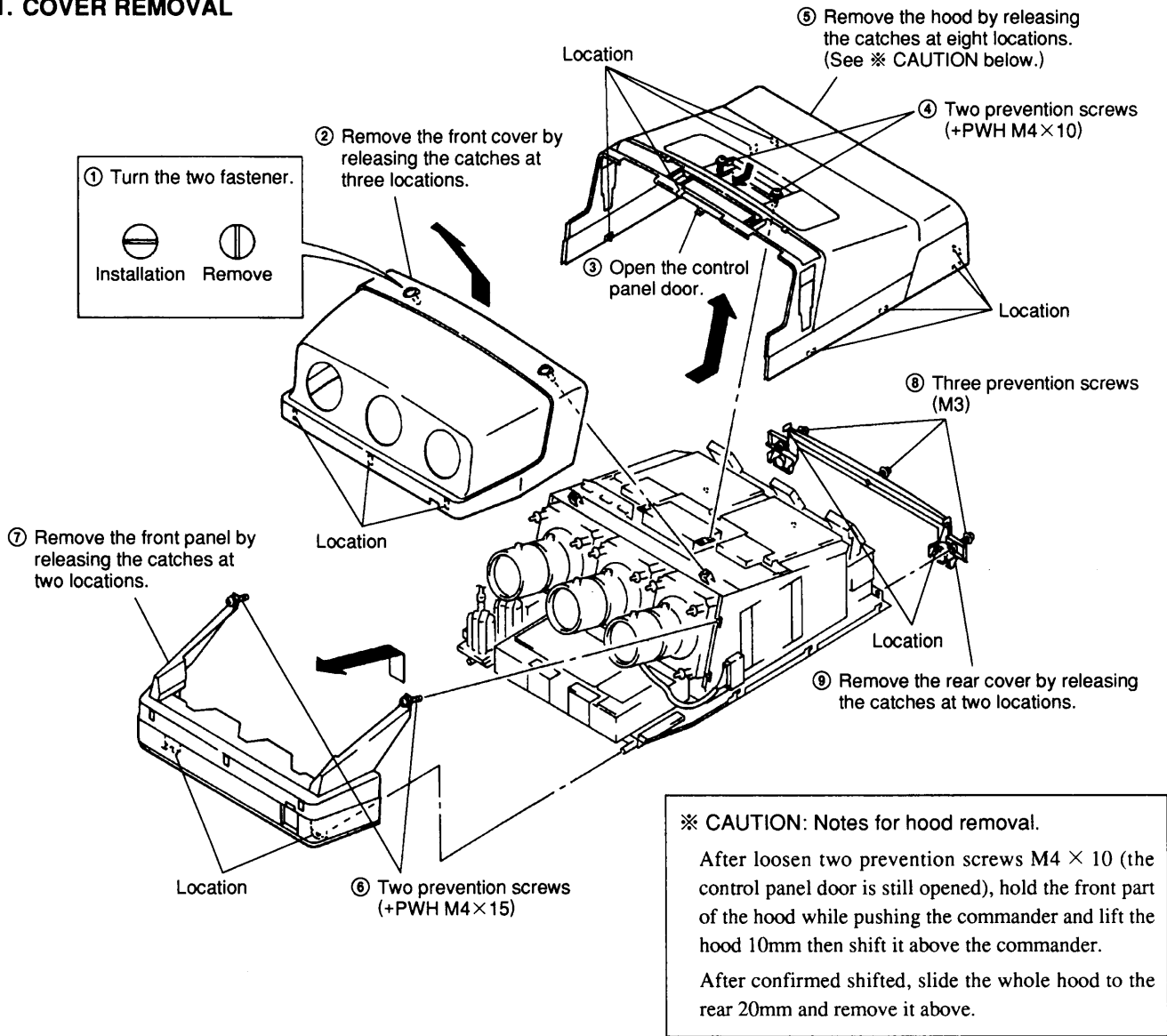

2-2. LENS REMOVAL

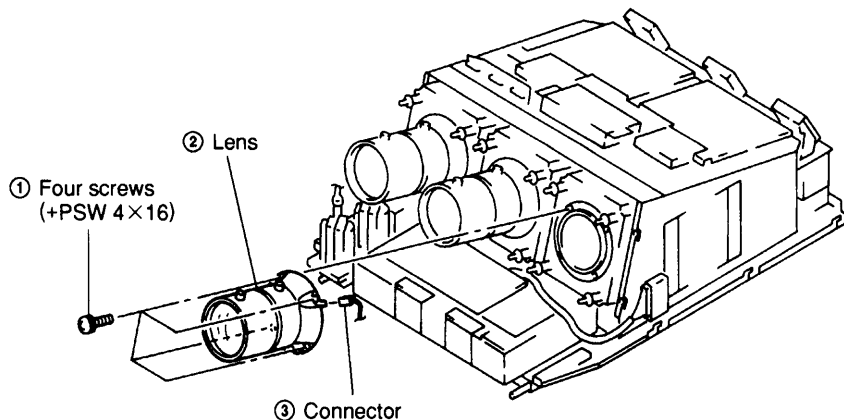

2-3. POWER BLOCK REMOVAL

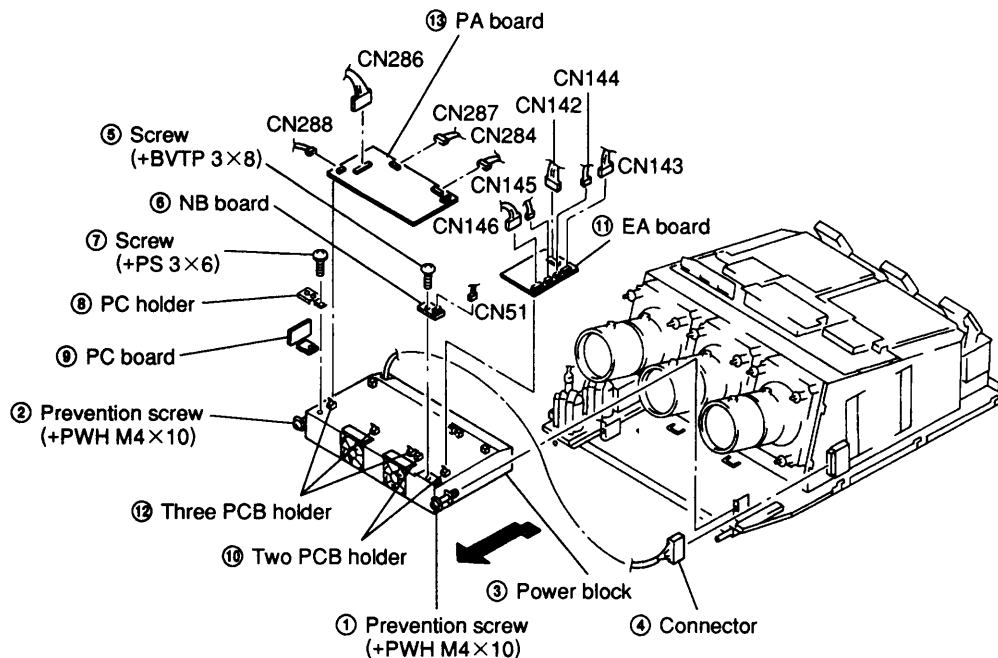

2-4. ED BLOCK REMOVAL

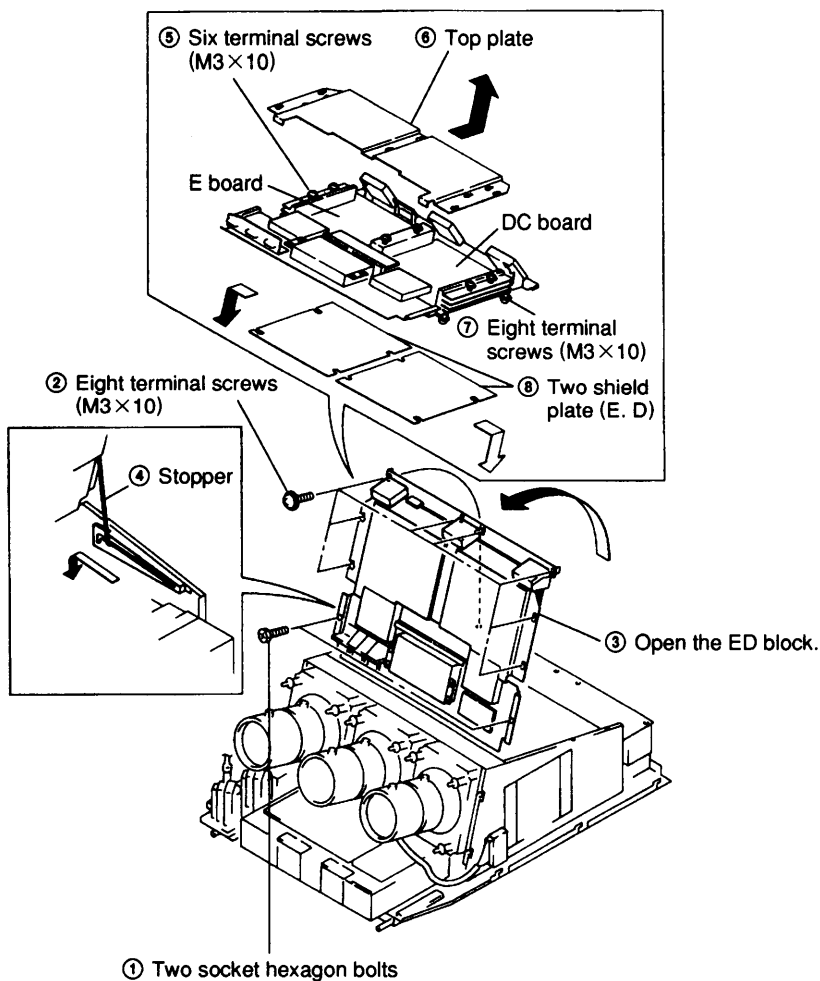

2-5. HIGH-VOLTAGE BLOCK REMOVAL

HIGH VOLTAGE CABLE REMOVAL

- ① Pressing cable, Turn 90°.
- ② Pull out a cable.

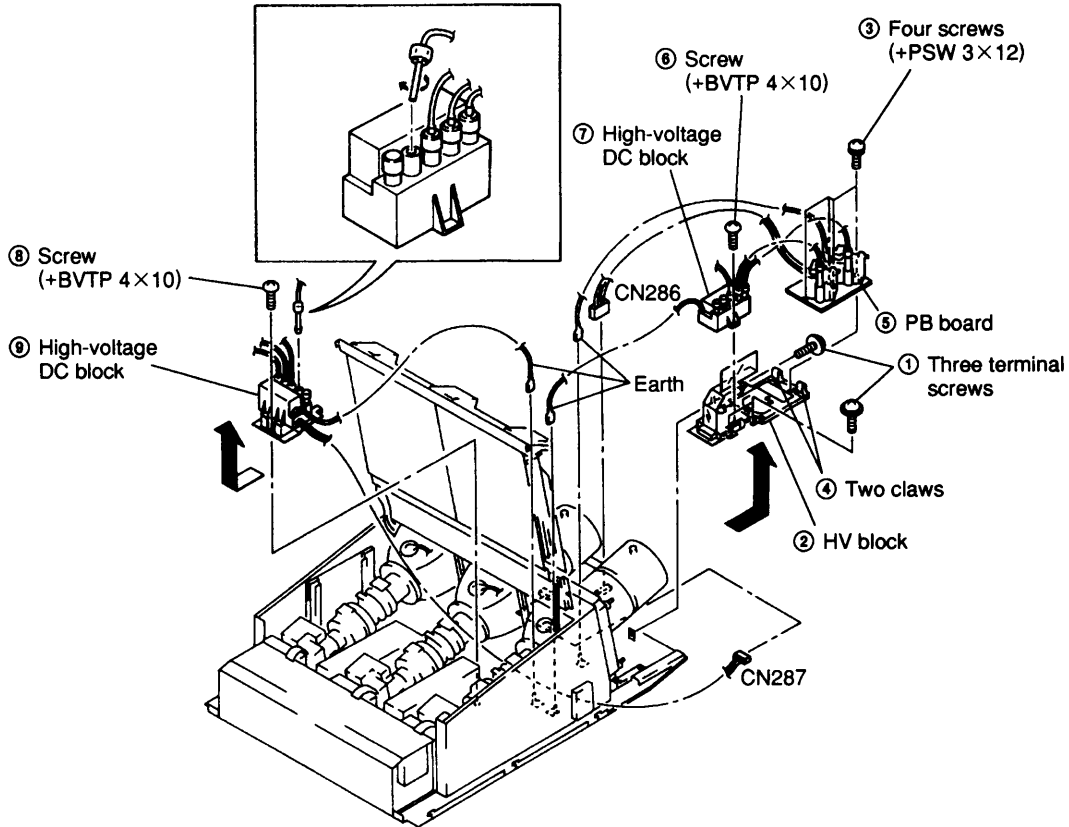

2-6. INTERFACE UNIT, BA, BB AND BC BOARDS REMOVAL

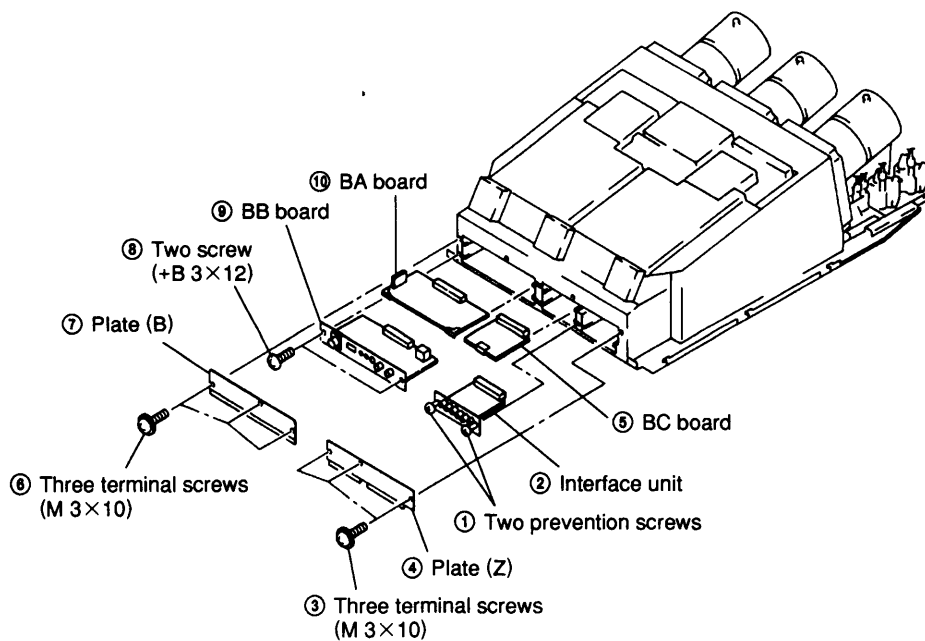

2-7. Y, DA, DB, DD AND DE BOARDS REMOVAL

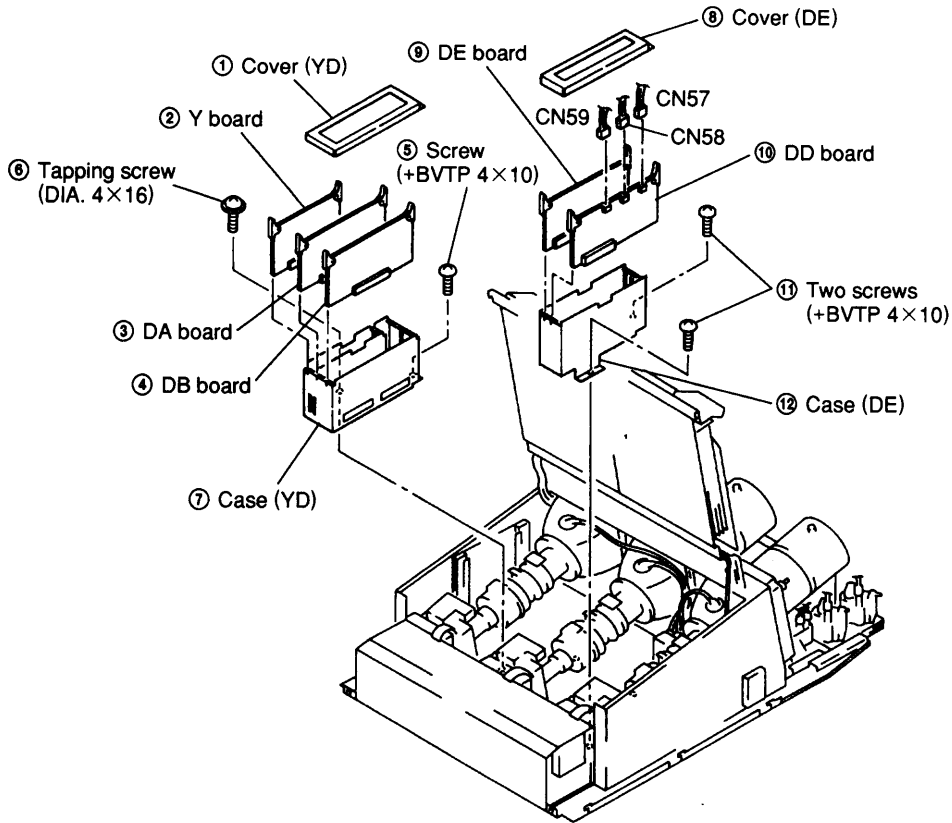

2-8. EBRG AND EBB BOARDS REMOVAL

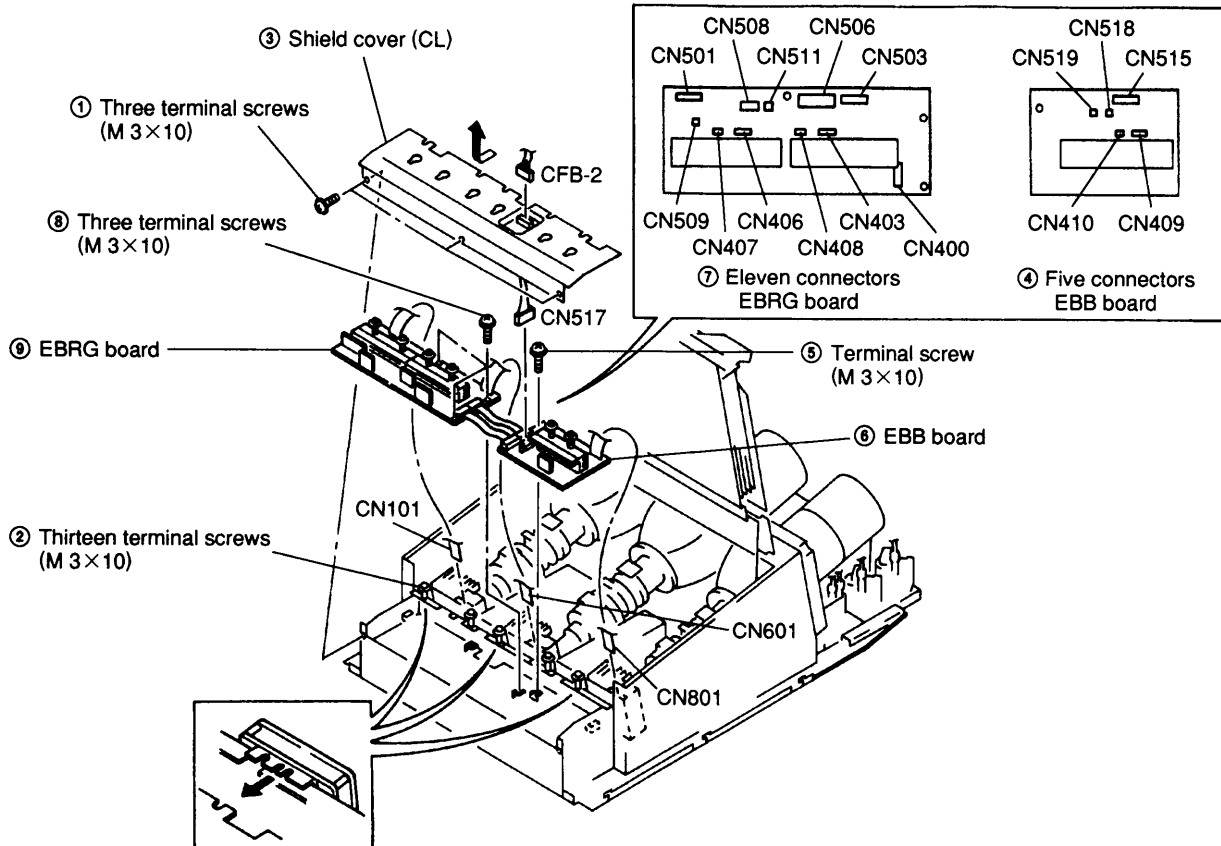

2-9. DM BOARD REMOVAL

- ① Remove the Y, DA, DB, DD and DE board.
(Refer. 2-7)
- ② Remove the EBRG and EBB board.
(Refer. 2-8)

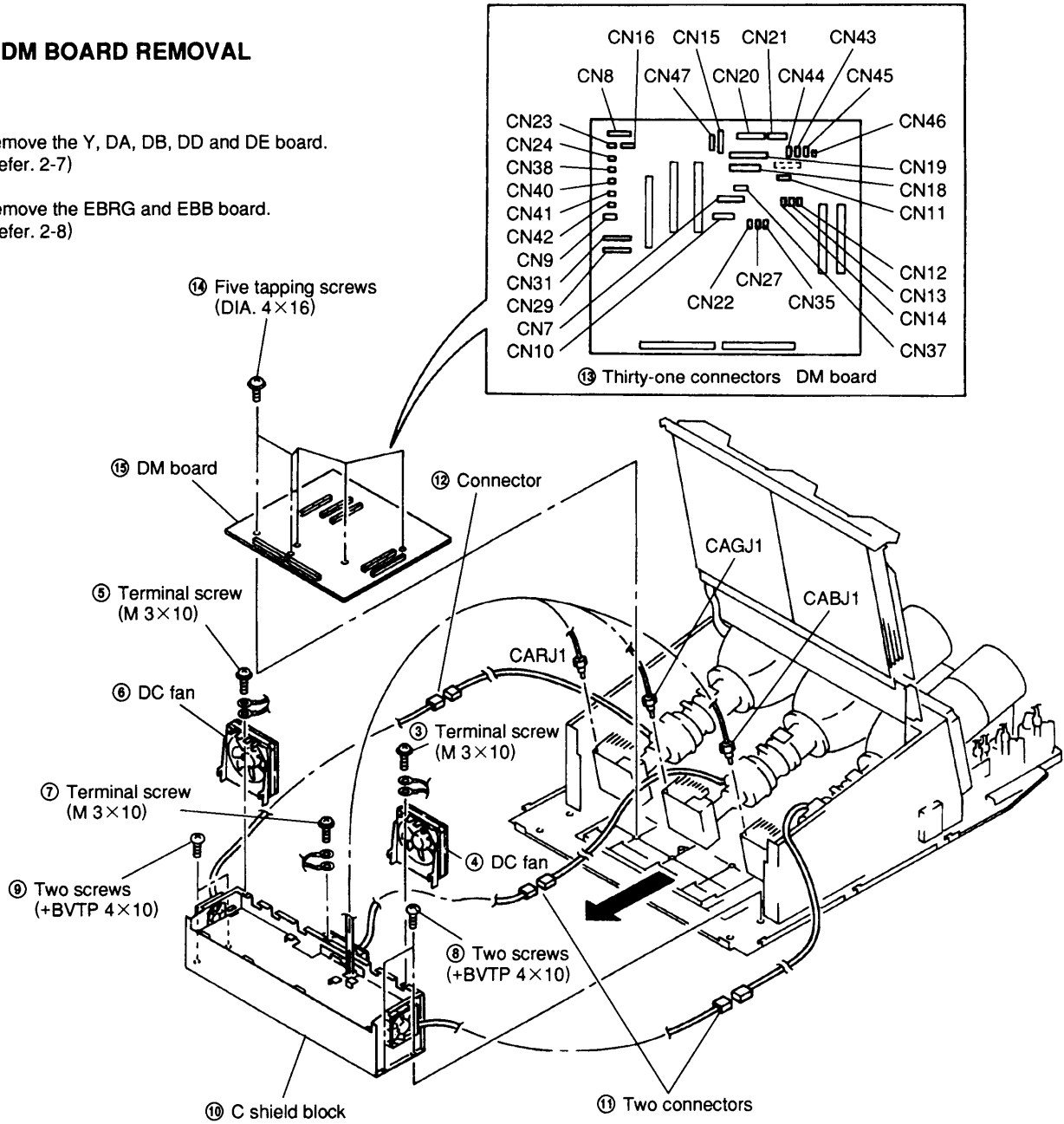

2-10. ATTACHMENT DIRECTION OF THE DC FAN

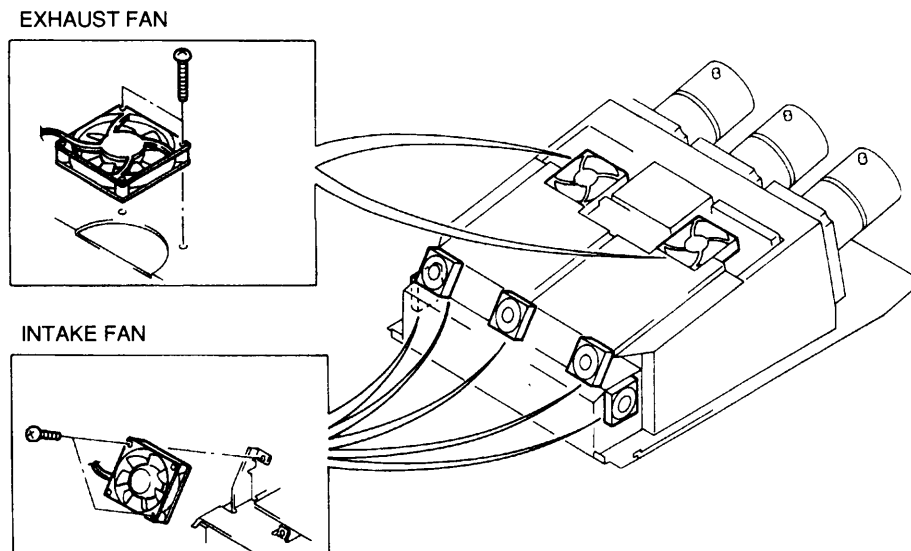

2-11. PICTURE TUBE REMOVAL

HIGH VOLTAGE CABLE REMOVAL

- ① Pressing cable, Turn 90°.
- ② Pull out a cable.

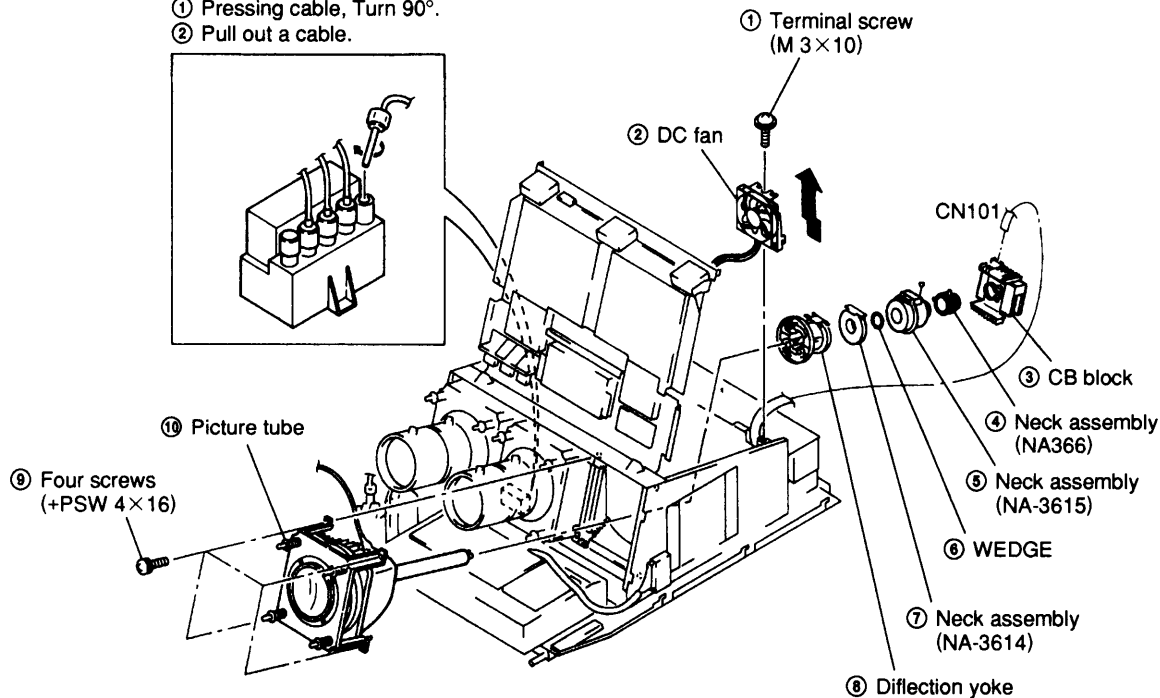

2-12. CAB AND CBB BOARDS REMOVAL

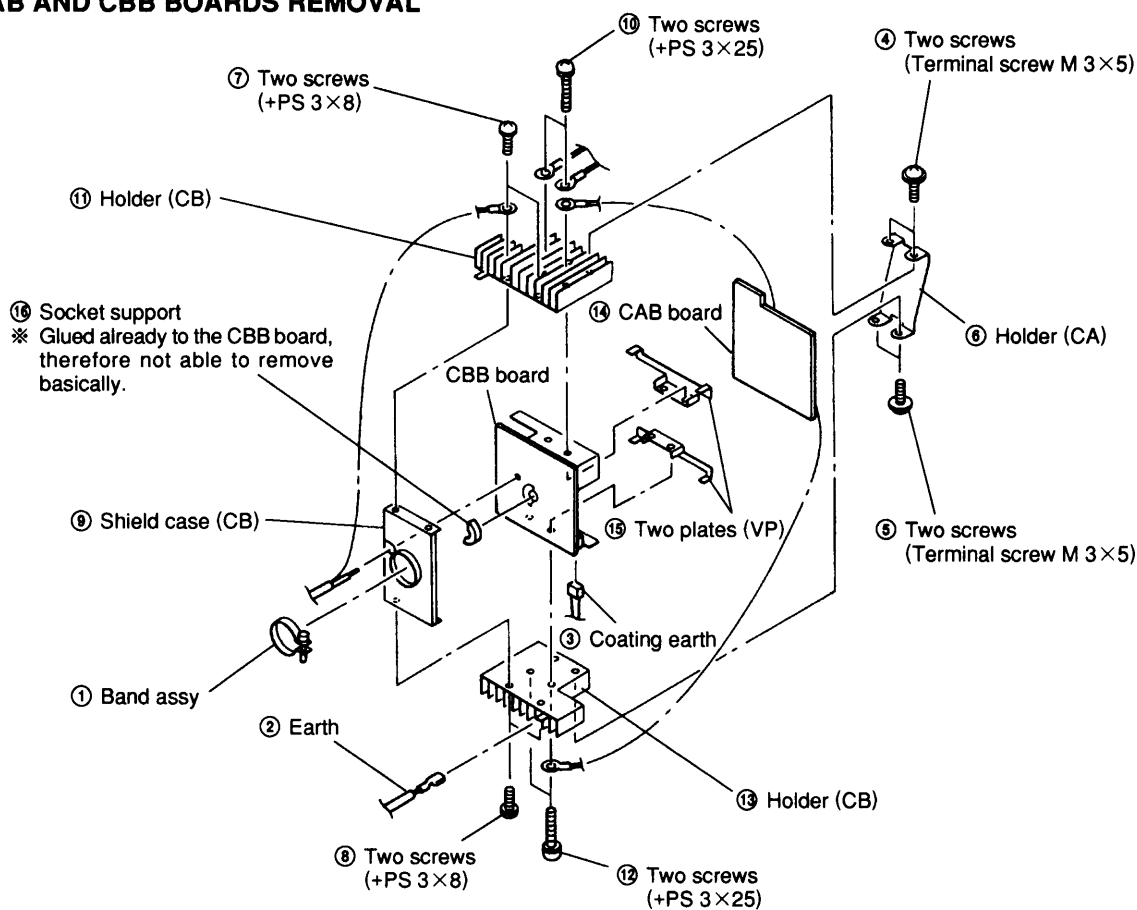

SECTION 3 SET-UP ADJUSTMENT

Note:

- When exchanging CRT, fit tightly DY to CRT, set neck assembly position and adjust.
- Service mode is released when the power is turned OFF.

3-1. NECK ASSEMBLY INSTALLATION

1. Fit DY tightly to CRT funnel first and then tightly fit Sub DY.
2. Temporary install 2-pole and 4-pole magnet assembly 6 to 8 mm away from left DY.
3. Install the CB board.

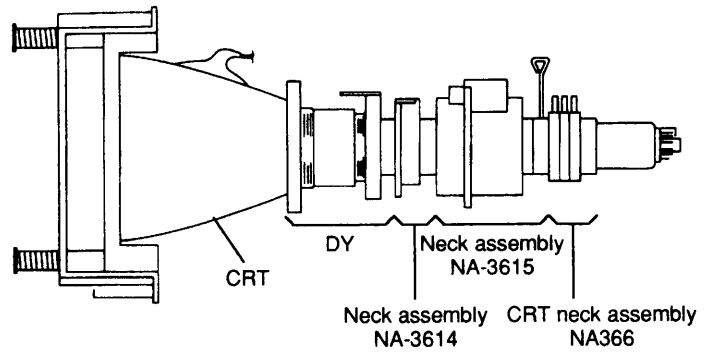

3-2. WORK CONDITION FOR ADJUSTMENT

(1) Projection System

1. Place a projector on a work bench which satisfies the projection conditions shown in Figure 1. (Refer to Figures 1-1, 1-2, 1-3.)

(2) Power Supply

1. AC power input conditions
 - For J models AC 100 V
 - For U/C models AC 120 V
 - For AEP models AC 240 V
 Frequency for the above power supplies must be 50 Hz with distortion of 3 % or less.

* When an adjustable power transformer is used, the transformer must have capacity of 1.5 kW or more.

(3) Signal

1. Use the video signal specified by Figure 2.

NTSC (3.58)	NTSC (4.43)	PAL	SECAM
Color bar	Color bar	SP color bar	Color bar
Monoscope		Color bar	
D monoscope			
Dot			
All white			

Figure 2

2. Use the VTR (VHS) having S. VIDEO output to supply the S. VIDEO signal.
3. Use the ASTRO VG-819 to which the exclusive ROM (for VPH-1292) is attached to supply the RGB signal.

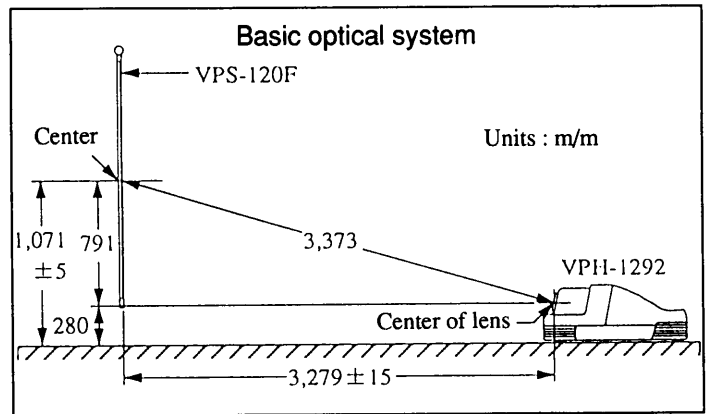

Figure 1-1

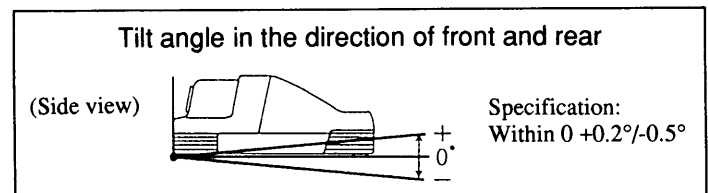

Figure 1-2

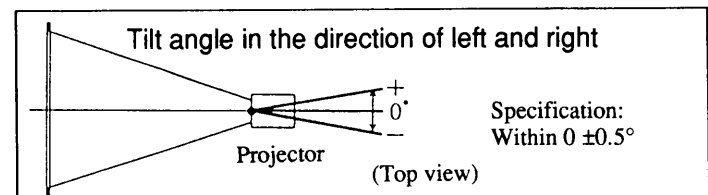

Figure 1-3

3-3. FOCUS ADJUSTMENT

3-3-1. Preparation

1. Connect the video signal to the VIDEO-IN connector, the RGB signal cable to the RGB input connector of SLOT-A terminal and the remote control cable to the CONTROL-S connector respectively.
2. Adjust RV104 on the E board for about 50 %.
3. Press the POWER ON key to turn on the main power to the projector.
4. Open the ED bracket and set the switch No. 1 of the SW-1 on the Y board to OFF (bottom) position.
5. Press the SW-2 (push switch) to reset all the data.

* When the switch is pressed, the LED on the Y board flashes momentarily.

3-3-2. Focus Rough Adjustment

1. Press the INPUT-B key to disconnect all input signals.
2. Press the BLK key and confirm that the projector enters the blanking adjustment mode, and the message appears as shown in Figure 3.

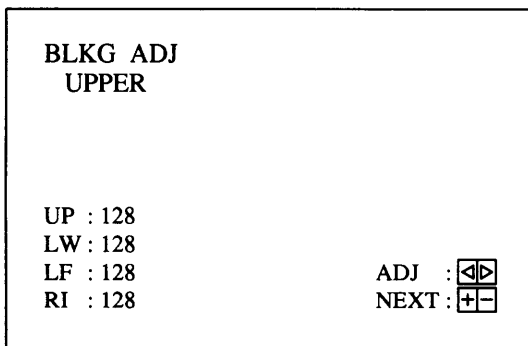

Figure 3

3. Keep pressing the ▲ key of the arrow keys and confirm that the UP data on the message display changes linearly from 128 to MAX while synchronizing with the blanking on top of the display moved outside the screen.
4. Press the (+) key of the POSITION keys to enter the lower blanking adjustment mode.
5. Keep pressing the ▼ key of the arrow keys and confirm that the LW data on the message display changes linearly from 128 to MIN while synchronizing with the lower blanking moved outside the screen.
6. Press the (+) key of the POSITION keys to enter the left blanking adjustment mode.

7. Keep pressing the ◀ key of the arrow keys and confirm that the LF data on the message display changes linearly from 128 to MIN while synchronizing with the left blanking moved outside the screen.
8. Press the (+) key of the POSITION keys to enter the right blanking adjustment mode.
9. Keep pressing the ▶ key of the arrow keys and confirm that the RI data on the message display changes linearly from 128 to MAX while synchronizing with the right blanking moved outside the screen.
10. Press the MEMORY key to store the blanking data.
11. Press the NORMAL key to clear the BLK character display.
12. Close the ED bracket.
13. Press the TEST key to show the internal cross-hatched signal.
14. Adjust the main lens focus controls of the R. G. B. channels respectively to adjust roughly their center focus. Adjust the sub lens focus controls of the R. G. B. channels respectively to adjust roughly their corner focus.

3-3-3. Centering and Size Preliminary Adjustments

1. Press the VIDEO key to select the monoscope input signal to show on the screen.
2. Press the R key and the B key of the CENT keys simultaneously to enter the green channel centering adjustment.
3. Use the ◀, ▶, ▲, ▼ keys of the arrow keys until the vertical line and the horizontal line of the cross-hair come to the center of screen.
4. Press the R key of the CENT keys to select the red channel and adjust the red channel centering in the same way.
5. Press the B key of the CENT keys to select the blue channel and adjust the blue channel centering in the same way.
6. Press the SIZE key of the REGISTRATION and press the ADJ. G key.
7. Use the ◀ and ▶ keys of the arrow keys until both ends of the cross-hair extend to the full size of the screen.
8. Press the MEMORY key.

3-3-4. Angle Adjustment of DY, Sub DY and Mg Focus

1. Press the INPUT B key to disconnect all input signals.
2. Press the R key and B key of the CENT keys to enter the green channel centering adjustment mode.
3. Open the ED bracket and rotate the red DY to the left about 30° and the blue DY to about to the right about 30°.
4. Adjust roughly tilt of R, G, and B channels so that their sub DY and Mg focus connectors come to the top.

5. Adjust angle of the green DY until the horizontal line of the cross hair is aligned to the horizontal line of the screen. Then tighten the green DY.
 - * The green DY must be tightly fit to the CRT funnel.
 - * DY band tightening torque
8 to 12 kg/F-cm
6. Adjust the red and blue DYs in the same way.
7. Press the LIN key of the REGISTRATION and press the ADJ. G key.
8. Press the CUT OFF R key and B key to show green only.
9. Use the ◀ and ▶ keys of the arrow keys to change linearity between MIN and MAX and observe that both ends of the cross-hair change while maintaining a constant distance from the horizontal line of the screen. If a constant distance is not maintained, adjust angle of the sub DY until a constant distance between both ends of the cross-hair and the horizontal line of the screen is maintained. After completing adjustment, tighten the sub DY.
 - * The sub DY must be tightly fit to the DY.
 - * Sub DY band tightening torque
8 to 12 kg/F-cm
10. Adjust roughly linearity.
11. Press the CUT OFF R key and the G key to show red only. Adjust the red sub DY angle in the same way.
12. Press the CUT OFF B key and the R key to show blue only. Adjust the blue sub DY angle in the same way.
13. Adjust position of the green Mg focus until it is aligned with the green DY as shown. (Refer to Figure 4.)
 - * The Mg focus must be tightly fit to the sub DY.

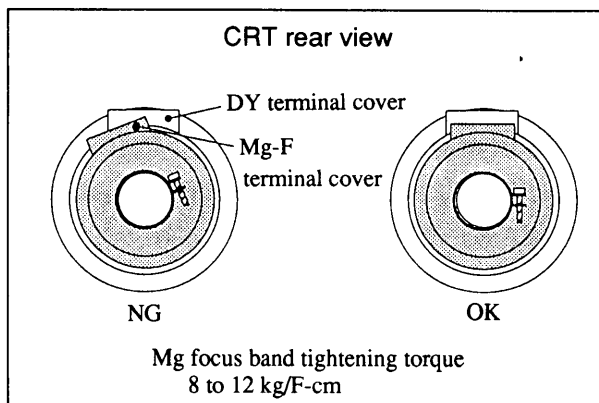

Figure 4

14. Adjust position of the red and blue Mg focuses in the same way.
15. Press the CUT OFF key to shown the three colors of R. G. and B.
16. Release the ED bracket stopper lock and close the ED bracket.

3-3-5. Registration Rough Adjustment

1. Confirm that the ED bracket is closed, and press the INPUT B key to disconnect all input signals.
2. Press the SIZE key of the REGISTRATION, and press the ADJ. G key.
3. Press the CUT OFF R key and B key to show green only.
4. Use the ◀, ▶, ▲, ▼ keys of the arrow keys until the outermost line of the cross-hair is positioned 20 to 40 m/m inside the outermost line of the effective display of the screen.
 - * If linearity error is found, adjust size and linearity until both size and linearity are correctly adjusted at the same time.
5. Press the KEY key and use the ◀, ▶, ▲, ▼ keys of the arrow keys to adjust the trapezoidal distortion.
6. Press the BOW key and use the ◀, ▶, ▲, ▼ keys of the arrow keys until the vertical and horizontal center lines become straight.
7. Press the SKEW key and use the ◀, ▶ keys of the arrow keys until the vertical line agrees with the vertical center line of the screen.
8. Press the PIN key and use the ▲, ▼ keys of the arrow keys until the upper and lower horizontal lines become straight.
9. Press the CUT OFF R key and ADJ. R key.
10. Adjust the red channel CENT, SIZE, LIN, BOW SKEW (H only), PIN and KEY until red image agrees with the green image in the same way.
11. Press the CUT OFF R key, B key and ADJ. B key.
12. Adjust the blue channel CENT, SIZE, LIN, BOW SKEW (H only), PIN and KEY until blue image agrees with the green image in the same way.
13. Press the NORMAL key.
14. Press the CUT OFF R key to show the R, G, and B colors.
15. Press the TEST key to show the cross hatch signal.
16. Confirm that registration of red, green and blue is approximately adjusted.
17. Press the NORMAL key.

3-3-6. 2-pole/4-pole Magnet Adjustment

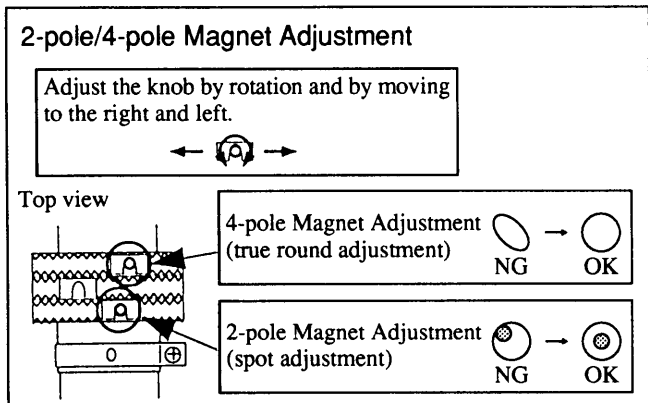

Figure 5

1. Press the INPUT B key to disconnect all input signals.
2. Press the TEST key to show the cross hatch signal.
3. Open the ED bracket and place a shield plate which is equivalent to the ED bracket on top of the DY.
4. Press the FOCUS MG key. Press the ADJ. G key to enter the G. ALL of the MG FOCUS adjustment mode.
5. Confirm that the display shown in Figure 6 appears on screen.

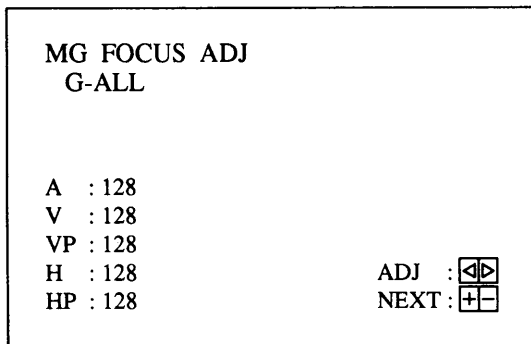

Figure 6

6. Press the TEST key to show the internal dot signal.
7. Press the ◀ key of the arrow keys until data A becomes MIN, and flare appears around the dots.
8. Press the CUT OFF R and B keys to show the green color only.
9. Observe the dot at the center of screen and adjust 2-pole magnet until the bright spot comes to the center of flare.
10. Press the ▶ key of the arrow keys until data A becomes MAX.
11. Adjust the 4-pole magnet until dot becomes true round.
12. Adjust the 2-pole and 4-pole magnets several times until both adjustments are satisfied at the same time.

* The 2-pole and 4-pole magnets must be tightly fit to the FOCUS magnet.

13. Adjust the 2-pole and 4-pole magnets of red and blue channels in the same way.

14. Coat the 2-pole and 4-pole magnets of red, green and blue channels with the RTV and fix them. (See Figure 7.)

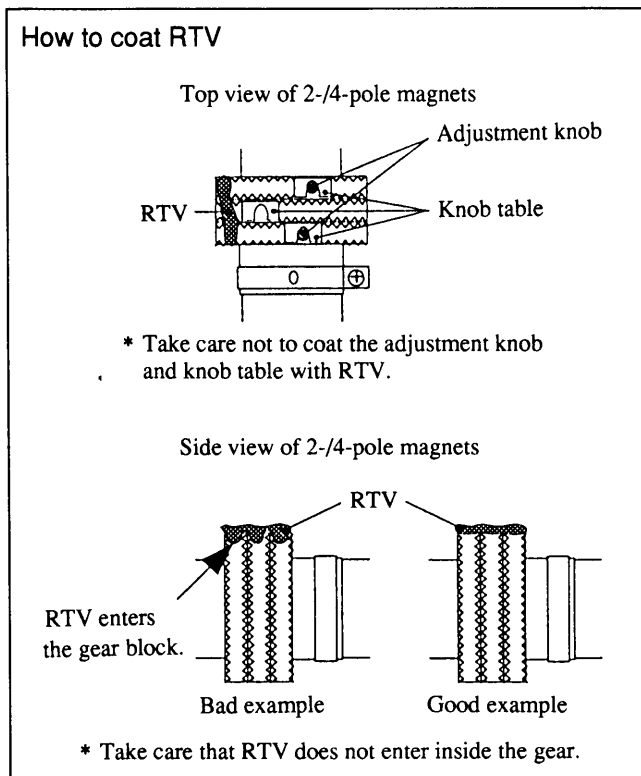

Figure 7

15. Press the CENT key and arrow keys until centers of the red, green and blue channels agree.
16. Press the MEMORY key.

3-3-7. VIDEO Center Size Adjustment

1. Press the INPUT VIDEO key to input and show the monoscope signal.
2. Press the SHIFT keys of RGB channels. Use the ◀, ▶ keys of the arrow keys until H center of the monoscope signal agrees with the center of screen.
 - * If V. centers of the RGB channels have error, adjust the V. center again using DA board RV4.
3. Press the SIZE key of the RGB channels and use the ◀, ▶, ▲, ▼ keys of the arrow keys until the H. size and V. size of RGB channels agree.
 - * H. and V. size adjustment specification using monoscope signal

H. size 16 ±0.15 divisions
V. size 12 ±0.15 divisions

4. Press the MEMORY key.

3-3-8. Standard Data Save

1. Keep pressing the MEMORY key for 5 seconds or longer and confirm that the message as shown in Figure 8 appears.

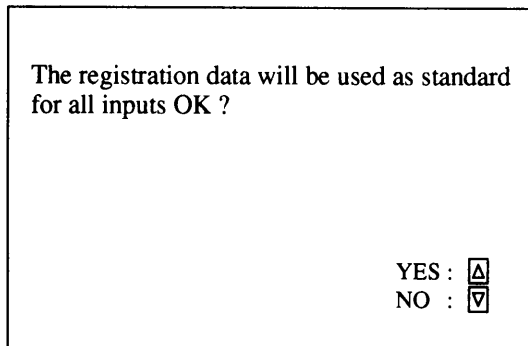

Figure 8

2. Press the ▲ key of the arrow keys to save the standard data.

3-3-9. Centering Adjustment During No Input Signal

1. Press the INPUT A key to receive and show the RGB signal of fH: 35 kHz.
2. Open the ED bracket. Set the 4th switch of SW-1 on the Y board to OFF (lower) position. Close the bracket.
3. Press the CENT R key and B key to enter the green center adjusting adjustment.
4. Use the ◀, ▶, ▲, ▼ keys of the arrow keys until vertical line and horizontal line of the cross hair agree with the center lines of the screen.
5. Press the INPUT B key to remove all input signals.
6. Press the SHIFT key of the RGB channels. Press the TEST key to show the cross hair signal.
7. Press the CUT OFF R key and B key to show the green color only.
8. Use the ◀, ▶ keys of the arrow keys so that the vertical line of the cross hair agrees with the center line of the screen.
9. Press the MEMORY key.
10. Open the ED bracket. Set the 4th switch of SW-1 on the Y board to ON (upper) position. Close the bracket.
11. Press the NORMAL key.

3-3-10. HWC Adjustment

1. Press the INPUT VIDEO key to receive and show the monoscope signal.
2. Select the SIZE key of the REGISTRATION, and press the ADJ. G key.
3. Confirm that the H. size data is 128.
 - * If the data is not 128, press the ◀, ▶ keys of the arrow keys to obtain the data 128.
4. Press the ADJ. R key and confirm that the H. size data is 128.
5. Press the ADJ. B key and confirm that the H. size data is 128.
6. Press the CENT R key and B key at the same time to enter the green center adjustment mode.
7. Use the ◀, ▶, ▲, ▼ keys of the arrow keys until vertical and horizontal lines agree with the center lines of the screen.
8. Press the ADJ. R key and the red channel center in the same way.
9. Press the ADJ. B key and the blue channel center in the same way.
10. Press the MEMORY key.
11. Find the channel having the biggest H. size between the red, green and blue channels. Adjust HWC of the E board until the H. sizes of the remaining two colors agree with the biggest H. size.
 - * The HWCs are shipped at the MAX (its core is set in the deepest end position) before adjustment. When making adjustment, turn the HWC in counter-clockwise direction.
12. Press the SHIFT key of the RGB channels.
13. Use the ◀ and ▶ keys of the arrow keys until vertical line agrees with the center lines of the screen.
14. Press the MEMORY key.
15. Press the SIZE key of REGISTRATION. Keep pressing the TEST key for five seconds or longer to show the monoscope signal.
16. Keep pressing the ▶ key of the arrow keys until the H. size becomes MAX.
17. Press the LIN key. Use the ◀, ▶ keys of the arrow keys to adjust roughly linearity in the left and right.
 - * If the H. center of the monoscope signal has centering error, re-adjust it.
18. Adjust RV104 on the E board until the H. size of monoscope signal becomes 15 divisions.
19. Press the SIZE key of RGB. Press the CUT OFF R key and the B key to show green color only.
20. Use the ◀, ▶ keys of the arrow keys until the H. size of monoscope signal becomes 16 divisions.

21. Use the ▲, ▼ keys of the arrow keys until the V. size of monoscope signal becomes approximately 12 divisions.
22. Open the ED bracket. Adjust RV5 on the DA board until the horizontal center line of the monoscope signal agrees with the center line of the screen. (See Figure 9.)

* The V. center position is affected by opening and closing of the ED bracket. The V. centers of two signals must agree when the ED bracket is closed.

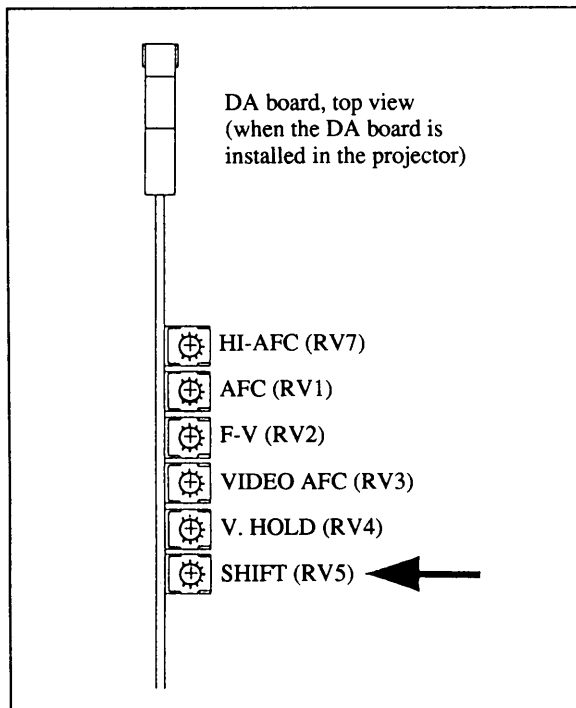

Figure 9

23. Use the ▲, ▼ keys of the arrow keys again until the V. size of monoscope signal becomes 12 divisions.
24. Press the R key of CENT. Press the CUT OFF B key.
25. Use the ◀, ▶, ▲, ▼ keys of the arrow keys until vertical line and horizontal line of the cross hair signal agree with vertical line and horizontal line of the green signal.
26. Press the CUT OFF B key and R key. Press the ADJ. B key and adjust the blue center in the same way.
27. Press the MEMORY key.
28. Press the NORMAL key.

3-3-11. Mg FOCUS/4-pole Mg Adjustment During No Input Signal

1. Press the INPUT B key to disconnect all input signals.
2. Press the FOCUS MG key to enter the Mg FOCUS adjustment mode. Confirm that the display as shown in Figure 10 appears.

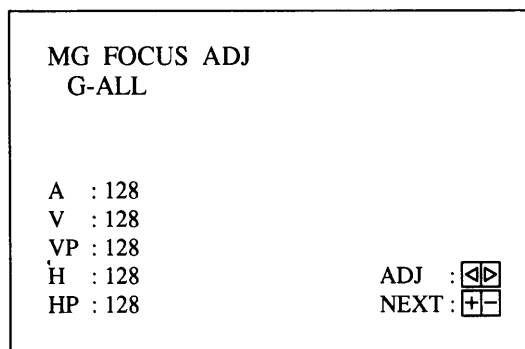

Figure 10

3. Press the ◀, ▶ keys of the arrow keys so that H. pattern in the center of screen has the best focus in the G-ALL adjustment mode.
4. Adjust the green main lens so that center of screen has the best focus and fix the main lens.
5. Repeat step (3) adjustment.
6. Press the POSITION (+) key to enter the G-V adjustment mode.
7. Keep pressing the ▶ key of the arrow keys so that the H. pattern at the vertical center is de-focused.
8. Press the POSITION (+) key to enter the V-PHASE adjustment mode.
9. Press the ◀, ▶ keys of the arrow keys so that degree of de-focus of the H. patterns in the upper and lower portions are equal.
10. Press the POSITION (-) key to return to the G-V adjustment mode.
11. Press the ◀, ▶ keys of the arrow keys so that the H. pattern at the vertical center has the best focus.
12. Adjust the green main lens until center of display has the best focus and fix the main lens.
13. Repeat the step 11 adjustment again.
14. Repeat the steps from 4 to 9 several times until the best focus is obtained in all adjustment points at the same time.
15. Press the POSITION (+) key to enter the G-H adjustment mode.
16. Keep pressing the ▶ key of the arrow keys so that the H. pattern at the horizontal center is de-focused.
17. Press the POSITION (+) key to enter the H-PHASE adjustment mode.
18. Press the ◀, ▶ keys of the arrow keys so that degree of de-focus of the H. patterns in the right and left portions are equal.
19. Press the POSITION (-) key to return to the G-H adjustment mode.

20. Press the ◀, ▶ keys of the arrow keys so that the H. pattern at the horizontal center has the best focus.
21. Repeat steps from 11 to 17 several times until the best focus is obtained at all adjustment points at the same time.
22. Press the POSITION (+) key to enter the AQP/DQP ADJ - POSITION: 1 adjustment mode. Confirm that the display shown in Figure 11 appears.

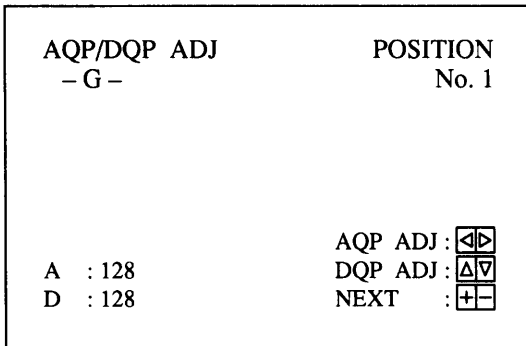
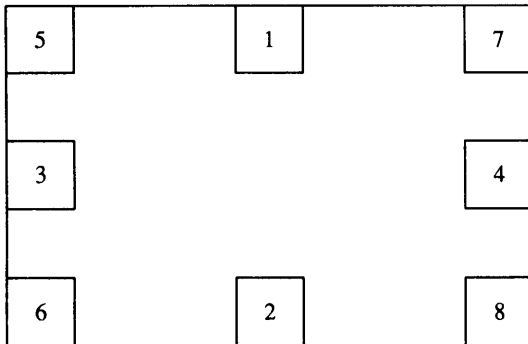

Figure 11

* See Figure 12 for location of POSITION.



* Numbers indicates locations of POSITIONs during AQP/DQP adjustment.

Figure 12

23. Use the ◀, ▶, ▲, ▼ keys of the arrow keys until the H. pattern in the center of the upper portion has the best focus at the same time.
24. Press the POSITION (+) key to enter the AQP/DQP ADJ - POSITION: 2 adjustment mode.
25. Use the ◀, ▶, ▲, ▼ keys of the arrow keys until the H. pattern in the center of the lower portion has the best focus.
26. Select the AQP/DQP ADJ - POSITION: 3 to 8 adjustment modes in the same manner as steps 21 and 22, and adjust until the H pattern has the best focus in each adjustment.
27. Press the ADJ. R key to enter the R-ALL - Mg FOCUS (4-pole) adjustment.

28. Press the ◀, ▶ keys of the arrow keys so that the H. pattern in the center has the best focus in the R-ALL adjustment mode.
29. Press the POSITION (+) key to enter the R-V adjustment mode.
30. Press the ◀, ▶ keys of the arrow keys so that the H. pattern at the vertical center has the best focus.
31. Press the POSITION (+) key to enter the R-H adjustment mode.
32. Press the ◀, ▶ keys of the arrow keys so that the H. pattern at the horizontal center has the best focus.
33. Select the blue channel and adjust the Mg FOCUS (4-pole) in the same manner.
34. Press the MEMORY key to store the Mg FOCUS (4-pole) adjustment data in memory.

3-3-12. 8 Block Mg FOCUS Fine Adjustment

1. Press the INPUT A key to input and show the RGB signal of fH: 15.7 kHz and fV: 60Hz.
2. Press the FOCUS MG key to enter the green channel Mg FOCUS adjustment mode.
3. Press the ◀, ▶ keys of the arrow keys so that H. pattern in the center of screen has the best focus.
4. Press the POSITION (+) key to enter the G-V adjustment mode.
5. Keep pressing the ▶ key of the arrow keys so that the H. pattern in the vertical center is de-focused.
6. Press the POSITION (+) key to enter the V-PHASE adjustment mode.
7. Press the ◀, ▶ keys of the arrow keys so that degree of de-focus of the H. patterns in the upper and lower portions are equal.
8. Press the POSITION (-) key to return to the G-V adjustment mode.
9. Press the ◀, ▶ keys of the arrow keys so that the H. pattern at the vertical center has the best focus.
10. Repeat the steps from 4 to 9 several times until the best focus is obtained in all adjustment points at the same time.
11. Press the POSITION (+) key to enter the G-H adjustment mode.
12. Keep pressing the ▶ key of the arrow keys so that the H. pattern at the horizontal center is de-focused.
13. Press the POSITION (+) key to enter the H-PHASE adjustment mode.
14. Press the ◀, ▶ keys of the arrow keys so that degree of de-focus of the H. patterns in the right and left portions are equal.
15. Press the POSITION (-) key to enter the G-H adjustment mode.
16. Press the ◀, ▶ keys of the arrow keys so that the H. pattern at the horizontal center has the best focus.
17. Repeat steps from 11 to 16 several times until the best focus is obtained at all adjustment points at the same time.
18. Press the ADJ. R key to enter the RED Mg FOCUS - R-All adjustment mode.

19. Press the ◀, ▶ keys of the arrow keys so that the H. pattern at the center has the best focus.
20. Press the POSITION (+) key to enter the R-V adjustment mode.
21. Press the ◀, ▶ keys of the arrow keys so that the H. pattern at the vertical center has the best focus.
22. Press the POSITION (+) key to enter the R-H adjustment mode.
23. Press the ◀, ▶ keys of the arrow keys so that the H. pattern at the horizontal center has the best focus.
24. Press the ADJ. B key to enter the BLUE Mg FOCUS - B-All adjustment mode.
25. Press the ◀, ▶ keys of the arrow keys so that the H. pattern at the center has the best focus.
26. Press the POSITION (+) key to enter the R-V adjustment mode.
27. Press the ◀, ▶ keys of the arrow keys so that the H. pattern at the vertical center has the best focus.
28. Press the POSITION (+) key to enter the R-H adjustment mode.
29. Press the ◀, ▶ keys of the arrow keys so that the H. pattern at the horizontal center has the best focus.
30. Press the MEMORY key to save the Mg FOCUS data of the REG BLOCK No.1 in memory.
31. Switch the RGB input to fH: 31.5 kHz, fH: 48 kHz, fH: 64 kHz, fH: 76 kHz, fH: 89 kHz, fH: 126 kHz and perform the Mg FOCUS adjustment for each fH (REG BLOCK) in the same way as the steps from 1 to 30. Save the adjustment data in memory.

10. Enter the each mode of LIN, SKEW, BOW, KEY, PIN and ZONE (as to ZONE, adjust No. 2 to 9 blocks only out of 21 blocks), and adjust them until registration satisfies the specification (as shown in Figure 13) using the arrow keys.

* If size causes error, correct it by size adjustment as necessary.

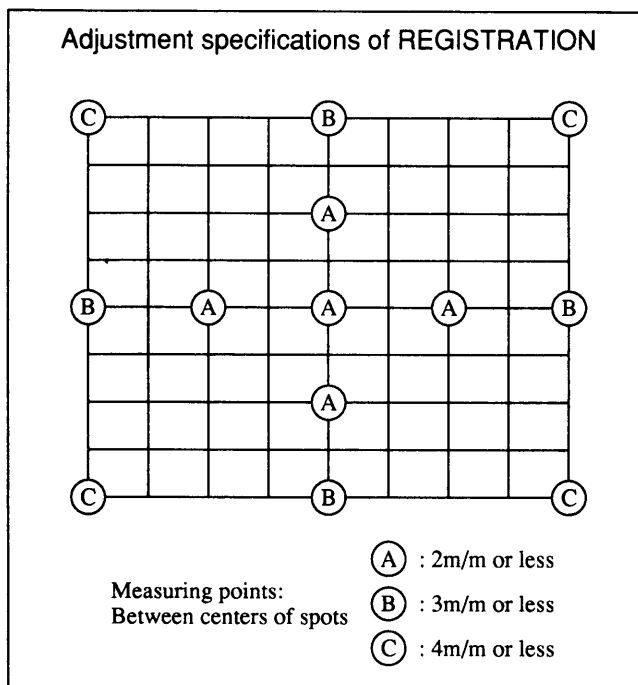

Figure 13

3-4. REGISTRATION ADJUSTMENT

3-4-1. 8 Block Adjustment

1. Press the INPUT A key to input and show the RGB signal of fH: 15.7 kHz.
2. Press the BLKG key to move the upper blanking out of the effective screen using the arrow key ▲.
3. Press the POSITION (+) key to move the lower blanking out of the effective screen using the arrow key ▼.
4. Press the POSITION (+) key to move the left blanking out of the effective screen using the arrow key ◀.
5. Press the POSITION (+) key to move the right blanking out of the effective screen using the arrow key ▶.
6. Press the MEMORY key.
7. Press the CENT R key and B key at the same time to enter the green adjustment mode.
8. Use the ◀, ▶, ▲, ▼ keys of the arrow keys to adjust the vertical lines and horizontal line until they agree with the center lines of the screen.
9. Press the SIZE key of REGISTRATION. Use the ◀, ▶, ▲, ▼ keys of the arrow keys to adjust the outer edge of the cross hair signal until they are positioned about 30 m/m inside the screen.

11. Press the MEMORY key.
12. Press the CENT R key. Adjust the vertical and horizontal lines of the red channel so that they agree with the green center lines using the ◀, ▶, ▲, ▼ keys of arrow keys.
13. Press the SIZE key of REGISTRATION. Use the ◀, ▶, ▲, ▼ keys of the arrow keys to adjust the outer edge of the cross hair signal until they are positioned about 30 m/m inside the screen.
14. Enter the each mode of LIN, SKEW, BOW, KEY, PIN and ZONE (as to ZONE, adjust No. 2 to 9 blocks only out of 21 blocks), and adjust them until registration satisfies the specification using the arrow keys.

* If size causes error, correct it by size adjustment as necessary.

15. Press the MEMORY key.
16. Adjust the blue channel in the same way, and store the data in memory.
17. Switch the RGB input to fH: 31.5 kHz, fH: 35 kHz, fH: 48 kHz, fH: 64 kHz, fH: 76 kHz, fH: 89 kHz, fH: 126 kHz and perform the green, red and blue channel registration in the same way as fH: 15.7 kHz, and store the data in memory.

3-5. WHITE BALANCE ADJUSTMENT

3-5-1. Color Temperature 9300°K Adjustment

(Chromaticity diagram: $x = 0.284$, $y = 0.297$)

1. Press the INPUT VIDEO key to input and display the all white signal of 100 IREs.
2. Press the PAGE key to show the PAGE 3 display.
3. Press the ◀, ▶ keys of arrow keys to select 9300. Press the MEMORY key to store it in memory.
4. Press the GAIN key of W/B. Press the ADJ. R key to enter the red adjustment mode.
5. Press the ◀, ▶ keys of arrow keys to select 135 on display.
6. Press the ADJ. G key to enter the green adjustment mode.
7. Press the ◀, ▶ keys of arrow keys to select 195 on display.
8. Press the ADJ. B key to enter the blue adjustment mode.
9. Press the ◀, ▶ keys of arrow keys to select MAX on display.
10. Select the all white signal of 10 IREs.
11. Press the BIAS key. Keep pressing TEST key for five seconds or longer to show the all white signal of 10 IREs.
12. Press the STATUS OFF key to delete the display. Attach the sensor of the W/B measuring equipment.

* W/B measuring equipment (color analyzer)

Model: PWB-801 (made by Sony Corp.)

Calibration coefficient R/G: 1.082

B/G: 0.980

13. Press the ADJ. G key. Use the ◀, ▶ keys of arrow keys until the Y value of the W/B measuring equipment becomes 1.00.
14. Press the ADJ. R key. Use the ◀, ▶ keys of arrow keys until the R/G value of the W/B measuring equipment becomes 1.00.
15. Press the ADJ. B key. Use the ◀, ▶ keys of arrow keys until the B/G value of the W/B measuring equipment becomes 1.00.
16. Select the all white signal of 100 IREs.
17. Press the GAIN key to enter the gain adjustment mode.
18. Press the ADJ. B key. Use the ◀, ▶ keys of arrow keys until the B/G value of the W/B measuring equipment becomes 1.00.
19. Press the ADJ. R key. Use the ◀, ▶ keys of arrow keys until the R/G value of the W/B measuring equipment becomes 1.00.
20. Repeat the cut-off adjustment from steps 10 to 15, and the high light adjustment from steps 16 to 19 several times until all these adjustments are satisfied at the same time.

21. If the value satisfying the specification is obtained, press the MEMORY key and store the 9300°K data in memory.

* W/B 9300°K + 8MPCD specifications

Cut-off R/G: 1.00 ±0.15

B/G: 1.00 ±0.15

Y : 2.50 ±0.15

High light R/G: 1.00 ±0.10

B/G: 1.00 ±0.10

22. Remove sensor from lens.

3-5-2. Color Temperature 6500°K Adjustment

(Chromaticity diagram: $x = 0.313$, $y = 0.329$)

1. Press the INPUT VIDEO key to input and display the all white signal of 100 IREs.
2. Press the PAGE key to show the PAGE 3 display.
3. Press the ◀, ▶ keys of arrow keys to select 6500. Press the MEMORY key to store it in memory.
4. Press the GAIN key of W/B. Press the ADJ. R key to enter the red adjustment mode.
5. Press the ◀, ▶ keys of arrow keys to select 200 on display.
6. Press the ADJ. G key to enter the green adjustment mode.
7. Press the ◀, ▶ keys of arrow keys to select 230 on display.
8. Press the ADJ. B key to enter the blue adjustment mode.
9. Press the ◀, ▶ keys of arrow keys to select 230 on display.
10. Select the all white signal of 10 IREs.
11. Press the BIAS key. Keep pressing TEST key for five seconds or longer to show the all white signal of 10 IREs.
12. Press the STATUS OFF key to delete the display. Attach the sensor of the W/B measuring equipment.
13. Press the ADJ. G key. Use the ◀, ▶ keys of arrow keys until the Y value of the W/B measuring equipment becomes 1.00.
14. Press the ADJ. R key. Use the ◀, ▶ keys of arrow keys until the R/G value of the W/B measuring equipment becomes 1.16.
15. Press the ADJ. B key. Use the ◀, ▶ keys of arrow keys until the B/G value of the W/B measuring equipment becomes 0.72.
16. Select the all white signal of 100 IREs.
17. Press the GAIN key to enter the gain adjustment mode.
18. Press the ADJ. R key. Use the ◀, ▶ keys of arrow keys until the R/G value of the W/B measuring equipment becomes 1.16.
19. Press the ADJ. B key. Use the ◀, ▶ keys of arrow keys until the B/G value of the W/B measuring equipment becomes 0.72.
20. Repeat the cut-off adjustment from steps 10 to 15, and the high light adjustment from steps 16 to 19 several times until all these adjustments are satisfied at the same time.

21. If the value satisfying the specification is obtained, press the MEMORY key and store the 6500°K data in memory.

- * W/B 6500°K + 8MPCD specifications
- Cut-off R/G: 1.15 ±1.15
 B/G: 0.75 ±0.15
 Y : 3.00 ±0.10
- High light R/G: 1.15 ±1.10
 B/G: 0.75 ±0.10

22. Remove sensor from lens.

3-5-3. Color Temperature 5400°K Adjustment
(Chromaticity diagram: x = 0.335, y = 0.349)

1. Press the INPUT VIDEO key to input and display the all white signal of 100 IREs.
2. Press the PAGE key to show the PAGE 3 display.
3. Press the ◀, ▶ keys of arrow keys to select 5400. Press the MEMORY key to store it in memory.
4. Press the GAIN key of W/B. Press the ADJ. R key to enter the red adjustment mode.
5. Press the ◀, ▶ keys of arrow keys to select 220 on display.
6. Press the ADJ. G key to enter the green adjustment mode.
7. Press the ◀, ▶ keys of arrow keys to select 230 on display.
8. Press the ADJ. B key to enter the blue adjustment mode.
9. Press the ◀, ▶ keys of arrow keys to select 180 on display.
10. Select the all white signal of 10 IREs.
11. Press the BIAS key. Keep pressing TEST key for five seconds or longer to show the all white signal of 10 IREs.
12. Press the STATUS OFF key to delete the display. Attach the sensor of the W/B measuring equipment.
13. Press the ADJ. G key. Use the ◀, ▶ keys of arrow keys until the Y value of the W/B measuring equipment becomes 1.00.
14. Press the ADJ. R key. Use the ◀, ▶ keys of arrow keys until the R/G value of the W/B measuring equipment becomes 1.28.
15. Press the ADJ. B key. Use the ◀, ▶ keys of arrow keys until the B/G value of the W/B measuring equipment becomes 0.56.
16. Select the all white signal of 100 IREs.
17. Press the GAIN key to enter the gain adjustment mode.
18. Press the ADJ. R key. Use the ◀, ▶ keys of arrow keys until the R/G value of the W/B measuring equipment becomes 1.28.
19. Press the ADJ. B key. Use the ◀, ▶ keys of arrow keys until the B/G value of the W/B measuring equipment becomes 0.56.
20. Repeat the cut-off adjustment from steps 10 to 15, and the high light adjustment from steps 16 to 19 several times until all these adjustments are satisfied at the same time.

21. If the value satisfying the specification is obtained, press the MEMORY key and store the 5400°K data in memory.

- * W/B 5400°K + 8MPCD specifications
- Cut-off R/G: 1.39 ±0.15
 B/G: 0.64 ±0.15
 Y : 3.00 ±0.10
- High light R/G: 1.39 ±0.10
 B/G: 0.64 ±0.10

22. Remove sensor from lens.

3-5-4. Color Temperature 3200°K Adjustment
(Chromaticity diagram: x = 0.427, y = 0.408)

1. Press the INPUT VIDEO key to input and display the all white signal of 100 IREs.
2. Press the PAGE key to show the PAGE 3 display.
3. Press the ◀, ▶ keys of arrow keys to select 3200. Press the MEMORY key to store it in memory.
4. Press the GAIN key of W/B. Press the ADJ. R key to enter the red adjustment mode.
5. Press the ◀, ▶ keys of arrow keys to select MAX on display.
6. Press the ADJ. G key to enter the green adjustment mode.
7. Press the ◀, ▶ keys of arrow keys to select 170 on display.
8. Press the ADJ. B key to enter the blue adjustment mode.
9. Press the ◀, ▶ keys of arrow keys to select 10 on display.
10. Select the all white signal of 10 IREs.
11. Press the BIAS key. Keep pressing TEST key for five seconds or longer to show the all white signal of 10 IREs.
12. Press the STATUS OFF key to delete the display. Attach the sensor of the W/B measuring equipment.
13. Press the ADJ. G key. Use the ◀, ▶ keys of arrow keys until the Y value of the W/B measuring equipment becomes 1.00.
14. Press the ADJ. R key. Use the ◀, ▶ keys of arrow keys until the R/G value of the W/B measuring equipment becomes 2.25.
15. Press the ADJ. B key. Use the ◀, ▶ keys of arrow keys until the B/G value of the W/B measuring equipment becomes 0.22.
16. Select the all white signal of 100 IREs.
17. Press the GAIN key to enter the gain adjustment mode.
18. Press the ADJ. R key. Use the ◀, ▶ keys of arrow keys until the R/G value of the W/B measuring equipment becomes 2.25.
19. Press the ADJ. B key. Use the ◀, ▶ keys of arrow keys until the B/G value of the W/B measuring equipment becomes 0.22.
20. Repeat the cut-off adjustment from steps 10 to 15, and the high light adjustment from steps 16 to 19 several times until all these adjustments are satisfied at the same time.

21. If the value satisfying the specification is obtained, press the MEMORY key and store the 3200°K data in memory.

- * W/B 3200°K + 8MPCD specifications
 - Cut-off R/G: 2.30 ±0.15
 - B/G: 0.23 ±0.15
 - Y : 2.50 ±0.10
 - High light R/G: 2.30 ±0.10
 - B/G: 0.23 ±0.10

22. Remove sensor from lens.
 23. Press the STATUS ON key. Press the PAGE key to show the PAGE3 screen.
 24. Select 6500 and press the MEMORY key.

3-6. BLANKING ADJUSTMENT

3-6-1. RGB Blanking Adjustment

1. Press the INPUT-A key to input and show the RGB signal of fH: 15.7 kHz, fV: 60 Hz.
 2. Keep pressing the BRIGHT (+) key until level becomes MAX.
 3. Press the BLKG key to enter the upper blanking adjustment mode. Confirm that the display shown in Figure 14 appears.

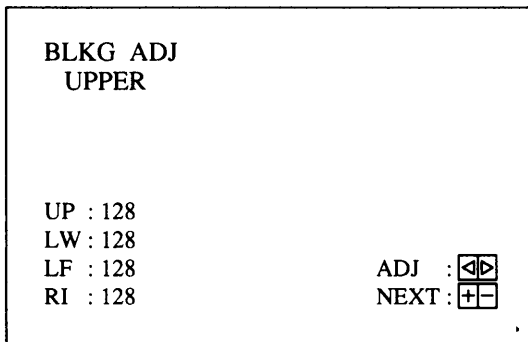

Figure 14

4. Press the TEST key to show the internal cross hatch signal.
 5. Use the ▲, ▼ keys of the arrow keys until the upper blanking is positioned 40 m/m out of the effective screen.

- * Adjustment specifications of BLANKING.
40 ±10m/m

6. Press the POSITION (+) key to enter the lower blanking adjustment mode.

7. Use the ▼, ▲ keys of the arrow keys until the lower blanking is positioned 40 m/m out of the effective screen.

- * Adjustment specifications of BLANKING.
40 ±10m/m

8. Press the POSITION (+) key to enter the left blanking adjustment mode.

9. Use the ◀, ▶ keys of the arrow keys until the left blanking is positioned 40 m/m out of the effective screen.

- * Adjustment specifications of BLANKING.
40 ±10m/m

10. Press the POSITION (+) key to enter the right blanking adjustment mode.

11. Use the ▶, ◀ keys of the arrow keys until the right blanking is positioned 40 m/m out of the effective screen.

- * Adjustment specifications of BLANKING.
40 ±10m/m

12. Press the MEMORY key to store the blanking data at fH: 15.7 kHz in memory.

13. Switch the RGB input to fH: 31.5 kHz, fH: 35 kHz, fH: 48 kHz, fH: 64 kHz, fH: 76 kHz, fH: 89 kHz, fH: 126 kHz and perform the blanking adjustment in the same way as fH: 15.7 kHz, and store the data in memory.

3-7. HIGH-VOLTAGE PICTURE BENDING ADJUSTMENT

3-7-1. RV2101 Adjustment

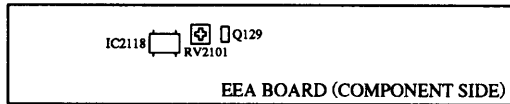

1. Press the INPUT A key to receive and show the RGB stripe signal of fH: 31.5 kHz.
2. Keep pressing the CONTR and BRIGHT (+) keys until their levels become MAX.
3. Adjust RV2101 on the EEA board (grand-son board of E board) until the vertical lines in the right and left become straight.

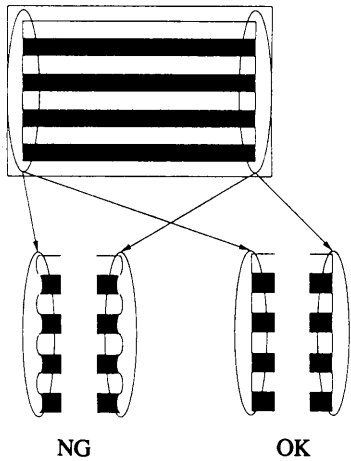

Figure 15

SECTION 4 SAFETY RELATED ADJUSTMENTS

If the following parts which are identified by mark are replaced, check the HV Regulation circuit, HV Hold Down circuit and IK Protector circuit.

- RV1 [HV Regulation] PA Board
- IC1, IC7, IC8, IC9, IC10, IC11, IC12, IC13, R38, R39, R63, R64, R65, R66, R69, R72, R78, R80, R132, X1 PA Board Mounted PA Board, PB Board, HV Block

- RV2 [HV Hold Down] PA Board
- IC2, D9, D12, C13, R20, R21, R22, R23, R24, R32, R33, R35, R36, R82 PA Board Mounted PA Board, HV Block

- RV301 [IK Protector] CBR
- RV401 [IK Protector] CBG
- RV501 [IK Protector] CBB
- IC303, IC304, D303, R330, R331, R332, R333, R334, R348 CBR Board IC403, IC404, D403, R430, R431, R432, R433, R434, R448 CBG Board IC503, IC504, D503, R530, R531, R532, R533, R534, R548 CBB Board Mounted CBR Board, CBG Board, CBB Board, HV Block

RV1, RV2 : HV Protector, HV Regulator Check

1. Input the monoscope signal.
2. Keep pressing the CONT (+) key on the control panel until CONT becomes maximum. Keep pressing the BRIGHT (+) key on the control panel until BRIGHT becomes maximum.
3. Adjust RV3 (total ABL) on the PA board until the ABL current becomes 4 mA.
 - * Specification of the total ABL current
4.0 to 4.1 mA
4. Turn RV1 (HV-REG) on the PA board slowly counter-clockwise so that the high voltage becomes 34 kV.
 - * Specification of high voltage for HV-PROT adjustment
34 ± 0.3 kV
5. Turn RV2 (HV-PROT) slowly clockwise and stop turning RV2 when high voltage disappears.
(The power is turned off a few seconds later.)
6. Turn RV1 clockwise small increment until the power is turned on.
7. Keep pressing the CONT (-) key on the control panel until CONT becomes minimum. Keep pressing the BRIGHT (-) key on the control panel until BRIGHT becomes minimum.

8. Turn RV1 (HV-REG) on the PA board slowly clockwise so that the high voltage becomes 33 kV.

* High voltage adjustment specification (for cut-off)
33 ± 0.3 kV

9. Check again that the total ABL current is 4 mA.
If the total ABL current is other than 4 mA, repeat steps from 2 to 8.
10. Turn off the main power to the projector. Coat entire surface of the anti-rotation caps on top of RV1, RV2 and RV3 with RTV. Then fix them. (See Figure 1.) (Coat the adjustment controls fully with RTV.)

* RV3 does not have the anti-rotation cap. Coat RV3 fully with RTV until the adjustment point on top of RV3 is covered.

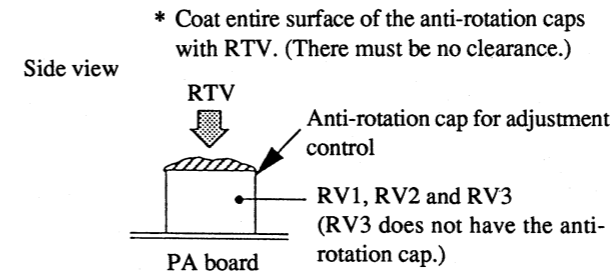

Figure 1

11. Turn on the main power to the projector. Check that the high voltage stays within the specification.

* High voltage adjustment specification (for cut-off)
33 ± 0.3 kV

12. Keep pressing the CONT (+) key on the control panel until CONT becomes maximum. Keep pressing the BRIGHT (+) key on the control panel until BRIGHT becomes maximum.
13. Connect a tool VR (variable resistor) for the HV protector operation check, between TP16 and TP18. (See Figure 2.)

* Turn the tool VR (variable resistor) for the maximum resistance value before connection.

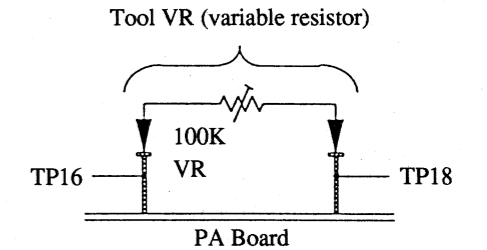
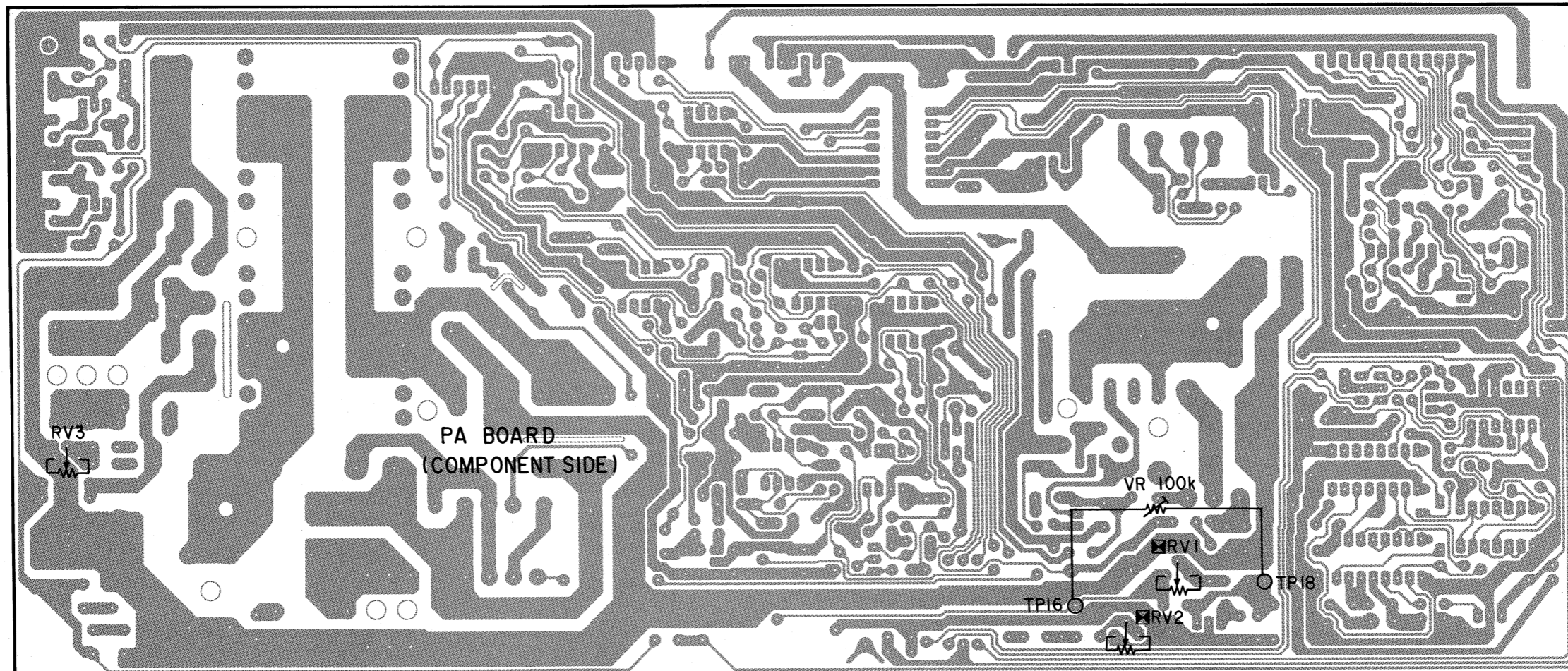

Figure 2



14. Adjust the tool VR (variable resistor) slowly and check to see that the high voltage drops when the high voltage reaches 34 kV.

* The main power is turned off a few seconds later.

* Specification of high voltage for HV-PROT operation check
34 ± 0.3 kV

15. Remove the tool VR (variable resistor) and turn on the main power to the projector.

16. Decrease the CONTR and BRIGHT to the minimum, then increase the CONTR and BRIGHT to the maximum, and check that the high voltage deviation stays within the specification.

Specification of high voltage deviation

33 +0.2 kV
-0.5 kV

* If the high voltage deviation is outside the specification range, repeat steps from 2 to 16.

* If RV1 and RV2 need to be adjusted, replace the adjustment controls and the anti-rotation caps, then make adjustment.

17. Press the RESET key to return the CONTR and BRIGHT controls to the normal settings.

RV301, RV401, RV501 : IK Protector Check

1. Check that the main power is turned off.
2. Remove CN522 (3-pin micro-connector) from the EB (RG) board, and turn on the main power.
3. Input and display the all white signal.
4. Press the G and B keys of the CUT OFF key to select red only.
5. While watching the ammeter measuring the ABL current, keep pressing the CONTR (+) key. Confirm that the protector is activated within the specification range of the IK protector current, and also check that the main power is turned off.

IK protector activation current specification
2.6 to 3.3 mA

6. Turn on the main power. Press the RESET key to return the CONTR to 80%.
7. Press the R and B keys of the CUT OFF key to select green only.
8. Confirm that the protector is activated within the specification range of the IK protector current, in the same way as step 5.
9. Turn on the main power. Press the RESET key to return the CONTR to 80%.
10. Press the R and G keys of the CUT OFF key to select blue only.
11. Confirm that the protector is activated within the specification range of the IK protector current, in the same way as step 5.
12. Turn off the main power. Connect the 3-pin micro-connector to CN522 of the EB (RG) board. Turn on the main power.
13. Press the RESET key to return the CONTR to 80%.

+B MAX. VOLTAGE CONFIRMATION

1. Input a monoscope signal.
2. Put R.G.B. cut off switch ON.
3. Input voltage is 130.0 VAC.

Note 1: Use NF Power Supply or make sure that distortion factor is 3% or less.

4. Confirm that +B MAX VOLTAGE satisfies the standard.

Standard: 115.0 ± 2.0 VDC

CONFIRMATION WHEN REPLACING POWER SUPPLY BLOCK

Confirm that the voltage of +B Max. voltage is within the standard value when replacing Power Supply Block.

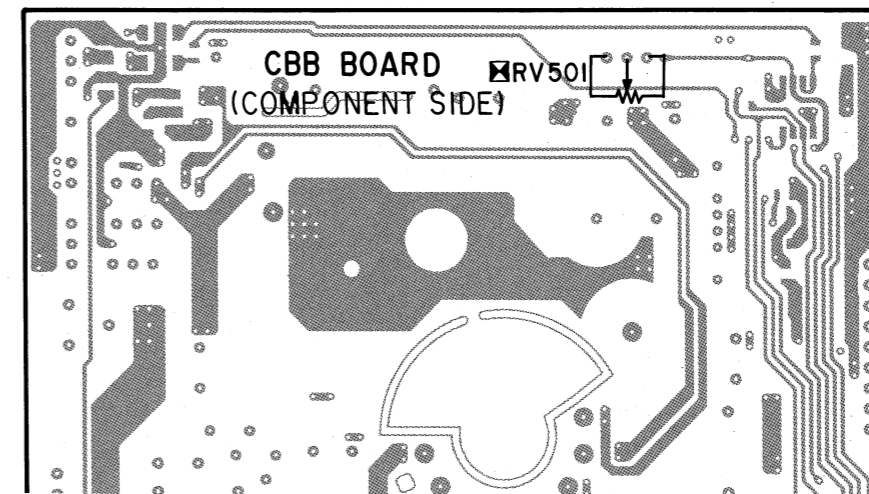
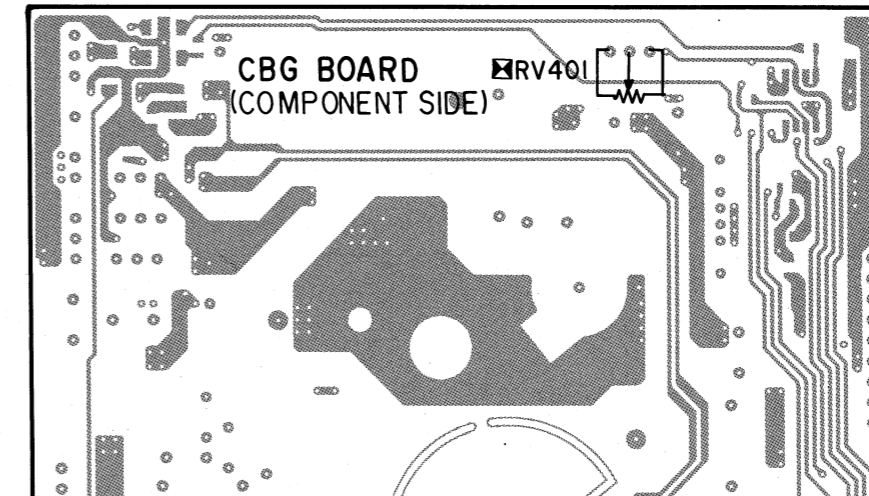
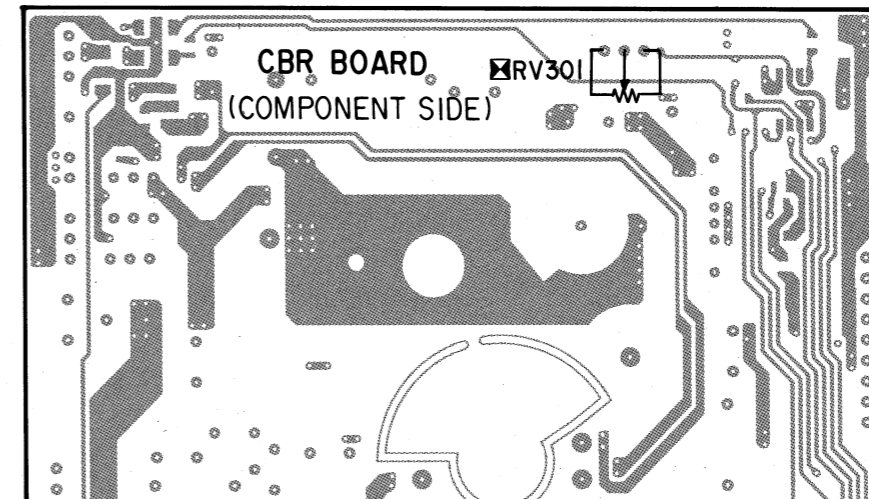

SECTION 5 ELECTRICAL ADJUSTMENT

5-1. CAR, CAG, CAB, CBR, CRG AND CBB BOARD ADJUSTMENT

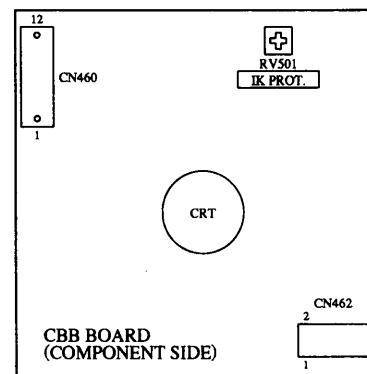
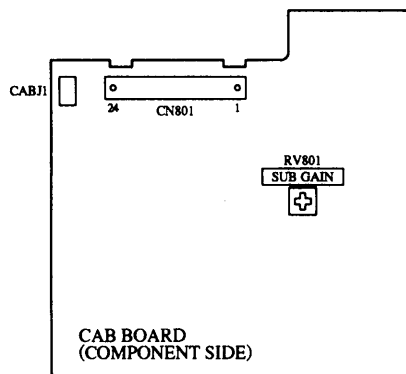
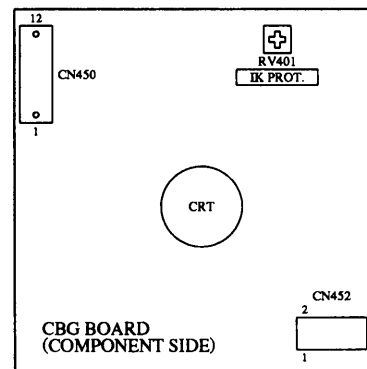
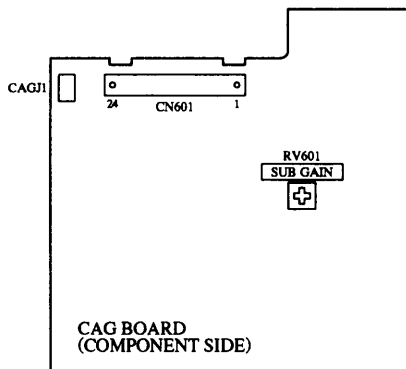
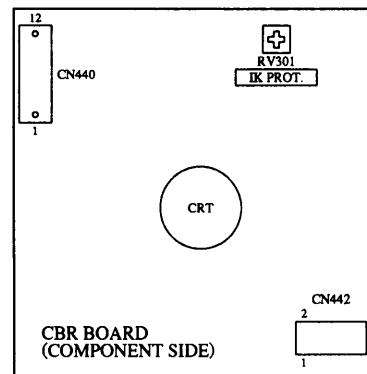
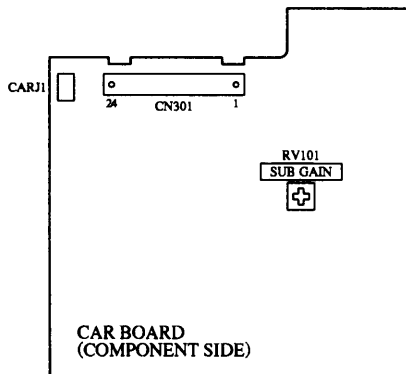

Introduction

The CAR, CAG, CAB boards and the CBR, CBG, CBB boards have almost identical circuitry respectively. The adjustments for these boards are therefore identical in the [CAR, CBR] block, [CAG, CBG] block and [CAB, CBB] block.

This guide describes how to adjust the [CAG, CBG] block only and the reference numbers for parts and connectors of the remaining blocks are shown in parentheses for the other two blocks respectively. The adjustment procedures for all three blocks are thus shown, as outlined in the example below.

example

[CAR, CBR] block (303)
 [CAG, CBG] block CN603
 [CAB, CBB] block <803>

5-1-1. Power Supply Connection

1. Connect the CAG board to the CBG board.
2. Connect the power supply as follows.

CAR board

CN601(301)<801>	10pin	+12 ⁺⁰ _{-0.2} V
	11pin	+9 ±0.2V
	12pin	-12 ±0.2V
	8, 9, 13, 14pin	GND

CBR board

CN450(440)<460>	3pin	+103 ±2V
	8pin	-160 ±5V
	5, 6pin	GND
CN452(442)<462>	GND

3. Connect the control signal to the input as shown below.

Initial state:

Set the CONTRAST, BRT, DRV, and BKG input controls to 0 V.

CAG board

- CN601(301)<801> 2pin CONTRAST

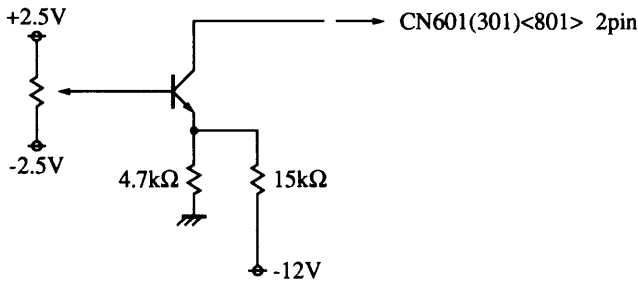

- CN601(301)<801> 3pin BRT
- 4pin DRV
- 5pin BKG

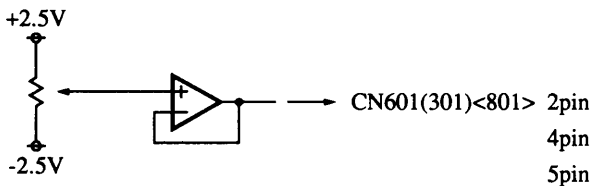

Initial state:

Set the ON/OFF switch to the open position.

- CN601(301)<801> 23pin ON/OFF

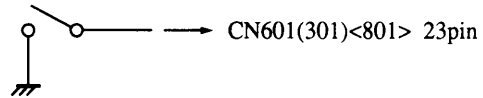

- CN601(301)<801> 15pin BRT. S. P

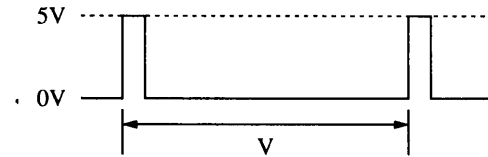

- CN601(301)<801> 16pin BPCP

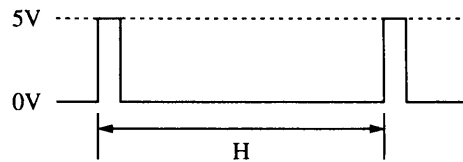

- CN601(301)<801> 17pin SW. P

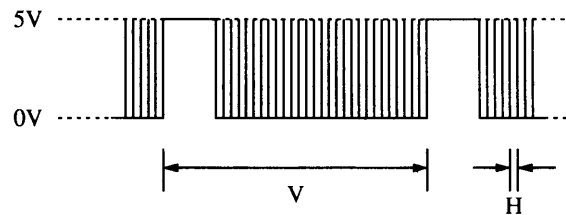

- CN601(301)<801> 18pin CONT. P

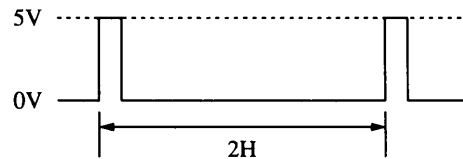

- CN601(301)<801> 19pin CONT. S. P

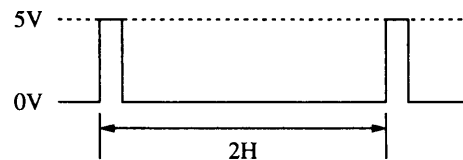

- CN601(301)<801> 20pin BKG. P

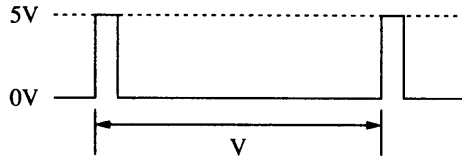

- CN601(301)<801> 21pin PED. CL. P

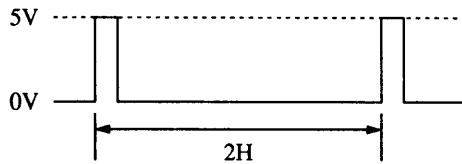

- CN601(301)<801> 23pin BLK

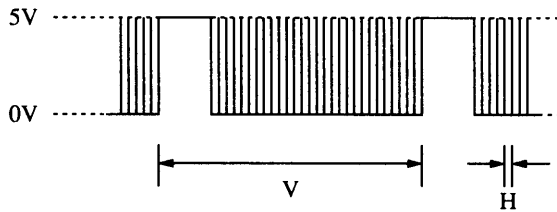

4. Input the video signal to the CAGJ1 (CARJ1) <CABJ1>.

The video 10-step stair step signal (Amplitude) is shown below.

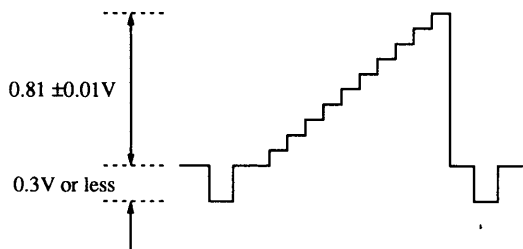

5-1-2. Single Tube I_k PROT Adjustment

1. Supply only +9 V and ±12 V. Disconnect the +103 V and -160 V power supplies.
2. Connect a 3 mA +0 / -0.1 mA current source and GND as shown below.

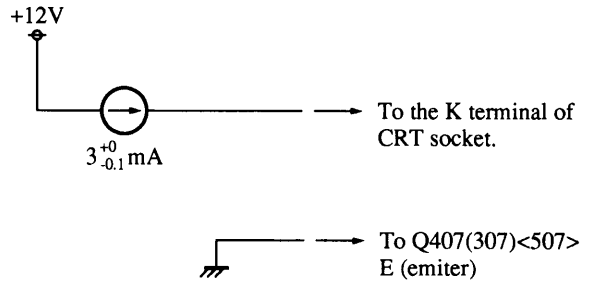

3. Adjust RV401 (301) <501> until the I_k DET (CN450 (440) <460> :12 pin) becomes 4.4 V +0.1 / -0 V.
4. Connect the +103 V and -160 V power supplies which were disconnected in step 1.
5. Remove the current source and GND which were connected in step 2.

5-1-3. SUB GAIN Adjustment

1. Set the CONTRAST and DRV to the MAX. position.

* Set the CONTRAST input volume control to -2.5 V.
Set the DRV input volume control to +2.5 V.

2. Confirm that waveform appears at the K terminal of the CRT socket using an oscilloscope.
3. While confirming the waveform at the K terminal of the CRT socket, adjust RV601 (101) <801> on the CAG board using an oscilloscope so that the waveform is just about to be compressed. (Note: Refer to the next page for details.)
4. Observe the waveform at the G1 terminal of the CRT socket and confirm that the waveform is not compressed. If the waveform is compressed, adjust the RV601 again so that the waveform is not compressed.
5. Return the CONTRAST and DRV controls to their initial settings.

Observe in H rate.

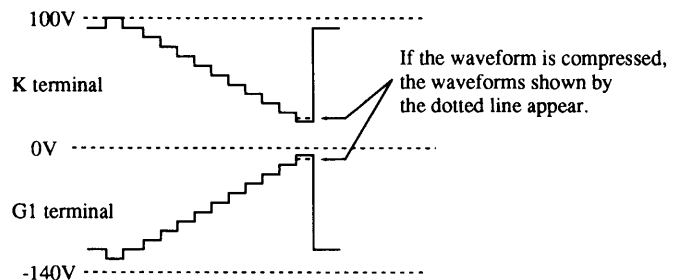

Description on Waveform Compression

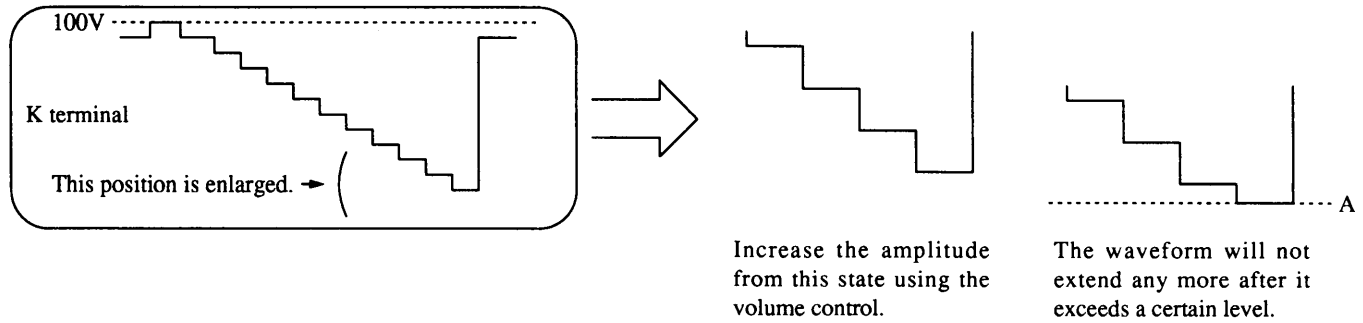

Turn the volume control to increase the amplitude. If the waveform amplitude exceeds a certain level, it will not increase any more. (Point A in the illustration.) Adjust the volume control so that the tip of the signal reaches this level, and the signal amplitude at each step is the same.

(example)

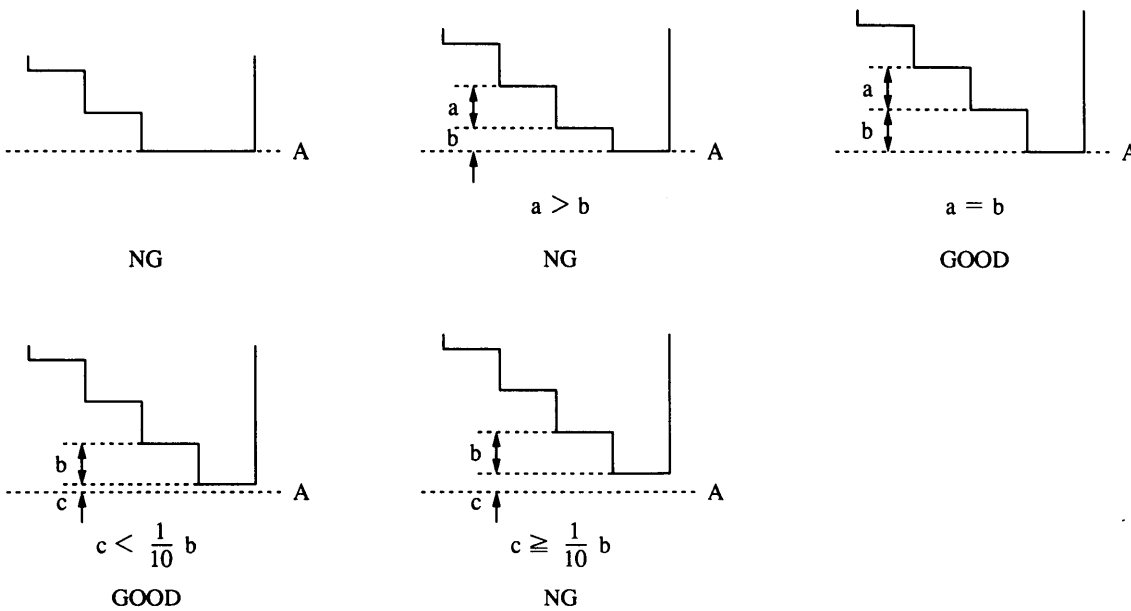

The details of compression of the signal at the G1 terminal are the same except that the waveform polarity is inverted.

(reference: It is easy to check whether a waveform is compressed or not by changing CONTRAST. Don't forget to return CONTRAST to MAX. after checking.)

5-2. DA BOARD ADJUSTMENT

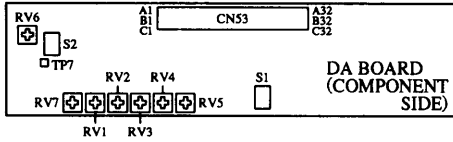

- S1 : V. SYNC OFF
- S2 : HD OFF
- RV1 : AFC
- RV2 : F-V
- RV3 : VIDEO AFC
- RV4 : V. HOLD
- RV5 : SHIFT
- RV6 : FH-LIMIT
- RV7 : HI-AFC
- TP7 : F-V

5-2-1. Power Line Connection

- ① 1-a, b, c : +5.7V
- ② 2-a, b, c : -5.7V
- ③ 4-b, c : +15V
- ④ 5-a, b, c : -15V
- ⑤ 6-a, b, c }
18-a, b, c } : GND
23-a, b, c }
- ⑥ 4-a : +B. JANG

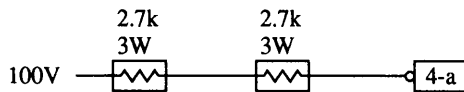

5-2-2. Connecting the Signals

- ① 8-a: H. SYNC width 1.5 μ seconds
* 5 Vp-p, negative 15 kHz to 135 kHz or 155 kHz

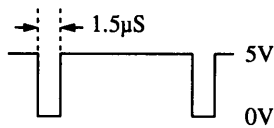

- ② 9-a: V. SYNC width 33 μ seconds
* 5 Vp-p, negative 38 Hz to 150 Hz variable

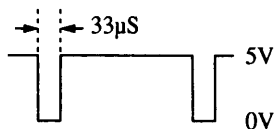

- ③ 7-b: H. D.

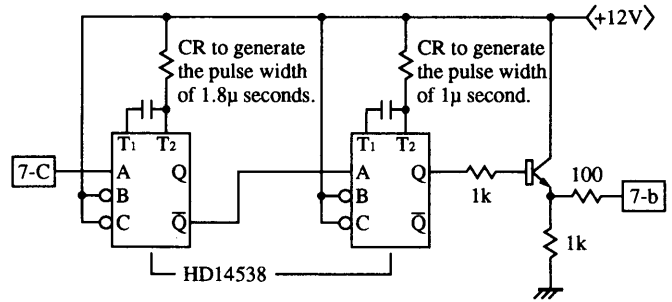

- ④ 7-a (SIZE LIMIT)
- 11-c (H. SIZE)
- 26-a (V. SIZE)
- 25-b (BLK-L)
- 25-c (BLK-R)
- 26-b (BLK-B)
- 26-c (BLK-T)
- 17-b (H. SHIFT)
- 27-c (V. SHIFT)

* These signals are low impedance output with a variable range of ± 2.5 V.

(example)

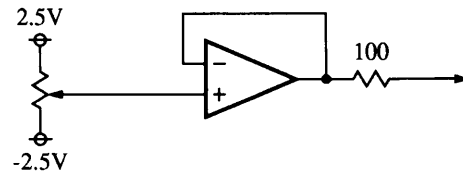

- ⑤ DVS/NVS switch

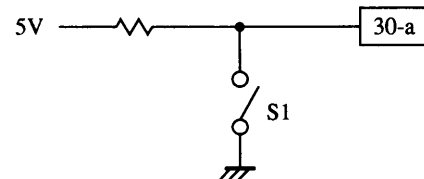

- ⑥ 27-a
28-a
29-a

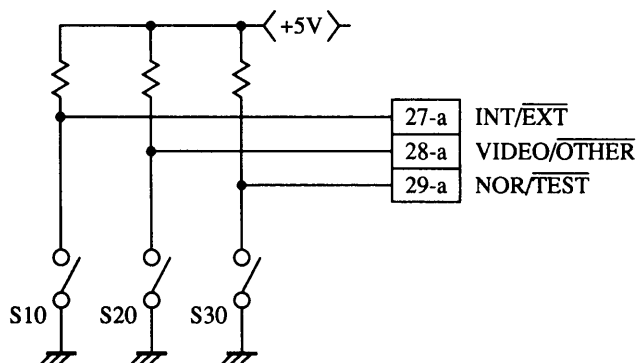

5-2-3. RGB AFC Adjustment

1. Set the switches S10 and S20 to ON, and S30 to OFF on the tool.

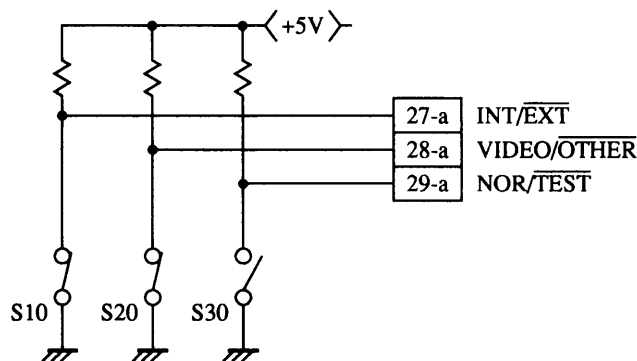

2. Set the H. SYNC to $f_H = 33.75$ kHz.
3. Set the switch S2 on the DA board to OFF. Adjust RV2 until F-V voltage (TP-2) is 2.25 V.

* Specification: 2.25 ± 0.05 V

4. Adjust RV1 until the signal 8-a and the signal 7-b are synchronized.

5-2-4. RGB HI-AFC and FH Limiter Adjustment

1. Set the switches S10 and S20 to ON, and S30 to OFF on the tool.

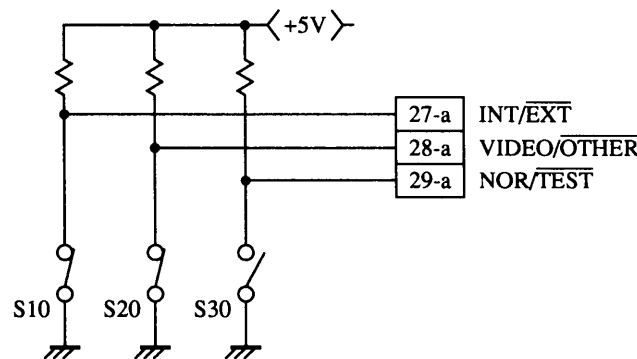

2. Turn RV6 fully counter-clockwise.
3. Set the H. SYNC to $f_H = 135.00$ kHz.
4. Set the switch S2 on the DA board to ON and adjust RV7 until the signal 8-a and the signal 7-b are synchronized.
5. Set the H. SYNC to $f_H = 155.00$ kHz.
6. Connect the signal 7-b to a frequency counter, and adjust RV6 until its frequency satisfies the specification shown.

* Specification: 145 ± 1 kHz

7. Set the switch S2 on the DA board to ON.
8. Sweep the 8-a. H. SYNC signal from 15 kHz to 135 kHz, and confirm that all points are synchronized with the 7-b signal. Set the 8-a. H. SYNC signal to 155 kHz.
9. Confirm that the 7-b signal loses synchronization and satisfies the specification shown.

* Specification: 145 to 150 kHz

10. If step 9 is not satisfied, return to section 5-2-3, step 1.

5-2-5. VIDEO AFC Adjustment

1. Set the switches S10 to ON, and S20 and S30 to OFF on the tool.

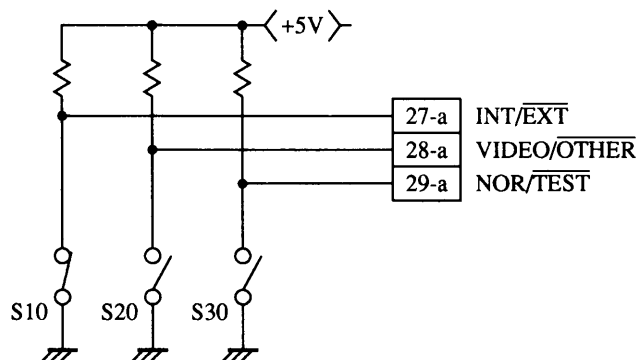

2. Set the H. SYNC to $f_H = 15.734$ kHz.
3. Set the switch S2 on the DA board to OFF and adjust RV3 until the signal 8-a and the signal 7-b are synchronized.
4. Set the switch S2 on the DA board to ON and confirm that the signal 8-a H. SYNC and the signal 7-b HD are in phase.
5. If step 4 is not satisfied, return to step 3.

5-2-6. V. HOLD Control Adjustment

1. Set switch S1 on the DA board to OFF.
2. Input the 60 Hz V. SYNC signal to 9-a.
3. Connect a frequency counter to 8-c and adjust RV4 until 36 Hz is displayed.

* Specification: 36.0 ± 0.5 Hz

4. Set switch S1 on the DA board to ON and confirm that the 8-C signal frequency is equal to the V. SYNC frequency (60 Hz) using a frequency counter.

5-3. DE BOARD ADJUSTMENT

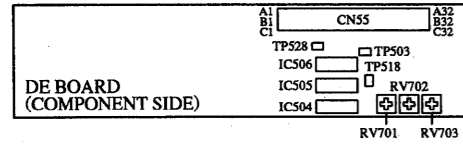

- RV701: VS1 BIAS
- RV702: VP BIAS
- RV703: VS2 BIAS
- TP503: VS1 BIAS
- TP518: VP BIAS
- TP528: VS2 BIAS

5-3-1. Power Line Connection

- ① 1-a, b : +5.7V
- ② 2-a, b : -5.7V
- ③ 1-c : +8V
- ④ 2-c : -8V
- ⑤ 3-a, b, c }
6-a, b, c } : GND
9-a, b, c }
18-a, b, c }

5-3-2. Signal Connections

- ① 19-a, b, c (H. PARA)
- 20-a, b, c (H. SIN1)
- 21-a, b, c (H. SIN2)
- 22-a, b, c (V. PARA)
- 23-a, b, c (V. SIN1)
- 24-a, b, c (V. SIN2)
- 26-a (1/2 H)
- 32-b (1/2 V)

* Supply all signals from the DA board being used.

- ② 31-c (MG. HD)
- 32-c (MG. VD)

* Supply the HD and VD signals from the DA board which is being used.

- ③ 4-a, b, c (H. SIZE)
- 25-a, b, c (V. SIZE)

* These signals must be low impedance output with a variable range of ± 2.5 V.

(example)

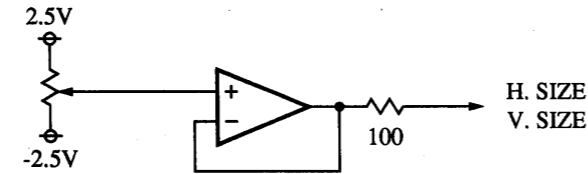

- ④ 28-c ($\overline{A6}$)
- 30-a (SD)
- 31-a (LD)
- 32-a (CLK)

* Supply all signals from the DB board which is being used.

- ⑤ 27-a (A7)
- 27-b (A6)
- 27-c (A5)
- 28-a (A4)
- 28-b (A3)

* Supply these signals from the tool which feeds signals to the DB board.

- ⑥ 26-c (\overline{WR})

* Supply these signals from the tool which feeds signals to the DB board.

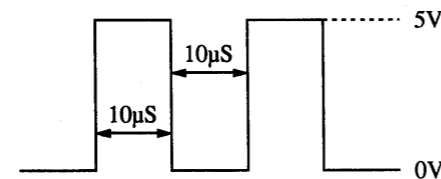

⑦ Tool connection diagram

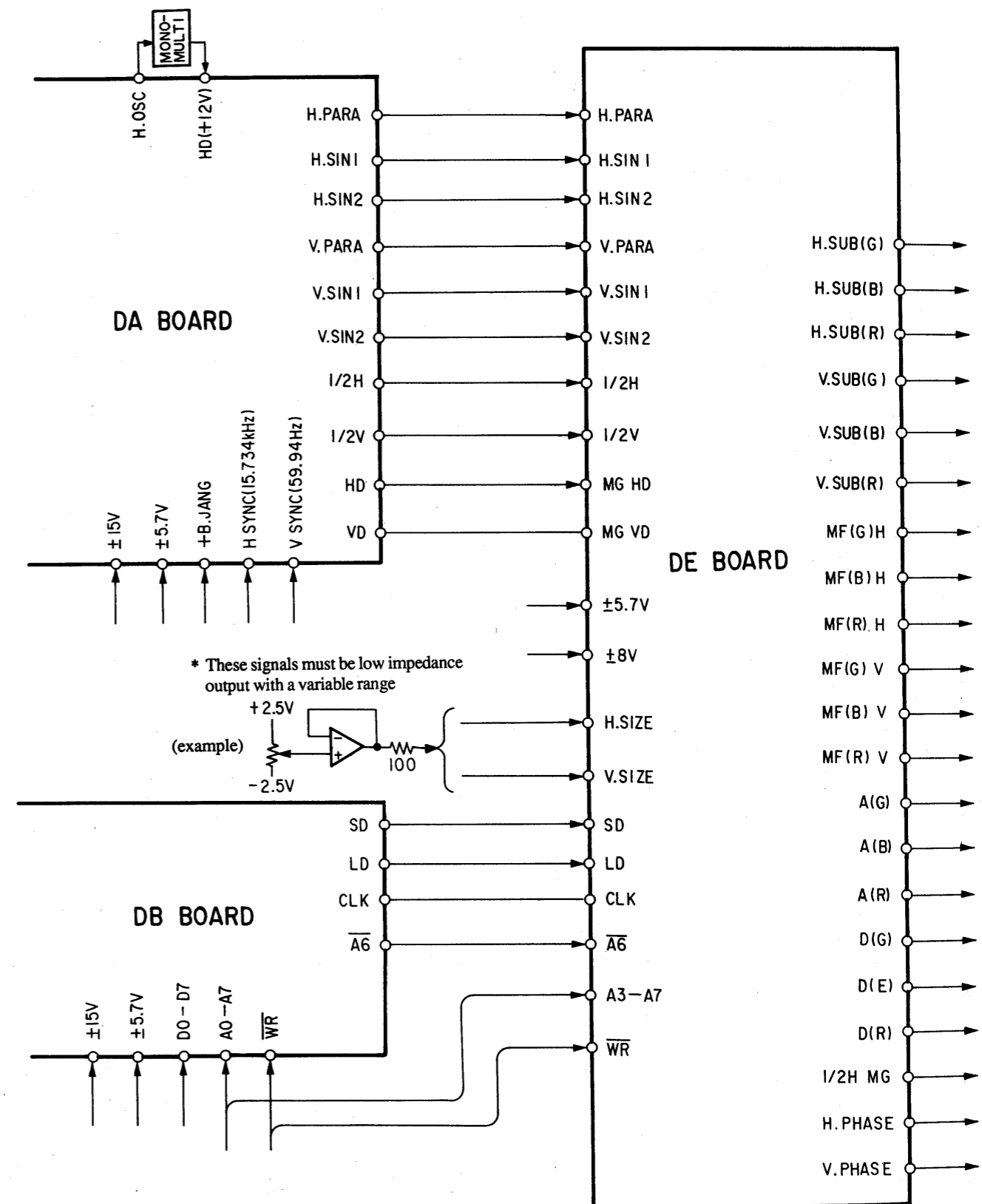

**SECTION 6
DIAGRAMS**

5-3-3. Offset Adjustment of Standard Waveform of Registration Correction

1. V. PARA Offset Adjustment

Observe 22-a, b, c (TP518) with an oscilloscope and adjust RV702 until the specification shown on the right is satisfied.

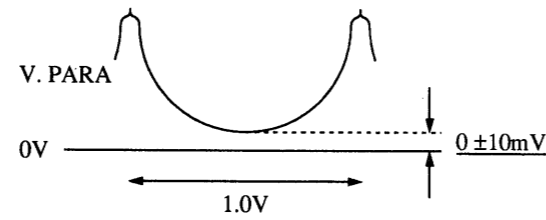

2. V. SIN 1 Offset Adjustment

Observe 23-a, b, c (TP503) with an oscilloscope and adjust RV701 until the specification shown in the right is satisfied.

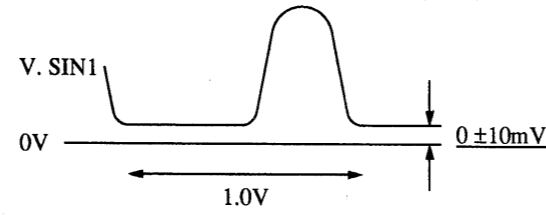

3. V. SIN 2 Offset Adjustment

Observe 24-a, b, c (TP528) with an oscilloscope and adjust RV703 until the specification shown in the right is satisfied.

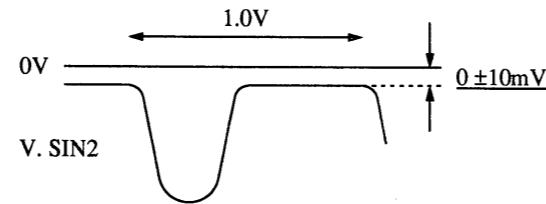

6-1. CIRCUIT BOARDS LOCATION

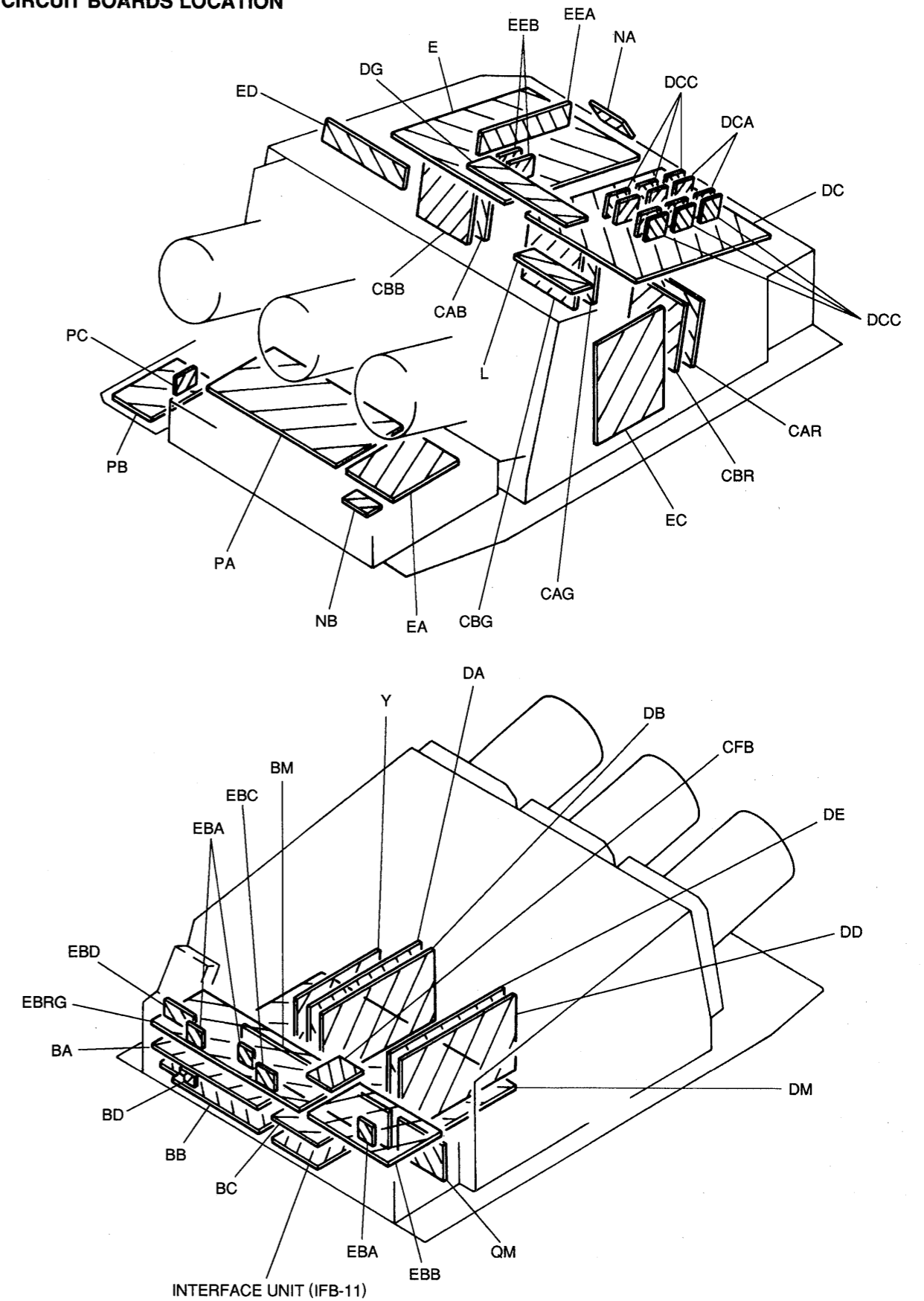

6-2. BLOCK DIAGRAMS

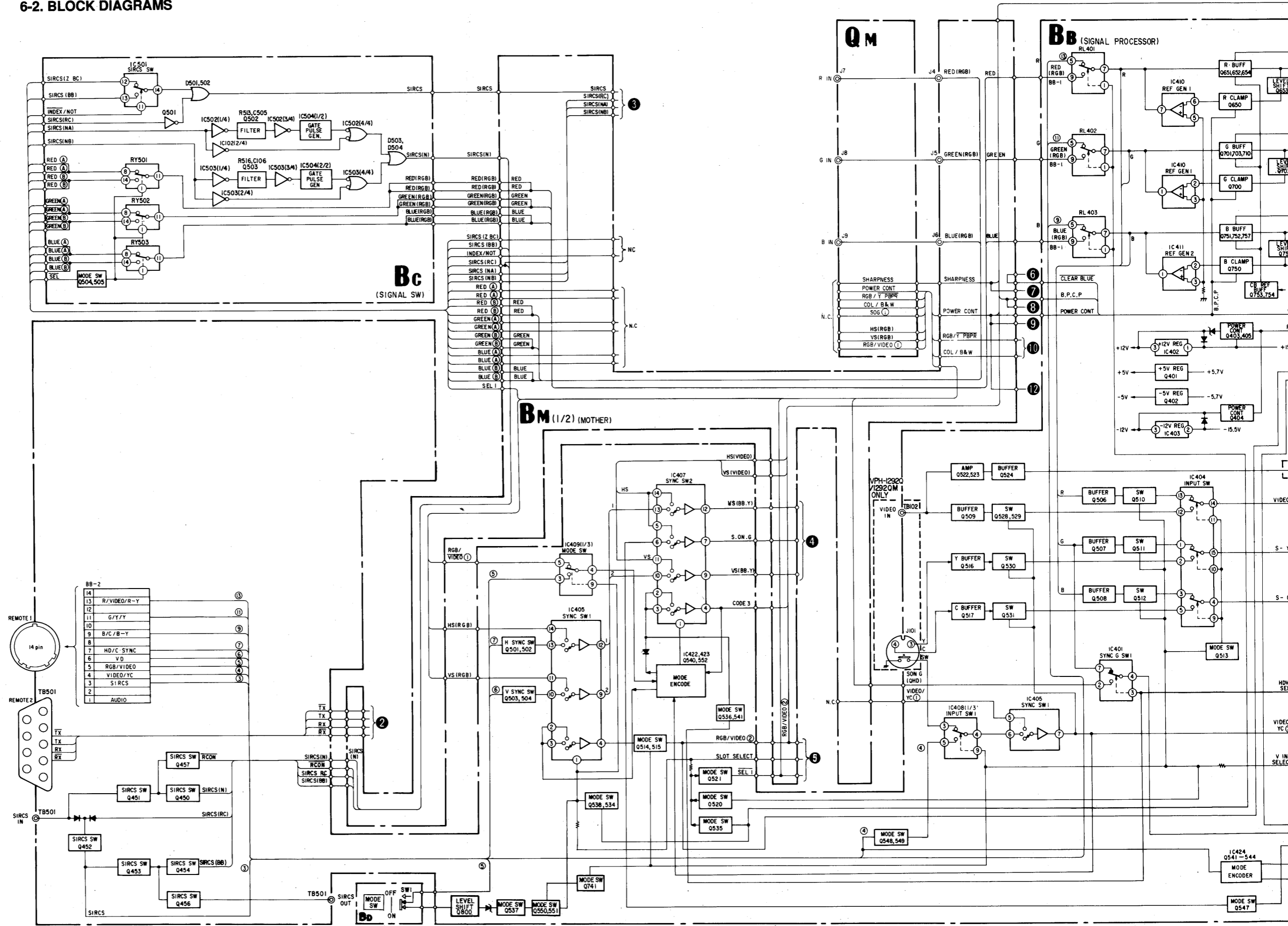

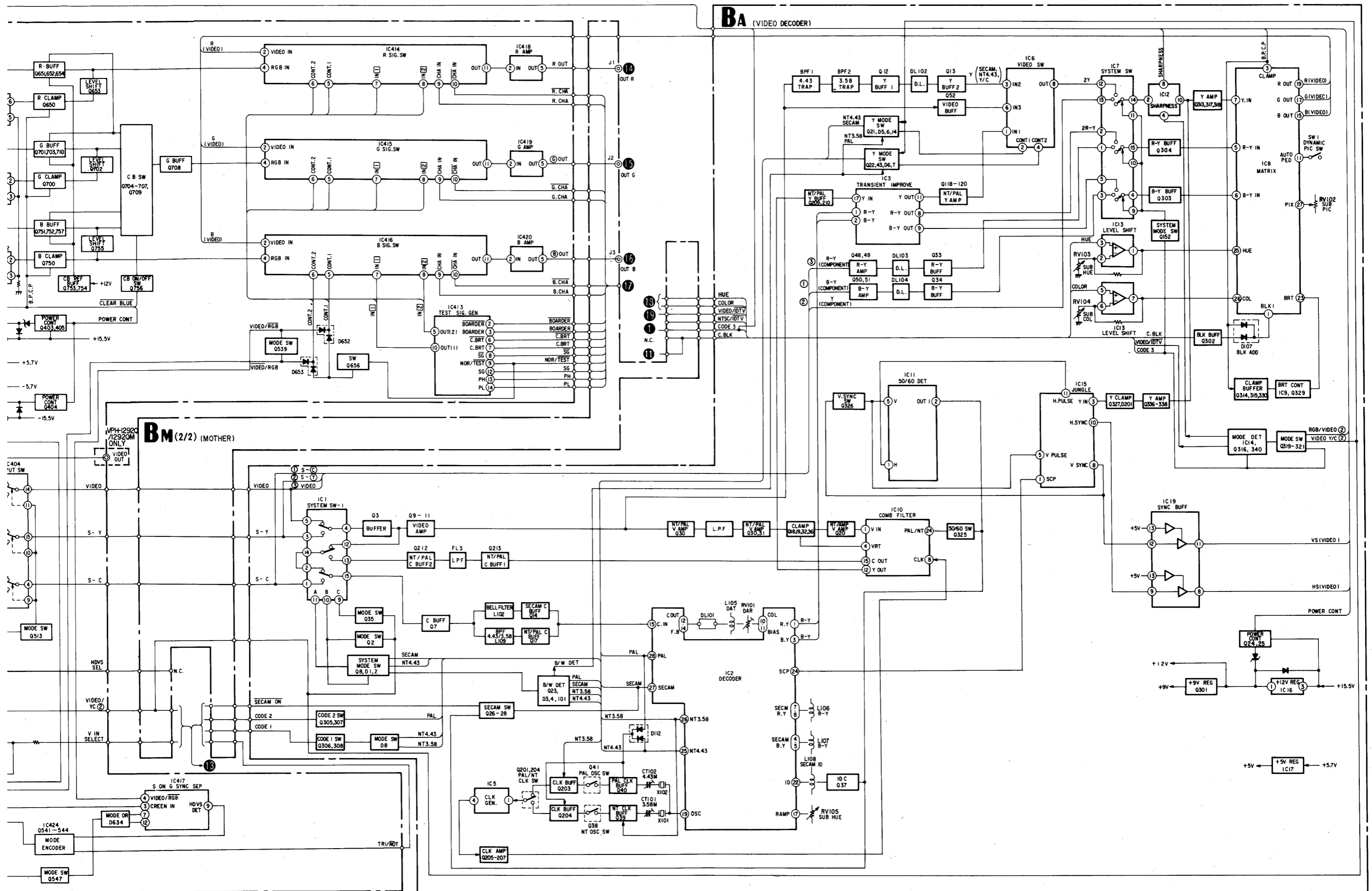

A1

BLOCK DIAGRAMS

BLOCK DIAGRAMS

The following diagram has been divided into 3 sections as noted on the grid shown below.

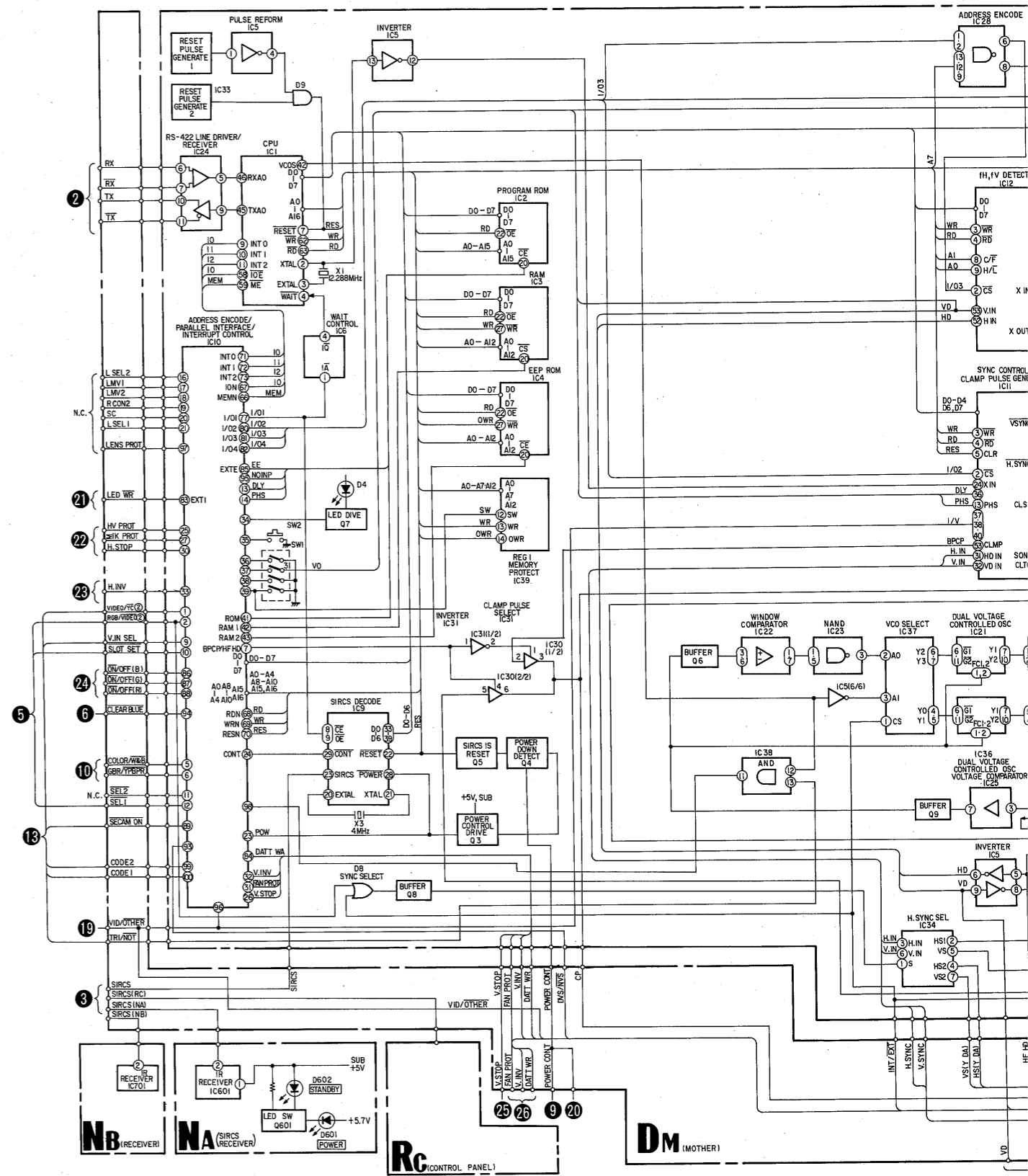
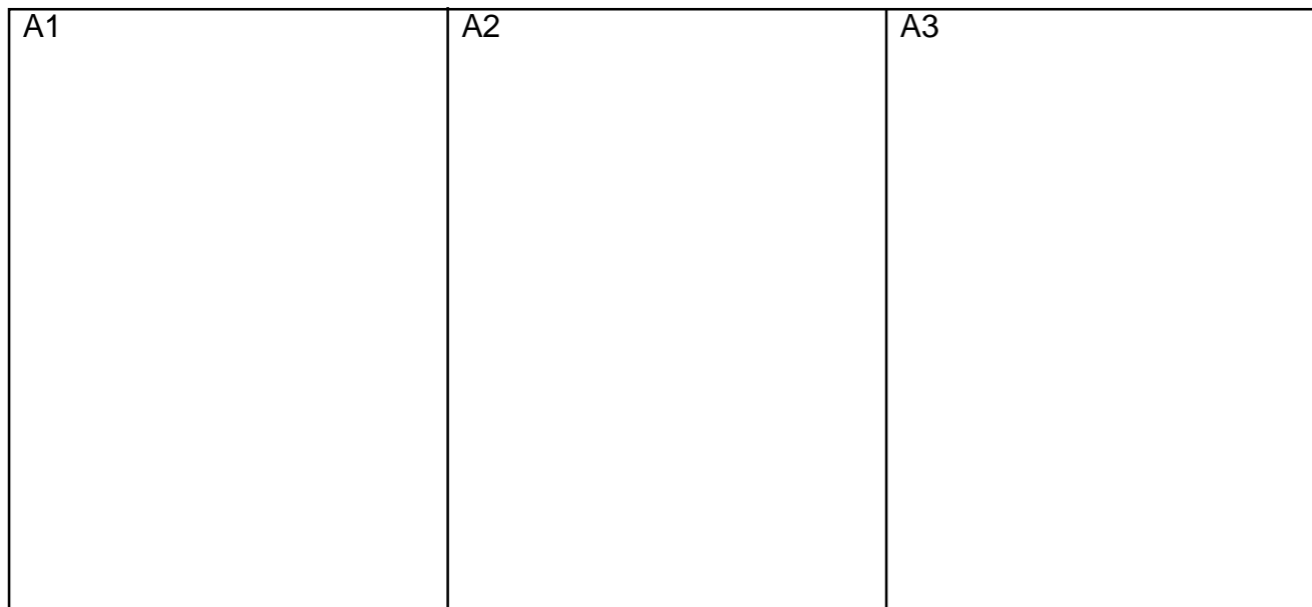

A2

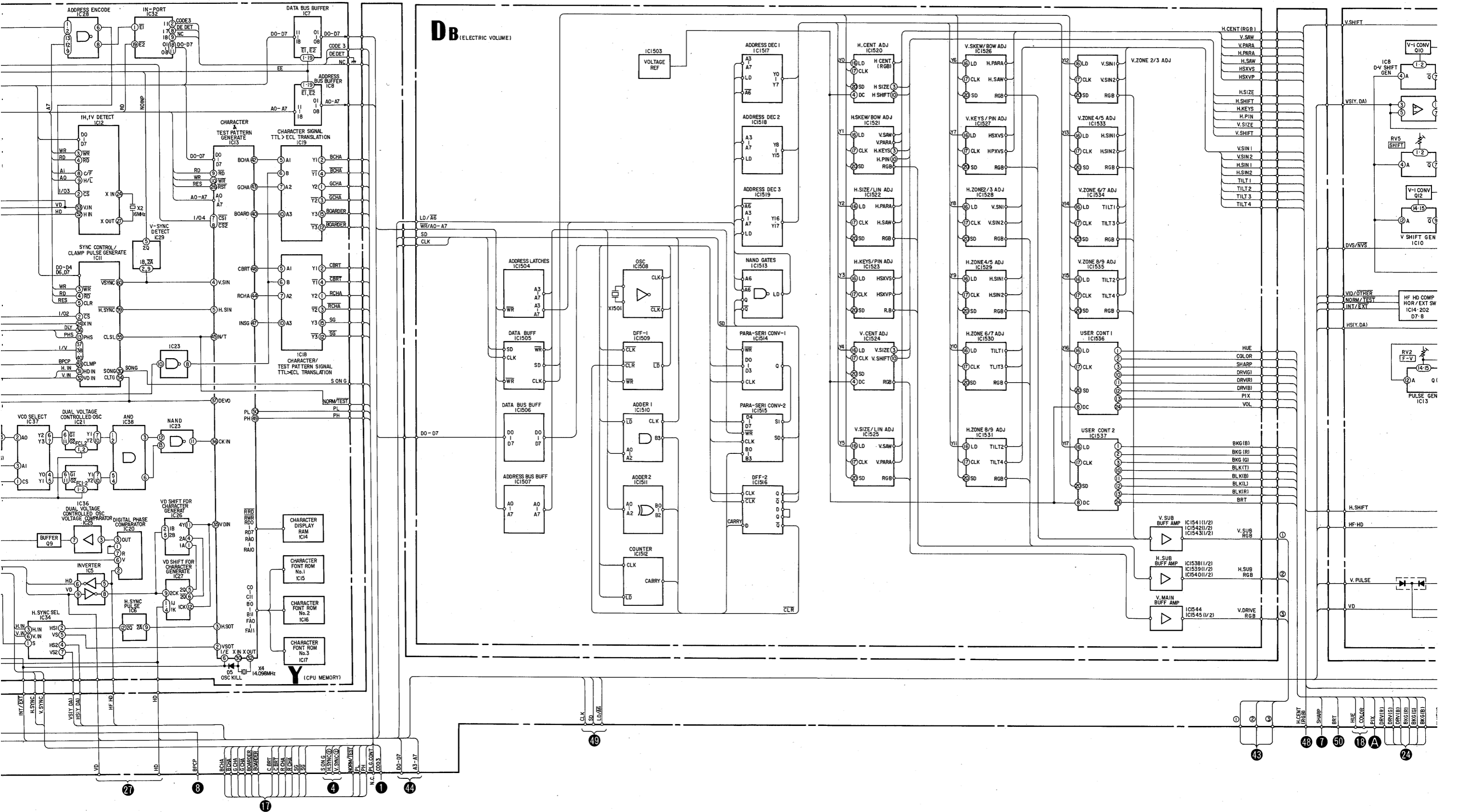

A3

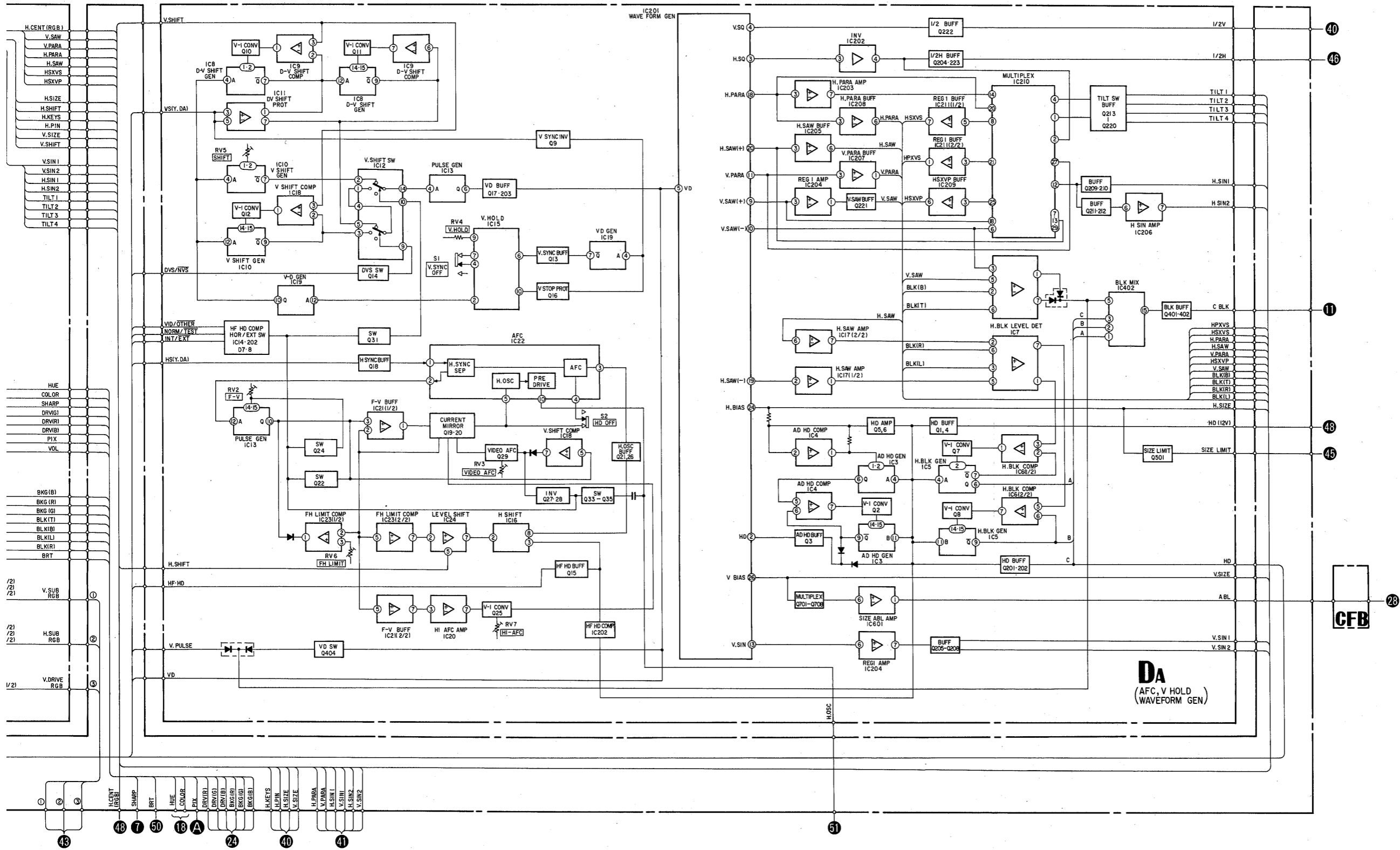

A1

BLOCK DIAGRAMS

BLOCK DIAGRAMS

The following diagram has been divided into 3 sections as noted on the grid shown below.

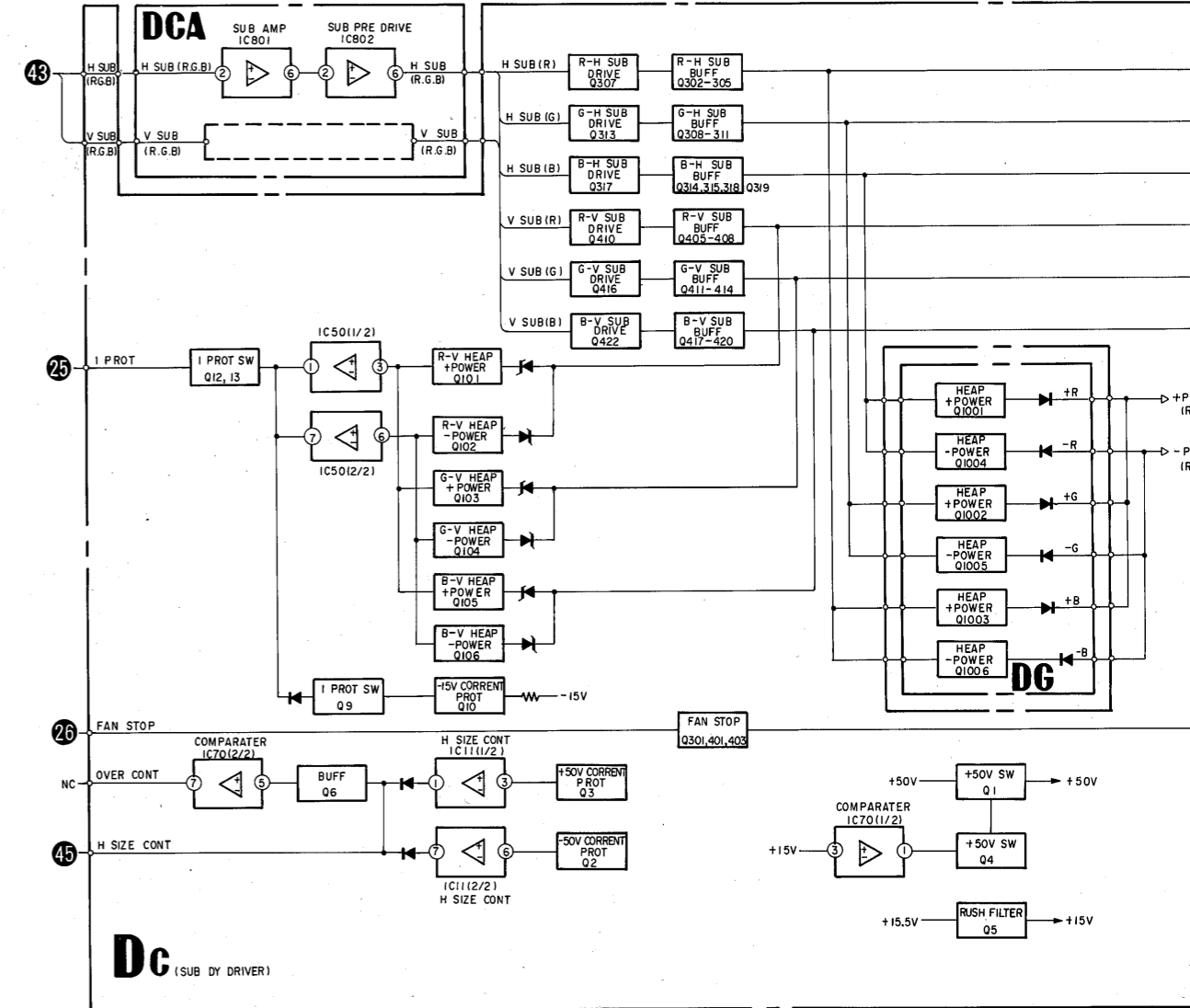
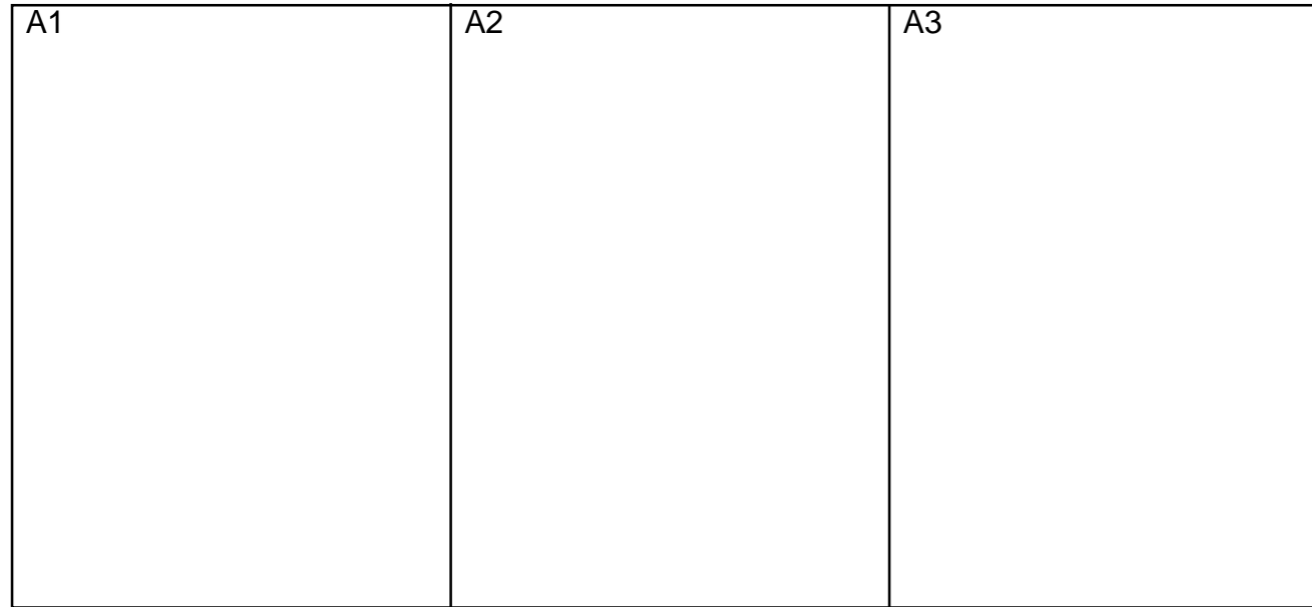

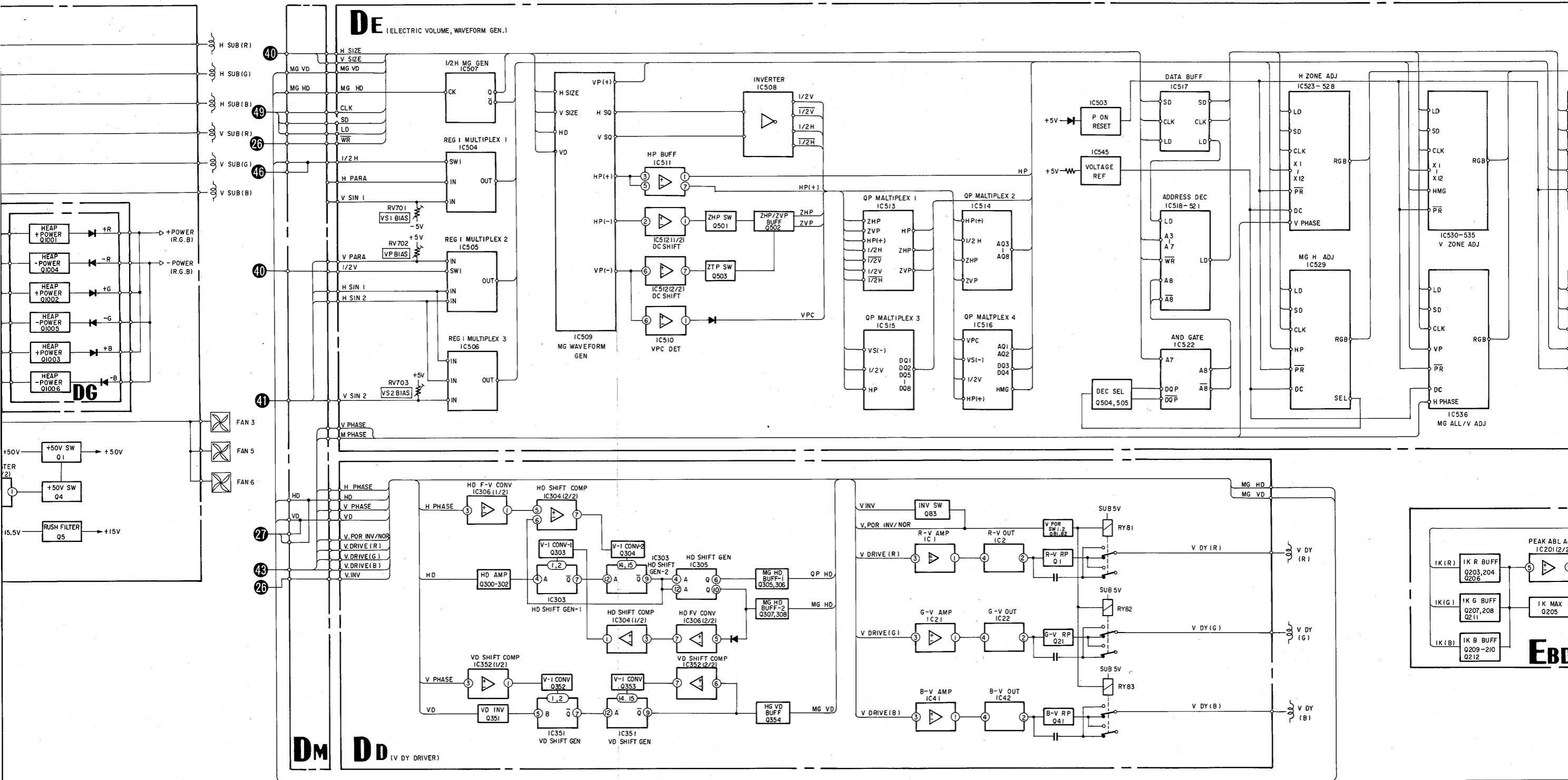

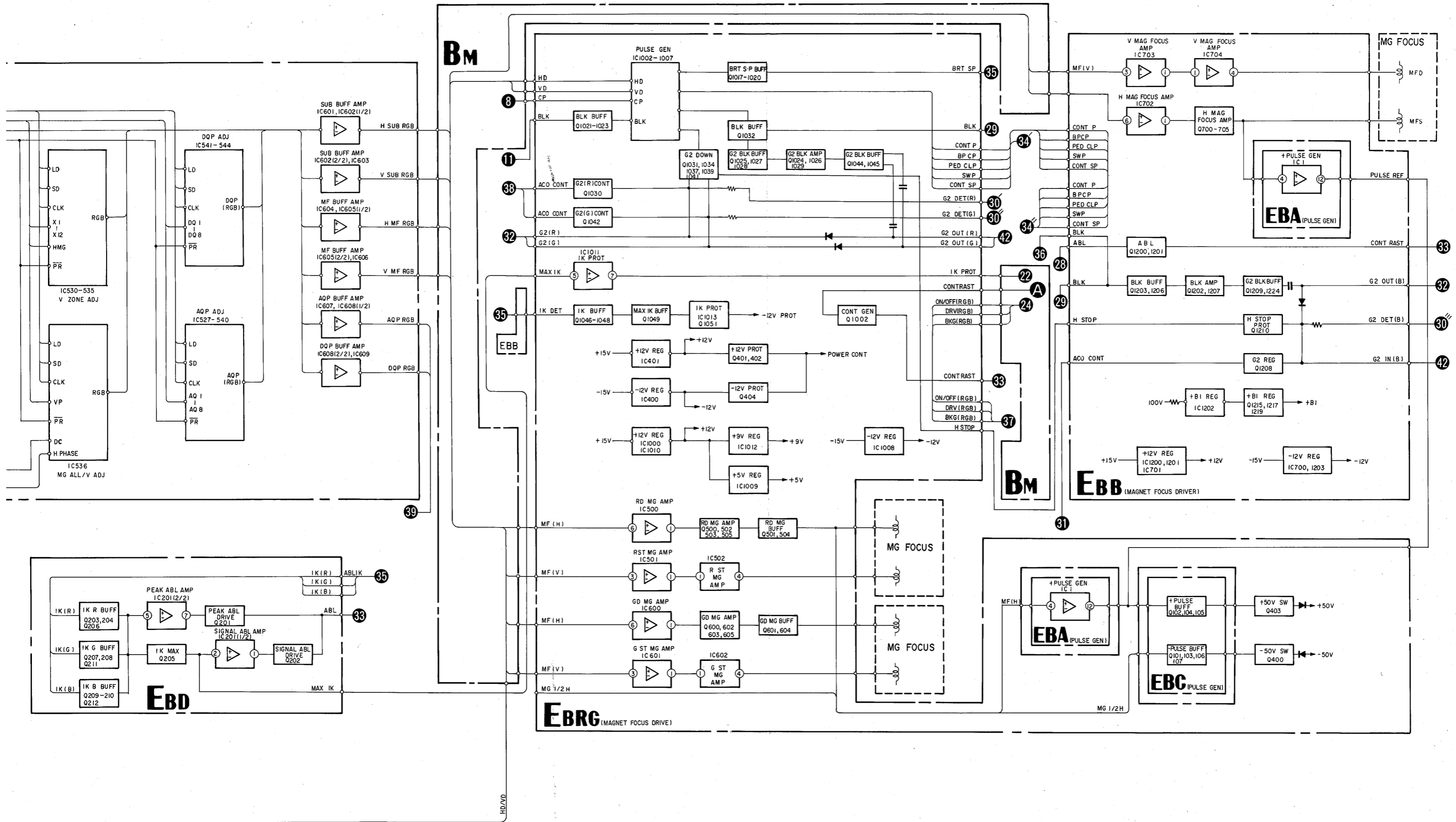

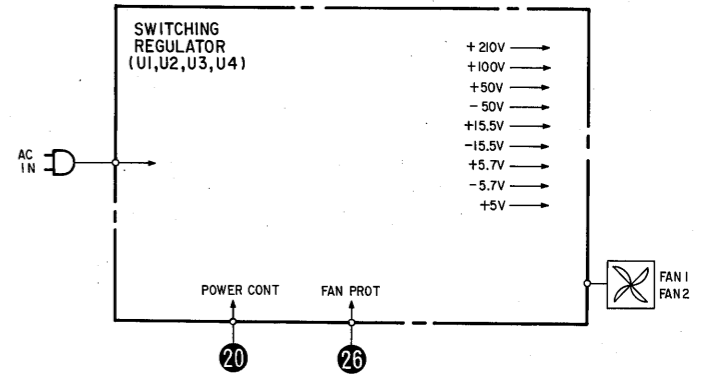
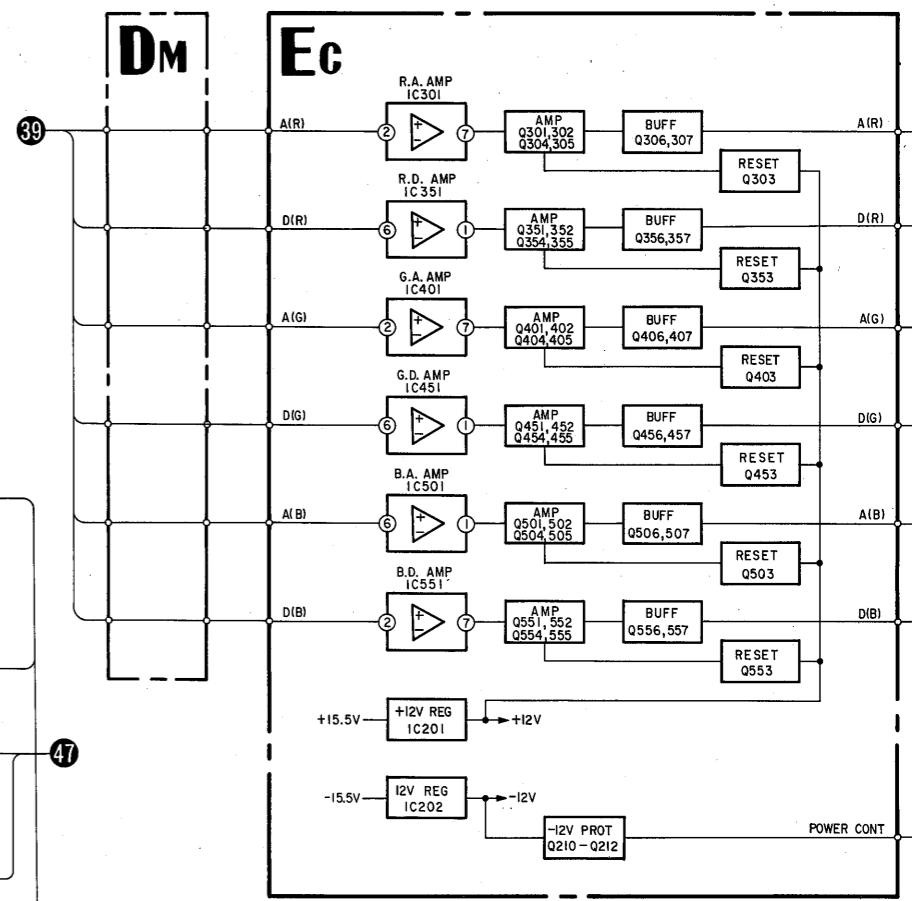
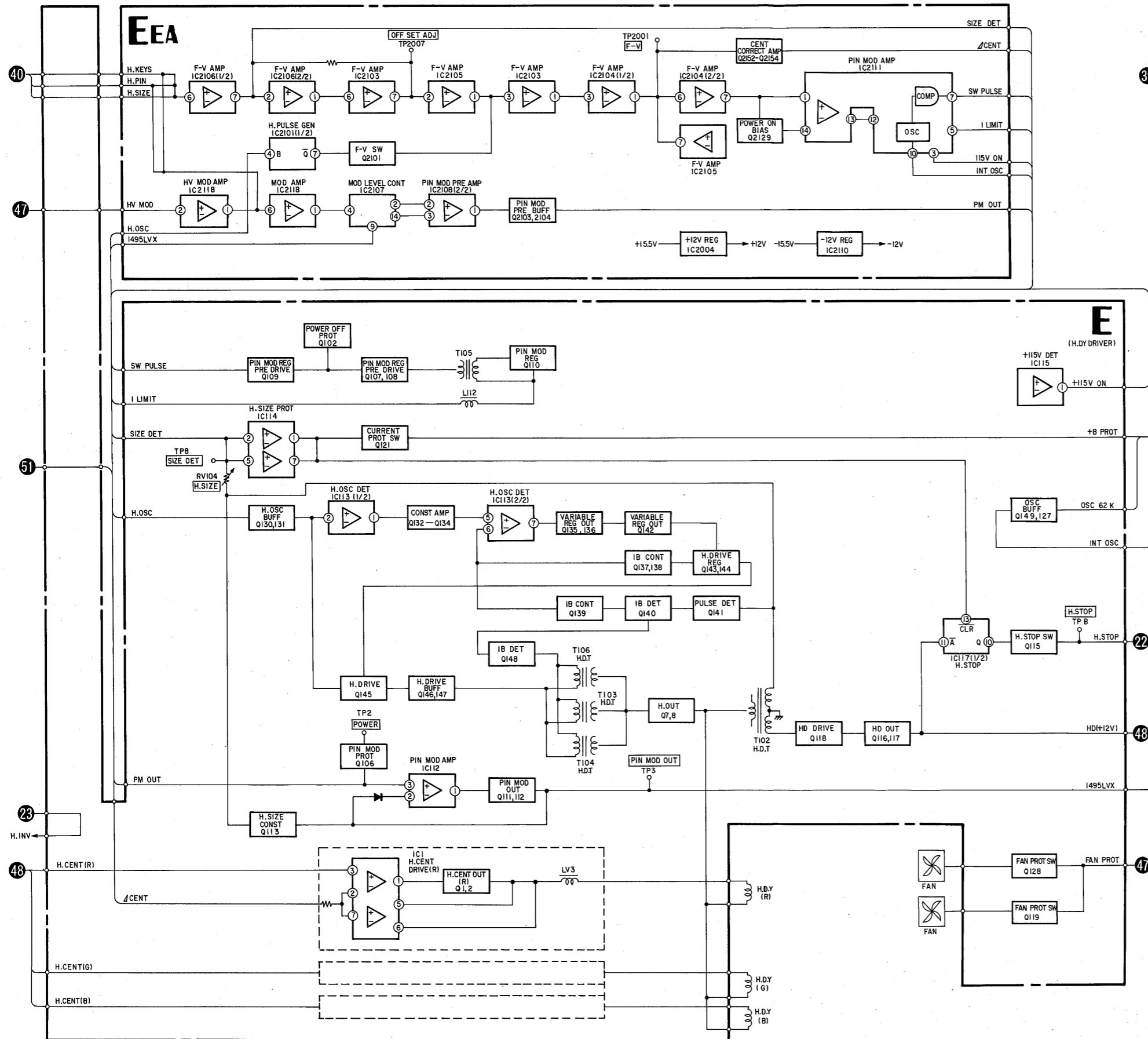

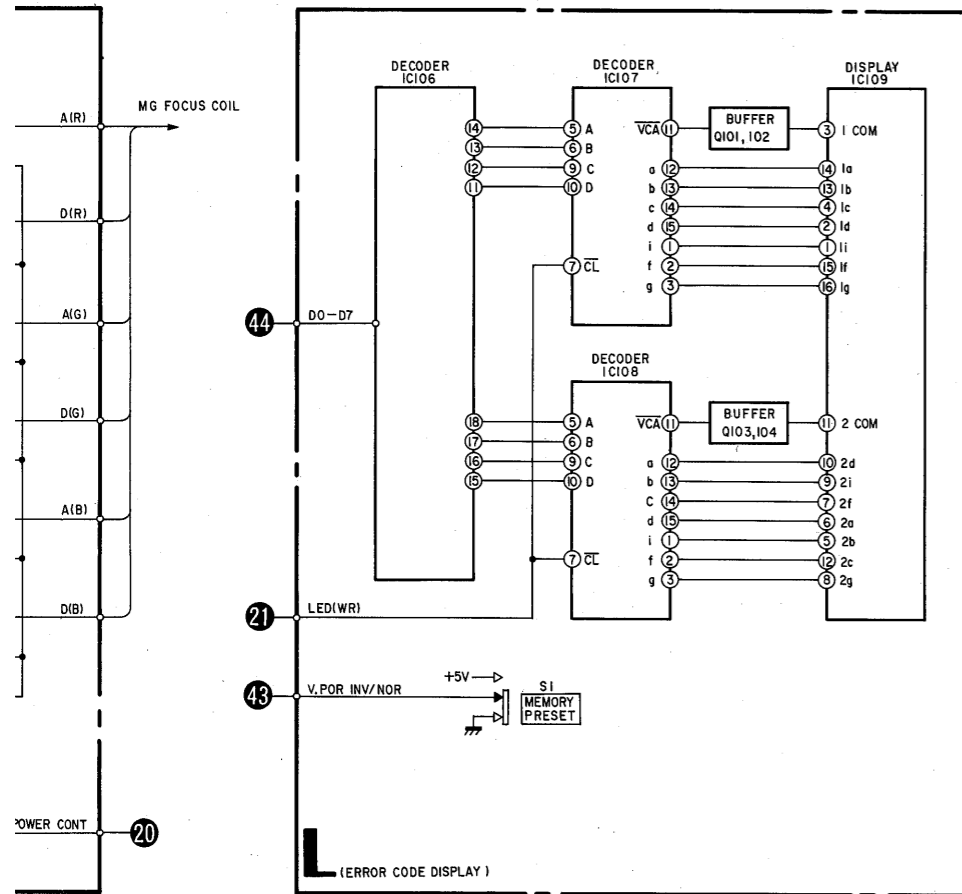

FAN 1
FAN 2

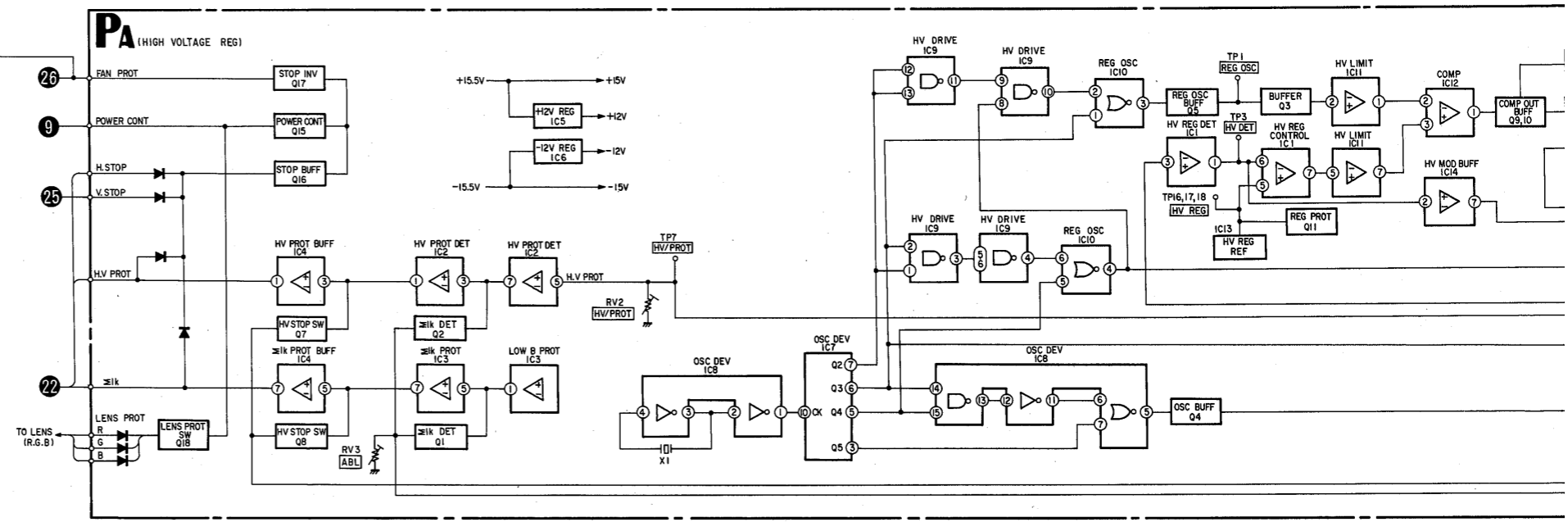
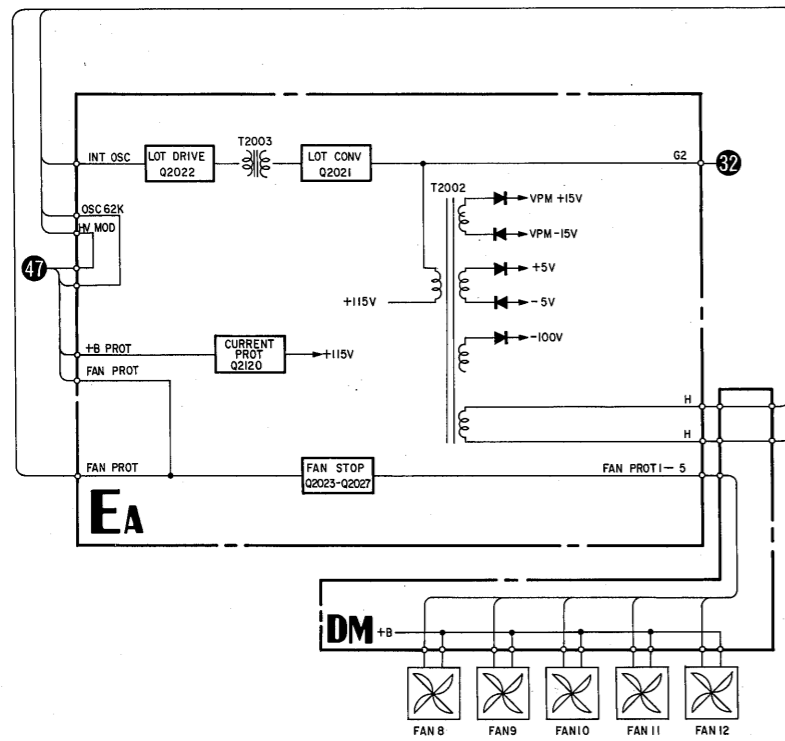
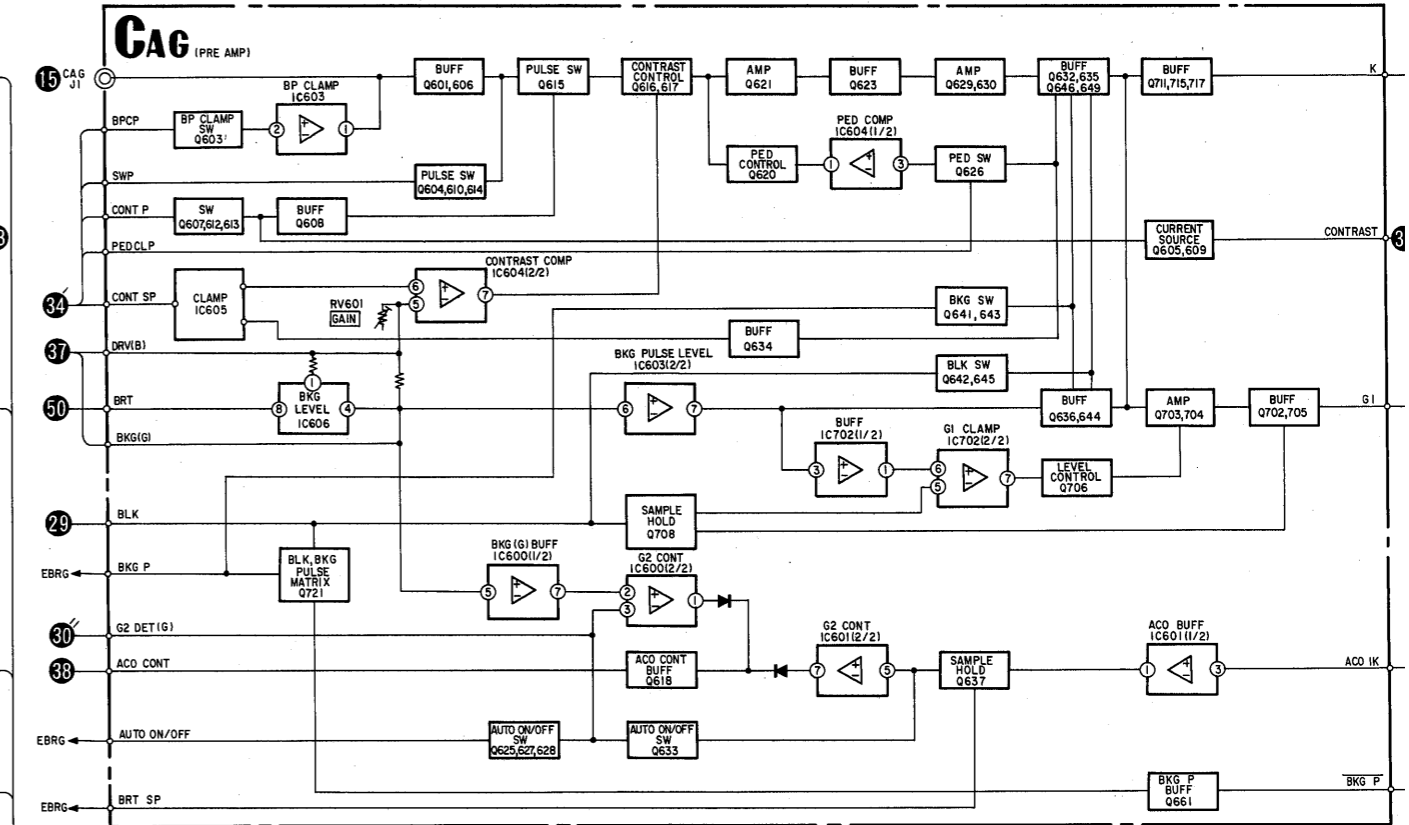
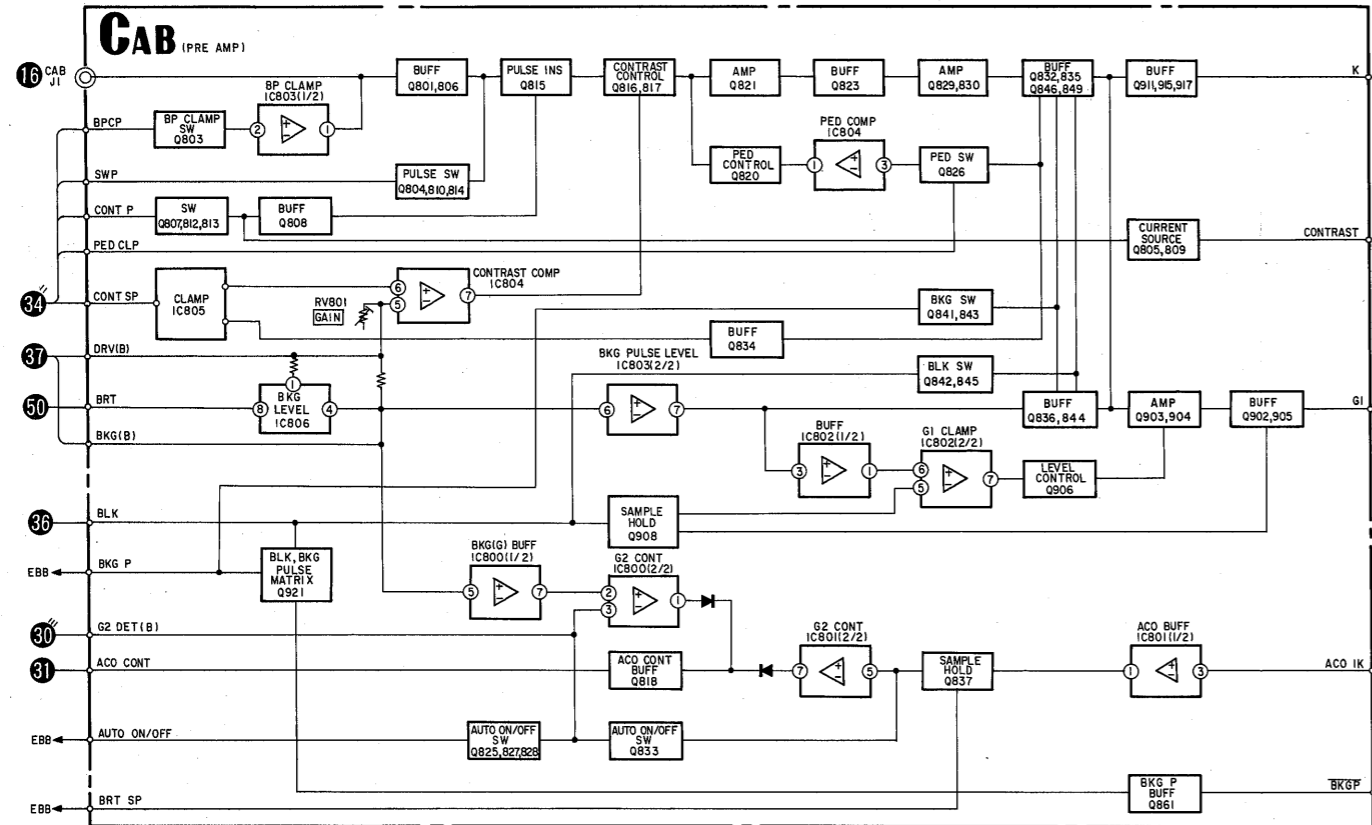

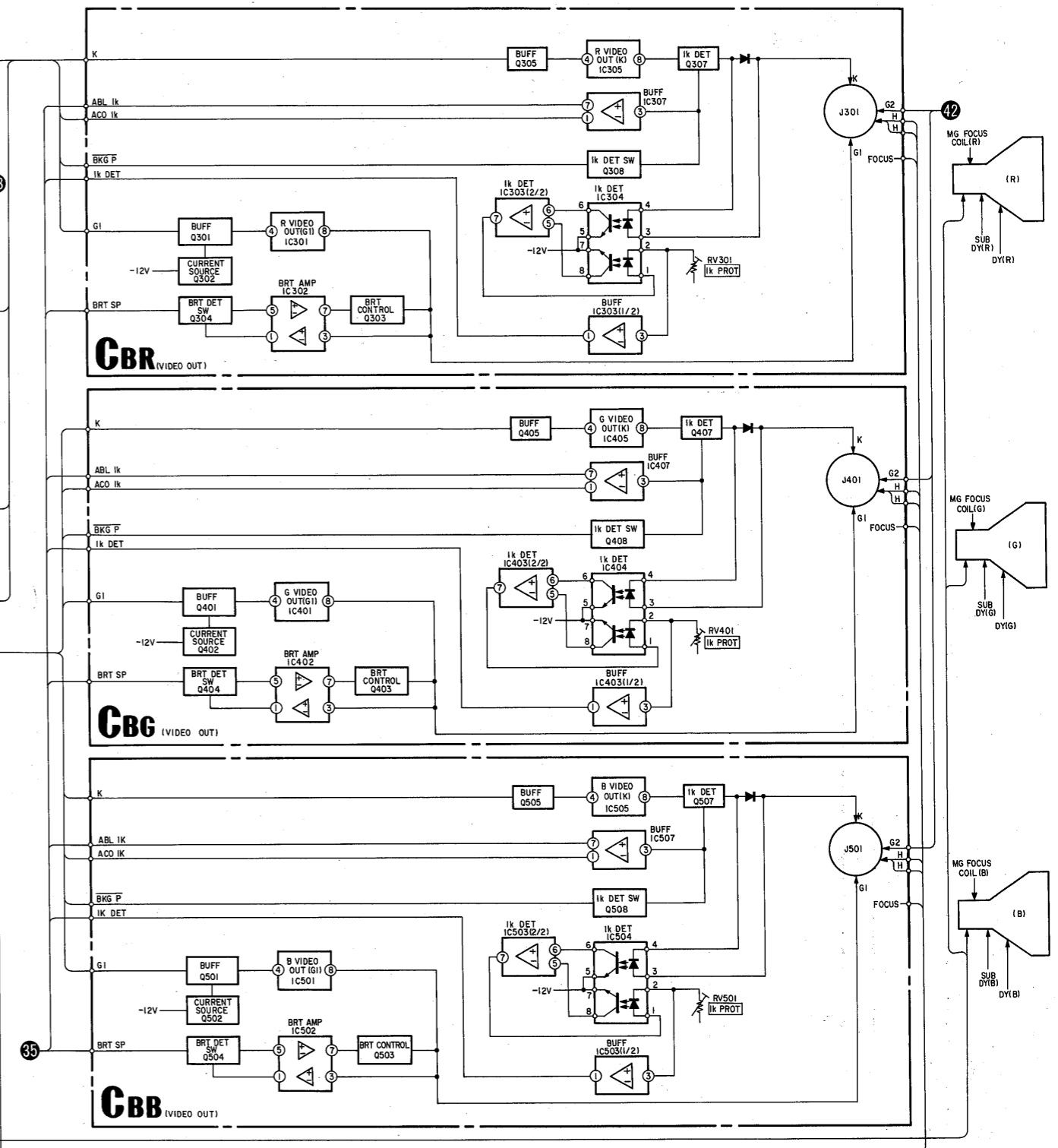
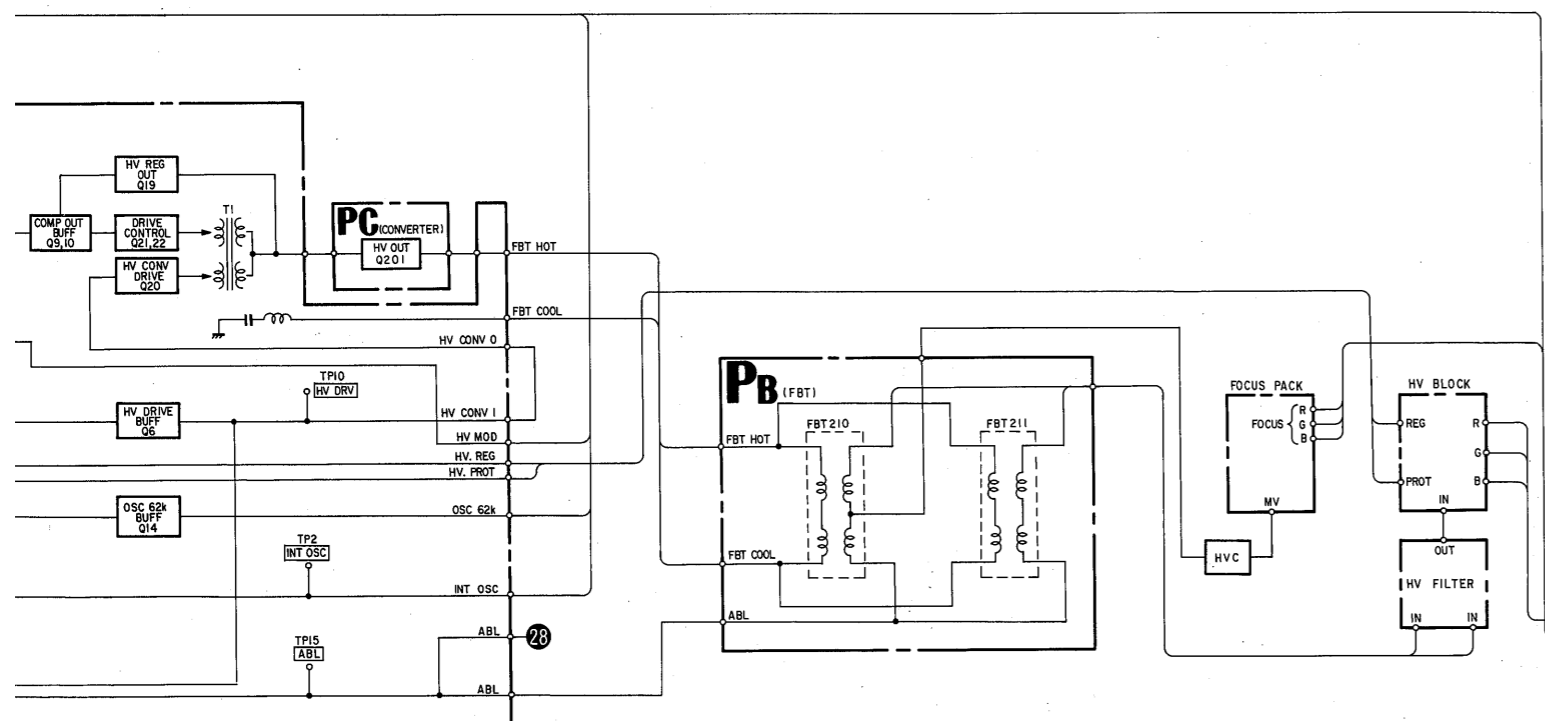
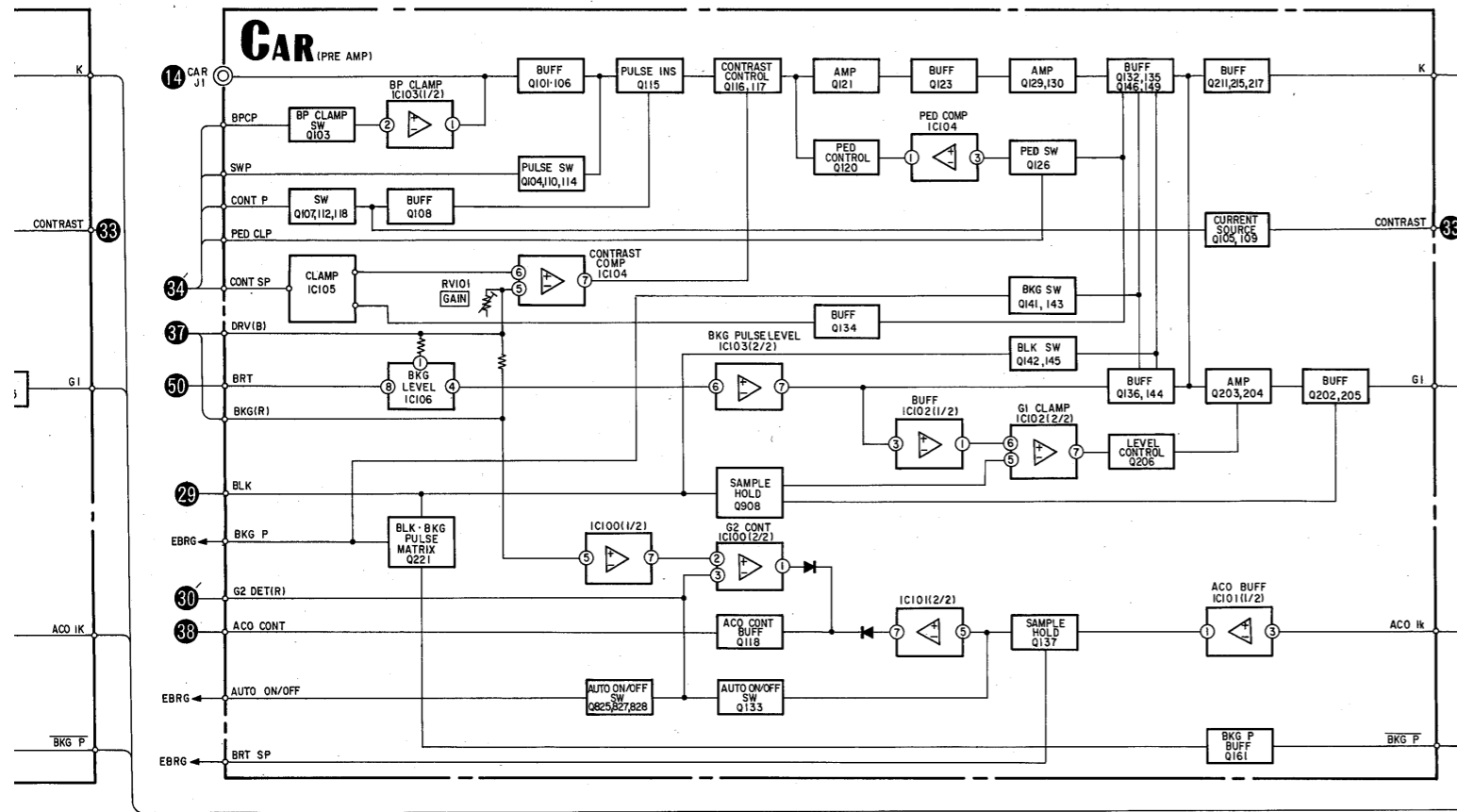

FRAME SCHEMATIC DIAGRAMS

FRAME SCHEMATIC DIAGRAMS

The following diagram has been divided into 3 sections as noted on the grid shown below.

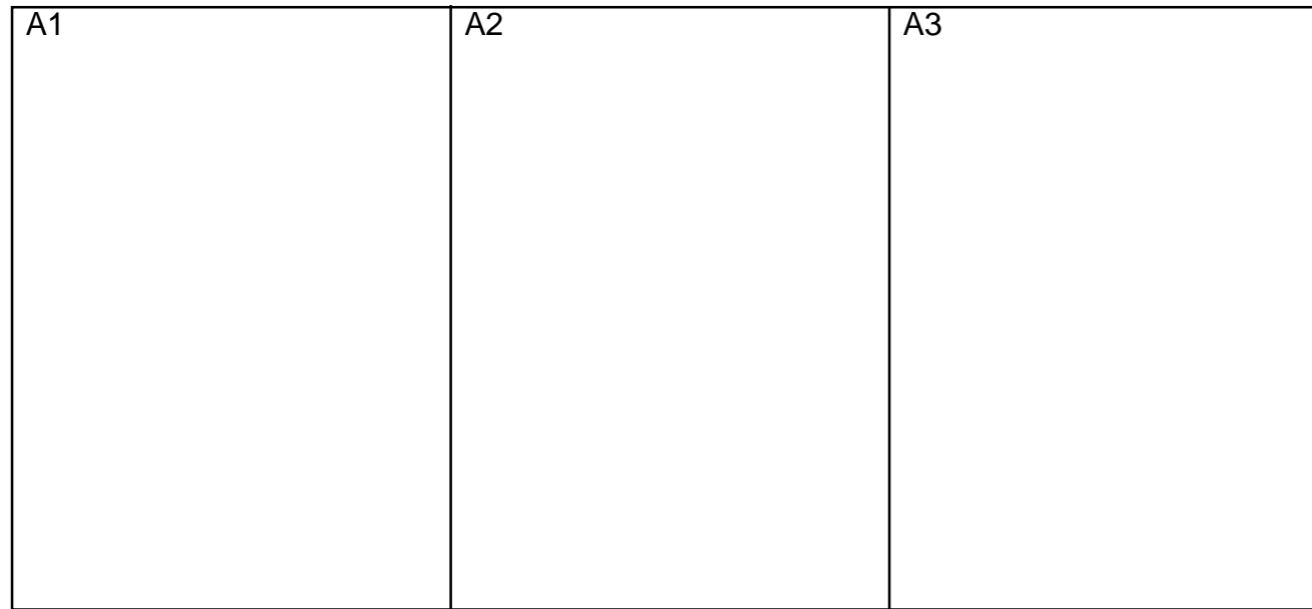

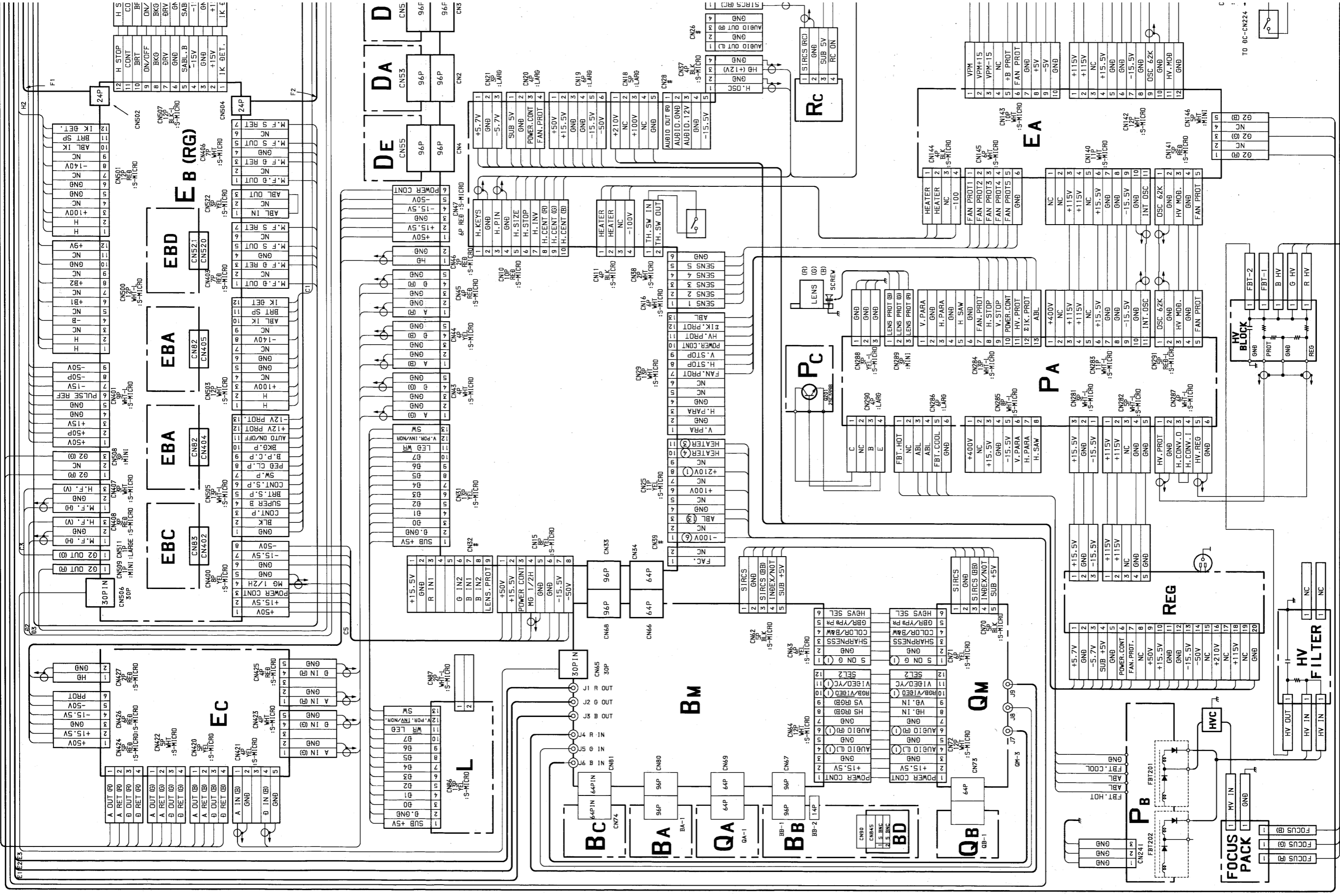

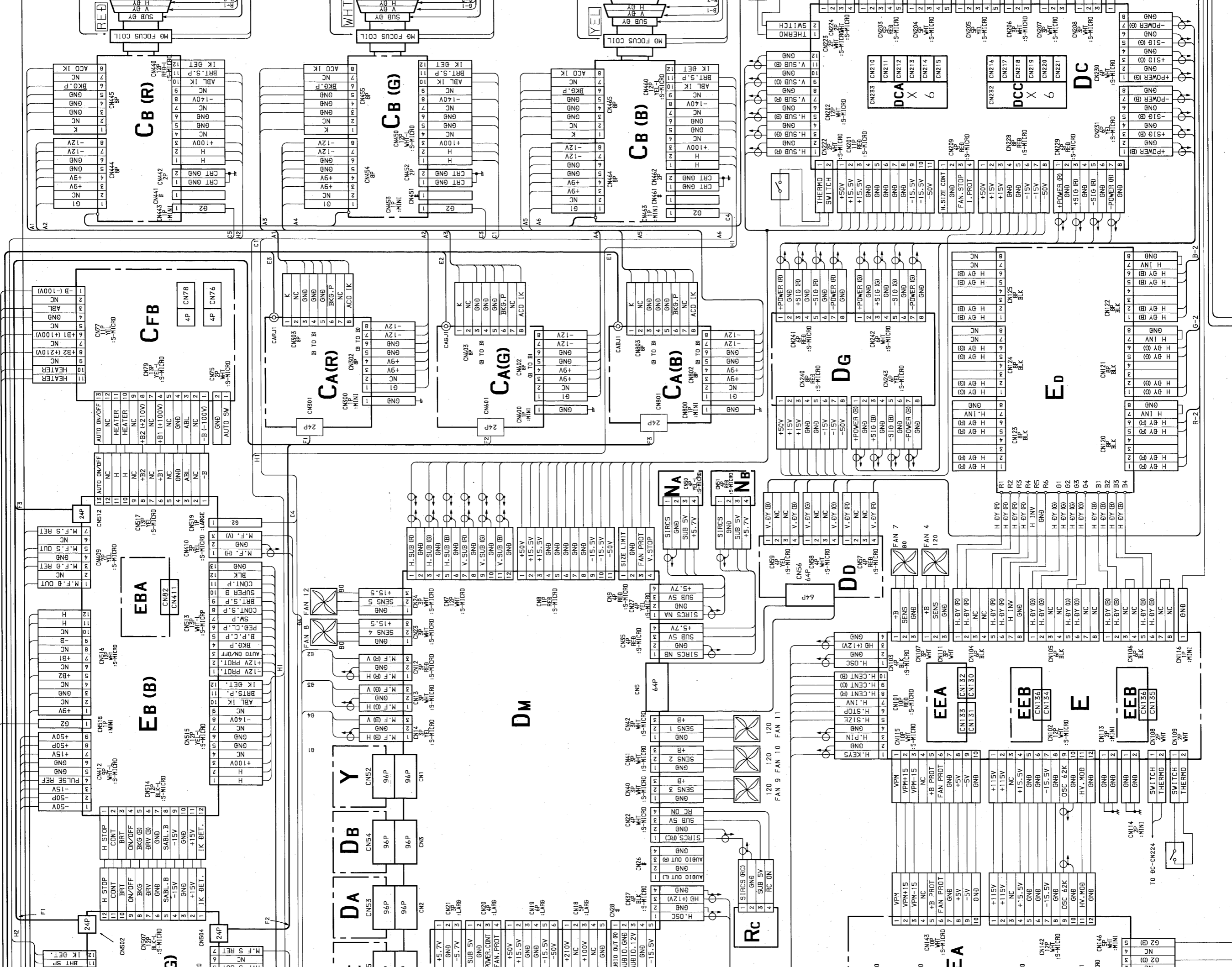

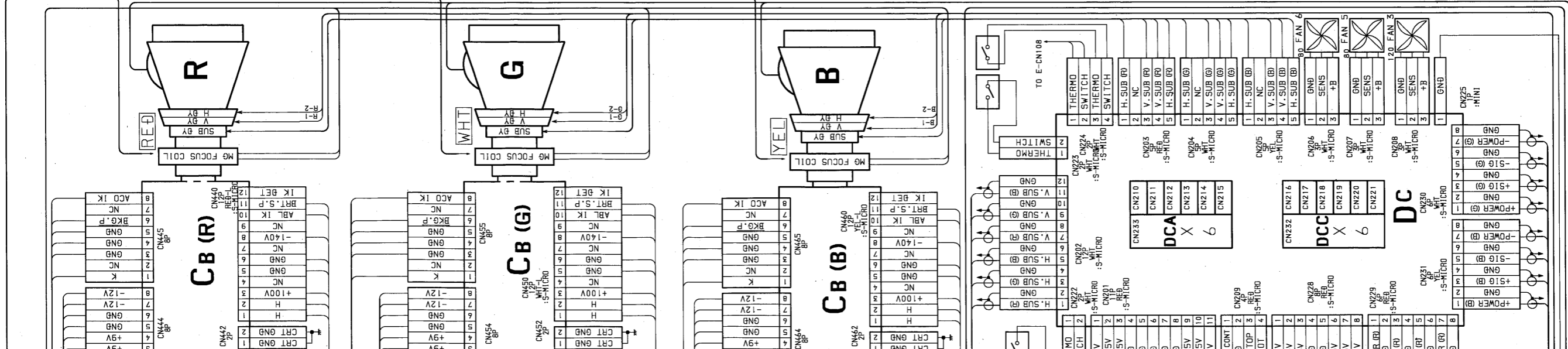

6-4. SCHEMATIC DIAGRAMS AND PRINTED WIRING BOARDS

Note:

- All capacitors are in μF unless otherwise noted. pF: μF 50WV or less are not indicated except for electrolytics.
- All electrolytics are in 50V unless otherwise specified.
- All resistors are in ohms, 1/4W in resistance, 1/10W in chip resistance.
- $k\Omega = 1000\Omega$, $M\Omega = 1000k\Omega$
- : nonflammable resistor.
- : fusible resistor.
- Δ : internal component.
- : panel designation and adjustment for repair.
- All variable and adjustable resistors have characteristic curve B, unless otherwise noted.
- # marked in these schematic diagrams signifies not mounted.

- Voltage value is the reference value between it and the earth, when NTSC 3.58 color bar signal is received from color bar generator (digital multi-meter used : 10M ohms/V DC).
- Displays a list of BB, BA board modes.

(PAL, SECAM, NTSC 3.58, NTSC 4.43, S-VIDEO, R.G.B MODE) Display a list of existing voltages, when board E has issued a white pattern of internal signals.

- Unit of voltage values is V (volt).
- * : Measurement disabled.
- : B + line.
- : B - line.
- (Actual measured value may be different).
- Circled numbers are waveform references.

Reference information
RESISTOR : RN METAL FILM
: RC SOLID

- : FPRD NONFRAMMABLE CARBON
- : FUSE NONFLAMMABLE FUSIBLE
- : RS NONFLAMMABLE METAL OXIDE
- : RB NONFLAMMABLE CEMENT
- : RW NONFLAMMABLE WIREWOUND
- : * ADJUSTMENT RESISTOR

COIL : LF-8L MICRO INDUCTOR

- CAPACITOR : TA TANTALUM
: PS STYROL
: PP POLYPROPYLENE
: PT MYLAR
: MPS METALIZED POLYESTER
: MPP METALIZED POLYPROPYLENE
: ALB BIPOLAR
: ALT HIGH TEMPERATURE
: ALR HIGH RIPPLE

The components identified by in this basic schematic diagrams have been carefully factory-selected for each set in order to satisfy regulations regarding X-ray radiation. Should replacement be required replace only with the value originally used.

When replacing components identified by , make the necessary adjustments indicated. If results do not meet the specified value, change the component identified by and repeat the adjustment until the specified value is achieved.

(Refer to RV1, RV2, RV301, RV401, RV501, adjust on Page 109 to 112.)

Part replaced	Adjustment
IC2, D9, D12, C13, R20, R21, R22, R23, R24, R32, R33, R35, R36, R82 (PA BOARD) PA MOUNT HV BLOCK	HV HOLD DOWN RV2 (PA BOARD)
IC1, IC7, IC8, IC9, IC10, IC11, IC12, IC13, R38, R39, R63, R64, R65, R66, R69, R72, R78, R80, R132, X1 (PA BOARD) PA MOUNT, PB MOUNT HV BLOCK	HV REGULATOR RV1 (PA BOARD)
IC303, IC304, D303, R330, R331, R332, R333, R334, R348 (CBR BOARD) IC403, IC404, D403, R430, R431, R432, R433, R434, R448 (CBG BOARD) IC503, IC504, D503, R530, R531, R532, R533, R543, R548 (CBB BOARD) CBR MOUNT, CBG MOUNT CBB MOUNT, HV BLOCK	IK PROTECTOR RV301 (CBR BOARD) RV401 (CBG BOARD) RV501 (CBB BOARD)

Note: The component identified by shading and mark are critical for safety. Replace only with part number specified.

Note: Les composants identifiés par une trame et une marque sont critiques pour la sécurité. Ne les remplacer que par une pièce portant le numéro spécifié.

SCHEMATIC DIAGRAMS AND PRINTED WIRING BOARDS

BA BOARD

The following diagram has been divided into 3 sections as noted on the grid shown below.

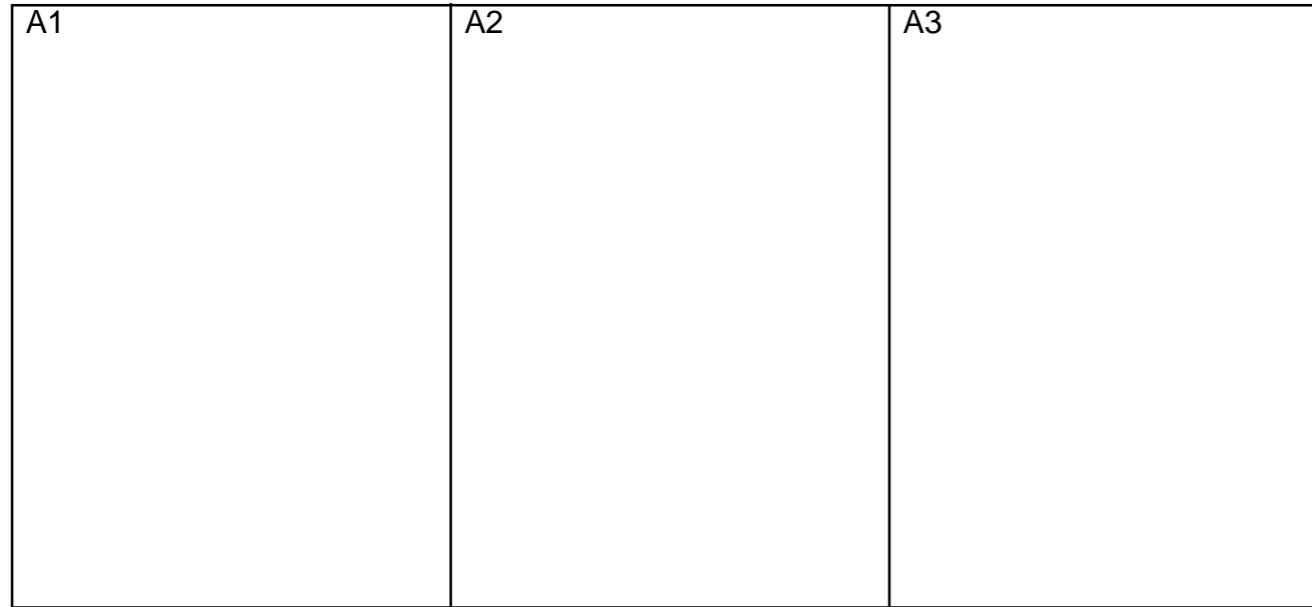

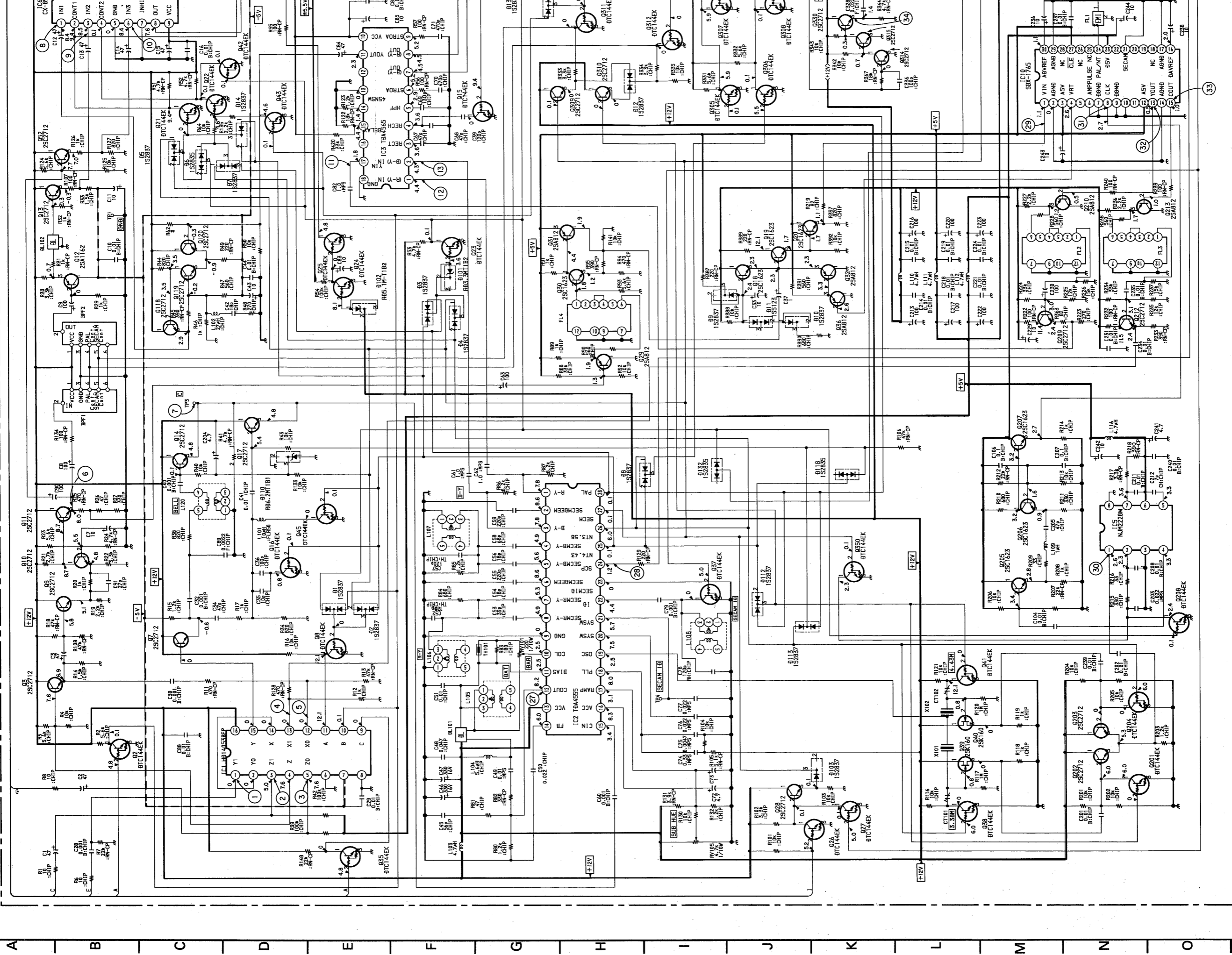

Schematic diagram
BA board

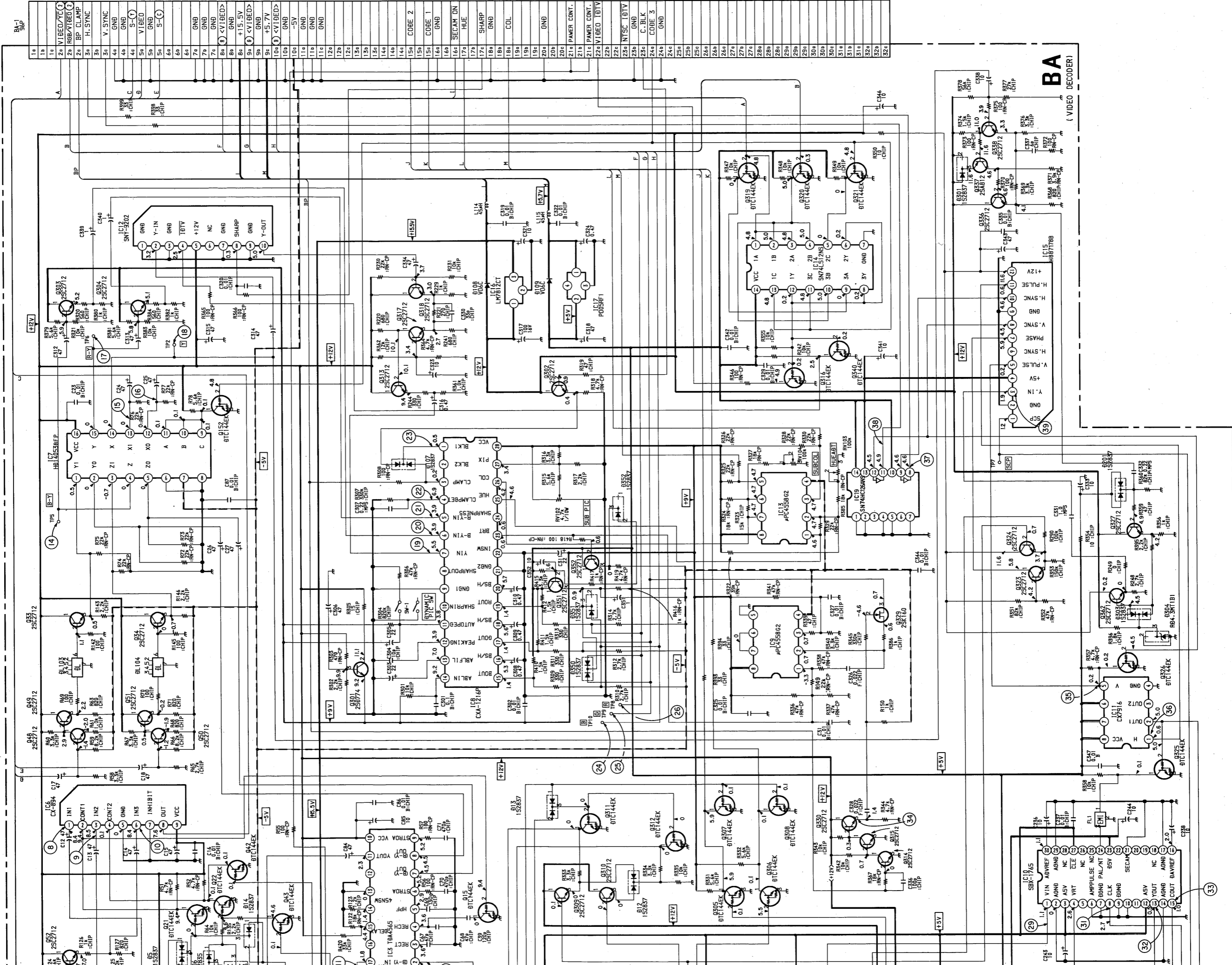

1a	BP
1b	BP
1c	BP
2a	BP
2b	BP
2c	BP
3a	BP
3b	BP
3c	BP
4a	BP
4b	BP
4c	BP
5a	BP
5b	BP
5c	BP
6a	BP
6b	BP
6c	BP
7a	BP
7b	BP
7c	BP
8a	BP
8b	BP
8c	BP
9a	BP
9b	BP
9c	BP
10a	BP
10b	BP
10c	BP
11a	BP
11b	BP
11c	BP
12a	BP
12b	BP
12c	BP
13a	BP
13b	BP
13c	BP
14a	BP
14b	BP
14c	BP
15a	BP
15b	BP
15c	BP
16a	BP
16b	BP
16c	BP
17a	BP
17b	BP
17c	BP
18a	BP
18b	BP
18c	BP
19a	BP
19b	BP
19c	BP
20a	BP
20b	BP
20c	BP
21a	BP
21b	BP
21c	BP
22a	BP
22b	BP
22c	BP
23a	BP
23b	BP
23c	BP
24a	BP
24b	BP
24c	BP
25a	BP
25b	BP
25c	BP
26a	BP
26b	BP
26c	BP
27a	BP
27b	BP
27c	BP
28a	BP
28b	BP
28c	BP
29a	BP
29b	BP
29c	BP
30a	BP
30b	BP
30c	BP
31a	BP
31b	BP
31c	BP
32a	BP
32b	BP
32c	BP

BA
(VIDEO DECODER)

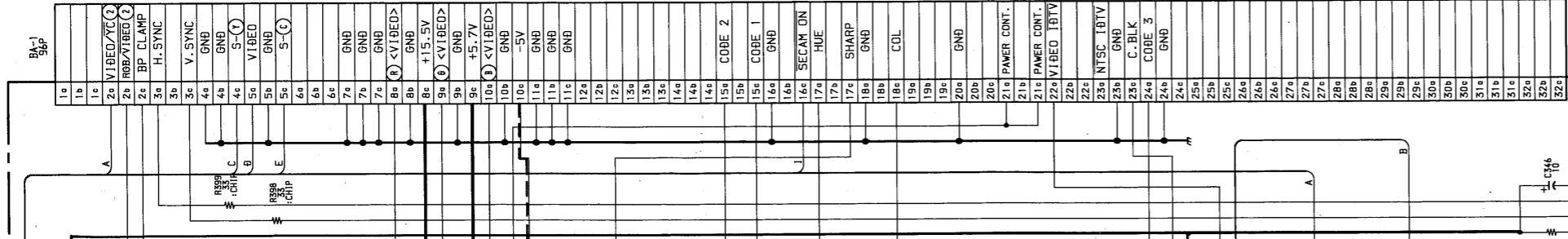

TO BM BOARD
CN60

BA BOARD

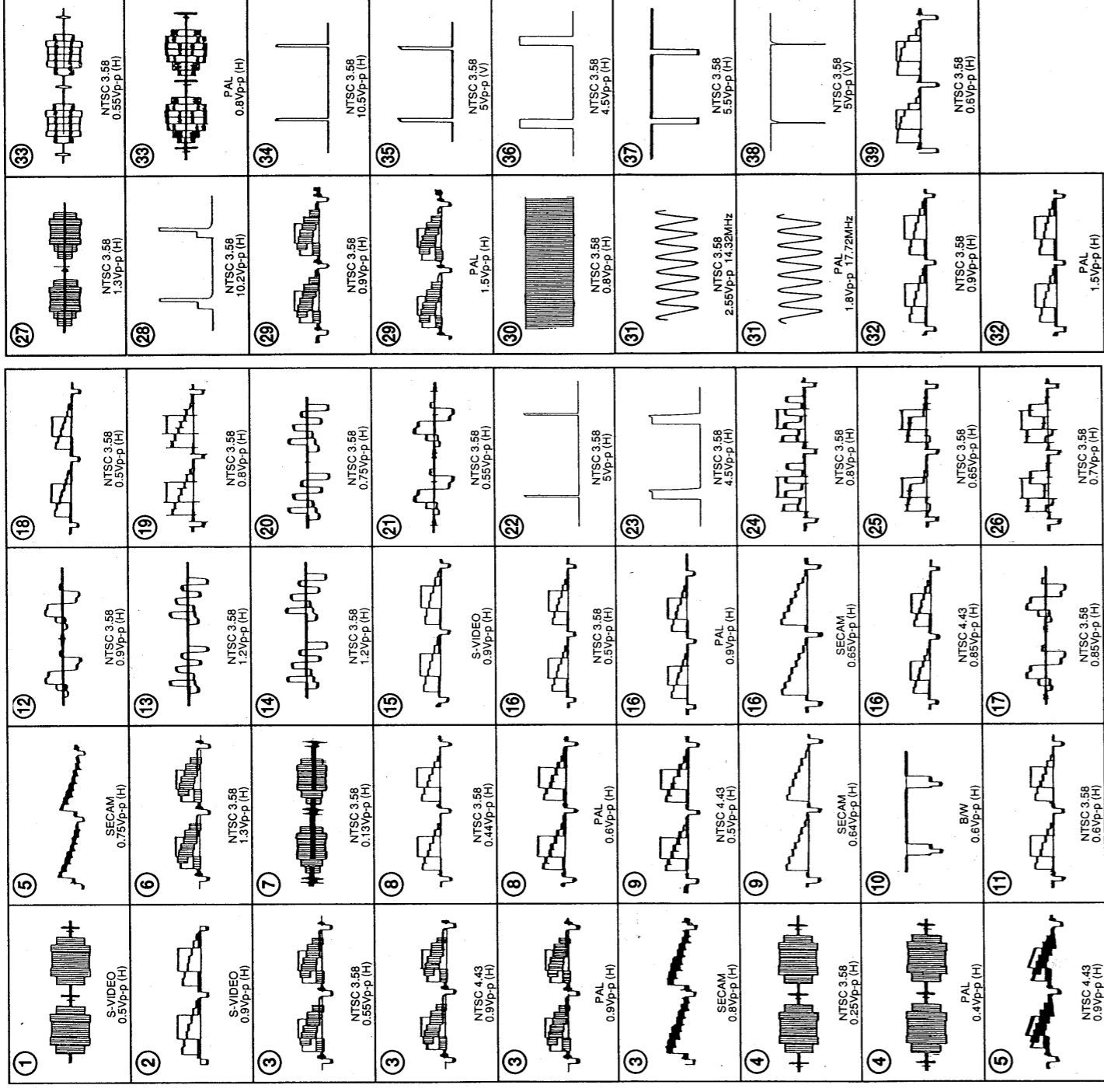

BA BOARD

Pin No.	NTSC 3.58	PAL SECAM	NTSC 4.43	S-VIDEO	R.G.B
1	0	-	-0.7	-0.3	-
2	0	-	-0.7	-	-0.7
3	5.0	-	-	7.6	-
4	7.6	-	-	5.0	-
5	0	-	-	12.1	-
6	0	-	-	7.8	-
7	12.1	-	0.1	0	0
8	0	-	-0.7	-	-0.6
9	0	-	-0.7	-	-0.7
10	0	-	-0.6	-0.3	0
11	5.6	-	4.3	-	4.2
12	5.3	-	4.2	-	4.2
13	8.3	-	-	-	7.3
14	2.5	-	2.9	-	2.9
15	7.5	5.8	5.8	-	5.8
16	5.7	7.9	7.2	-	-
17	0.1	-	5.9	-	0
18	6.0	0.1	0.1	-	0.1
19	0.1	-	6.0	-	2.5
20	0.1	6.0	0	-	-
21	2.3	2.5	-	-	-
22	1.8	2.0	2.0	2.0	-
23	8.4	4.8	-	-	-
24	9.4	-	0.1	0.1	0.1
25	0.1	-	10.2	10.2	0
26	6.9	-	-	-	4.0
27	1.4	1.6	-	-	1.6
28	1.4	1.6	-	-	-
29	1.4	1.6	-	-	-
30	1.1	1.4	1.4	-	-
31	0.5	0.8	0.8	0.8	-
32	0	5.0	5.0	-	5.0
33	5.0	0	-	-	0

REF.	NTSC 3.58		PAL SECAM		NTSC 4.43		S-VIDEO		R.G.B	
	B	C	B	C	B	C	B	C	B	C
Q7	12	-0.6	-0.7	-0.6	-0.3	-0.6	-0.3	-0.6	-0.6	-
Q8	12.1	0	0	0	0	0	0	0	0	12.1
Q14	0.1	*	5.6	-	-	-	-	-	2.5	6.0
Q16	0.8	*	1.0	0	0	0.5	0	0.3	0	5.3
Q17	5.4	*	0	-	-	-	-	0	0	6.7
Q21	9.4	0.1	0.1	-	-	-	-	1.8	6.3	0.1
Q22	4.6	5.2	1.0	0	1.0	5.2	10.2	5.5	5.5	5.9
Q26	5.2	5.0	5.0	5.0	5.0	5.0	5.0	5.0	5.0	5.0
Q27	5.0	0	0	-	-	-	-	0	0	6.7
Q28	0.1	-	-	-	-	-	-	-	-	-
Q37	5.0	0	0	-	-	-	-	0	0	5.4
Q38	6.0	*	0.1	0.1	0.1	0.1	0.1	0.1	0.1	0.1
Q41	0	*	-	-	-	-	-	5.4	0	0
Q43	4.6	5.2	0	0	0	5.2	7.8	5.2	5.0	5.0
Q45	0.1	*	-	-	-	-	-	5.9	0	6.0
Q201	6.0	*	-	-	-	-	-	0	0	5.4
Q202	6.0	*	-	-	-	-	-	0	0	12.1
Q203	12	-	-	-	-	-	-	5.3	6.0	5.3
Q204	6.0	*	0.1	0.1	0.1	0.1	0.1	0.1	0.1	0.1
Q208	0.1	6.7	0	-	-	-	-	0	0	6.0
Q305	5.9	0.1	-	-	-	-	-	5.9	0	6.0
Q306	0.1	-	-	-	-	-	-	5.8	0	5.8
Q307	0.1	6.7	-	-	-	-	-	0	0	6.7
Q308	0.1	6.7	-	-	-	-	-	5.9	0	6.7
Q309	0.1	*	6.0	-	-	-	-	6.0	0	6.0
Q310	0	*	-	-	-	-	-	5.4	0	5.4
Q311	0	6.2	0	0.8	4.8	0	0.8	4.8	0	0.8
Q312	0	6.2	0	0	0	0	0	0	0	0
Q325	0.1	5.0	0	0	0	0	0	0	0	0
Q350	0.1	6.0	0	0	0	0	0	0	0	0
Q350	2.3	0	0	0	0	0	0	0	0	1.8

A1

SCHEMATIC DIAGRAMS AND PRINTED WIRING BOARDS

BA BOARD

The following board layout has been divided into 3 sections as noted on the grid shown below.

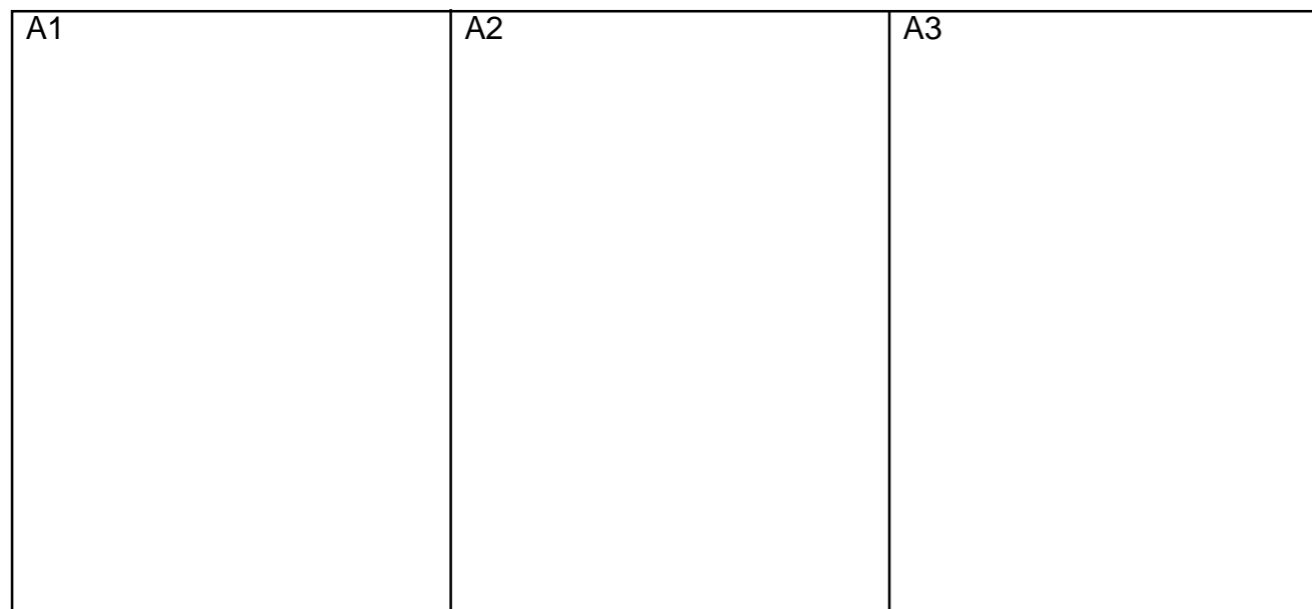

BA BOARD

IC1	SYSTEM SW-1	Q208	GEN SW
IC2	DECODER	Q209	NT/PAL Y BUFF-2
IC3	TRANSIENT	Q210	NT/PAL Y BUFF-1
IC5	CLK GEN.	Q212	NT/PAL C BUFF-2
IC6	VIDEO AMP	Q213	NT/PAL Y BUFF-1
IC7	SYSTEM SW-2	Q301	9V REG.
IC8	MATRIX	Q302	BLK BUFF-1
IC9	BRT CONT-2	Q303	B-Y BUFF-2
IC10	COMB FILTER	Q304	R-Y BUFF-2
IC11	50/60 DET.	Q305	CODE 2 SW-1
IC12	SHARPNESS	Q306	CODE 1 SW-1
IC13	LEVEL SHIFT-1	Q307	CODE SW-2
IC14	MODE DET.	Q308	CODE SW-2
IC15	JUNGLE	Q309	NT 3.58 SW
IC16	12V REG.	Q310	NT 4.43 SW
IC17	5V REG.	Q311	TRAP SW
IC19	SYNC BUFF.	Q312	TRAP SW
		Q313	Y AMP-3
		Q314	CLAMP BUFF-1
Q2	MODE SW-1	Q315	CLAMP BUFF-2
Q3	VIDEO BUFF-1	Q316	MODE DET
Q7	C BUFF.	Q317	Y AMP-2
Q8	MODE SW-1	Q318	Y AMP
Q9	VIDEO AMP-1	Q319	MODE SW-7
Q10	VIDEO AMP-2	Q320	MODE SW-8
Q11	VIDEO AMP-3	Q321	MODE SW-9
Q12	Y BUFF-1	Q323	REF DC BUFF.
Q13	Y BUFF-2	Q324	BGP SHIFT
Q14	SECAM C BUFF.	Q325	50/60 SW
Q15	MODE SW-10	Q326	V SYNC SW
Q16	C FILTER SW	Q327	Y CLAMP-2
Q17	NT/PAL C BUFF.	Q329	BRT CONT-1
Q18	CLAMP-4	Q330	CLAMP BUFF-3
Q19	CLAMP-6	Q336	Y AMP-6
Q20	NT/PAL VIDEO BUFF.	Q337	Y AMP-5
Q21	Y MODE SW-6	Q338	Y AMP-4
Q22	Y MODE SW-7	Q340	MODE DET.
Q23	B/W SW-4	Q350	GEN SW
Q24	POWER CONT-1	Q351	CLIP BUFF.
Q25	POWER CONT-2	Q352	CLIP BUFF.
Q26	SECAM SW-1	Q362	Y BUFF.
Q27	SECAM SW-2		
Q28	SECAM SW-3		
Q29	NT/PAL VIDEO	D1	SYSTEM DET-1
Q30	NT/PAL VIDEO AMP-1	D2	SYSTEM DET-2
Q31	NT/PAL VIDEO AMP-2	D3	B/W SW-1
Q32	CLAMP-5	D4	B/W SW-2
Q33	R-Y BUFF-1	D5	Y MODE SW-1
Q34	B-Y BUFF-1	D6	Y MODE SW-2
Q35	MODE SW-2	D7	Y MODE SW-3
Q36	CLAMP	D8	MODE SW-3
Q37	ID	D9	CLAMP-3
Q38	NT OSC SW	D10	CLAMP-2
Q39	NT CLK BUFF-1	D11	CLAMP-1
Q40	PAL CLK BUFF-2	D12	NT 3.58 DET.
Q41	PAL OSC SW	D13	MODE SW-11
Q42	Y MODE SW-7	D14	Y MODE SW-4
Q43	Y MODE SW-5	D101	B/W SW-3
Q45	C FILTER SW	D102	POWER CONT.
Q48	R-Y AMP-1	D103	SECAM SW-4
Q49	R-Y AMP-2	D107	BLK ADD-2
Q50	B-Y AMP-1	D108	+12V PROT.
Q51	B-Y AMP-2	D109	+5V PROT.
Q52	VIDEO BUFF-2	D110	SECAM SW
Q118	NT/PAL Y AMP-3	D112	MODE SW-4
Q119	NT/PAL Y AMP-1	D113	MODE SW-5
Q120	NT/PAL Y AMP-2	D118	MODE SW-6
Q152	SYSTEM MODE SW-2	D132	C FILTER SW
Q201	NT CLK SW	D201	Y CLAMP-1
Q202	CLK BUFF-3	D301	LEVEL SHIFT-2
Q203	CLK BUFF-4	D303	Y LEVEL ADJ-2
Q204	PAL CLK SW	D304	Y LEVEL ADJ-1
Q205	CLK AMP-1	D350	LIMIT
Q206	CLK AMP-2	D351	LIMIT
Q207	CLK AMP-3	D352	LEVEL SHIFT

**BA BOARD
(COMPONENT LIST)**

IC	
IC1	C-6
IC2	B-7
IC3	A-2
IC5	C-10
IC6	D-2
IC7	D-1
IC8	B-3
IC9	C-4
IC10	D-9
IC11	B-2
IC12	A-4
IC13	D-3
IC14	B-2
IC15	A-6
IC16	C-5
IC17	C-5
IC19	B-2
TRANSISTOR	
Q2	C-6
Q7	C-7
Q12	B-6
Q14	C-7
Q16	C-6
Q19	D-8
Q22	B-4
Q23	B-5
Q24	C-5
Q27	A-7
Q28	A-7
Q29	C-8
Q32	D-8
Q36	D-8
Q42	B-5
Q43	B-5
Q49	E-1
Q51	E-1
Q118	B-2
Q119	B-2
Q152	C-1
Q205	C-8

A2

BA

[VIDEO DECODER]

- BA BOARD - <Component Side>

BA BOARD
(COMPONENT SIDE)

IC	Q206 C-8	Q207 C-9	Q301 B-4	Q310 B-5	Q311 C-5	Q312 C-6	Q313 C-4	Q321 B-1	Q329 C-4	Q336 A-6	Q351 D-3	Q352 D-3	Q362 A-7																				
IC1	C-6	IC2	B-7	IC3	A-2	IC5	C-10	IC6	D-2	IC7	D-1	IC8	B-3	IC9	C-4	IC10	D-9	IC11	B-2	IC12	A-4	IC13	D-3	IC14	B-2	IC15	A-6	IC16	C-5	IC17	C-5	IC19	B-2
DIODE	D2 A-7	D6 B-5	D7 B-5	D10 D-7	D13 C-6	D14 B-5	D101 B-5	D103 A-7	D108 C-5	D109 D-5	D110 D-7	D132 A-6	D201 A-6	D301 A-6	D350 D-3	D351 D-4	D352 D-3																
TRANSISTOR	Q2 C-6	Q7 C-7	Q12 B-6	Q14 C-7	Q16 C-6	Q19 D-8	Q22 B-4	Q23 B-5	Q24 C-5	Q27 A-7	Q28 A-7	Q29 C-8	Q32 D-8	Q36 D-8	Q42 B-5	Q43 B-5	Q49 E-1	Q51 E-1	Q118 B-2	Q119 B-2	Q152 C-1	Q205 C-8											
ADJUSTING ELEMENT	CT101 A-9	CT102 A-9	RV101 B-8	RV102 A-4	RV103 D-2	RV104 D-2	RV105 A-9																										

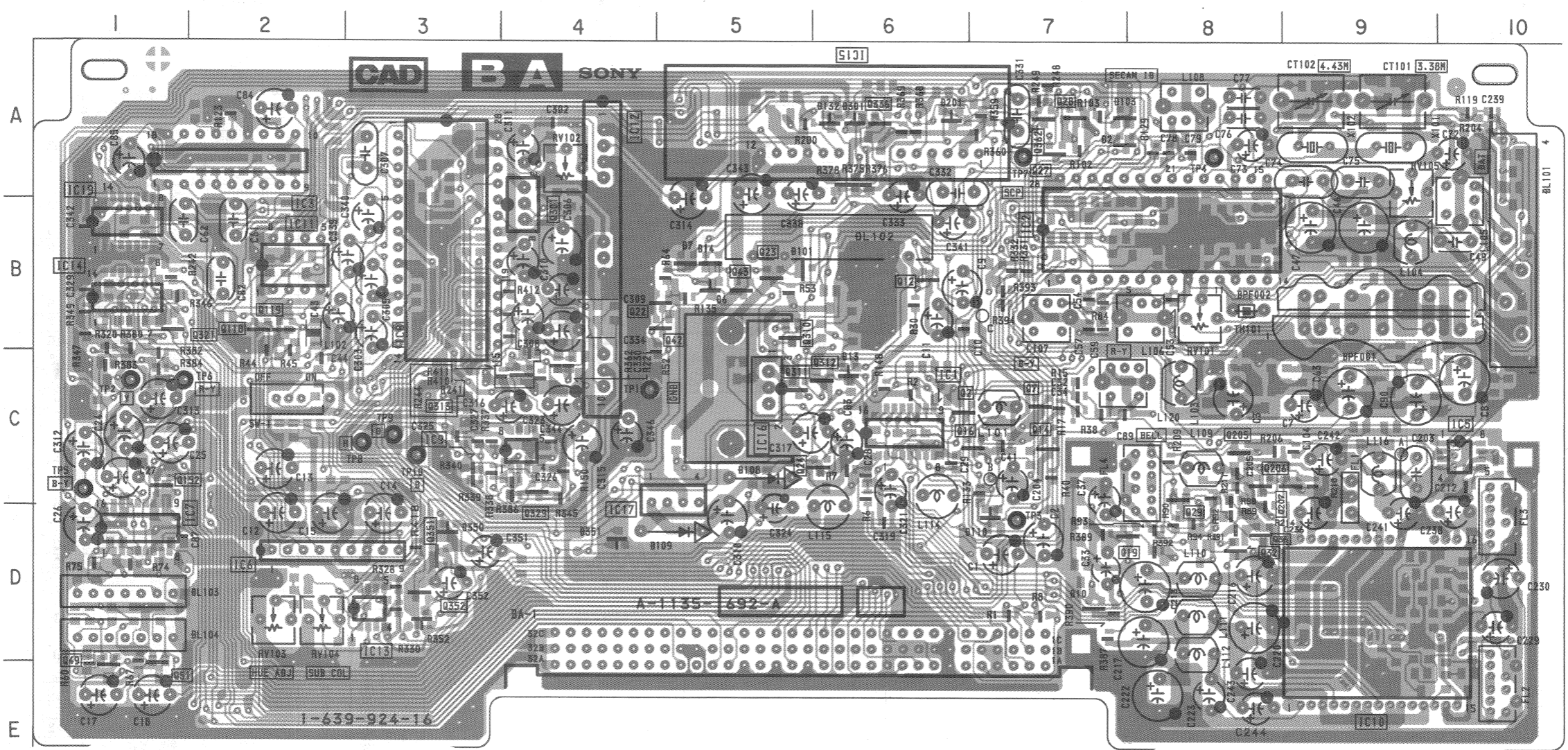

<Conductor

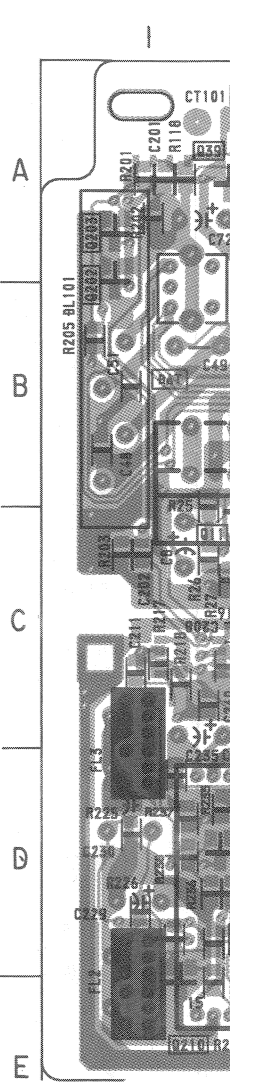

BA BOARD IC5 NJM2228

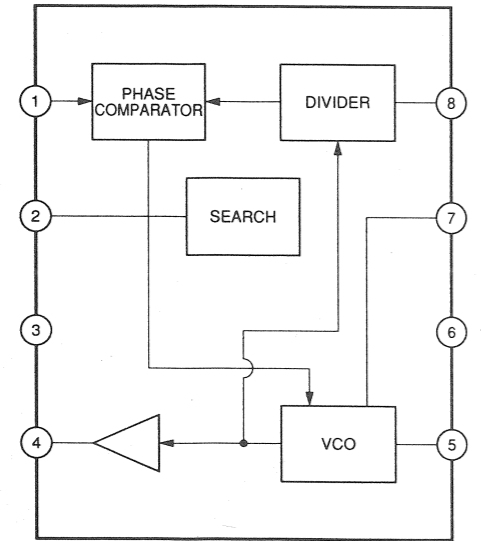

A3

<Conductor Side>

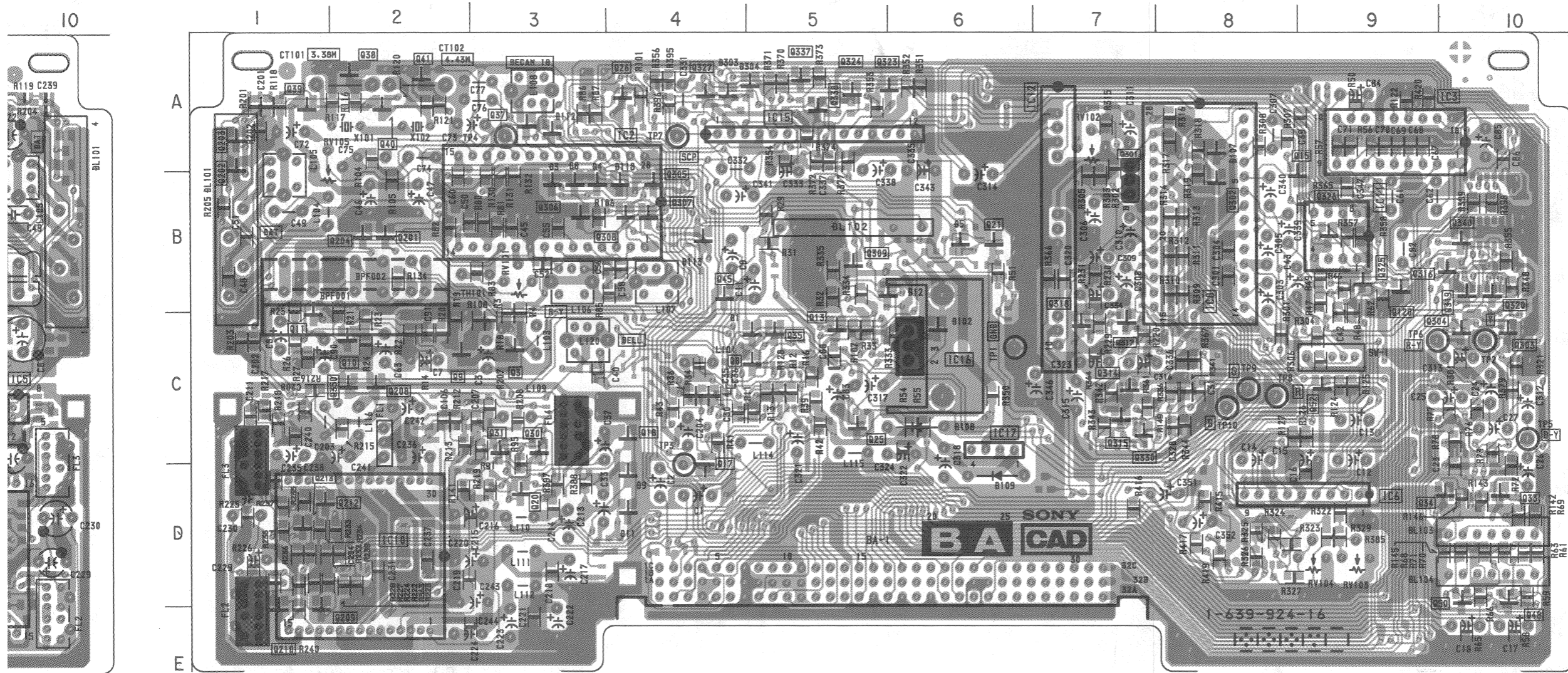

**BA BOARD
(CONDUCTOR SIDE)**

IC		Q303	B-10
IC2	B-3	Q304	C-9
IC3	A-9	Q305	B-4
IC6	D-9	Q306	B-3
IC8	B-8	Q307	B-4
IC10	D-2	Q308	B-4
IC11	B-9	Q309	B-5
IC12	A-7	Q314	C-7
IC15	A-5	Q315	C-7
IC16	C-6	Q316	B-9
IC17	C-6	Q317	C-7
		Q318	C-7
		Q319	B-10
		Q320	B-10
		Q323	A-5
		Q324	A-5
		Q325	B-9
		Q326	B-9
		Q327	A-4
		Q330	C-7
		Q337	A-5
		Q338	A-5
		Q340	B-9
		Q350	C-2
TRANSISTOR		DIODE	
Q3	C-3	D1	C-5
Q8	C-5	D3	B-3
Q9	C-2	D4	B-3
Q10	C-2	D5	B-6
Q11	C-1	D8	B-3
Q13	C-5	D9	D-4
Q15	A-8	D11	D-4
Q17	C-4	D12	B-6
Q18	C-4	D102	C-6
Q20	D-3	D107	A-8
Q21	B-6	D108	C-6
Q25	C-5	D109	D-6
Q26	A-4	D112	A-3
Q30	C-3	D113	B-4
Q31	C-3	D118	C-4
Q33	D-10	D303	A-4
Q34	D-9	D304	A-4
Q35	C-5	ADJUSTING ELEMENT	
Q37	A-3	CT101	A-1
Q38	A-2	CT102	A-2
Q39	A-1	RV101	B-3
Q40	A-2	RV102	A-7
Q41	A-2	RV103	D-9
Q45	B-4	RV104	D-9
Q48	D-10	RV105	A-1
Q50	D-9		
Q52	C-8		
Q120	B-9		
Q201	B-2		
Q202	A-1		
Q203	A-1		
Q204	B-2		
Q208	C-2		
Q209	E-1		
Q210	E-1		
Q212	D-1		
Q213	D-1		
Q301	B-7		
Q302	B-8		

- : Pattern from the side which enables seeing.
- ▨ : Pattern of the rear side.

SCHEMATIC DIAGRAMS AND PRINTED WIRING BOARDS

BB/BD BOARD

The following boards layout has been divided into 3 sections as noted on the grid shown below.

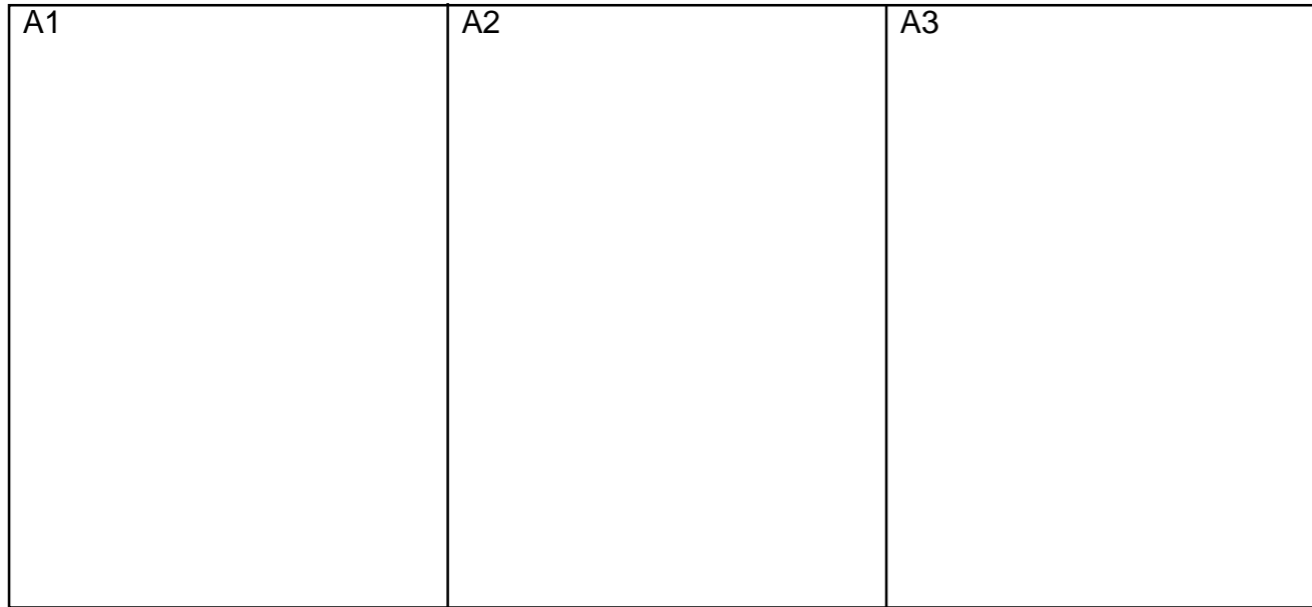

A1 **BB BOARD
(COMPONENT SIDE)**

IC	
IC401	A-2
IC402	A-9
IC403	C-5
IC404	C-2
IC405	C-3
IC407	A-3
IC408	D-4
IC409	D-6
IC410	C-6
IC411	C-6
IC413	A-8
IC414	B-9
IC415	C-9
IC416	D-9
IC417	E-9
IC418	B-9
IC419	C-9
IC420	D-9
IC422	C-3
IC423	C-4
IC424	D-3

TRANSISTOR	
Q401	A-8
Q402	C-5
Q440	E-4
Q458	A-2
Q459	B-2
Q460	A-2
Q502	D-1
Q504	D-2
Q517	E-6
Q520	C-3
Q521	C-3
Q522	E-7
Q534	B-3
Q535	B-3
Q536	B-2
Q541	D-8
Q542	D-7
Q543	D-7
Q544	D-7
Q546	A-2
Q552	C-4
Q701	C-7
Q702	C-6
Q703	C-7
Q704	C-7
Q707	C-7
Q741	C-2
Q751	C-7
Q800	B-3

DIODE	
D401	A-10
D402	C-5
D523	D-7
D528	D-3

- **BB BOARD** - <Component Side>

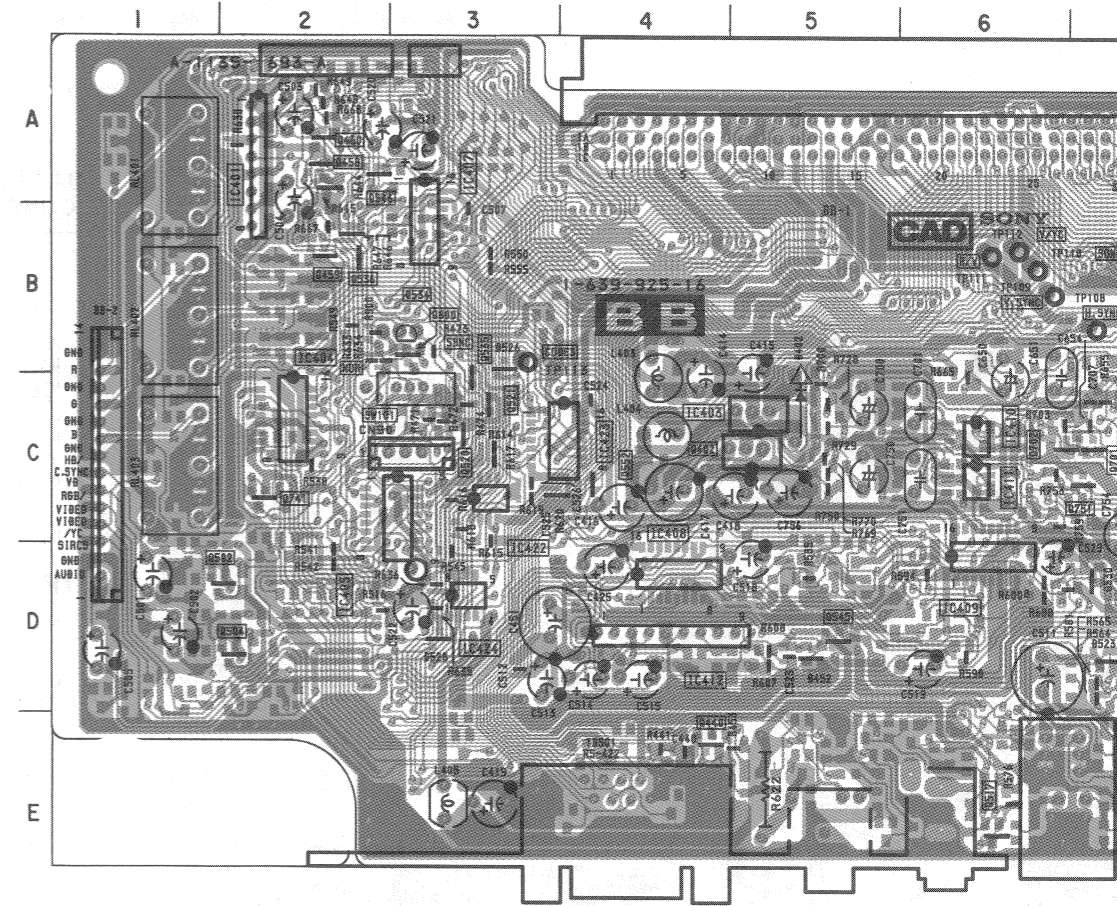

<Conductor Side>

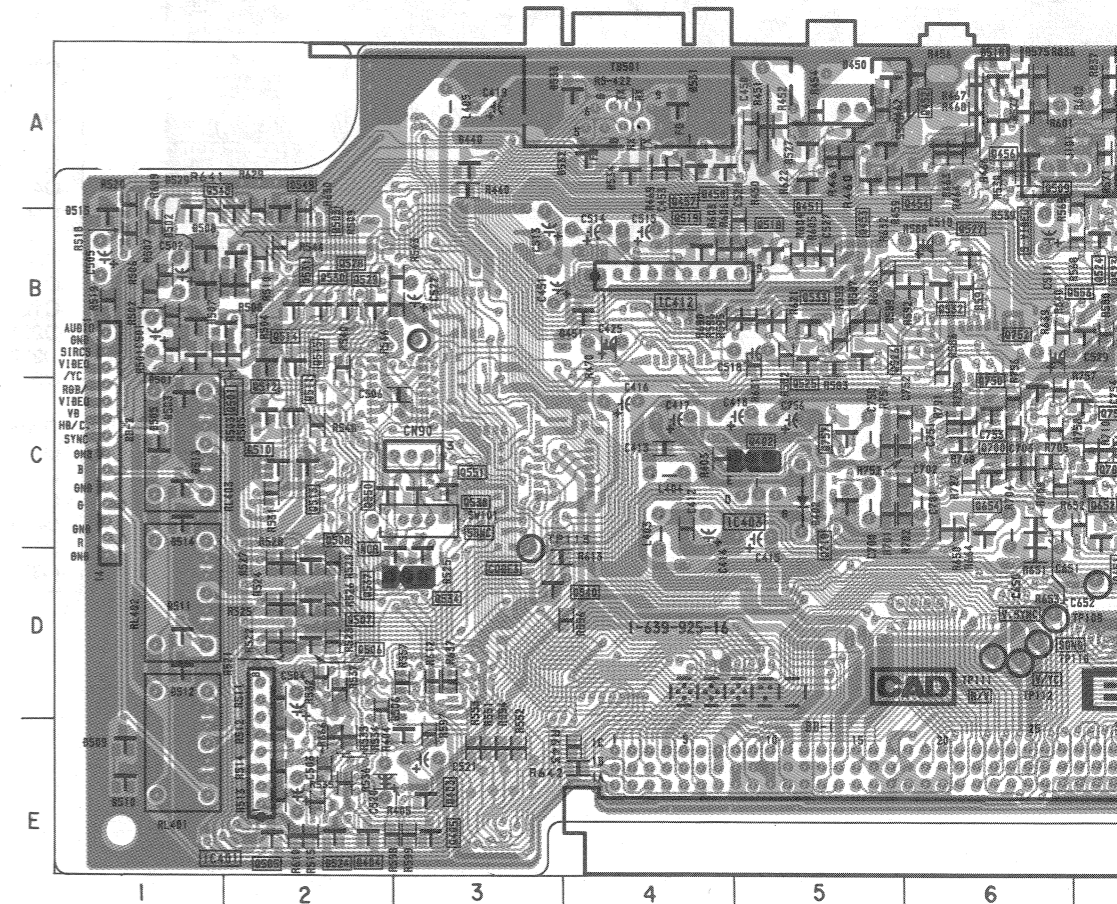

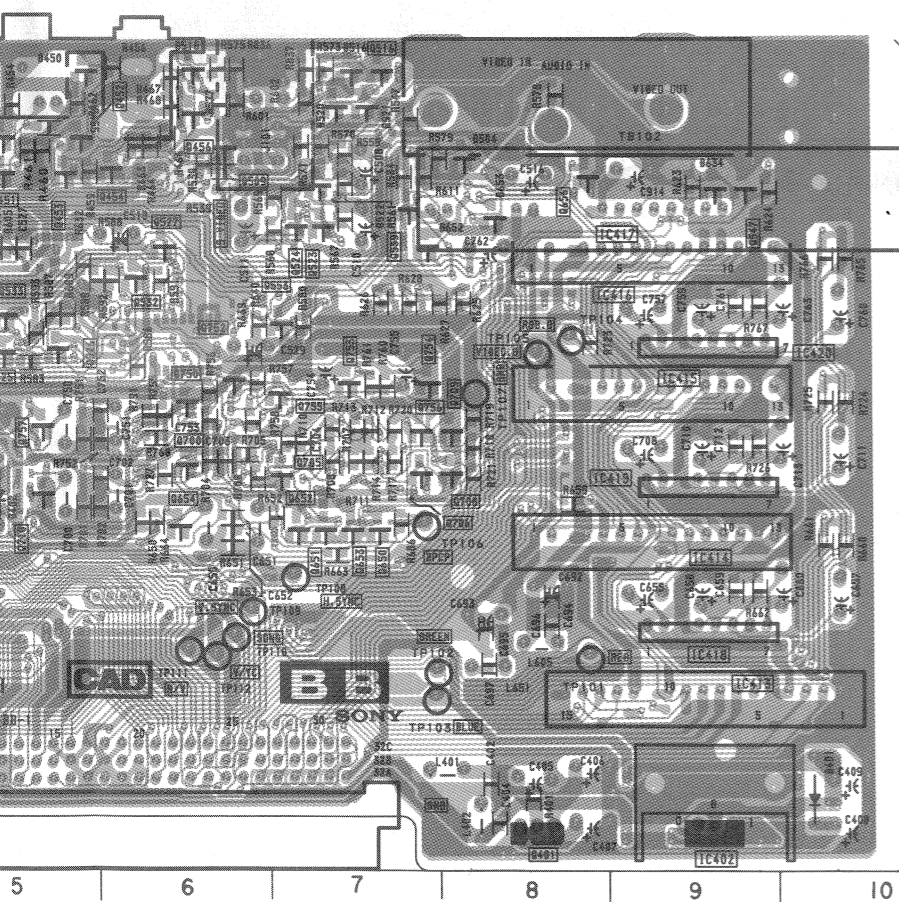
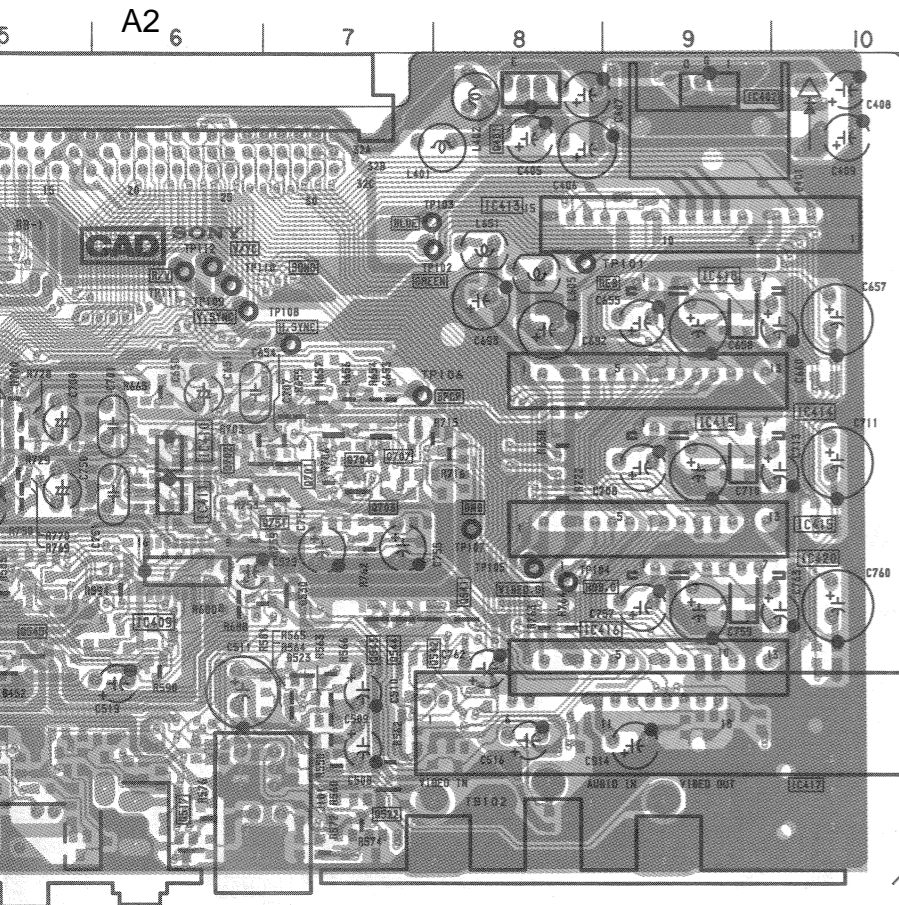

**BB BOARD
(CONDUCTOR SIDE)**

IC		TRANSISTOR		DIODE	
IC401	E-2	Q401	E-8	D401	E-10
IC402	E-9	Q402	C-5	D402	C-5
IC403	C-5	Q403	E-3	D440	A-3
IC413	D-9	Q404	E-2	D450	A-5
IC414	C-9	Q405	E-3	D501	B-1
IC415	C-9	Q450	A-4	D502	B-1
IC416	B-9	Q451	A-5	D503	C-1
IC417	B-9	Q452	A-6	D505	C-1
IC418	D-9	Q453	A-5	D506	E-3
IC419	C-9	Q454	A-6	D507	B-1
IC420	B-9	Q456	A-6	D508	B-1
		Q501	B-2	D509	E-1
		Q503	B-2	D510	E-1
		Q506	D-2	D511	D-1
		Q507	D-2	D512	D-1
		Q508	D-2	D513	C-1
		Q509	A-6	D514	C-1
		Q510	C-2	D516	A-7
		Q511	C-2	D518	A-6
		Q512	C-2	D520	A-7
		Q513	C-2	D521	A-7
		Q514	B-2	D522	A-7
		Q515	B-2	D524	E-2
		Q516	A-7	D525	D-3
		Q523	B-7	D526	D-3
		Q524	B-7	D527	A-5
		Q528	B-2	D529	A-1
		Q529	B-2	D531	A-4
		Q530	B-2	D532	A-4
		Q531	B-2	D533	A-4
		Q534	D-3	D534	A-4
		Q537	D-2	D634	A-9
		Q538	C-3	D652	B-7
		Q539	B-7	D653	B-8
		Q540	D-3		
		Q547	A-9		
		Q548	A-2		
		Q549	A-2		
		Q550	C-2		
		Q551	C-3		

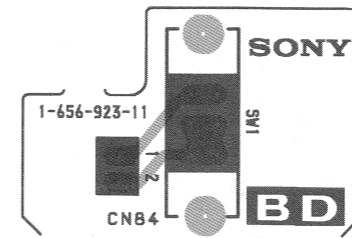

BB BOARD

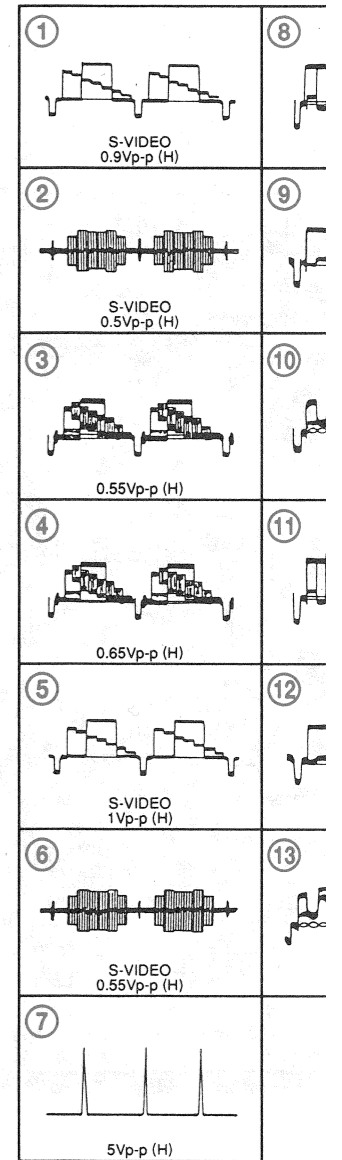

• : Pattern from the side which enables seeing.
• : Pattern of the rear side.

A3

BB BOARD

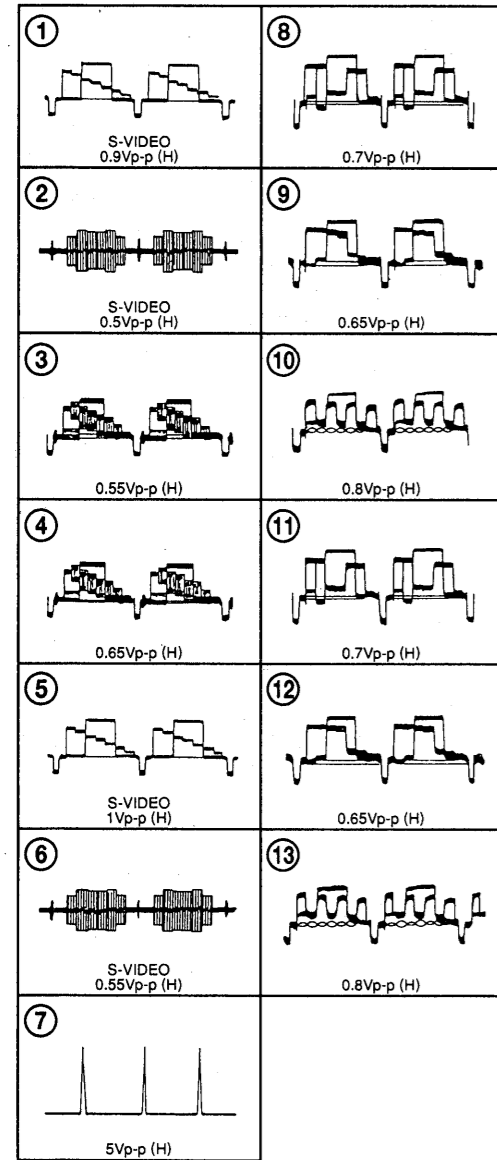

BB BOARD

REF.	Pin No.	NTSC 3.58	PAL	SECAM	NTSC 4.43	S-VIDEO	R.G.B	
IC404	①	0	-	-	-	-	1.4	
	②	0.1	-	-	-	1.6	0	
	③	0	-	-	-	-	1.4	
	④	0.5	-	-	-	1.8	1.8	
	⑤	0.1	-	-	-	1.4	0	
	⑥	0	-	-	-	-	12.1	
	⑦	0	-	-	-	-	12.1	
	⑧	0	-	-	-	-	12.1	
	⑨	1.4	-	-	-	0.1	0	
	⑩	0	-	-	-	-	1.4	
	⑪	1.8	-	-	-	0.5	-	
	⑫	0.5	-	-	-	2.0	1.8	
	⑬	4.3	-	-	-	-	0	
	⑭	0	-	-	-	-	4.8	
	⑮	0	-	-	-	-	4.8	
IC405	①	4.4	-	-	-	0	0	
	②	4.4	-	-	-	0	0	
	③	0.1	-	-	-	-	0	
	④	4.7	-	-	-	-	0	
	⑤	4.7	-	-	-	-	0	
	⑥	4.7	-	-	-	-	0	
	⑦	0	-	-	-	-	-4.8	
	⑧	-	-	-	-	-	0	
	⑨	-	-	-	-	-	3.1	
	⑩	-	-	-	-	0.1	0	
	IC414	⑥	-	-	-	-	-	0
		⑪	-	-	-	-	0.1	0
		⑮	-	-	-	-	-	0
	IC415	⑥	-	-	-	-	-	3.1
		⑪	-	-	-	-	0.1	0
⑮		-	-	-	-	-	0	
IC416	⑥	-	-	-	-	-	3.1	
	⑪	-	-	-	-	0.1	0	
	⑮	-	-	-	-	-	0	
IC423	②	4.8	-	-	-	0	-	
	⑤	0	-	-	-	-	4.8	
	⑥	0	-	-	-	-	4.8	
	⑧	0	-	-	-	-	4.8	
	⑩	0	-	-	-	-	4.8	
	⑪	0	-	-	-	4.8	4.8	
	⑫	0	-	-	-	-	4.8	
⑬	4.7	-	-	-	-	0		

REF.	Pin No.	NTSC 3.58	PAL	SECAM	NTSC 4.43	S-VIDEO	R.G.B
Q458	B	0.5	-	-	-	2.0	1.8
	C	0	-	-	-	0	0
	E	1.3	-	-	-	2.8	2.6
Q459	B	0.5	-	-	-	1.8	1.8
	C	0	-	-	-	0	0
	E	1.3	-	-	-	2.6	2.6
Q460	B	1.8	-	-	-	0.5	-
	C	0	-	-	-	0	0
	E	2.6	-	-	-	1.3	-
Q506	B	0.6	-	-	-	-	-
	C	0	-	-	-	-	0
	E	0	-	-	-	-	1.4
Q507	B	0.6	-	-	-	-	-
	C	0	-	-	-	-	0
	E	0	-	-	-	-	1.4
Q508	B	0.6	-	-	-	-	-
	C	0	-	-	-	-	0
	E	0	-	-	-	-	1.4
Q509	B	0.7	-	-	-	0.6	-
	C	0	-	-	-	0	0
	E	1.4	-	-	-	0.1	0
Q516	B	0.6	-	-	-	0.8	-
	C	0	-	-	-	0	0
	E	0.1	-	-	-	1.6	0
Q517	B	0.7	-	-	-	-	0.6
	C	0	-	-	-	0	0
	E	0.1	-	-	-	1.4	0
Q528	B	4.8	-	-	-	0	-
	C	0	-	-	-	4.0	-
	E	0	-	-	-	0	-
Q529	B	0	-	-	-	4.0	-
	C	1.4	-	-	-	0.1	0
	E	0	-	-	-	0	-
Q530	B	4.8	-	-	-	0	-
	C	0.1	-	-	-	1.6	0
	E	0	-	-	-	0	-
Q531	B	4.8	-	-	-	0	-
	C	0.1	-	-	-	1.4	0
	E	0	-	-	-	0	-
Q539	B	0.3	-	-	-	-	3.8
	C	4.0	-	-	-	2.6	0
	E	0	-	-	-	0	0
Q656	B	0	-	-	-	4.8	-
	C	4.1	-	-	-	0.1	-
	E	0	-	-	-	0	-

BB BOARD

IC401	SYNC SW-1	Q544	MODE SW-22
IC402	+12V REG.	Q546	MODE SW-24
IC403	-12V REG.	Q547	MODE SW-25
IC404	SIG. SW	Q548	MODE SW-26
IC405	MODE SW-1	Q549	MODE SW-27
IC407	SYNC SW-2	Q550	MODE SW-28
IC408	MODE SW-2	Q551	MODE SW-29
IC409	MODE SW-3	Q552	MODE SW-30
IC410	SIG. CLAMP-1	Q650	R CLAMP
IC411	SIG. CLAMP-2	Q651	R BUFF-1
IC412	AUDIO ATT.	Q652	R BUFF-2
IC413	TEST SIG. GEN.	Q653	R BUFF-3
IC414	R SIG. SW	Q654	R BUFF-4
IC415	G SIG. SW	Q656	MODE SW-31
IC416	B SIG. SW	Q700	G CLAMP
IC417	S ON G SYNC SEP.	Q701	G BUFF-1
IC418	R AMP	Q702	G BUFF-2
IC419	G AMP	Q703	G BUFF-3
IC420	B AMP	Q704	CB SW-1
IC422	MODE ENCODER-1	Q705	CB SW-2
IC423	MODE ENCODER-2	Q706	CB SW-3
IC424	MODE ENCODER-3	Q707	CB SW-4
		Q708	G BUFF-4
		Q709	CB SW-5
Q401	+5V REG.	Q710	G BUFF-5
Q402	-5V REG.	Q741	MODE SW-31
Q403	POWER CONT-1	Q750	B CLAMP
Q404	POWER CONT-2	Q751	B BUFF-1
Q405	POWER CONT-3	Q752	B BUFF-2
Q440	SIRCS SW	Q753	B BUFF-3
Q450	SIRCS SW-1	Q754	B BUFF-4
Q451	SIRCS SW-2	Q755	B BUFF-5
Q452	SIRCS SW-3	Q756	B BUFF-6
Q453	SIRCS SW-4	Q757	B BUFF-7
Q454	SIRCS SW-5	Q800	MODE BUFF.
Q456	SIRCS SW-6		
Q457	SIRCS SW-7		
Q458	VIDEO BUFF.	D401	+12V PROT.
Q459	VIDEO BUFF.	D402	-12V PROT.
Q460	VIDEO BUFF.	D440	SIRCS OR
Q501	H. SYNC SW-1	D450	SIRCS OR
Q502	H. SYNC SW-2	D451	AUDIO PROT-1
Q503	V. SYNC SW-1	D452	LEVEL SHIFT
Q504	V. SYNC SW-2	D501	H. SYNC CLAMP
Q506	R BUFF.	D502	V. SYNC CLAMP
Q507	G BUFF.	D503	VOLTAGE PROT.
Q508	B BUFF.	D505	PROT.
Q509	VIDEO BUFF.	D506	POW CONT.
Q510	MODE SW-1	D507	H. SYNC PROT.
Q511	MODE SW-2	D508	V. SYNC PROT.
Q512	MODE SW-3	D509	R PROT-1
Q513	MODE SW-4	D510	R PROT-2
Q514	MODE SW-5	D511	G PROT-1
Q515	MODE SW-6	D512	G PROT-2
Q516	Y BUFF-1	D513	B PROT-1
Q517	C BUFF-1	D514	B PROT-2
Q520	MODE SW-7	D516	Y PROT.
Q521	MODE SW-8	D518	C PROT.
Q522	VIDEO AMP-1	D520	S SW PROT-1
Q523	VIDEO AMP-2	D521	S SW PROT-2
Q524	VIDEO BUFF-2	D522	VIDEO PROT-1
Q528	MODE SW-9	D523	VIDEO PROT-2
Q529	MODE SW-10	D524	HD SEL PROT.
Q530	MODE SW-11	D525	LEVEL SHIFT
Q531	MODE SW-12	D526	MODE SW-1
Q534	MODE SW-13	D527	SUB 5V PROT.
Q535	MODE SW-14	D528	MODE SW-2
Q536	MODE SW-15	D529	LEVEL SHIFT
Q537	MODE SW-16	D531	PROT.
Q538	MODE SW-17	D532	PROT.
Q539	MODE SW-17	D533	PROT.
Q540	MODE SW-18	D534	PROT.
Q541	MODE SW-19	D634	MODE OR-1
Q542	MODE SW-20	D652	MODE OR-2
Q543	MODE SW-21	D653	MODE OR-3

SCHEMATIC DIAGRAMS AND PRINTED WIRING BOARDS

BB/BD BOARD

The following diagrams has been devided into 3 sections as noted on the grid shown below.

A1	A2	A3
----	----	----

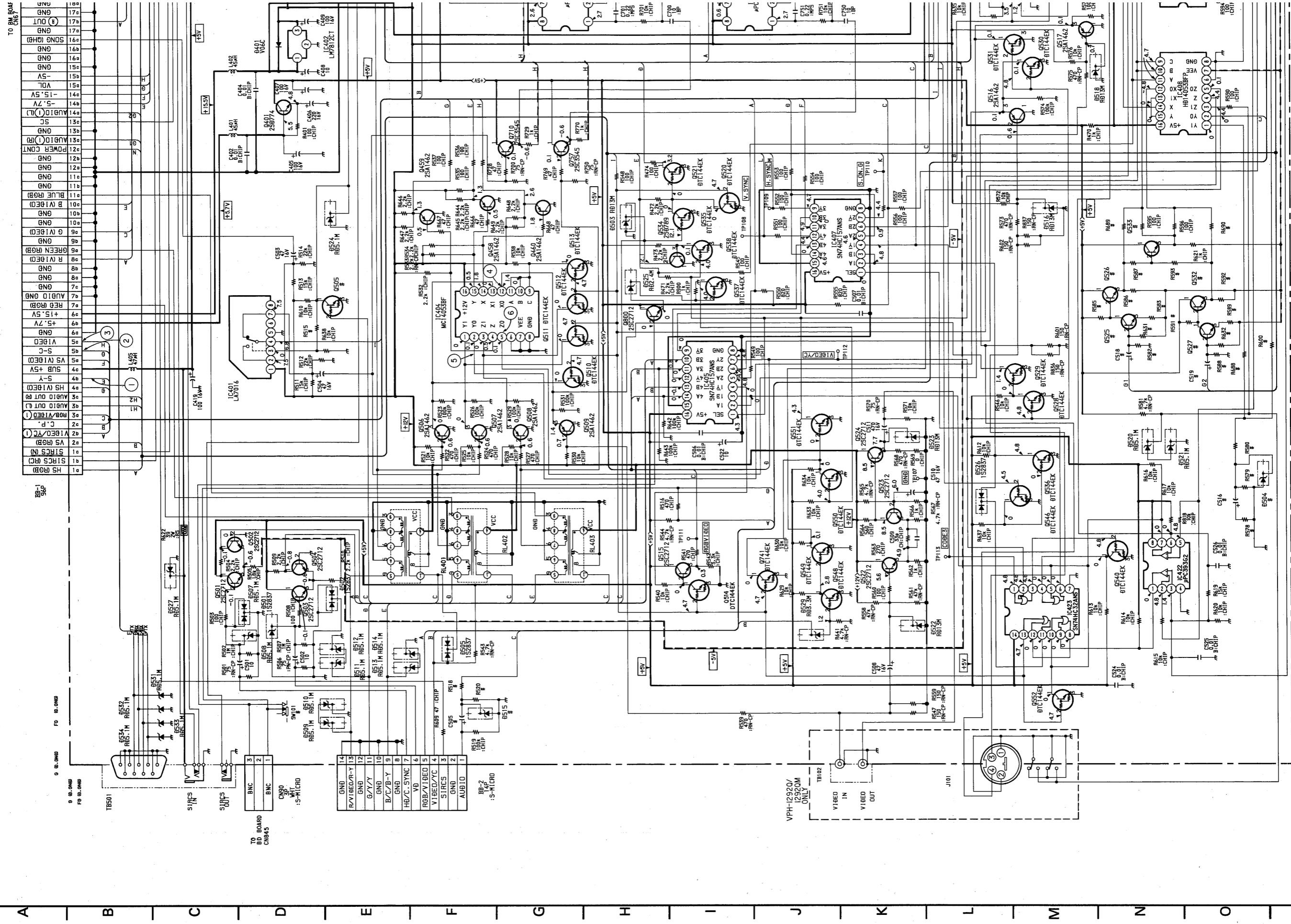

TO RM BOARD

322	SELECT
321	AUDIO GND
319	B. CHA
318	G. CHA
317	G. CHA
316	B. CHA
315	R. CHA
314	C. BRT
313	BOARDER
312	BOARDER
311	C. BRT
310	SG
309	SG
308	NOR. TEST
307	PH
306	HS (BB. Y)
305	VS (BB. Y)
304	SONG
303	ROB/VIDEO (2)
302	TRI/NOT
301	CLEAR BLUE
300	GND
299	SIGRS (BB)
298	VINSELECT
297	TX
296	HCON
295	HVSSEL
294	TX
293	RX
292	RCONZ
291	GND
290	GND
289	GND
288	GND
287	GND
286	GND
285	GND
284	GND
283	GND
282	GND
281	GND
280	GND
279	GND
278	GND
277	GND
276	GND
275	GND
274	GND
273	GND
272	GND
271	GND
270	GND
269	GND
268	GND
267	GND
266	GND
265	GND
264	GND
263	GND
262	GND
261	GND
260	GND
259	GND
258	GND
257	GND
256	GND
255	GND
254	GND
253	GND
252	GND
251	GND
250	GND
249	GND
248	GND
247	GND
246	GND
245	GND
244	GND
243	GND
242	GND
241	GND
240	GND
239	GND
238	GND
237	GND
236	GND
235	GND
234	GND
233	GND
232	GND
231	GND
230	GND
229	GND
228	GND
227	GND
226	GND
225	GND
224	GND
223	GND
222	GND
221	GND
220	GND
219	GND
218	GND
217	GND
216	GND
215	GND
214	GND
213	GND
212	GND
211	GND
210	GND
209	GND
208	GND
207	GND
206	GND
205	GND
204	GND
203	GND
202	GND
201	GND
200	GND
199	GND
198	GND
197	GND
196	GND
195	GND
194	GND
193	GND
192	GND
191	GND
190	GND
189	GND
188	GND
187	GND
186	GND
185	GND
184	GND
183	GND
182	GND
181	GND
180	GND
179	GND
178	GND
177	GND
176	GND
175	GND
174	GND
173	GND
172	GND
171	GND
170	GND
169	GND
168	GND
167	GND
166	GND
165	GND
164	GND
163	GND
162	GND
161	GND
160	GND
159	GND
158	GND
157	GND
156	GND
155	GND
154	GND
153	GND
152	GND
151	GND
150	GND
149	GND
148	GND
147	GND
146	GND
145	GND
144	GND
143	GND
142	GND
141	GND
140	GND
139	GND
138	GND
137	GND
136	GND
135	GND
134	GND
133	GND
132	GND
131	GND
130	GND
129	GND
128	GND
127	GND
126	GND
125	GND
124	GND
123	GND
122	GND
121	GND
120	GND
119	GND
118	GND
117	GND
116	GND
115	GND
114	GND
113	GND
112	GND
111	GND
110	GND
109	GND
108	GND
107	GND
106	GND
105	GND
104	GND
103	GND
102	GND
101	GND
100	GND
99	GND
98	GND
97	GND
96	GND
95	GND
94	GND
93	GND
92	GND
91	GND
90	GND
89	GND
88	GND
87	GND
86	GND
85	GND
84	GND
83	GND
82	GND
81	GND
80	GND
79	GND
78	GND
77	GND
76	GND
75	GND
74	GND
73	GND
72	GND
71	GND
70	GND
69	GND
68	GND
67	GND
66	GND
65	GND
64	GND
63	GND
62	GND
61	GND

NOTE) H. SYNC (....) — H.S. (...)
V. SYNC (....) — V.S. (...)

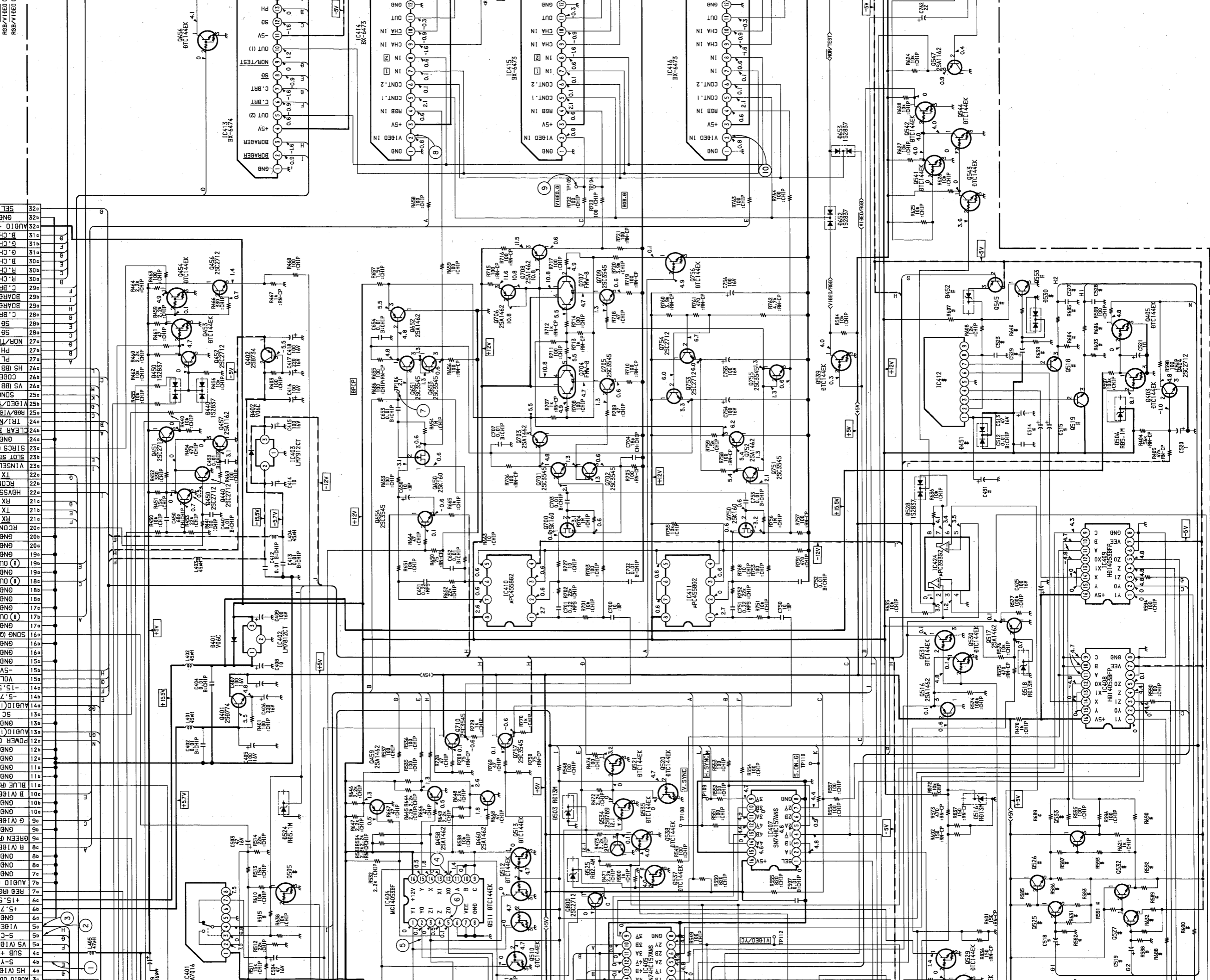

Schematic diagrams
← BB, BD boards

(NOTE) H-SYNC (.....) H-S. (.....) V-BED/TC (IF. BB) V-BED/TC (BB. Y) V-BED/TC (BB. Y) V-BED/TC (BB. Y) V-S. (.....) V-S. (.....) RBB/VIBED (IF. BB) RBB/VIBED (BB. Y) RBB/VIBED (BB. Y) RBB/VIBED (BB. Y)

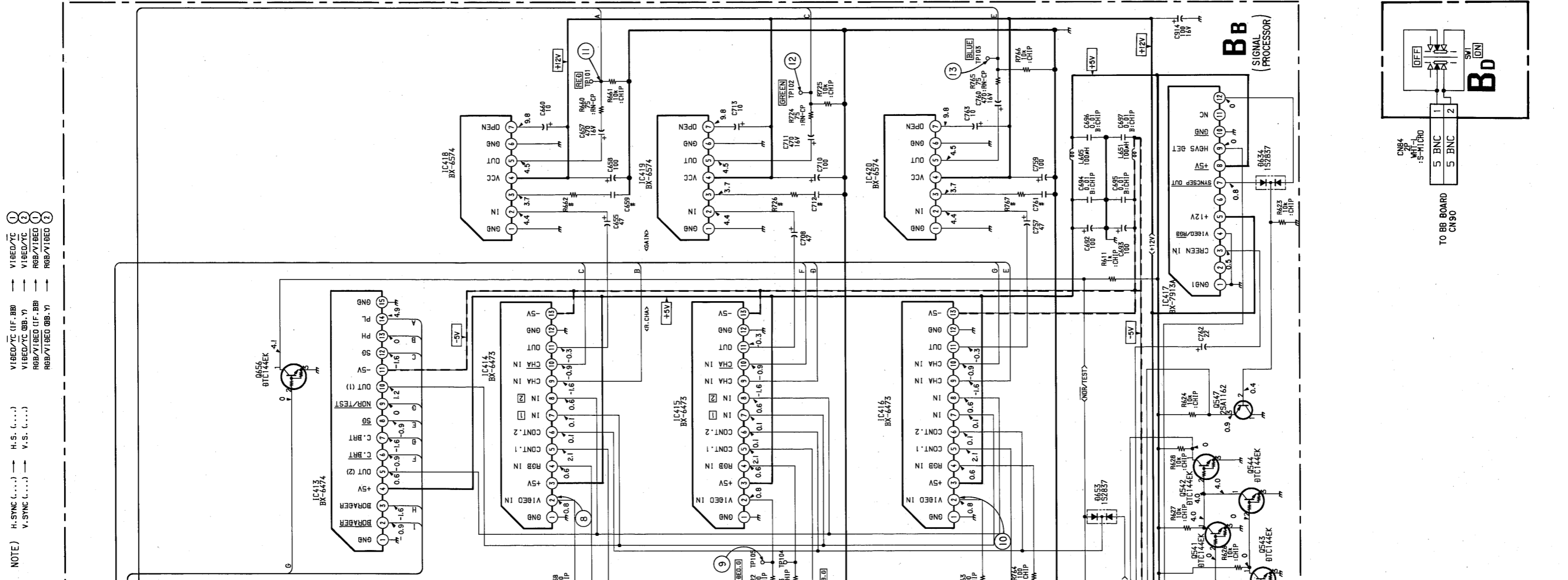
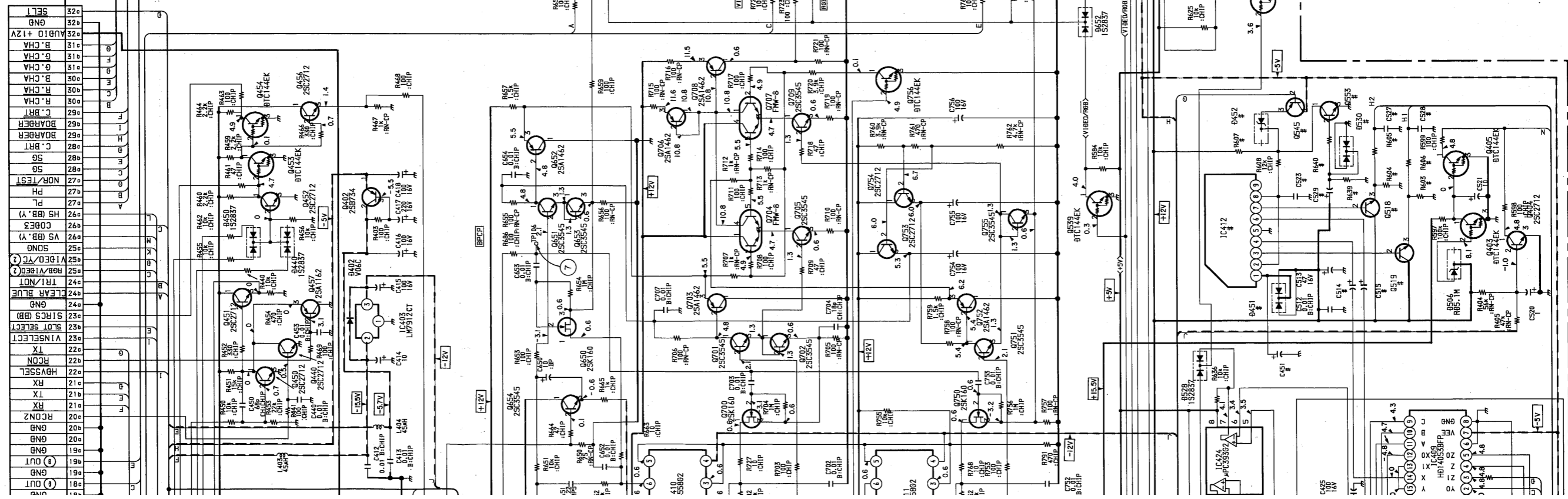

Schematic diagrams

Schematic diagram

SCHEMATIC DIAGRAMS AND PRINTED WIRING BOARDS

BM BOARD

The following diagram has been divided into 3 sections as noted on the grid shown below.

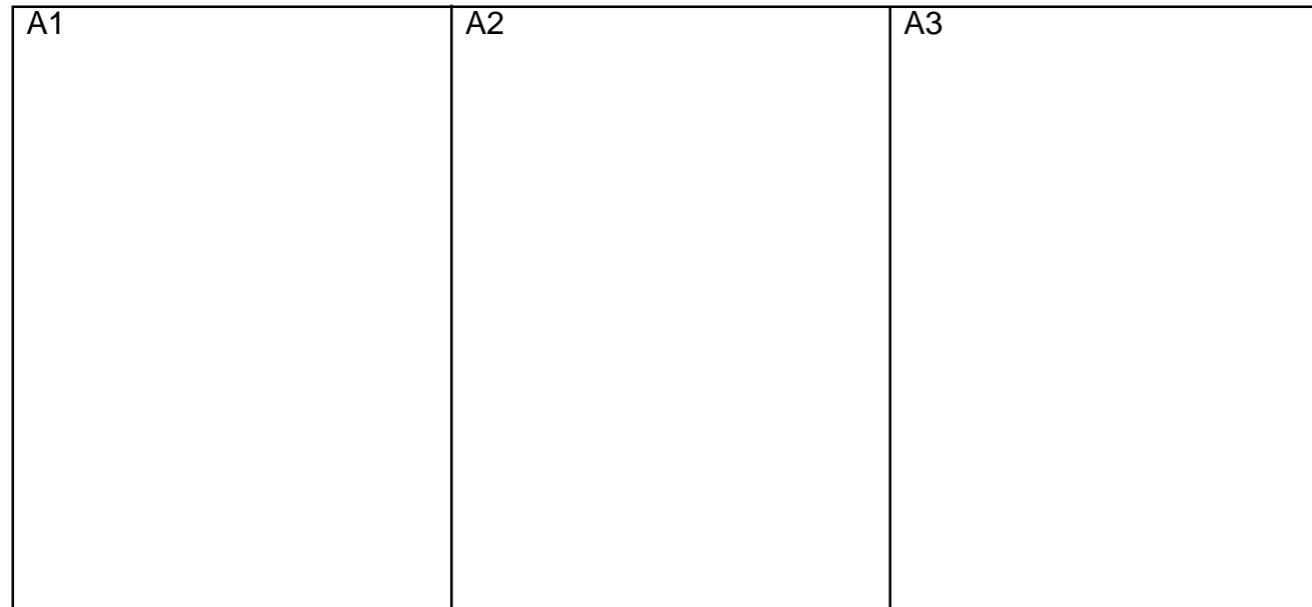

A1 1 2 3 4 5 6 7 8 9 10 11 A B C D E F G H I J K L M N O P

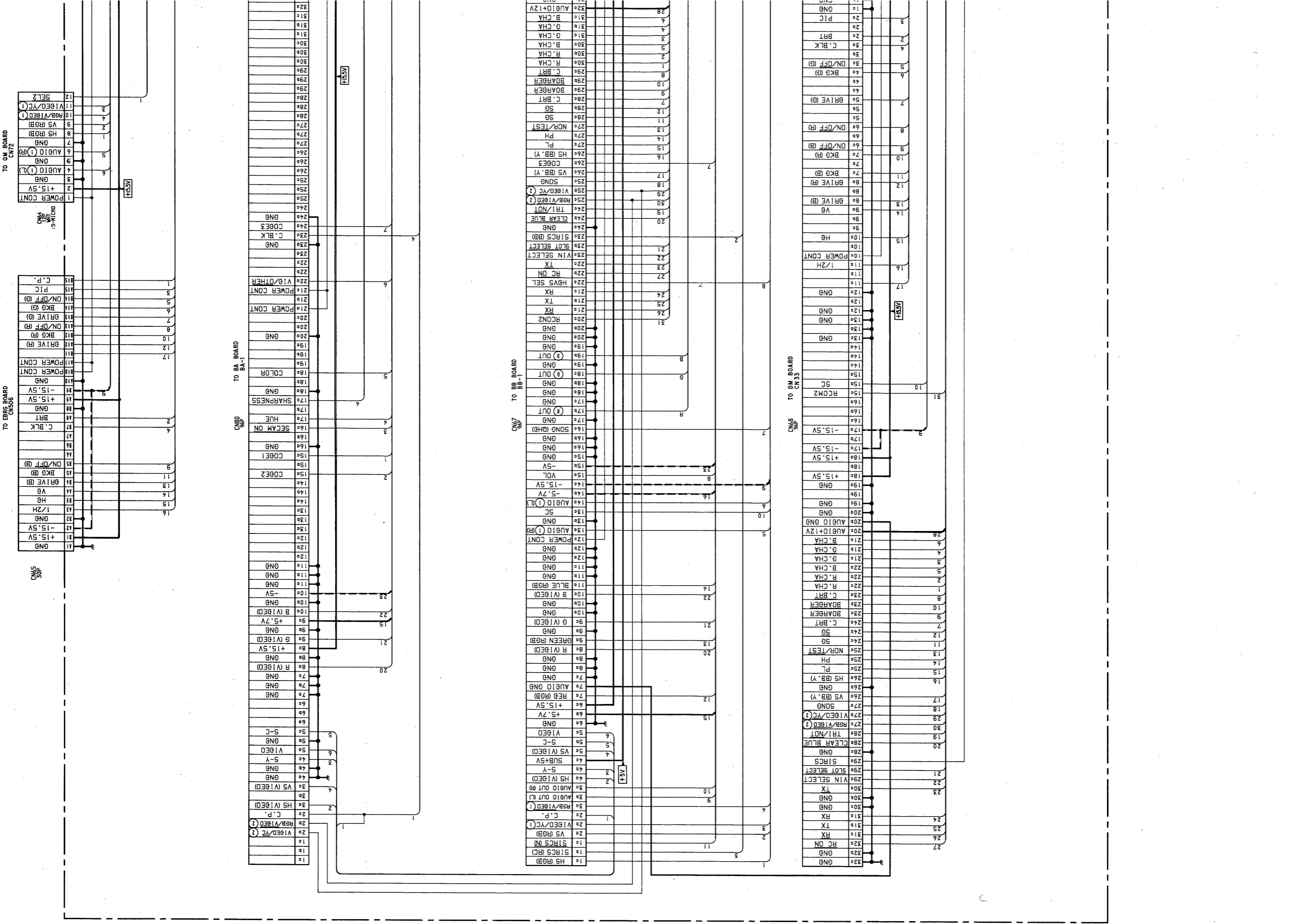

A2 7 8 9 10 11 12 13 14 15 16 17 18

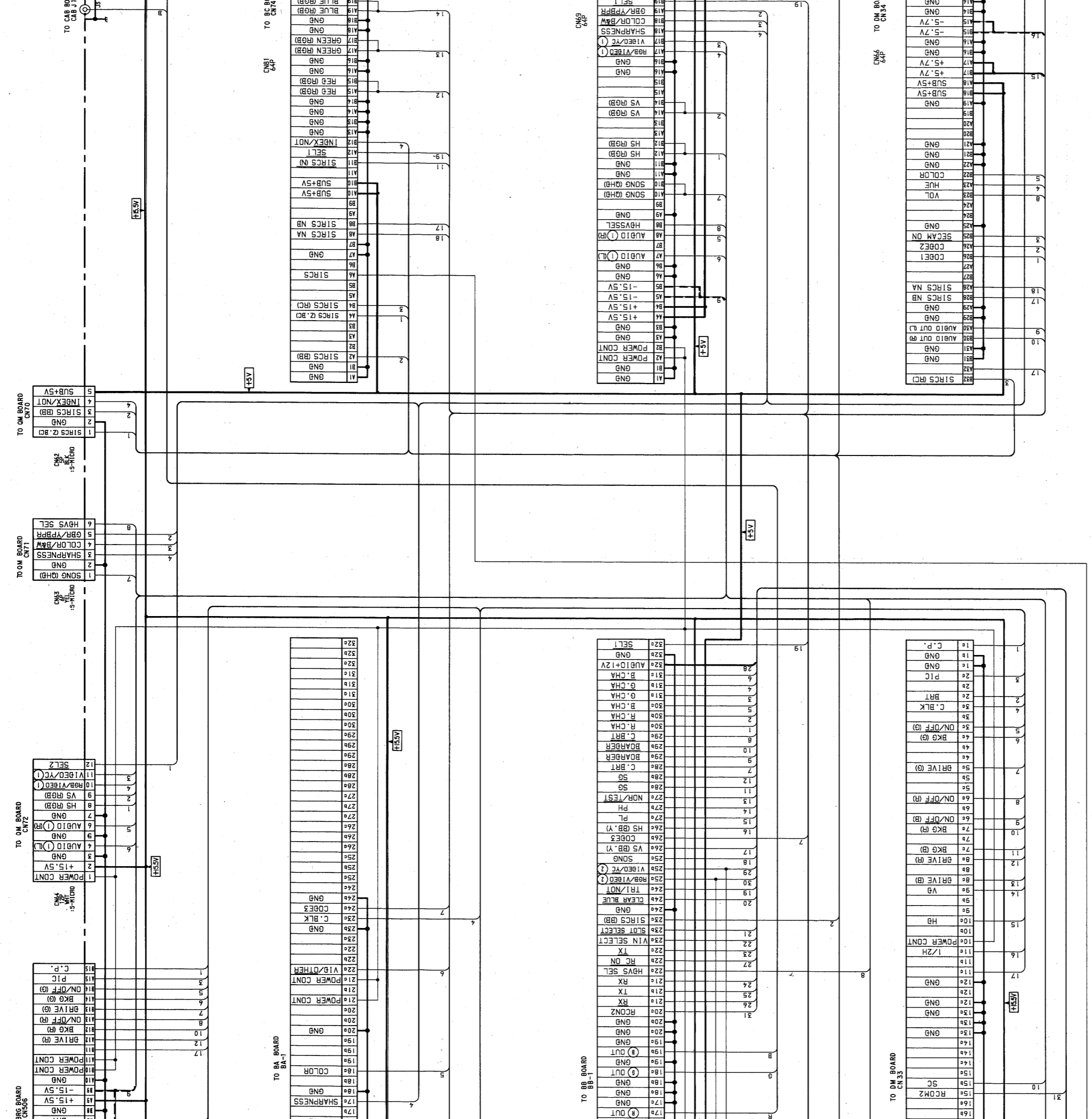

BM (MOTHER)

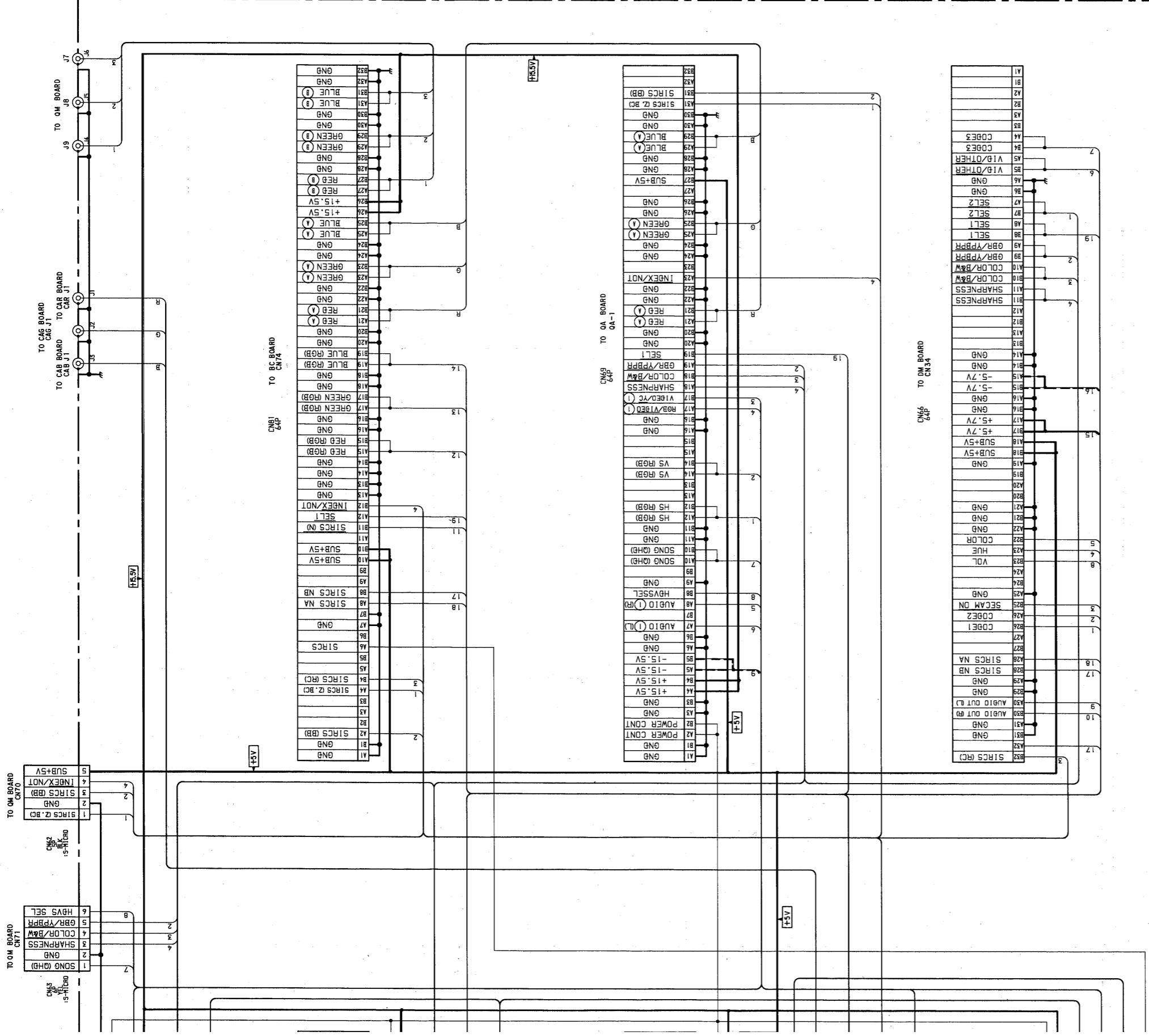

BM (MOTHER)

BM [MOTHER]

- BM BOARD -

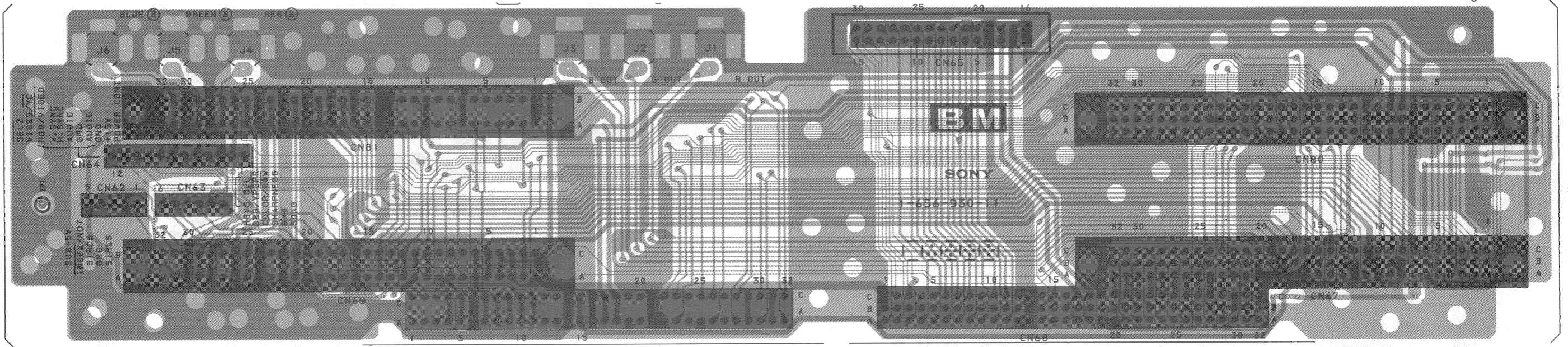

- [Pattern from the side which enables seeing.]
- [Pattern of the rear side.]

BC

[SIGNAL SWITCH]

L

[ERROR CODE DISPLAY]

QM

[MOTHER]

- BC BOARD -

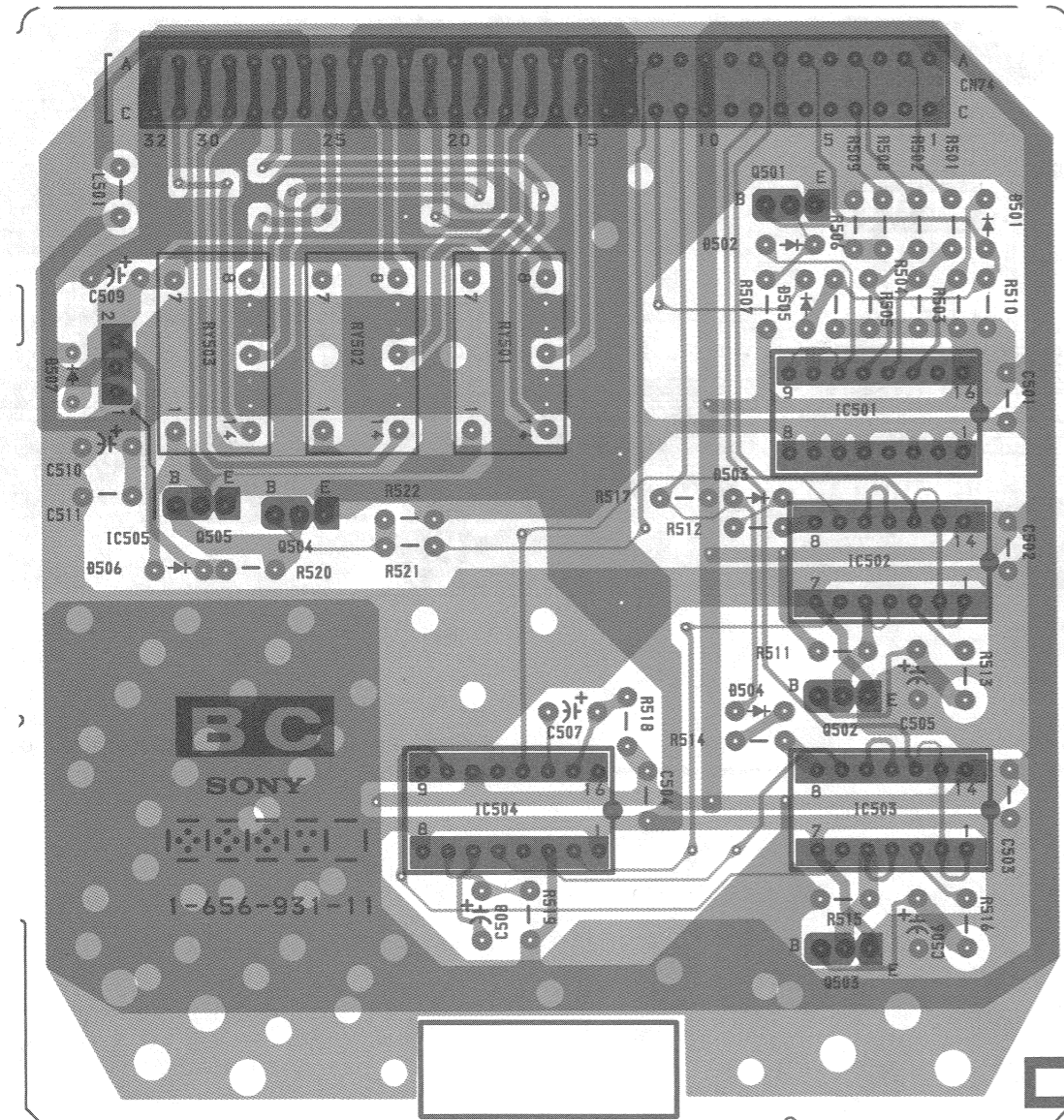

- : Pattern from the side which enables seeing.
- : Pattern of the rear side.

- L BOARD -

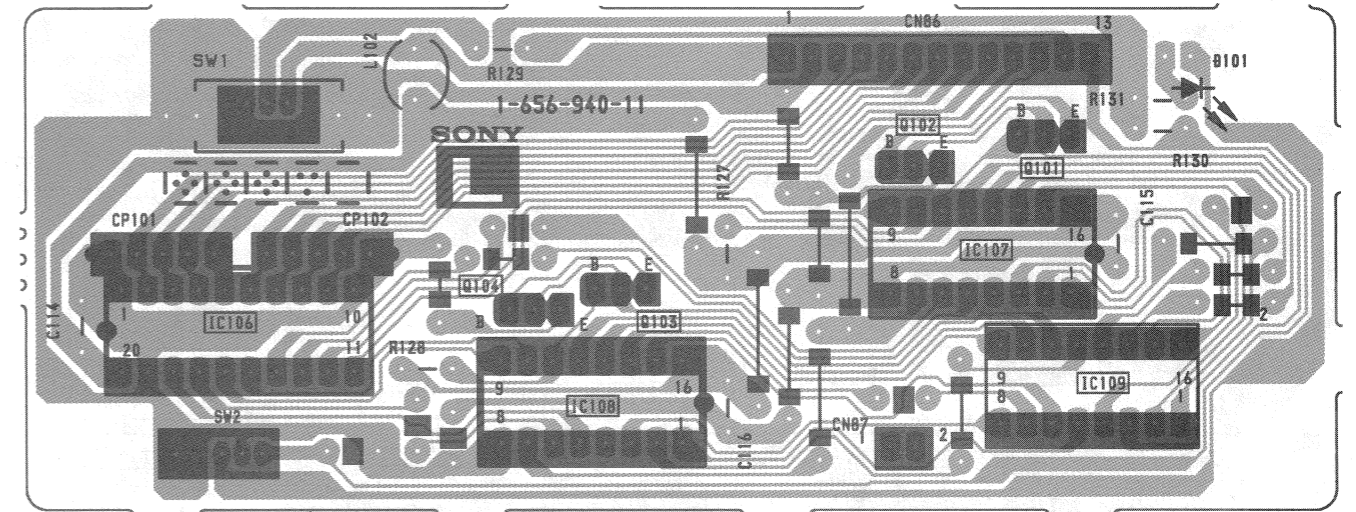

- QM BOARD -

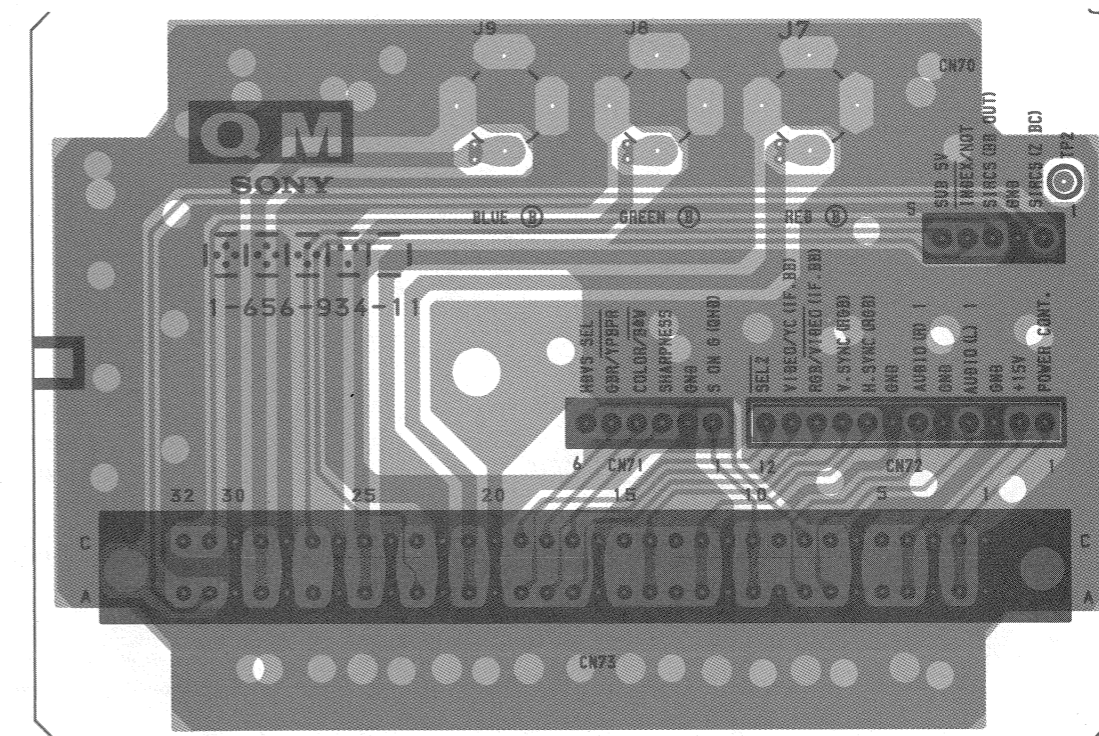

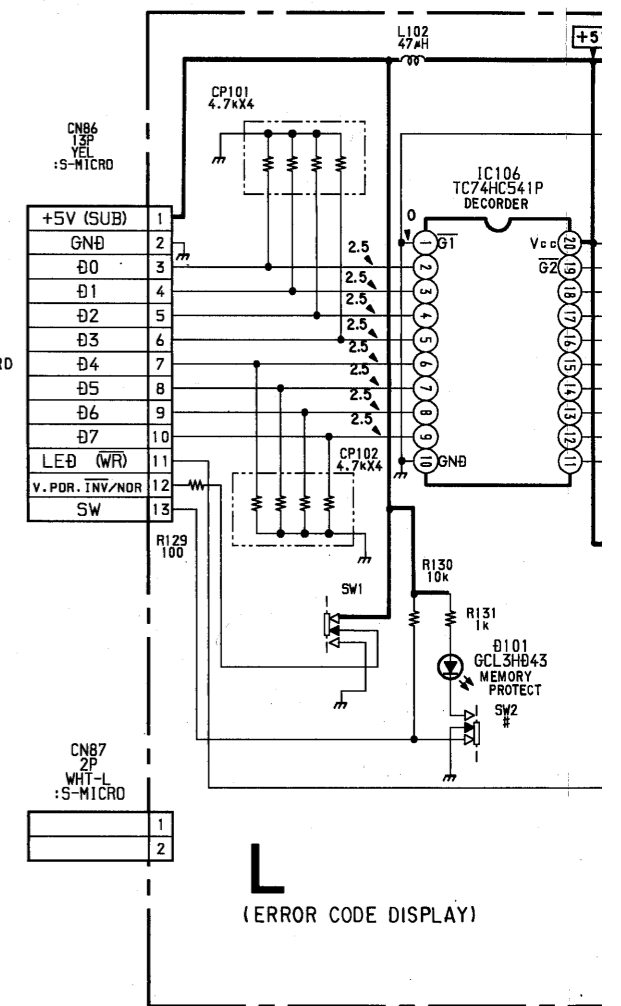
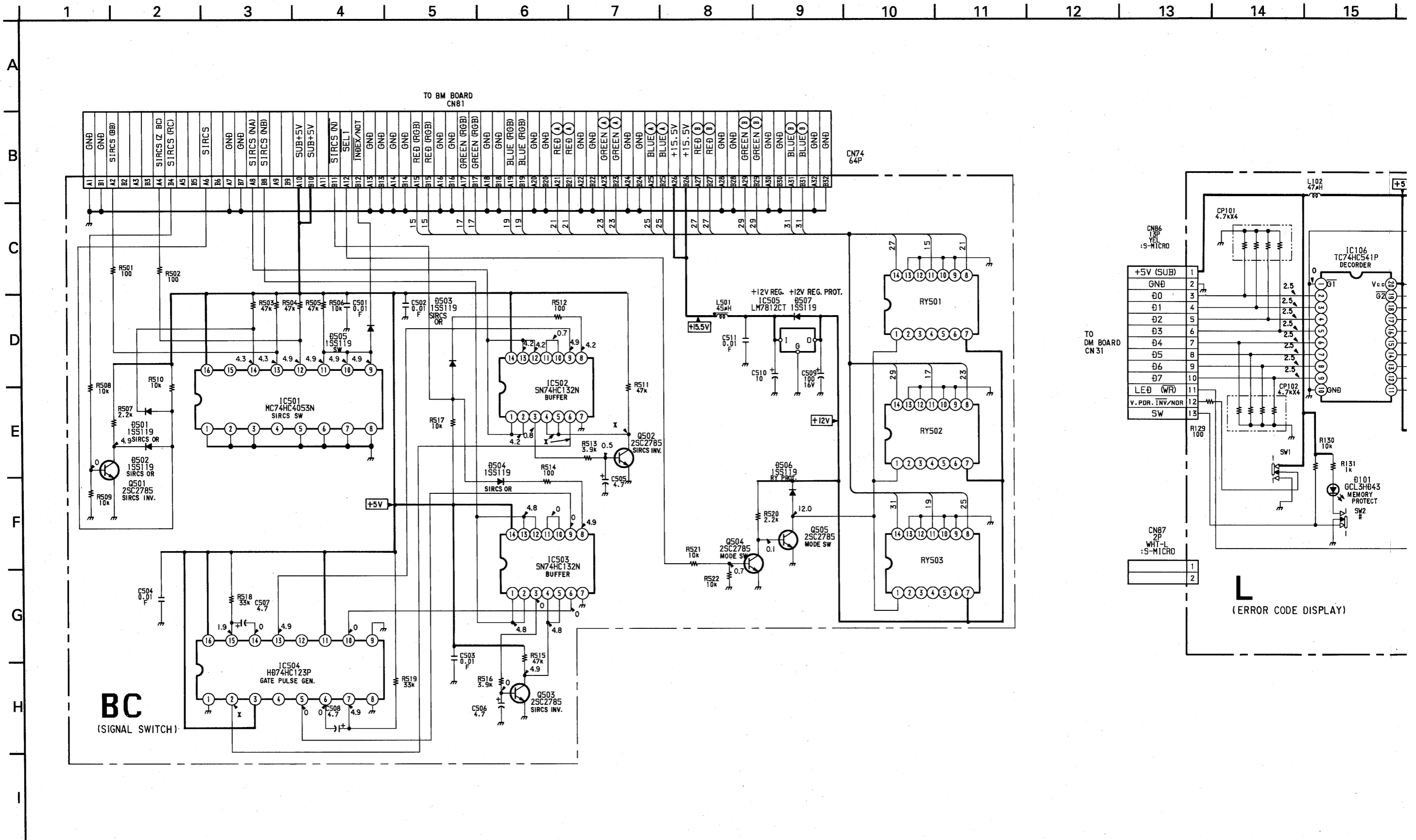

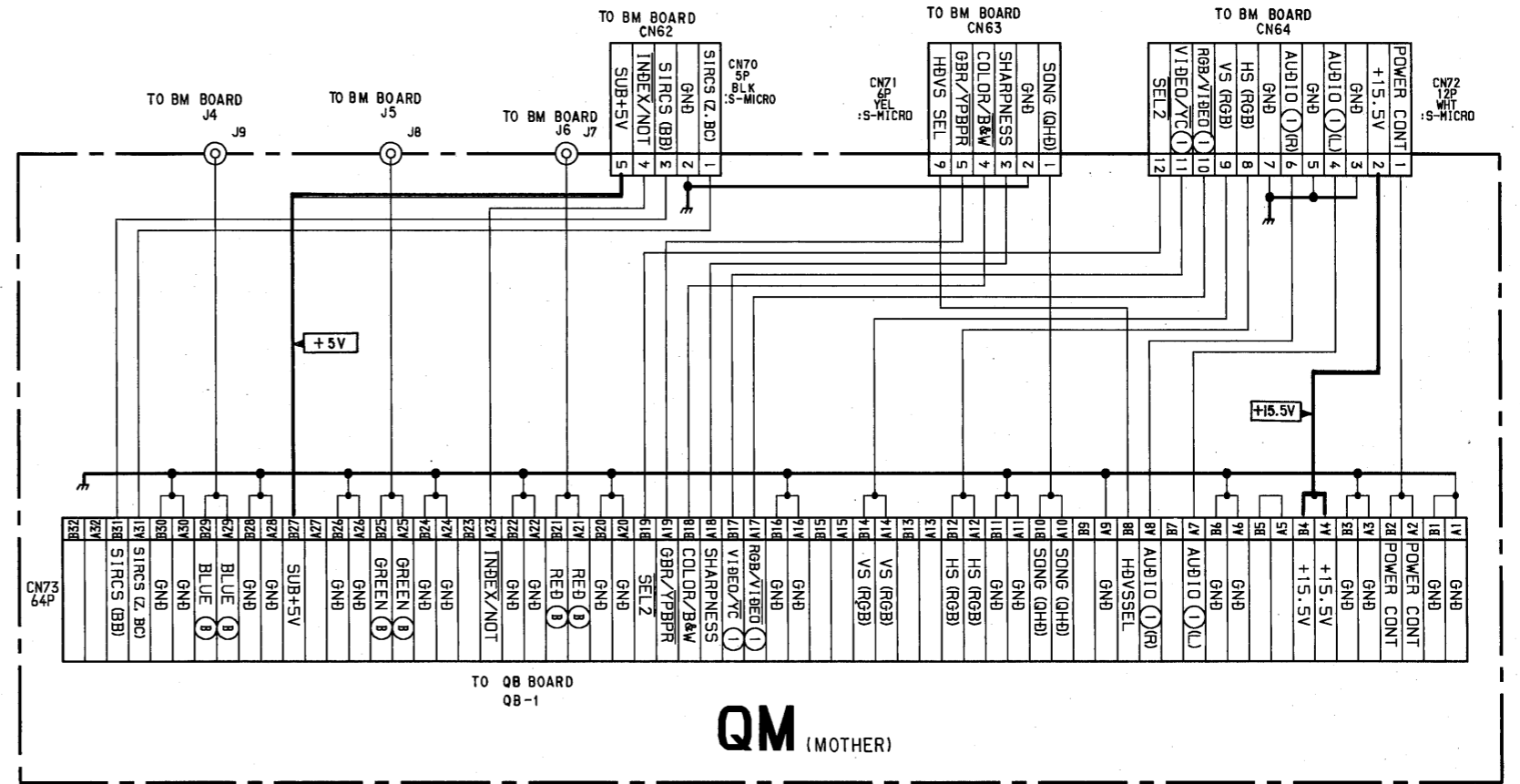
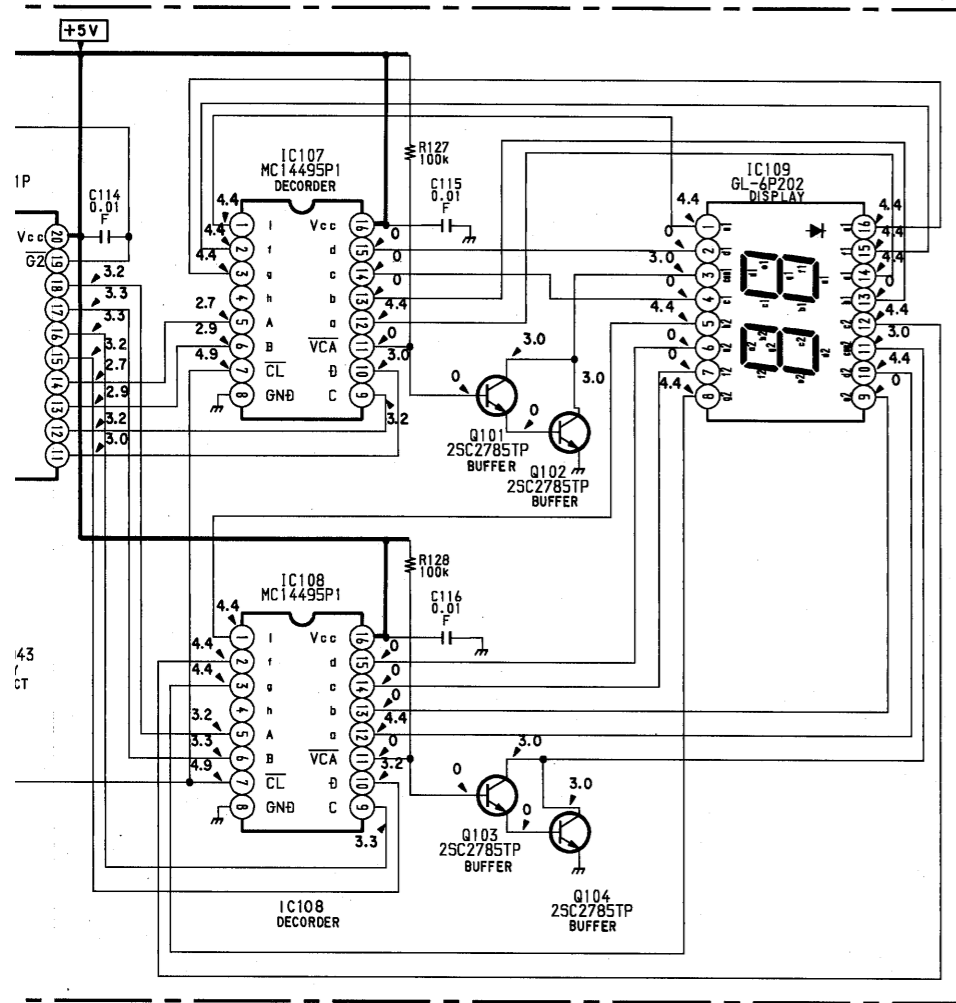

L BOARD IC106 TC74HC541P

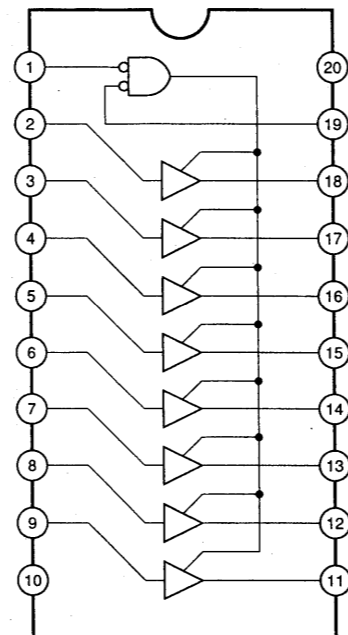

DA

[AFC/V. HOLD/WAVEFORM GENERATOR]

- DA BOARD - <Component Side>

**DA BOARD
(COMPONENT SIDE)**

IC	Q204 B-8	Q205 D-9	Q207 C-9	Q209 D-9	Q211 D-9	Q213 C-9	Q215 B-9	Q217 B-9	Q219 C-9	Q403 A-8	Q404 A-9	Q501 B-5	Q701 D-8	Q702 E-8	Q703 D-7	Q704 D-7	Q705 D-8	Q706 D-7	Q709 A-6														
IC1 A-3	IC2 A-1	IC4 E-3	IC6 D-3	IC7 D-9	IC9 C-3	IC11 B-5	IC12 D-2	IC14 D-2	IC15 E-7	IC16 B-2	IC17 D-8	IC18 C-3	IC20 C-2	IC21 C-2	IC22 B-2	IC23 A-1	IC24 A-1	IC201 C-8	IC202 A-8	IC203 D-8	IC204 C-7	IC205 B-7	IC206 D-9	IC207 B-7	IC208 A-7	IC209 D-7	IC210 C-8	IC211 D-10	IC401 A-9	IC402 A-8	IC601 E-8	IC801 E-2	IC802 B-4
	DIODE																																
	D1 A-3	D2 A-1	D3 D-3	D4 B-5	D5 D-3	D6 B-5	D9 B-4	D10 C-2	D20 D-3	D401 A-9	D402 A-9	D701 D-7	D801 E-2	D802 B-4																			
	VARIABLE RESISTOR																																
	RV1 E-3	RV2 E-4	RV3 E-4	RV4 E-4	RV5 E-4	RV6 B-1	RV7 E-3																										
TRANSISTOR	Q4 D-2	Q9 B-5	Q16 D-7	Q19 B-2	Q20 B-2	Q31 D-1	Q32 C-1	Q35 B-3																									

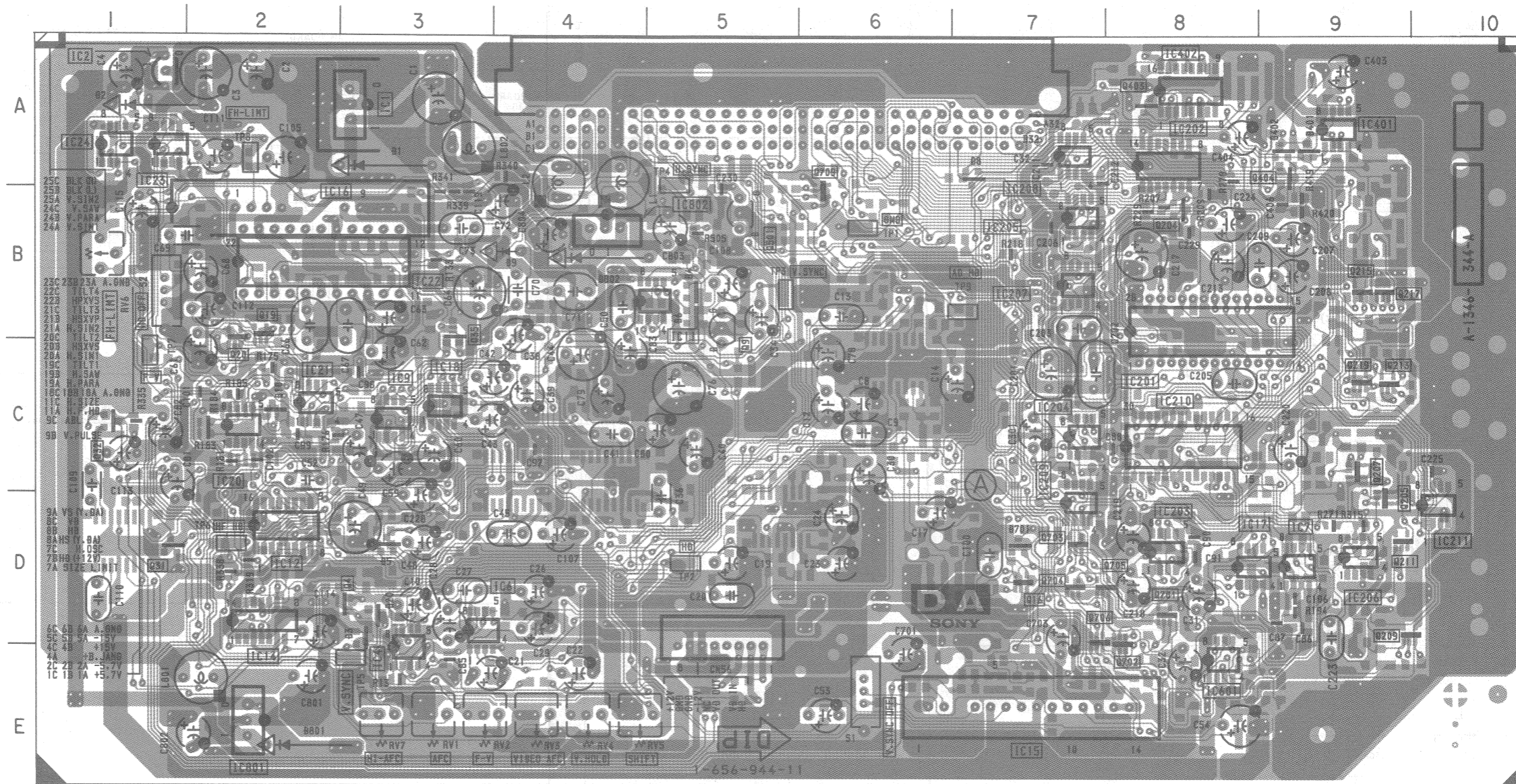

<Conductor Side>

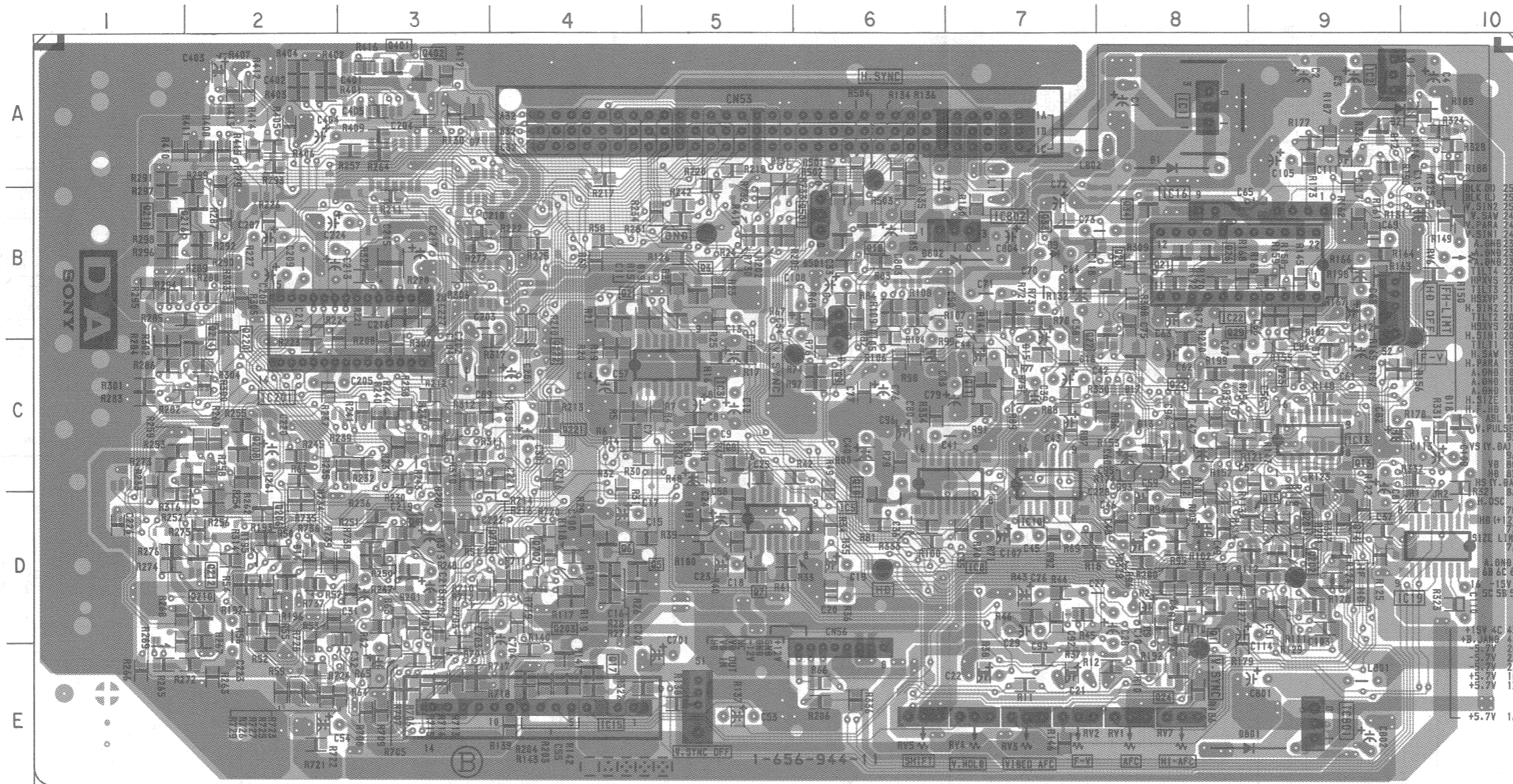

DA BOARD
(CONDUCTOR SIDE)

IC		D203	E-4
IC1	A-8	D206	D-2
IC2	A-9	D208	C-2
IC3	C-5	D210	D-2
IC5	D-5	D212	D-2
IC8	C-7	D214	C-2
IC10	C-7	D216	B-2
IC13	C-9	D218	B-1
IC15	E-4	D220	B-2
IC16	B-8	D221	C-4
IC19	D-10	D222	C-4
IC22	B-8	D401	A-3
IC201	C-2	D402	A-3
IC801	E-9	D501	B-6
IC802	B-7	D707	D-4
		D708	D-4
TRANSISTOR		DIODE	
Q1	D-8	D1	A-8
Q2	B-4	D2	A-9
Q3	B-5	D7	A-3
D5	D-5	D9	B-7
D6	D-4	D11	C-9
D7	D-5	D12	A-9
D8	C-5	D13	C-8
D9	B-6	D14	D-2
D10	C-6	D15	C-7
D11	C-7	D16	C-7
D12	D-8	D17	C-8
D13	C-9	D18	C-10
D14	D-9	D19	B-5
D15	D-9	D201	D-3
D17	E-4	D501	B-6
D18	B-6	D801	E-9
D21	B-8	D802	B-7
D22	C-8	VARIABLE RESISTOR	
D24	E-8	RV1	E-8
D25	C-9	RV2	E-7
D26	B-8	RV3	E-7
D27	C-8	RV4	E-7
D28	B-8	RV5	E-6
D29	C-8	RV6	B-10
D33	B-7	RV7	E-8
D34	B-8		
D201	D-9		
D202	D-9		

- : Pattern from the side which enables seeing.
- : Pattern of the rear side.

SCHEMATIC DIAGRAMS AND PRINTED WIRING BOARDS

DA BOARD

The following diagram has been divided into 3 sections as noted on the grid shown below.

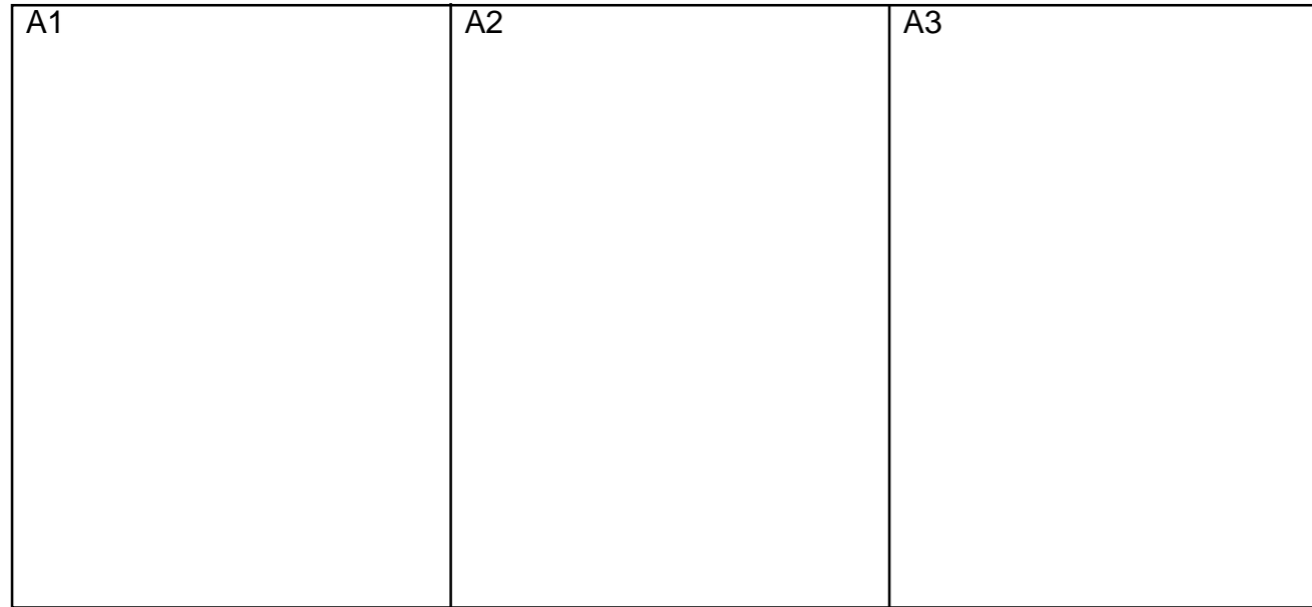

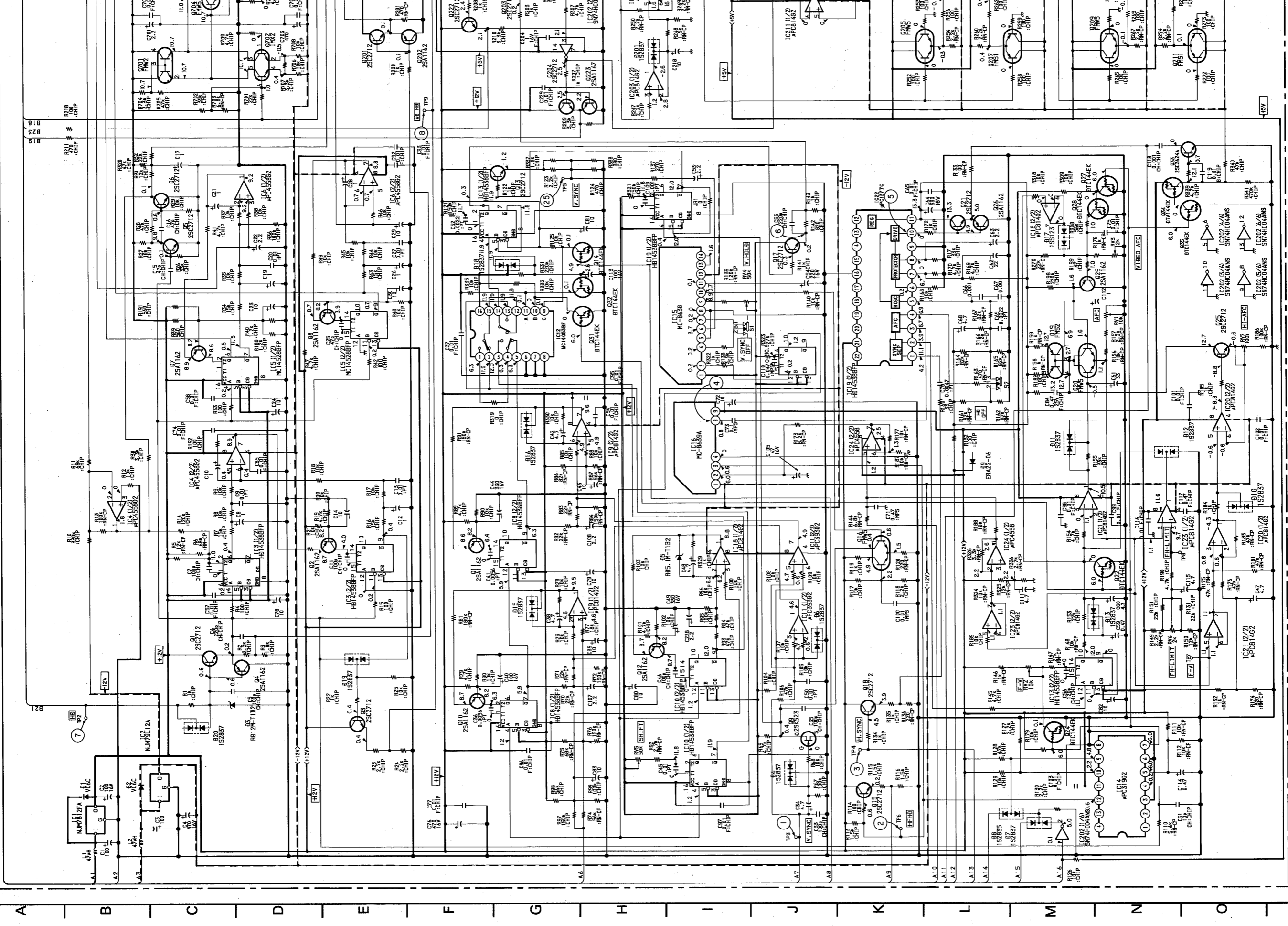

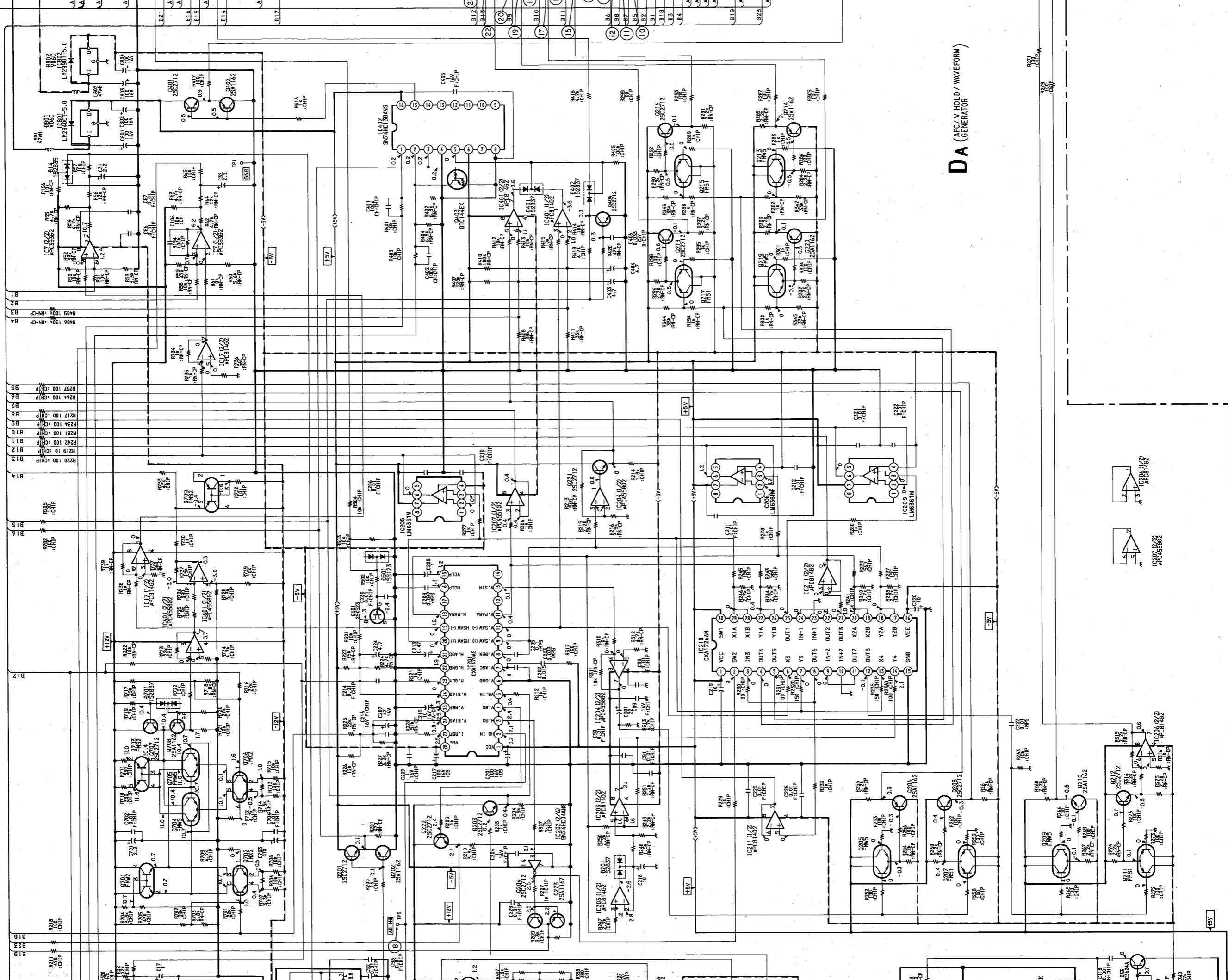

DA (AFC/V HOLD / WAVEFORM) GENERATOR

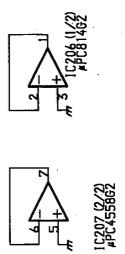

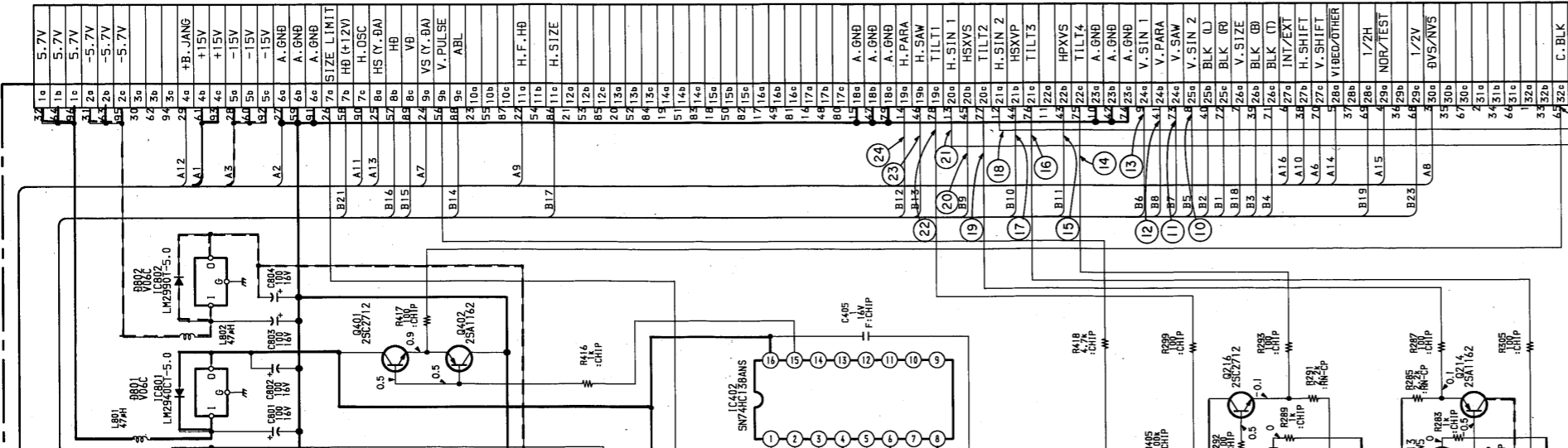

TO DM BOARD CNZ

DA BOARD

IC1	+12V REG.	Q32	SW5
IC2	-12V REG. <td>Q33</td> <td>SWITCH</td>	Q33	SWITCH
IC3	AD HD GEN. <td>Q34</td> <td>INVERTOR</td>	Q34	INVERTOR
IC4	AD HD COMP. <td>Q35</td> <td>INVERTOR</td>	Q35	INVERTOR
IC5	H. BLK GEN. <td>Q201</td> <td>H. D BUFF-3</td>	Q201	H. D BUFF-3
IC6	H. BLK COMP. <td>Q202</td> <td>H. D BUFF-4</td>	Q202	H. D BUFF-4
IC7	H. BLK LEVEL DET. <td>Q203</td> <td>VD BUFF-2</td>	Q203	VD BUFF-2
IC8	D. V. SHIFT GEN. <td>Q204</td> <td>1/2 H. BUFF. </td>	Q204	1/2 H. BUFF.
IC9	D. V. SHIFT CLAMP <td>Q205</td> <td>V. SIN 1 SW</td>	Q205	V. SIN 1 SW
IC10	V. SHIFT GEN. <td>Q206</td> <td>V. SIN 1 BUFF. </td>	Q206	V. SIN 1 BUFF.
IC11	D. V. SHIFT PROT. <td>Q207</td> <td>V. SIN 2 SW</td>	Q207	V. SIN 2 SW
IC12	V. SHIFT SW <td>Q208</td> <td>V. SIN 2 BUFF. </td>	Q208	V. SIN 2 BUFF.
IC13	PULSE GEN. <td>Q209</td> <td>H. SIN 1 SW</td>	Q209	H. SIN 1 SW
IC14	HF HD COMP. <td>Q210</td> <td>H. SIN 1 BUFF. </td>	Q210	H. SIN 1 BUFF.
IC15	V. HOLD <td>Q211</td> <td>H. SIN 2 SW</td>	Q211	H. SIN 2 SW
IC16	H. SHIFT <td>Q212</td> <td>H. SIN 2 BUFF. </td>	Q212	H. SIN 2 BUFF.
IC17	H. SAW AMP <td>Q213</td> <td>TILT 2 SW</td>	Q213	TILT 2 SW
IC18	V. SHIFT CLAMP <td>Q214</td> <td>TILT 2 BUFF. </td>	Q214	TILT 2 BUFF.
IC19	VD GEN. <td>Q215</td> <td>TILT 4 SW</td>	Q215	TILT 4 SW
IC20	HF AFC AMP <td>Q216</td> <td>TILT 4 BUFF. </td>	Q216	TILT 4 BUFF.
IC21	F-V BUFF. <td>Q217</td> <td>TILT 1 SW</td>	Q217	TILT 1 SW
IC22	AFC <td>Q218</td> <td>TILT 1 BUFF. </td>	Q218	TILT 1 BUFF.
IC23	FH LIMIT COMP. <td>Q219</td> <td>TILT 3 SW</td>	Q219	TILT 3 SW
IC24	LEVEL SHIFT <td>Q220</td> <td>TILT 3 BUFF. </td>	Q220	TILT 3 BUFF.
IC201	WAVE FORM GEN. <td>Q221</td> <td>V. SAW BUFF. </td>	Q221	V. SAW BUFF.
IC202	INV-1 <td>Q222</td> <td>1/2 H. BUFF. </td>	Q222	1/2 H. BUFF.
IC203	H. PARA AMP <td>Q223</td> <td>1/2 V. BUFF. </td>	Q223	1/2 V. BUFF.
IC204	REGI AMP <td>Q401</td> <td>BLK BUFF-1 </td>	Q401	BLK BUFF-1
IC205	H. SAW BUFF. <td>Q402</td> <td>BLK BUFF-2 </td>	Q402	BLK BUFF-2
IC206	H. SIN AMP <td>Q403</td> <td>HD SW </td>	Q403	HD SW
IC207	V. PARA BUFF. <td>Q404</td> <td>VD SW </td>	Q404	VD SW
IC208	H. PARA BUFF. <td>Q501</td> <td>BIAS-2 </td>	Q501	BIAS-2
IC209	H. SXPV BUFF. <td>Q701</td> <td>MULTIPLY-1 </td>	Q701	MULTIPLY-1
IC210	MULTIPLY <td>Q702</td> <td>MULTIPLY-2 </td>	Q702	MULTIPLY-2
IC211	REGI BUFF. <td>Q703</td> <td>MULTIPLY-3 </td>	Q703	MULTIPLY-3
IC401	V. BLK COMP. <td>Q704</td> <td>MULTIPLY-4 </td>	Q704	MULTIPLY-4
IC402	BLK MIX <td>Q705</td> <td>MULTIPLY-5 </td>	Q705	MULTIPLY-5
IC601	SIZE ABL AMP <td>Q706</td> <td>MULTIPLY-6 </td>	Q706	MULTIPLY-6
IC801	+5V REG. <td>Q707</td> <td>MULTIPLY-7 </td>	Q707	MULTIPLY-7
IC802	-5V REG. <td>Q708</td> <td>MULTIPLY-8 </td>	Q708	MULTIPLY-8
		Q709	SIZE ABL
Q1	HD BUFF-1		
Q2	V-I CONV-1	D1	REG. PROT-1
Q3	AD HD BUFF.	D2	REG. PROT-2
Q4	HD BUFF-2	D3	HD PROT
Q5	HD AMP-1	D4	V. SYNC CLAMP
Q6	HD AMP-2	D5	V. SHIFT LIMIT-3
Q7	V-I CONV-2	D6	BIAS-1
Q8	V-I CONV-3	D7	MOR/EXT SW
Q9	V. SYNC INV. <td>D8</td> <td>VIDEO SW</td>	D8	VIDEO SW
Q10	V-I CONV-4 <td>D9</td> <td>H. OUT PROT. </td>	D9	H. OUT PROT.
Q11	V-I CONV-5 <td>D10</td> <td>LIMITER-1 </td>	D10	LIMITER-1
Q12	V-I CONV-6 <td>D11</td> <td>SPEED UP-2 </td>	D11	SPEED UP-2
Q13	V. SYNC BUFF. <td>D12</td> <td>FH. LIMIT SW </td>	D12	FH. LIMIT SW
Q14	DVS SW <td>D13</td> <td>SPEED UP-3 </td>	D13	SPEED UP-3
Q15	HF HD BUFF. <td>D14</td> <td>SPEED UP-6 </td>	D14	SPEED UP-6
Q16	V. STOP PROT. <td>D15</td> <td>V. SHIFT LIMIT-1 </td>	D15	V. SHIFT LIMIT-1
Q17	VD. BUFF-1 <td>D16</td> <td>V. SHIFT LIMIT-2 </td>	D16	V. SHIFT LIMIT-2
Q18	H. SYNC BUFF. <td>D17</td> <td>LEVEL SHIFT </td>	D17	LEVEL SHIFT
Q19	CURRENT MIRROR <td>D18</td> <td>SPEED UP-4 </td>	D18	SPEED UP-4
Q20	V-I CONV-7 <td>D19</td> <td>AD HD SW </td>	D19	AD HD SW
Q21	H. OSC BUFF-1 <td>D20</td> <td>SPEED UP-1 </td>	D20	SPEED UP-1
Q22	SW1 <td>D21</td> <td>PEEK HOLD </td>	D21	PEEK HOLD
Q24	SW2 <td>D401</td> <td>V. BLK SW </td>	D401	V. BLK SW
Q25	V-I CONV-8 <td>D402</td> <td>BLK SW </td>	D402	BLK SW
Q26	H. OSC BUFF-2 <td>D501</td> <td>LIMITER-2 </td>	D501	LIMITER-2
Q27	INV-2 <td>D701</td> <td>BIAS-2 </td>	D701	BIAS-2
Q28	SW3 <td>D801</td> <td>REG. PROT-3 </td>	D801	REG. PROT-3
Q29	VIDEO AFC <td>D802</td> <td>REG. PROT-4 </td>	D802	REG. PROT-4
Q31	SW4 <td></td> <td> </td>		

DA BOARD

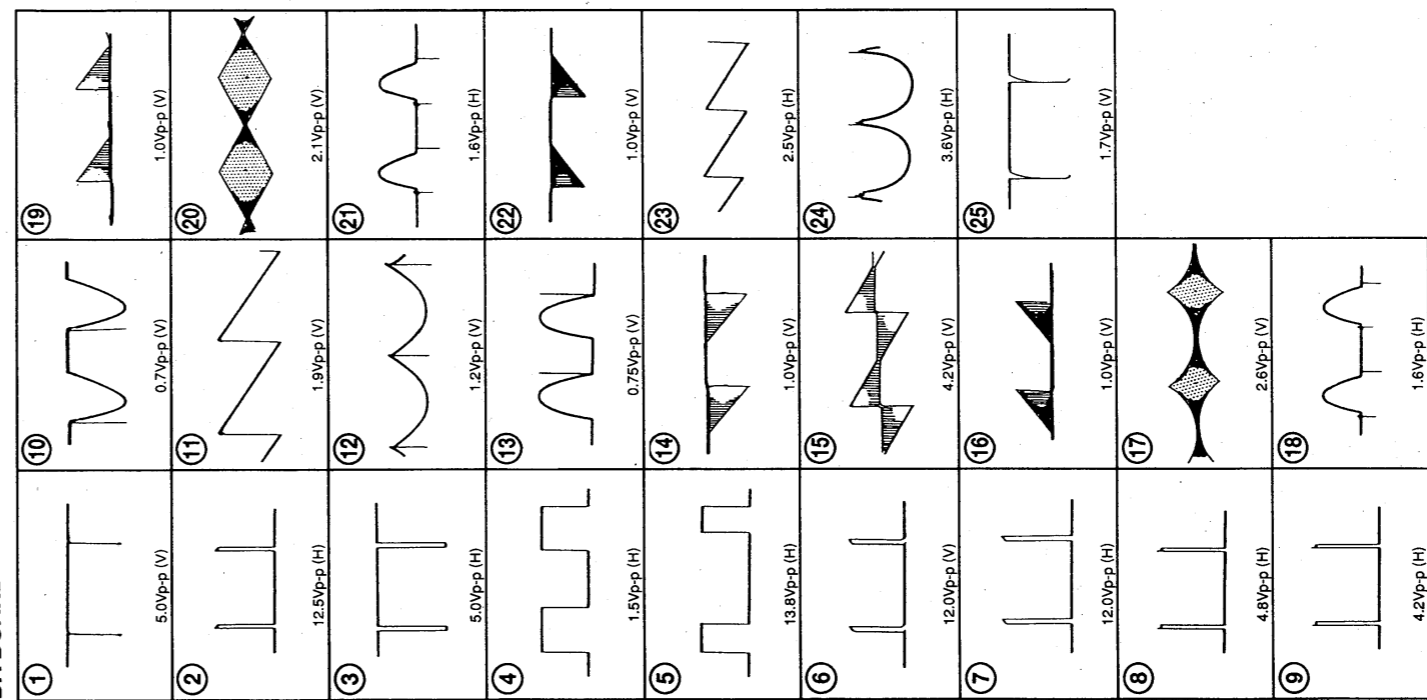

A (AFC / V HOLD / WAVEFORM) GENERATOR

SCHEMATIC DIAGRAMS AND PRINTED WIRING BOARDS

DB BOARD

The following diagram has been divided into 3 sections as noted on the grid shown below.

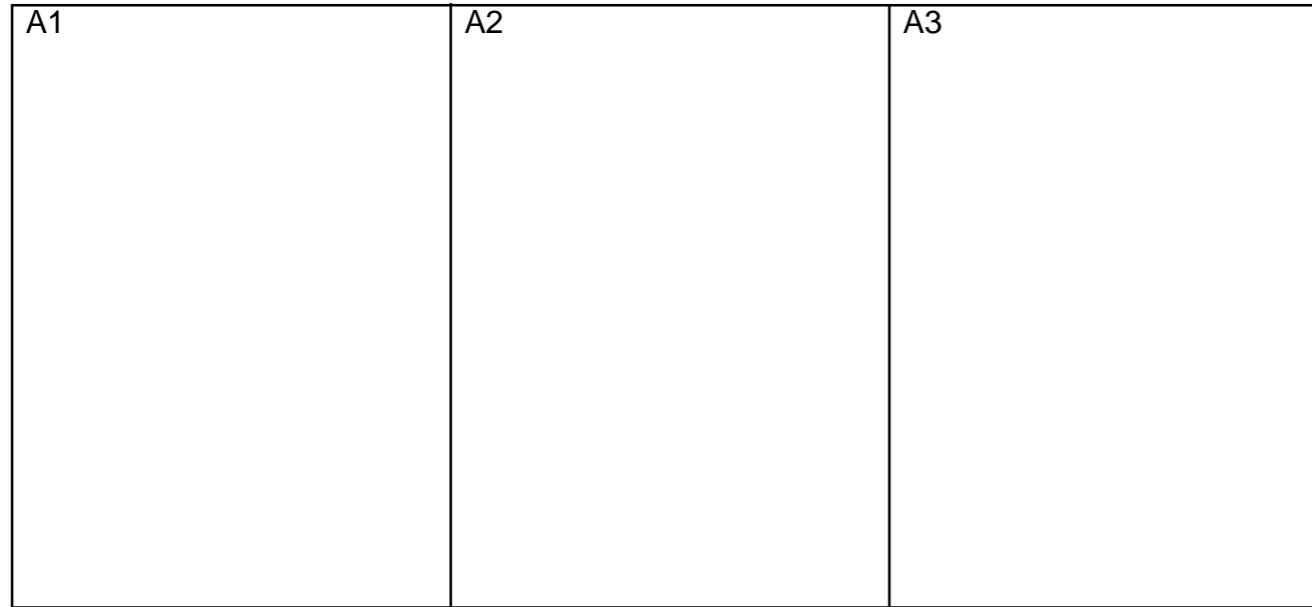

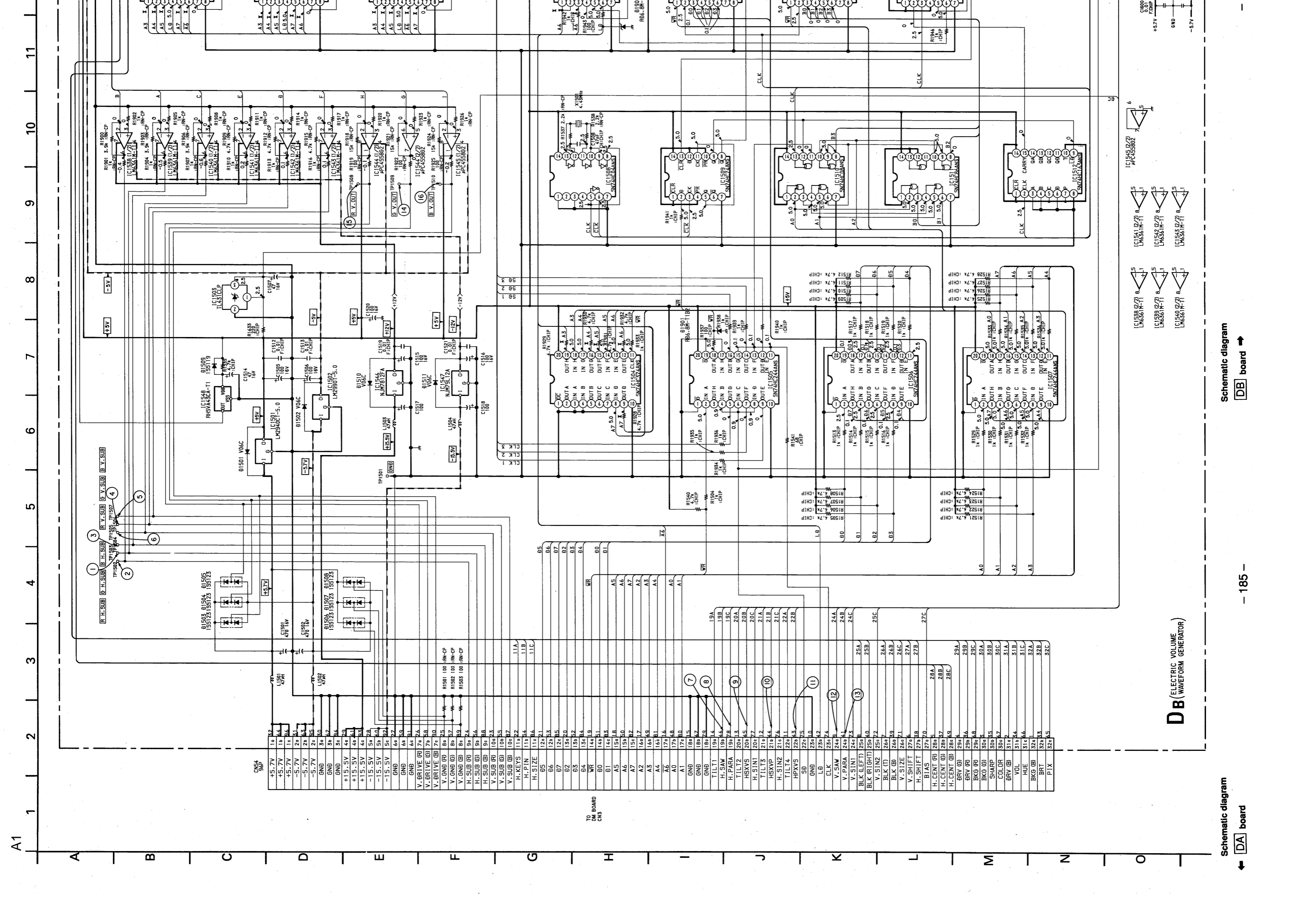

A1

1 2 3 4 5 6 7 8 9 10 11

TO BOARD CN3

DB (ELECTRIC VOLUME WAVEFORM GENERATOR)

Schematic diagram
 DB board

Schematic diagram
 DB board

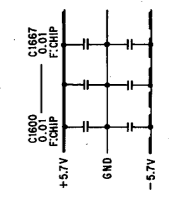
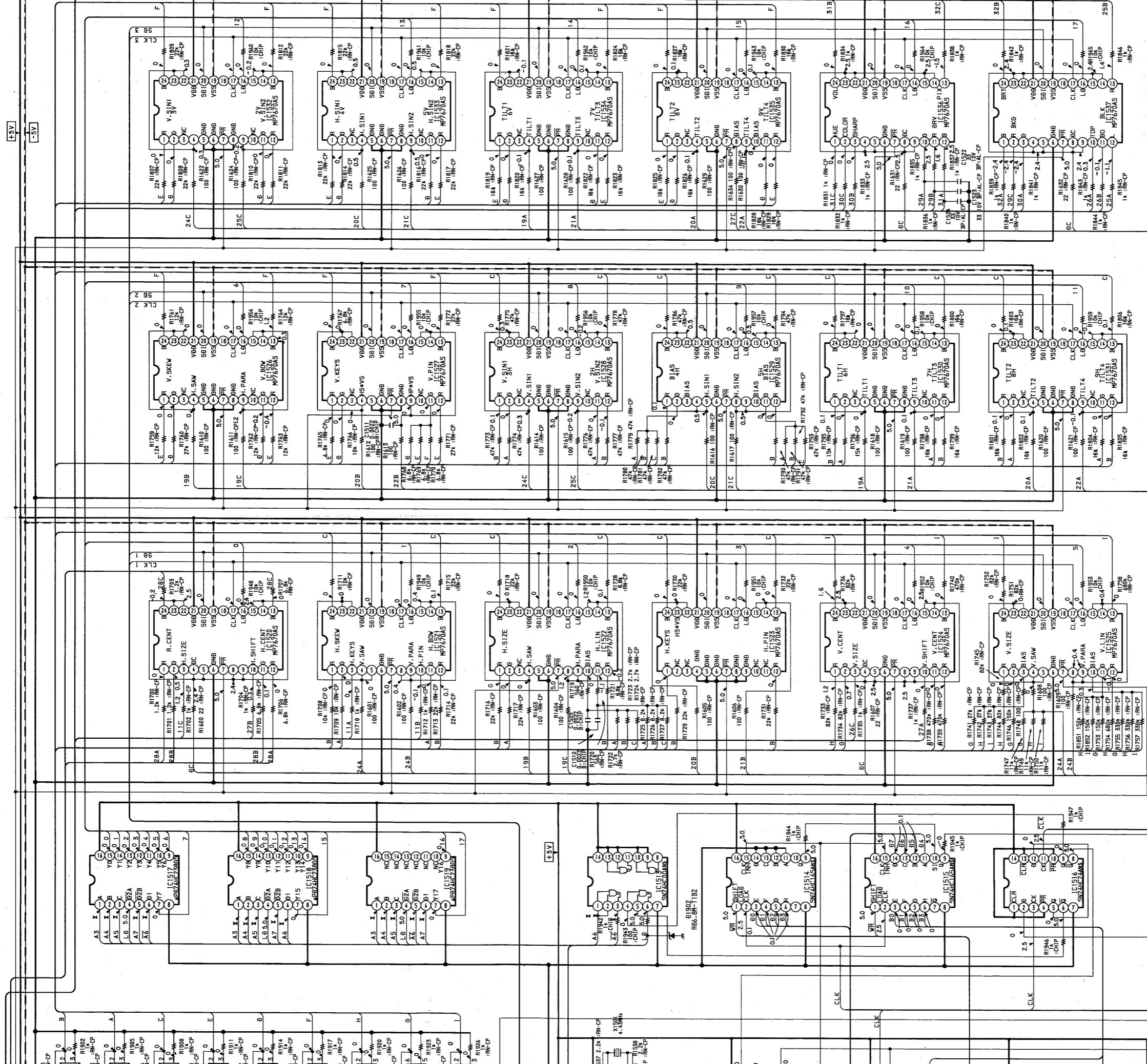

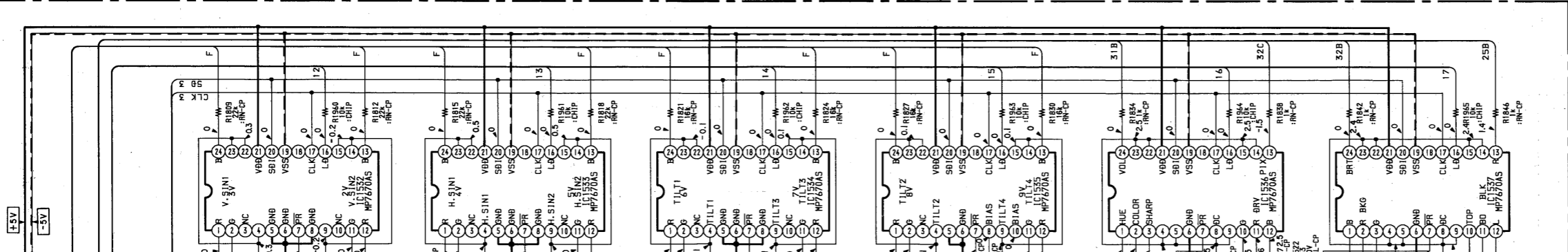

DB BOARD

IC1501	+5V REG.
IC1502	-5V REG.
IC1503	VOLTAGE REF.
IC1504	ADDRESS LATCHES
IC1505	DATA BUFF.
IC1506	DATA BUS BUFF.
IC1507	ADDRESS BUS BUFF.
IC1508	OSC
IC1509	DFF-1
IC1510	ADDER 1
IC1511	ADDER 2
IC1512	COUNTER
IC1513	NAND GATES
IC1514	PARA-SERI CONV. 1
IC1515	PARA-SERI CONV. 2
IC1516	DFF-2
IC1517	ADDRESS DEC 1
IC1518	ADDRESS DEC 2
IC1519	ADDRESS DEC 3
IC1520	H. CENT ADJ.
IC1521	H. SKEW/BOW ADJ.
IC1522	H. SIZE/LIN ADJ.
IC1523	H. KEYS/PIN ADJ.
IC1524	V. CENT ADJ.
IC1525	V. SIZE/LIN ADJ.
IC1526	V. SKEW/BOW ADJ.
IC1527	V. KEYS/PIN ADJ.
IC1528	H. ZONE 2/3 ADJ.
IC1529	H. ZONE 4/5 ADJ.
IC1530	H. ZONE 6/7 ADJ.
IC1531	H. ZONE 8/9 ADJ.
IC1532	V. ZONE 2/3 ADJ.
IC1533	V. ZONE 4/5 ADJ.
IC1534	V. ZONE 6/7 ADJ.
IC1535	V. ZONE 8/9 ADJ.
IC1536	USER CONT. 1
IC1537	USER CONT. 2
IC1538	R H. SUB BUFF-AMP
IC1539	G H. SUB BUFF-AMP
IC1540	B H. SUB BUFF-AMP
IC1541	R V. SUB BUFF-AMP
IC1542	G V. SUB BUFF-AMP
IC1543	B V. SUB BUFF-AMP
IC1544	V. MAIN BUFF-AMP 1
IC1545	V. MAIN BUFF-AMP 2
IC1546	+12V REG.
IC1547	-12V REG.
IC1548	P-ON RESET
D1501	+5V REG. PROT.
D1502	-5V REG. PROT.
D1503	B V. OUT PROT. 1
D1504	G V. OUT PROT. 1
D1505	R V. OUT PROT. 1
D1506	B V. OUT PROT. 2
D1507	G V. OUT PROT. 2
D1508	R V. OUT PROT. 2
D1509	DISCHARGE
D1510	+12V REG. PROT.
D1511	-12V REG. PROT.
D1901	WR PROT.
D1902	LD PROT.

DB BOARD

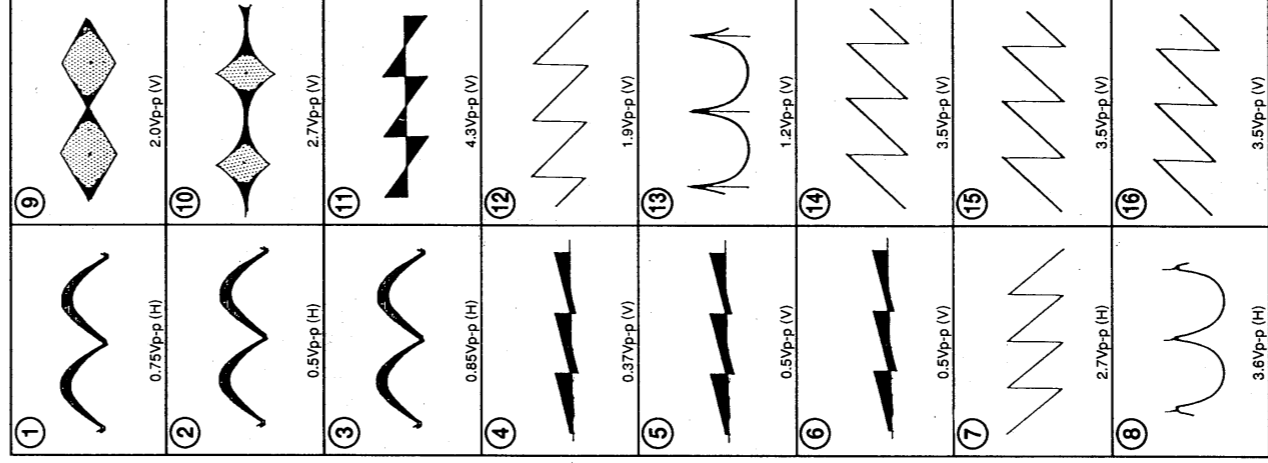

DB [ELECTRIC VOLUME]

- DB BOARD - <Component Side>

DB BOARD
(COMPONENT SIDE)

IC	
IC1501	E-8
IC1502	E-3
IC1503	E-2
IC1520	A-3
IC1521	A-7
IC1522	A-6
IC1523	A-5
IC1524	A-3
IC1525	A-4
IC1526	B-7
IC1527	B-6
IC1528	B-5
IC1529	B-4
IC1530	B-3
IC1531	B-3
IC1532	C-7
IC1533	C-6
IC1534	C-5
IC1535	C-4
IC1536	C-4
IC1537	C-3
IC1538	B-1
IC1539	B-2
IC1540	C-2
IC1541	C-1
IC1542	D-2
IC1543	D-1
IC1544	A-2
IC1545	B-2
IC1546	E-1
IC1547	D-2
IC1548	D-2

DIODE	
D1501	E-9
D1502	E-2
D1503	E-8
D1504	E-8
D1505	E-8
D1506	E-8
D1507	E-9
D1508	E-8
D1509	E-2
D1510	E-1
D1511	D-1

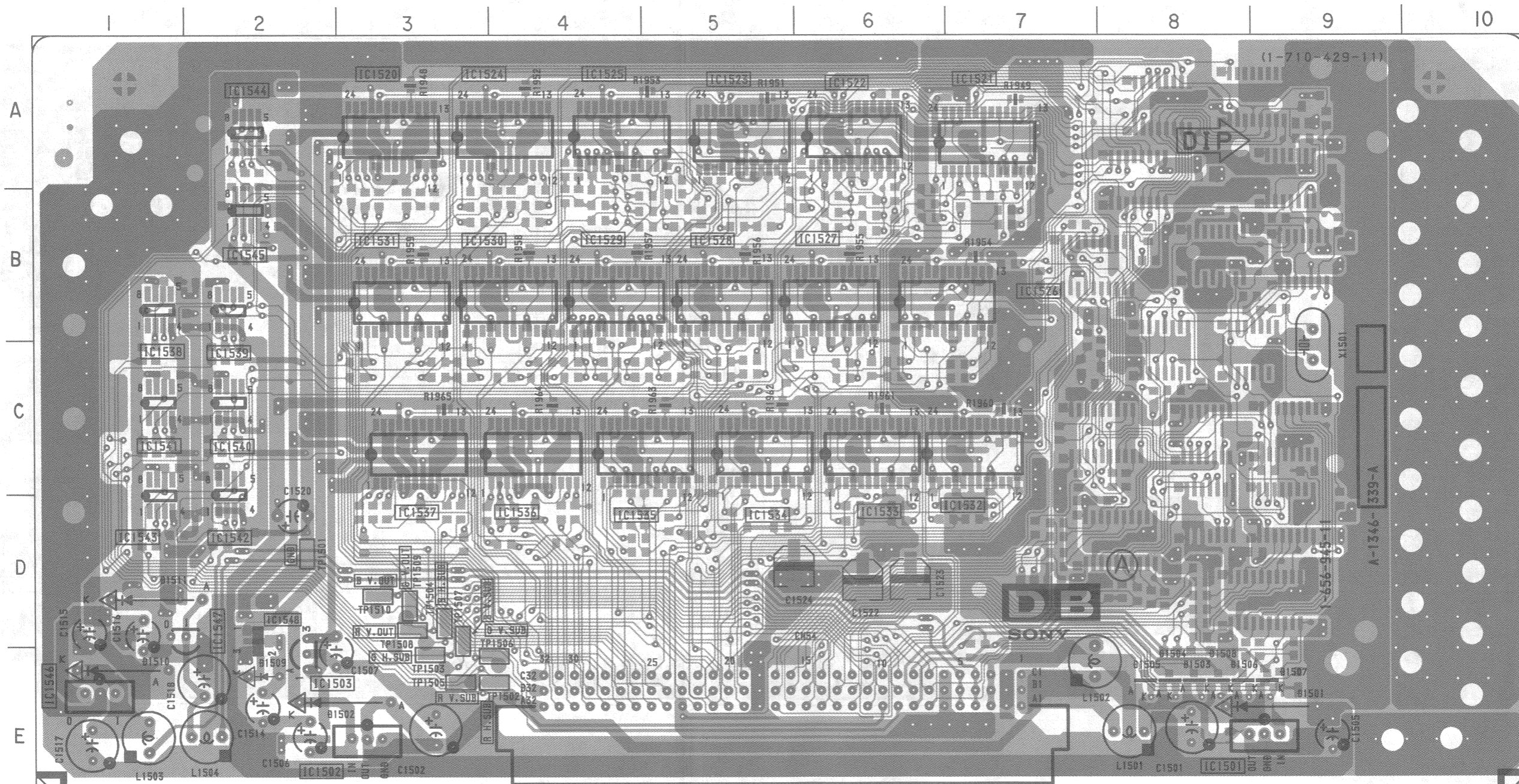

<Conductor Side>

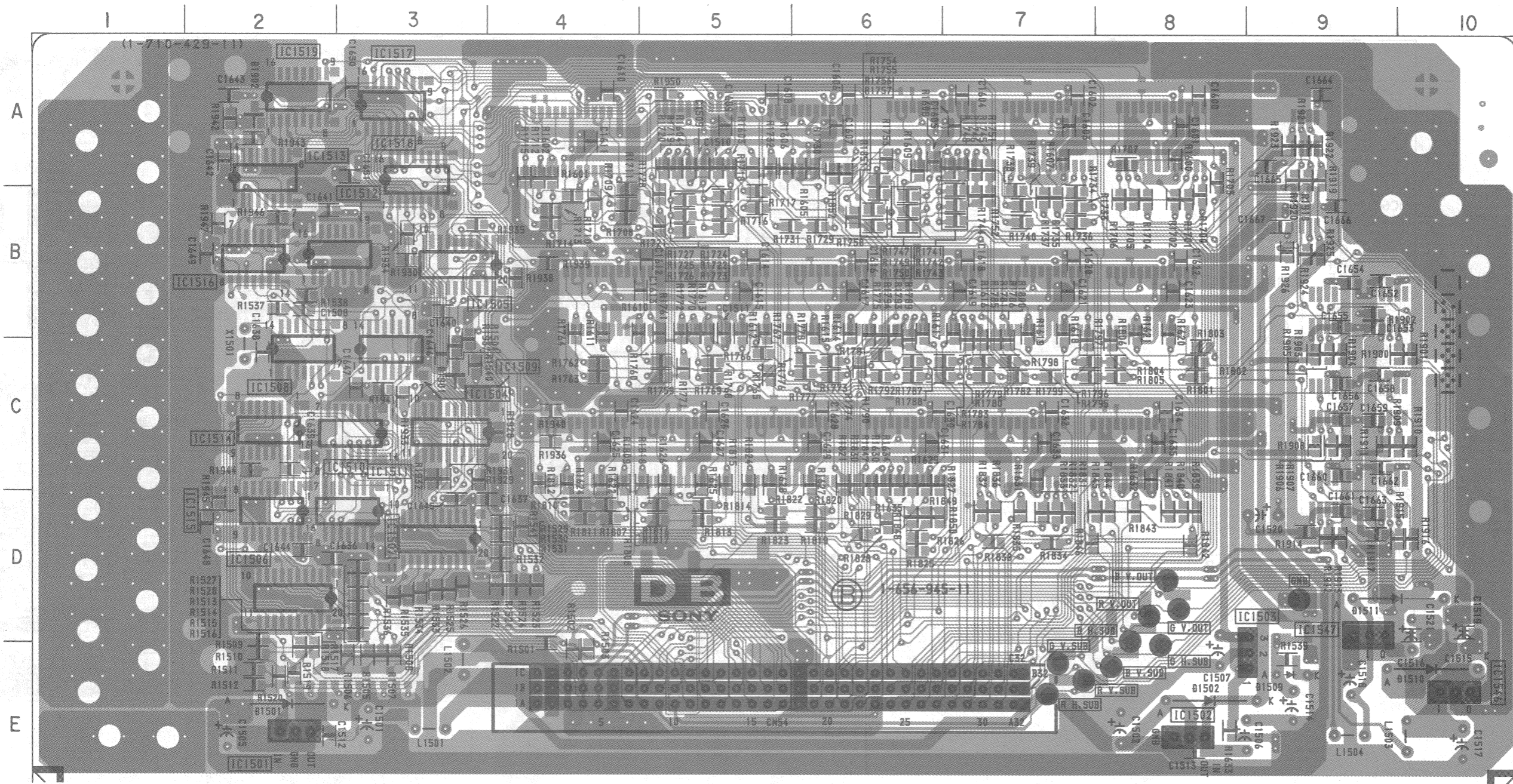

DB BOARD
(CONDUCTOR SIDE)

IC	
IC1501	E-2
IC1502	E-8
IC1503	E-9
IC1504	C-3
IC1505	B-3
IC1506	D-2
IC1507	D-3
IC1508	C-2
IC1509	C-3
IC1510	C-3
IC1511	D-3
IC1512	B-3
IC1513	A-2
IC1514	C-2
IC1515	D-2
IC1516	B-2
IC1517	A-3
IC1518	A-3
IC1519	A-2
IC1546	E-10
IC1547	D-9

DIODE	
D1501	E-2
D1502	E-8
D1509	E-9
D1510	E-10
D1511	D-9
D1901	C-3
D1902	A-2

: Pattern from the side which enables seeing.
 : Pattern of the rear side.

DE

[ELECTRIC VOLUME, WAVEFORM GEN.]

- DE BOARD - <Component Side>

DE BOARD
(COMPONENT SIDE)

IC		
IC501	B-9	IC540 C-4
IC502	B-10	IC541 C-4
IC503	C-9	IC542 C-5
IC504	E-8	IC543 C-6
IC505	D-8	IC544 B-6
IC506	D-8	IC545 E-6
IC507	B-6	IC601 B-7
IC508	A-5	IC602 B-7
IC509	D-9	IC603 C-7
IC510	C-9	IC604 B-8
IC511	C-10	IC605 B-8
IC512	C-9	IC606 C-8
IC513	A-4	IC607 B-8
IC514	B-5	IC608 B-8
IC515	A-3	IC609 C-8
IC516	B-3	
IC517	B-2	TRANSISTOR
IC518	A-2	Q501 C-9
IC519	B-1	Q502 C-10
IC520	A-1	Q503 D-10
IC521	B-1	Q504 B-2
IC522	B-2	Q505 B-2
IC523	D-1	
IC524	D-2	DIODE
IC525	D-3	D352 C-9
IC526	D-3	D501 B-10
IC527	D-4	D502 B-10
IC528	D-5	D503 B-9
IC529	D-6	D505 A-2
IC530	E-1	D506 A-2
IC531	E-2	D507 B-2
IC532	E-3	D508 A-2
IC533	E-3	
IC534	E-4	VARIABLE RESISTOR
IC535	E-5	RV701 E-9
IC536	E-6	RV702 E-9
IC537	C-1	RV703 E-9
IC538	C-2	
IC539	C-3	

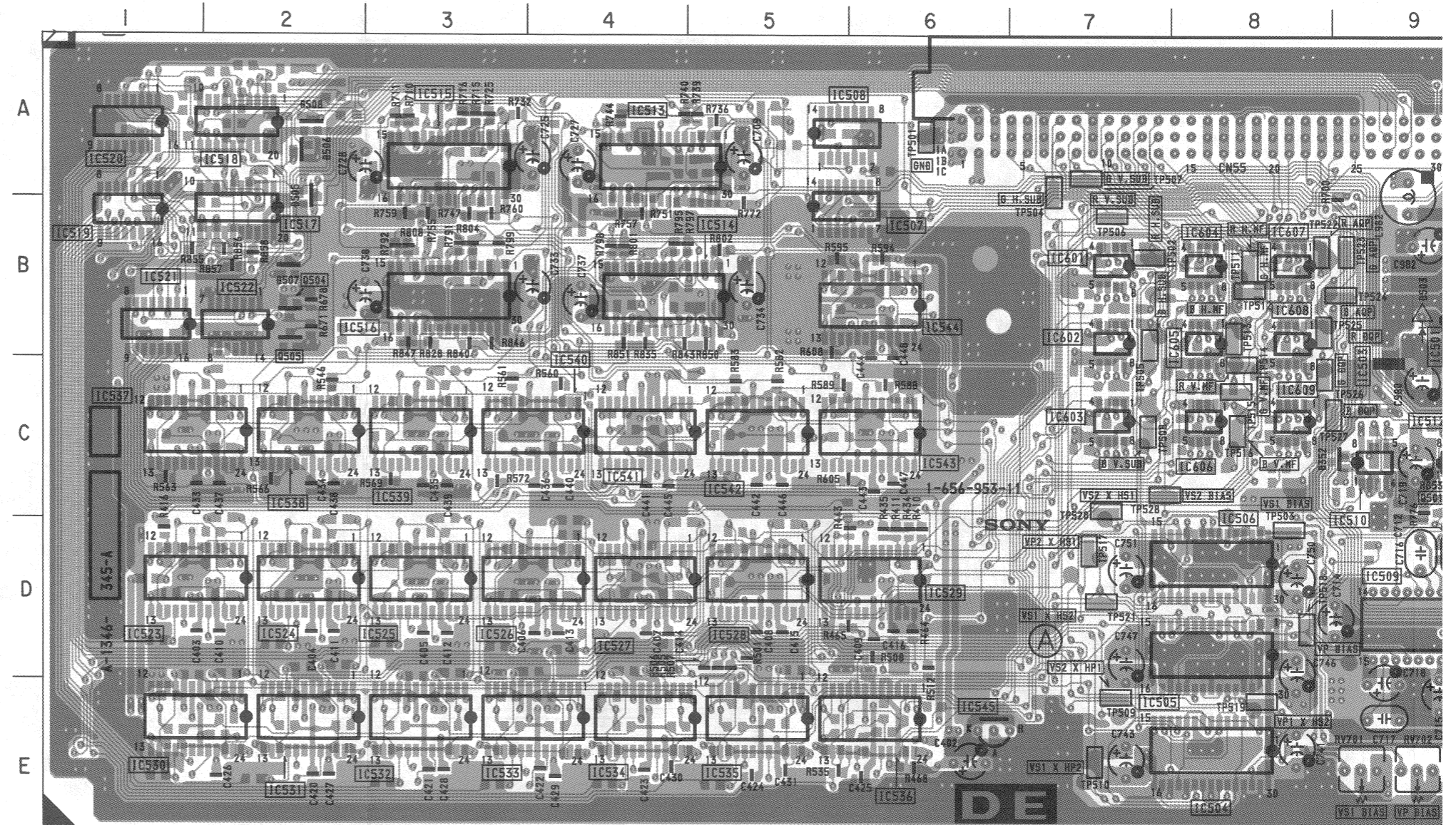

<Conductor Side>

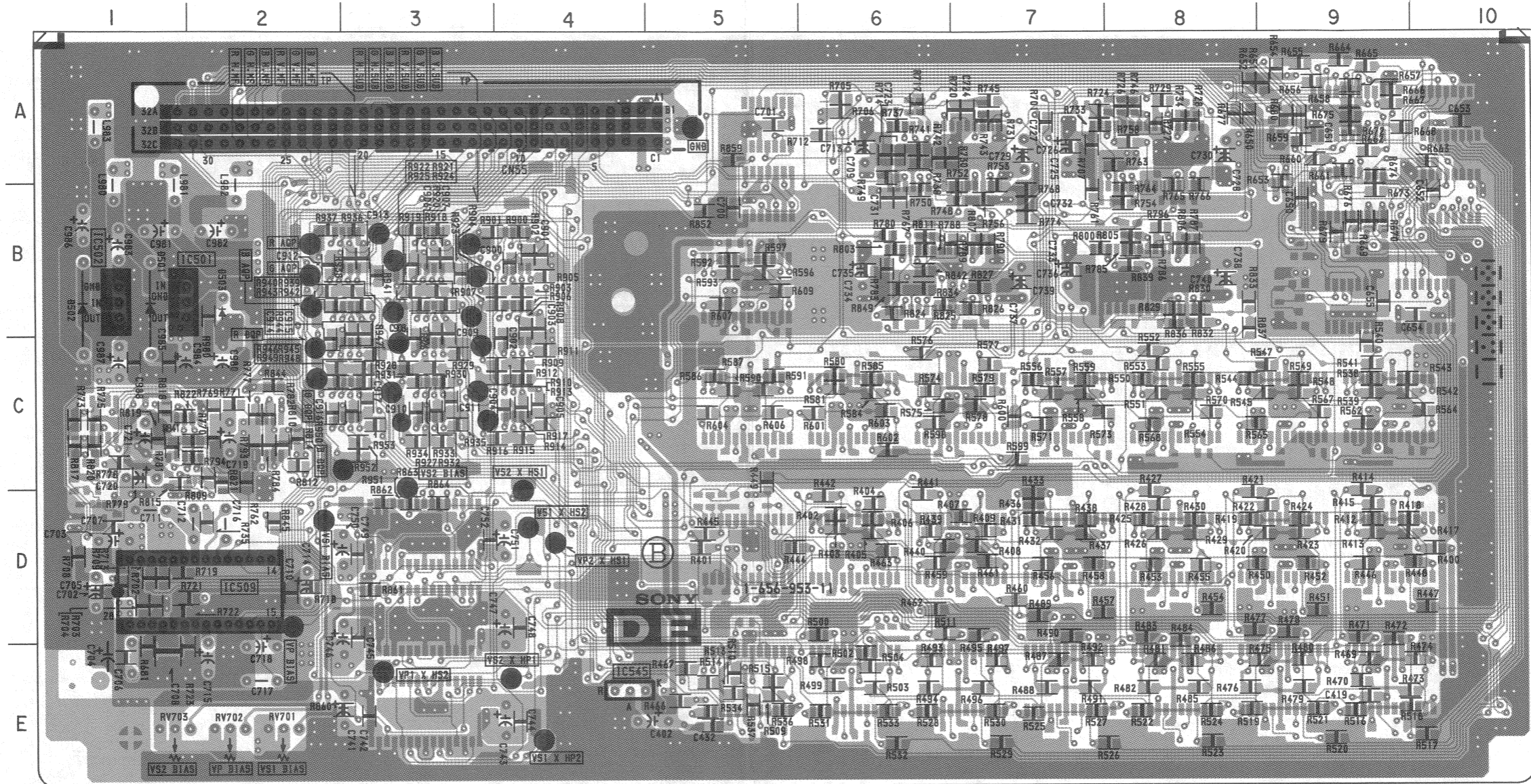
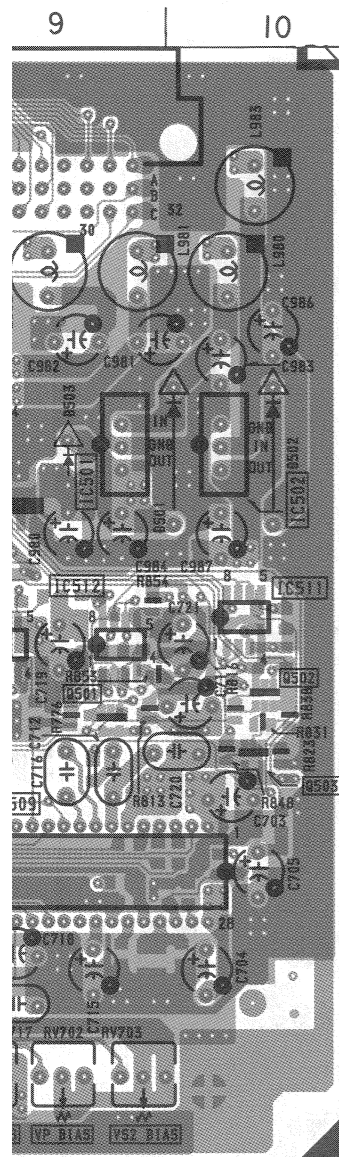

DE BOARD
(CONDUCTOR SIDE)

IC	
IC501	B-1
IC502	B-1
IC509	D-2
IC545	E-4
DIODE	
D501	B-1
D502	B-1
D503	B-2
VARIABLE RESISTOR	
RV701	E-2
RV702	E-2
RV703	E-1

- : Pattern from the side which enables seeing.
- : Pattern of the rear side.

SCHEMATIC DIAGRAMS AND PRINTED WIRING BOARDS

DE (1/2) BOARD

The following diagram has been divided into 3 sections as noted on the grid shown below.

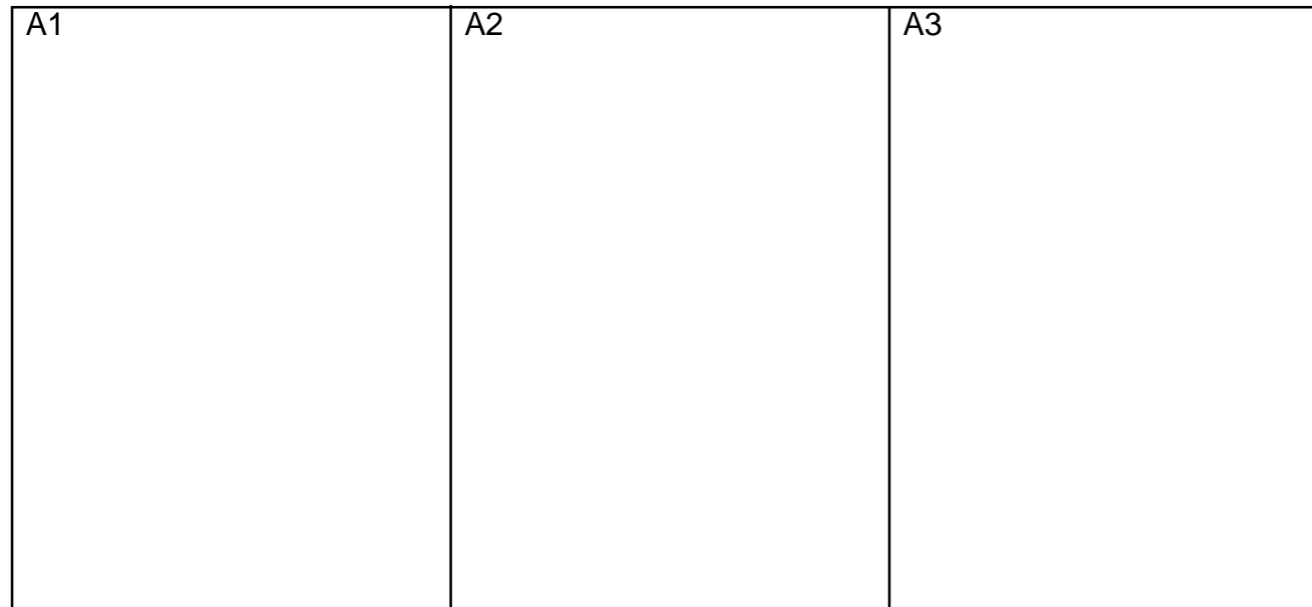

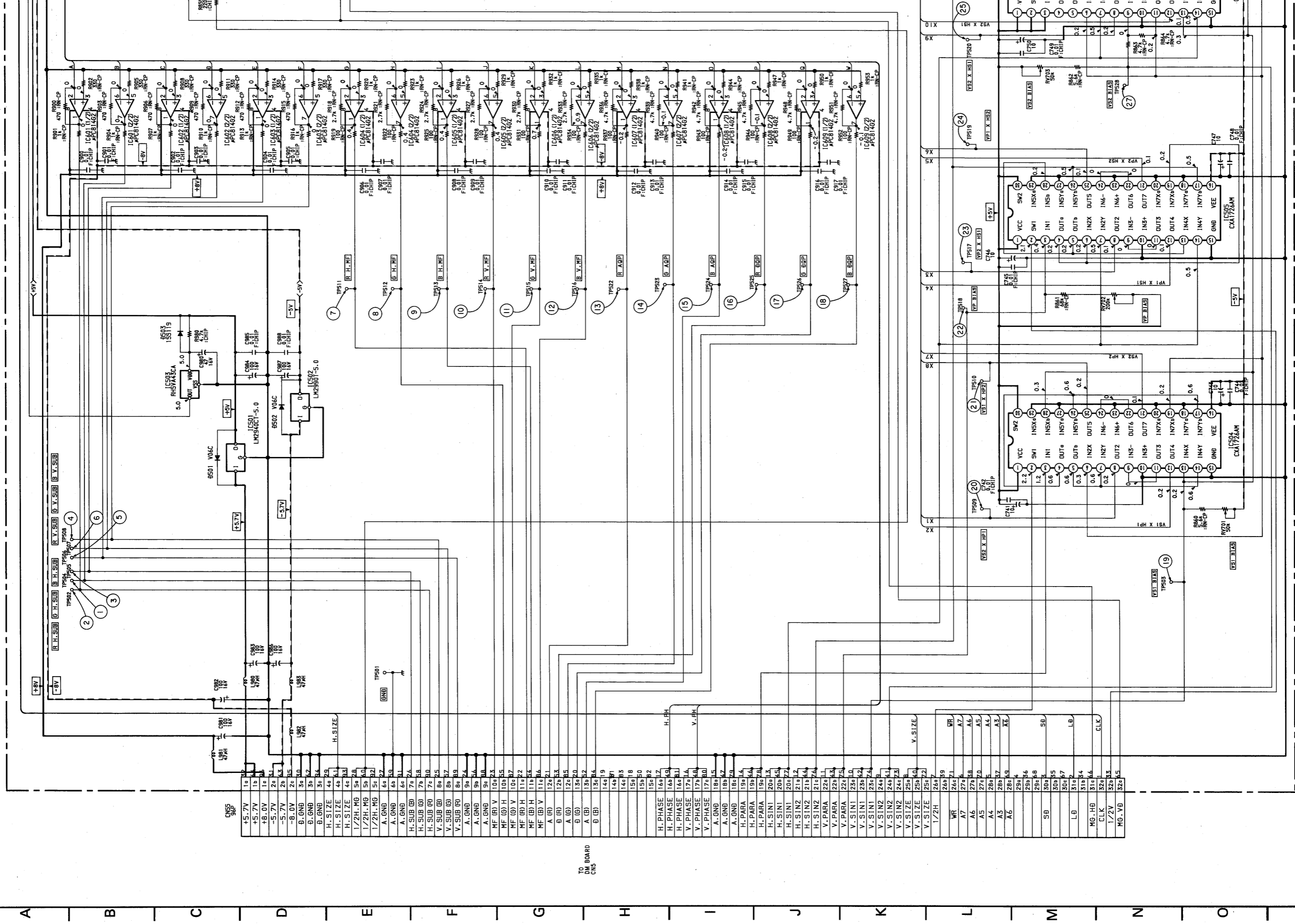

TO DM BOARD
CNS

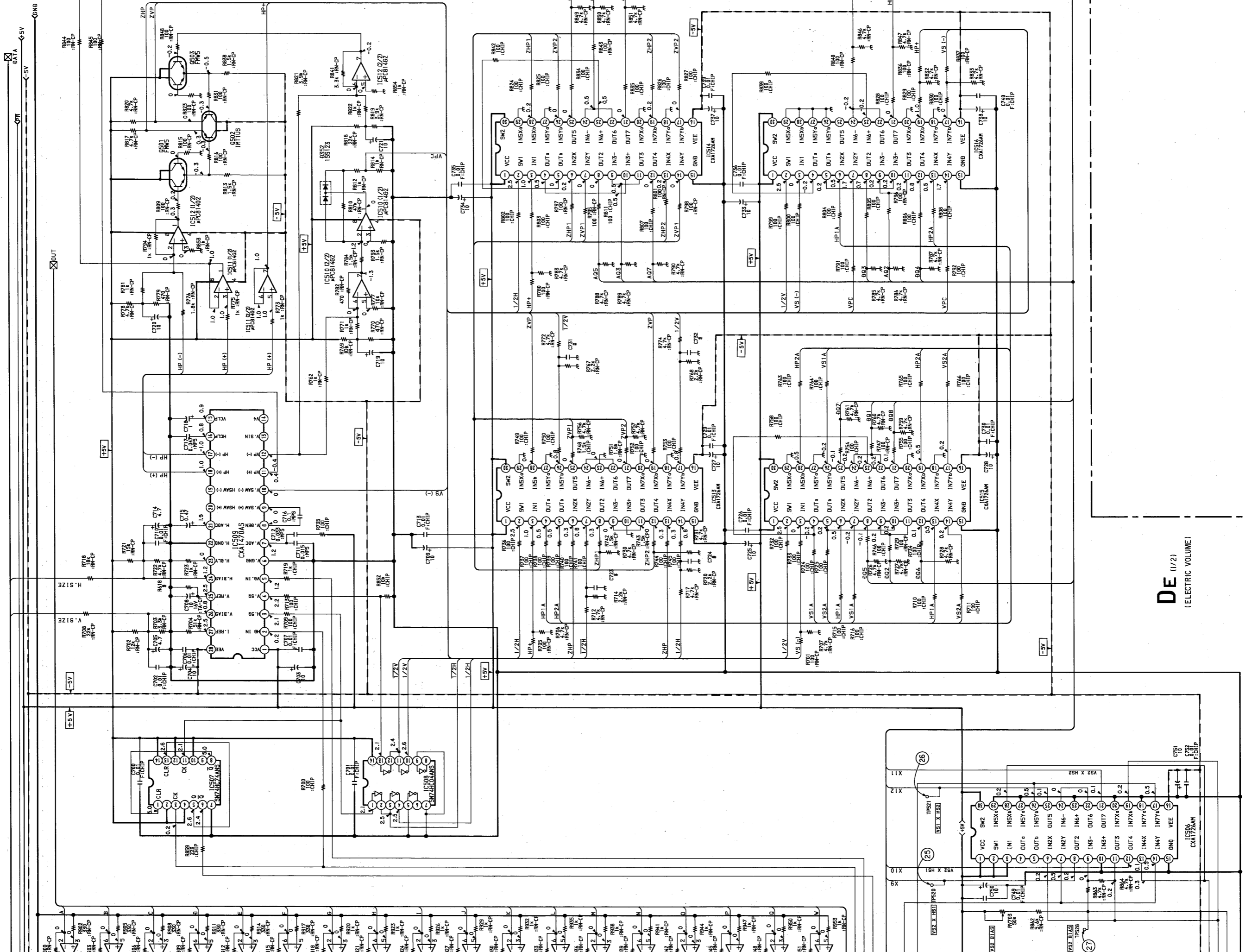

DE (1/2)
(ELECTRIC VOLUME)

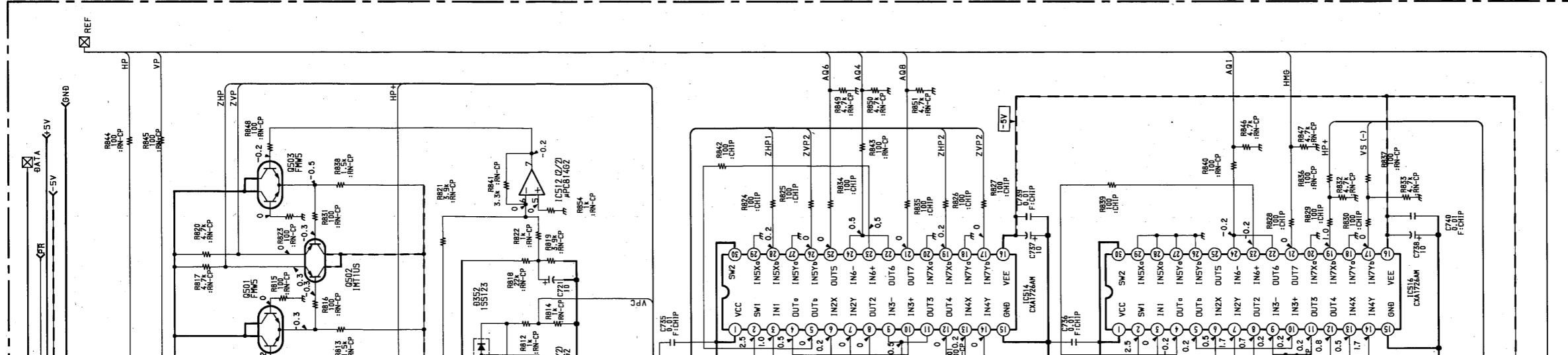

DE (1/2) BOARD

IC501	+5V REG.
IC502	-5V REG.
IC503	P-ON RESET
IC504	REGI MULTIPLEX 1
IC505	REGI MULTIPLEX 2
IC506	REGI MULTIPLEX 3
IC507	1/2 H. MG GEN.
IC508	INVERTER
IC509	MG WAVE FORM GEN.
IC510	VPC DET.
IC511	HP BUFF.
IC512	DC SHIFT
IC513	OP MULTIPLEX 1
IC514	OP MULTIPLEX 2
IC515	OP MULTIPLEX 3
IC516	OP MULTIPLEX 4
IC601	SUB BUFF. AMP 1
IC602	SUB BUFF. AMP 2
IC603	SUB BUFF. AMP 3
IC604	MF BUFF. AMP 1
IC605	MF BUFF. AMP 2
IC606	MF BUFF. AMP 3
IC607	QP BUFF. AMP 1
IC608	QP BUFF. AMP 2
IC609	QP BUFF. AMP 3
Q501	ZHP SW
Q502	ZHP/ZVP BUFF.
Q503	ZVP SW
D352	VPC SLICE
D501	+5V REG. PROT.
D502	-5V REG. PROT.
D503	DISCHARGE

DE (1/2) BOARD

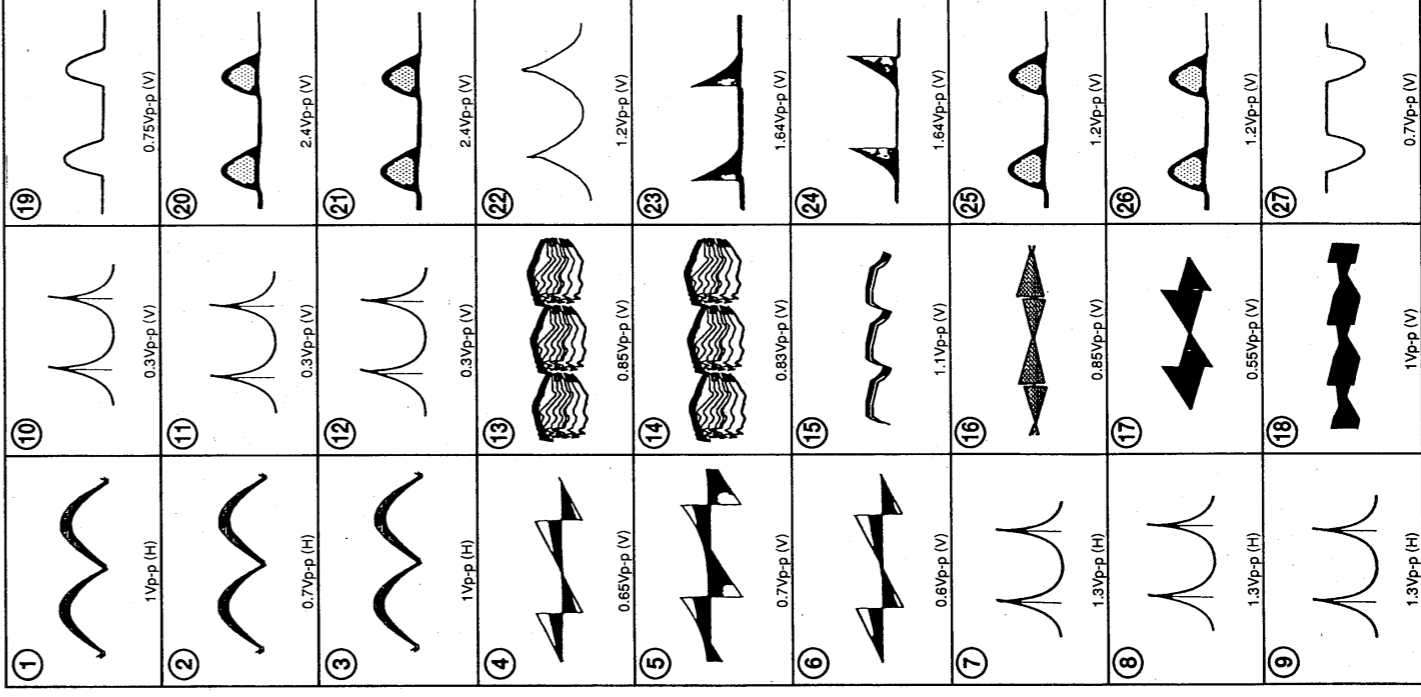

SCHEMATIC DIAGRAMS AND PRINTED WIRING BOARDS

DE (2/2) BOARD

The following diagram has been divided into 3 sections as noted on the grid shown below.

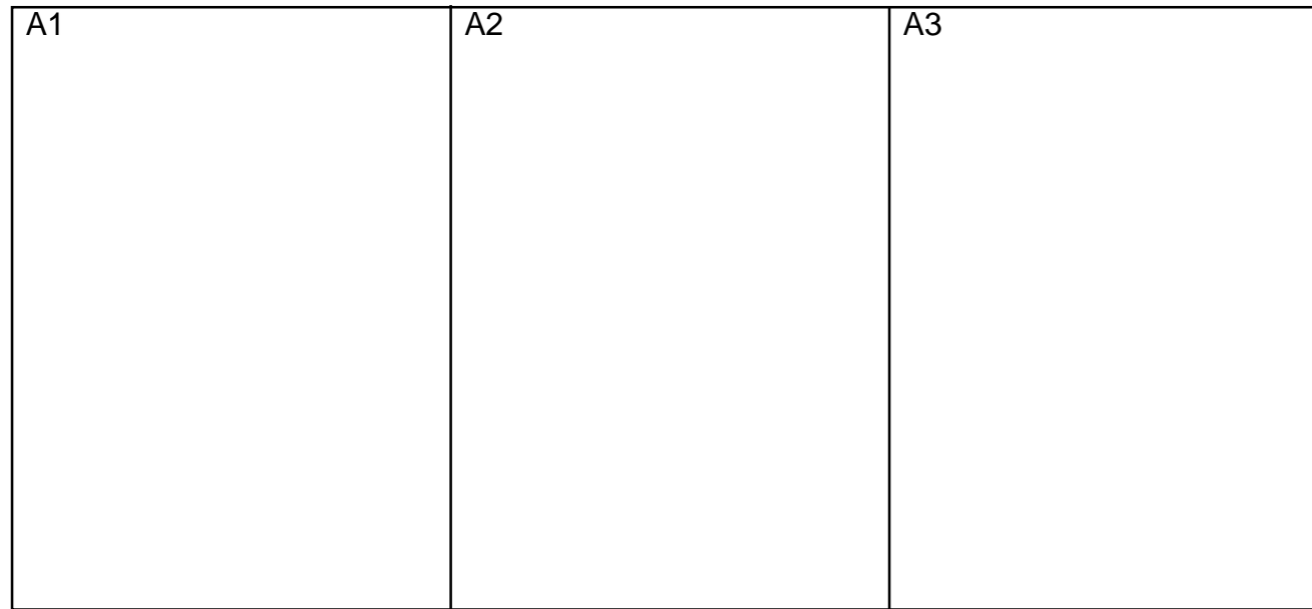

A1 1 2 3 4 5 6 7 8 9 10 11

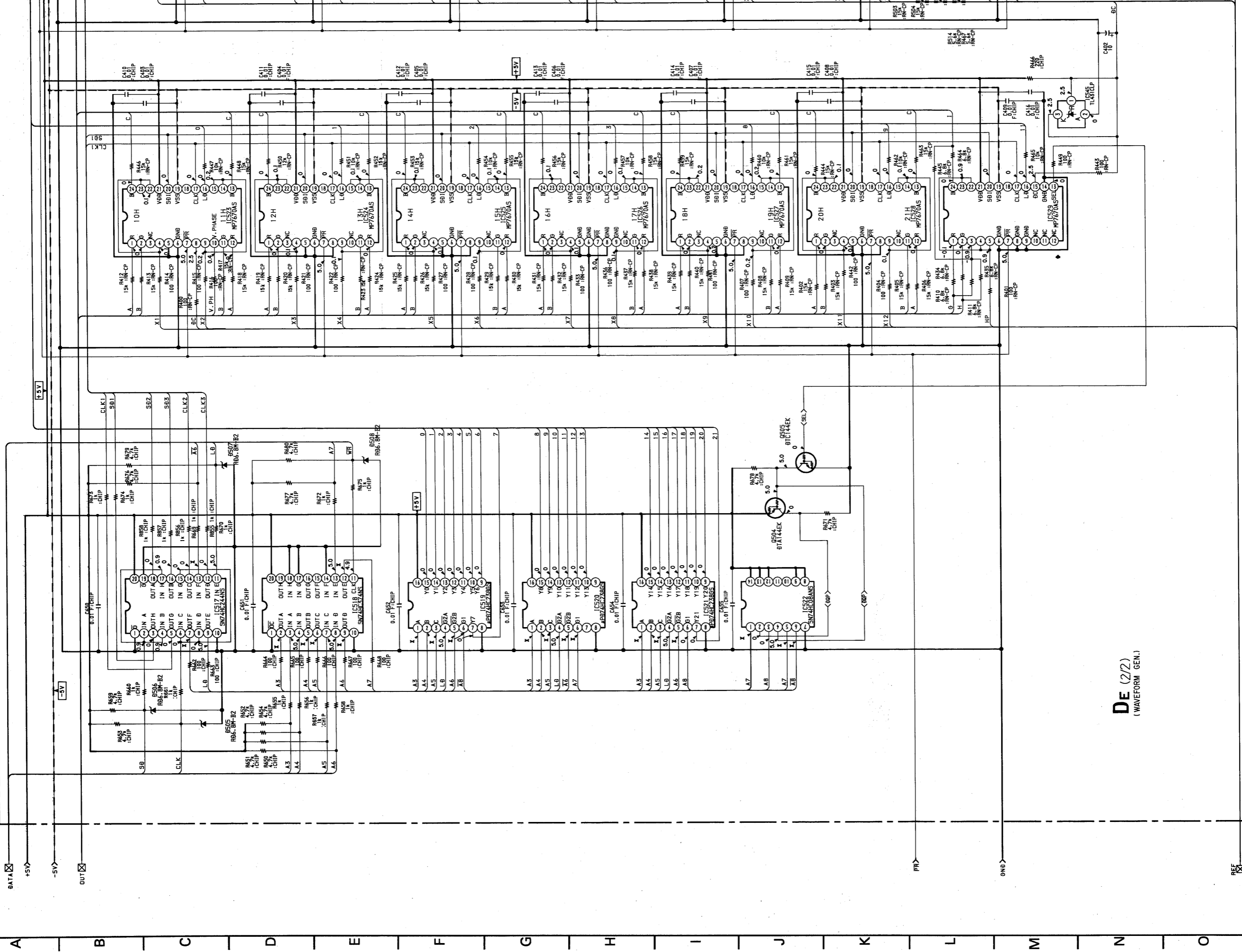

DE (2/2)
(WAVEFORM GEN.)

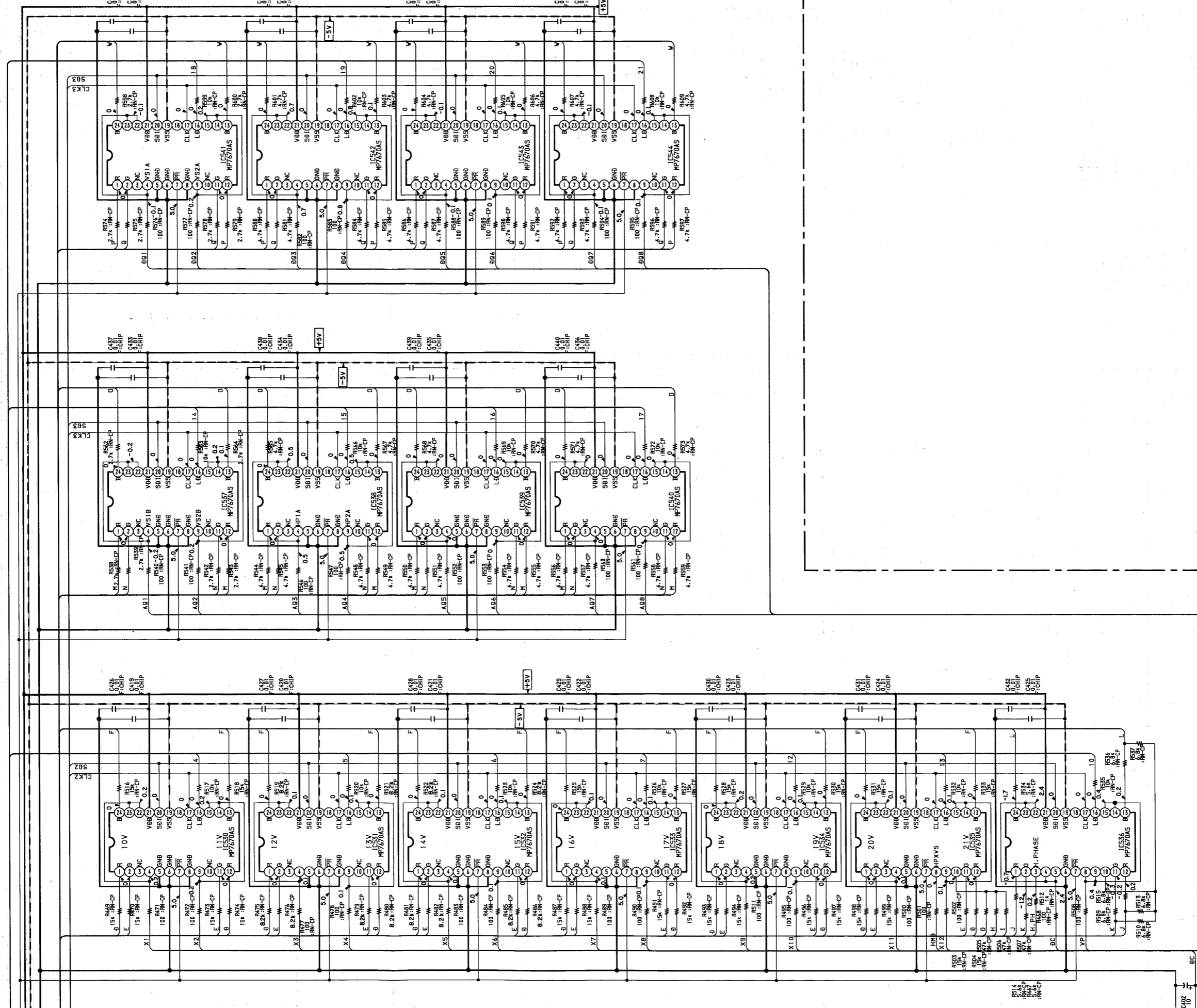

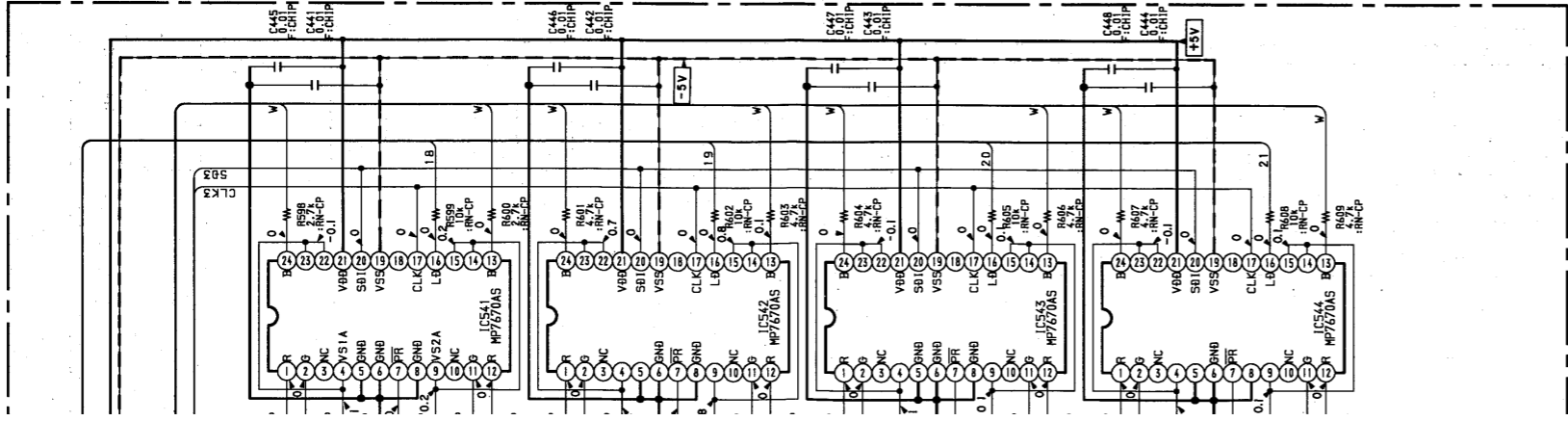

DE (2/2) BOARD

IC517	DATA BUFF.
IC518	ADDRESS LATCHES
IC519	ADDRESS DEC. 1
IC520	ADDRESS DEC. 2
IC521	ADDRESS DEC. 3
IC522	AND GATES
IC523	H. ZONE 10/11 ADJ.
IC524	H. ZONE 12/13 ADJ.
IC525	H. ZONE 14/15 ADJ.
IC526	H. ZONE 16/17 ADJ.
IC527	H. ZONE 18/19 ADJ.
IC528	H. ZONE 20/21 ADJ.
IC529	MG H. ADJ.
IC530	V. ZONE 10/11 ADJ.
IC531	V. ZONE 12/13 ADJ.
IC532	V. ZONE 14/15 ADJ.
IC533	V. ZONE 16/17 ADJ.
IC534	V. ZONE 18/19 ADJ.
IC535	V. ZONE 20/21 ADJ.
IC536	MC ALLV ADJ.
IC537	AQP 1/2 ADJ.
IC538	AQP 3/4 ADJ.
IC539	AQP 5/6 ADJ.
IC540	AQP 7/8 ADJ.
IC541	DQP 1/2 ADJ.
IC542	DQP 3/4 ADJ.
IC543	DQP 5/6 ADJ.
IC544	DQP 7/8 ADJ.
IC545	VOLTAGE REF.
Q504	DAC SEL
Q505	DAC SEL 2
D505	CLK PROT.
D506	SD PROT.
D507	LD PROT.
D508	WR PROT.

DCA

[AMP]

DCC

- DCA BOARD -

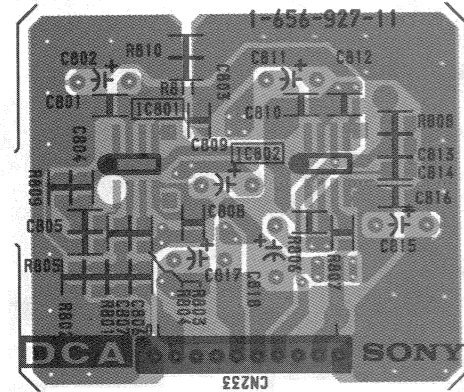

- DCC BOARD -

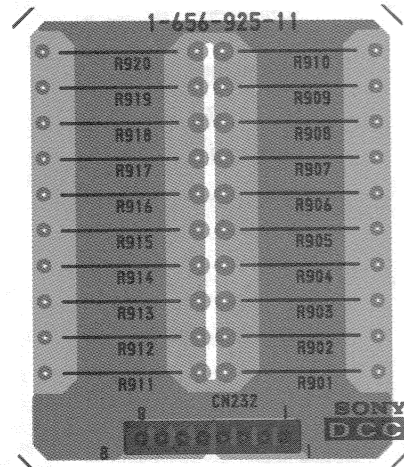

- : Pattern from the side which enables seeing.
- : Pattern of the rear side.

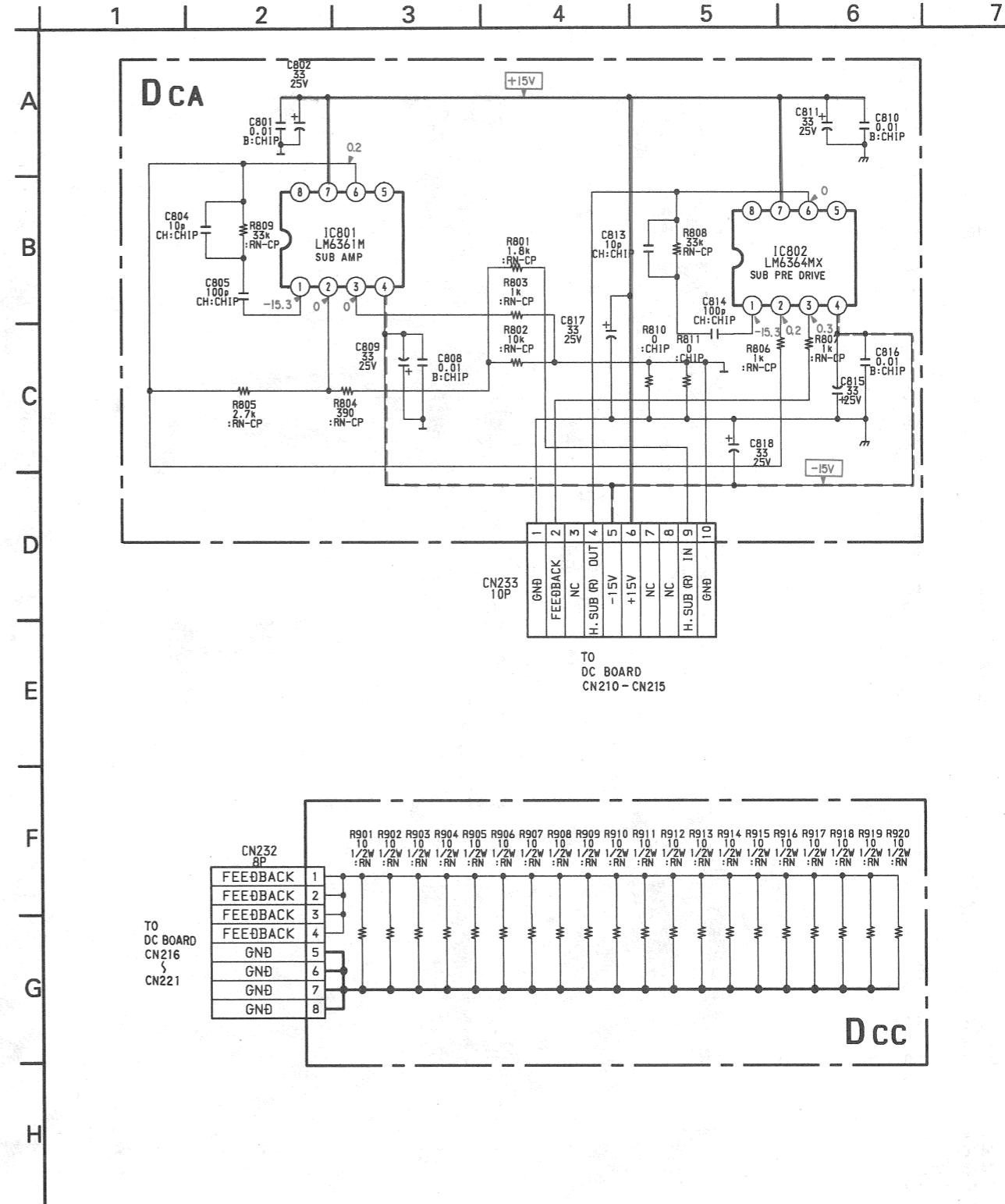

DC [SUB DY DRIVER]

DC BOARD

IC		D12	C-2
IC11 F-3		D13	E-2
IC50 G-3		D14	F-3
IC70 I-4		D15	F-3
		D16	F-2
TRANSISTOR		D41	I-3
Q1 H-4		D50	G-2
Q2 F-3		D51	G-3
Q3 G-5		D60	G-2
Q4 H-4		D61	G-4
Q5 J-4		D71	I-4
Q6 H-2		D81	I-4
Q7 G-3		D82	I-4
Q9 C-2		D101	H-6
Q10 D-2		D102	H-6
Q11 E-2		D103	H-9
Q12 D-2		D104	H-9
Q13 D-2		D105	H-11
Q101 A-6		D106	H-11
Q102 A-3		D111	I-6
Q103 A-8		D112	I-6
Q104 A-6		D113	I-9
Q105 A-11		D114	I-8
Q106 A-9		D115	I-11
Q301 F-13		D116	I-10
Q302 J-6		D201	A-6
Q303 J-5		D202	B-4
Q304 H-7		D203	A-9
Q305 H-6		D204	B-7
Q306 H-7		D205	A-12
Q307 H-6		D206	B-9
Q308 J-9		D211	B-5
Q309 J-7		D212	B-6
Q310 H-9		D213	A-3
Q311 H-9		D214	B-4
Q312 H-9		D215	B-8
Q313 H-9		D216	B-9
Q314 J-11		D217	A-6
Q315 J-10		D218	B-7
Q316 H-11		D219	B-11
Q317 H-11		D220	B-11
Q318 H-11		D221	A-9
Q319 H-11		D222	B-10
Q401 C-13		D231	B-5
Q403 C-1		D232	B-5
Q405 A-5		D233	B-8
Q406 A-4		D234	B-7
Q407 B-6		D235	B-11
Q408 B-6		D236	B-10
Q409 C-6		D302	H-7
Q410 C-6		D303	H-6
Q411 A-8		D306	H-7
Q412 A-7		D307	G-7
Q413 B-9		D308	H-9
Q414 B-8		D309	H-9
Q415 C9		D312	H-10
Q416 C8		D313	G-9
Q417 A11		D314	H-12
Q418 A-10		D315	H-11
Q419 B-11		D318	H-12
Q420 B-11		D319	G-11
Q421 C-11		D403	C-6
Q422 C-11		D404	C-6
		D407	C-7
		D408	D-6
		D409	C-8
		D410	C-8
DIODE		D413	C-9
D5 G-4		D414	D-9
D8 D-2		D415	C-11
D9 D-2		D416	C-11
D10 C-2		D419	C-11
D11 F-2		D420	D-11

■ : Pattern from the side which enables seeing.
 ■ : Pattern of the rear side.

- DC BOARD -

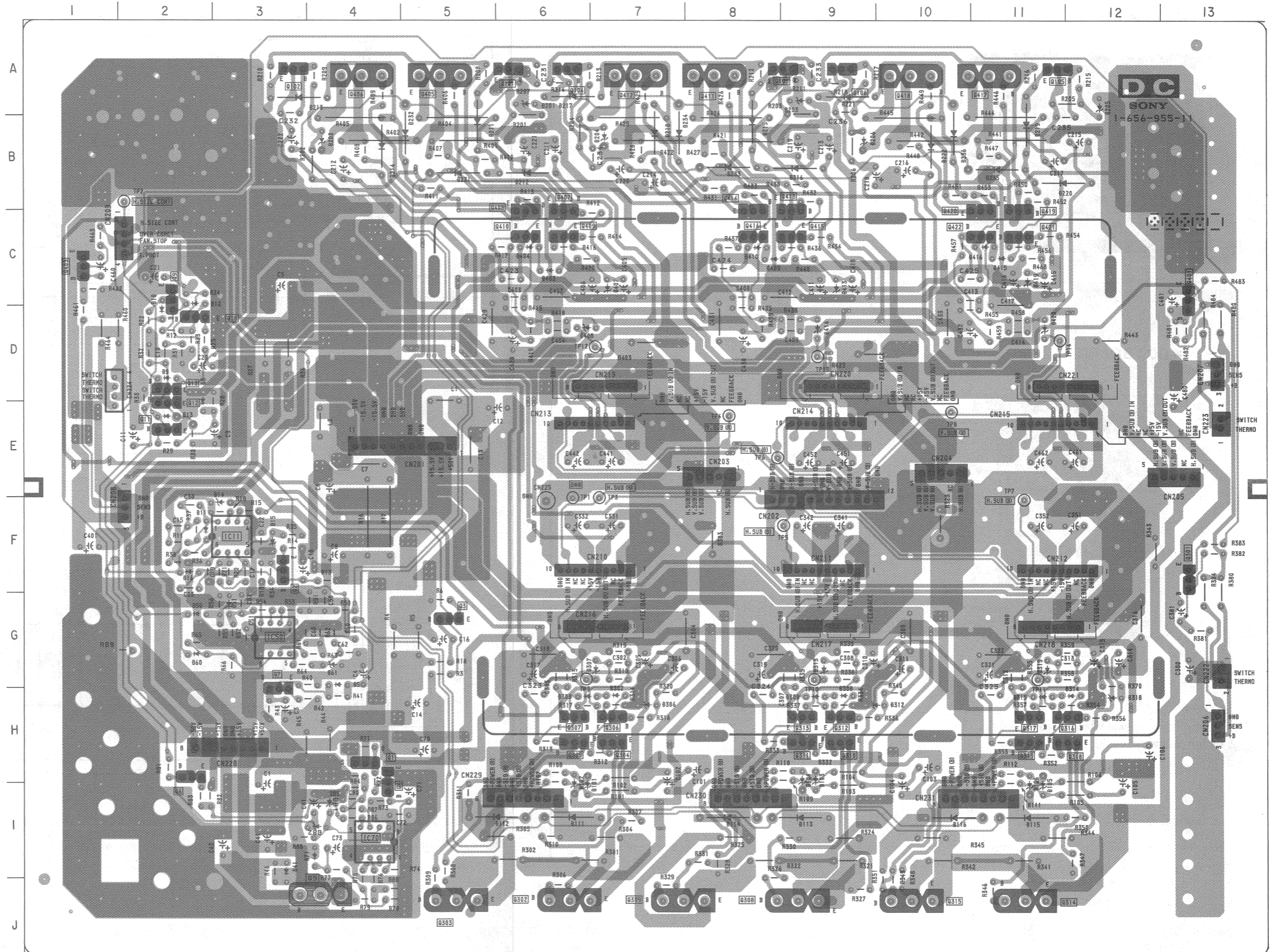

SCHEMATIC DIAGRAMS AND PRINTED WIRING BOARDS

DC BOARD

The following diagram has been divided into 3 sections as noted on the grid shown below.

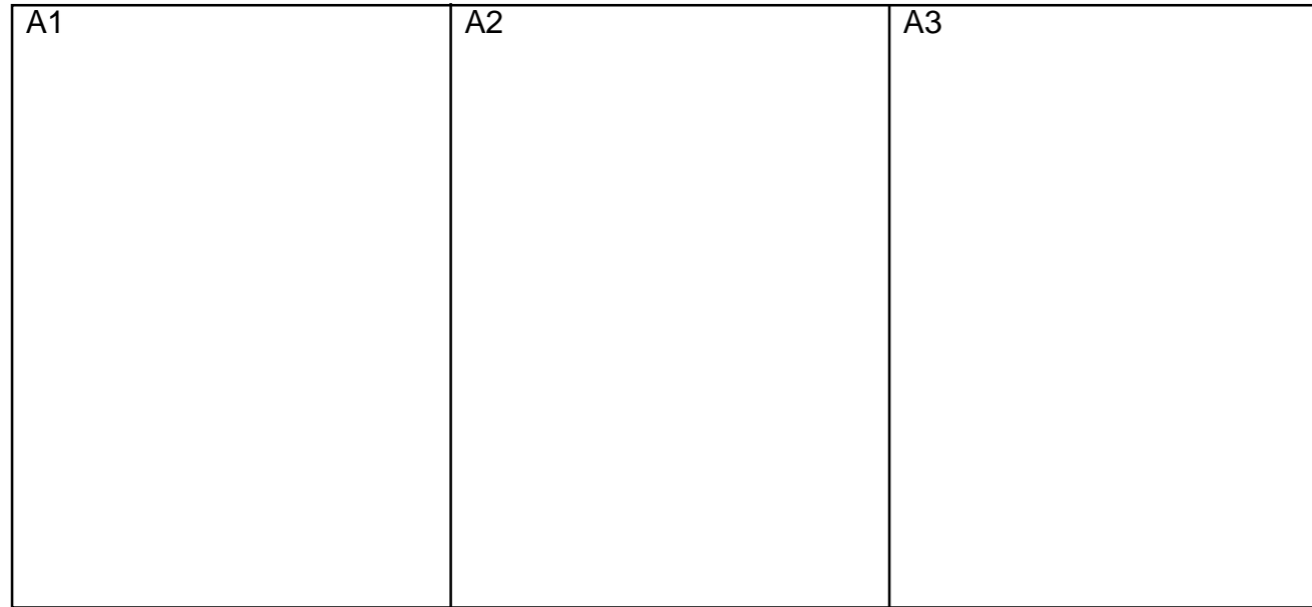

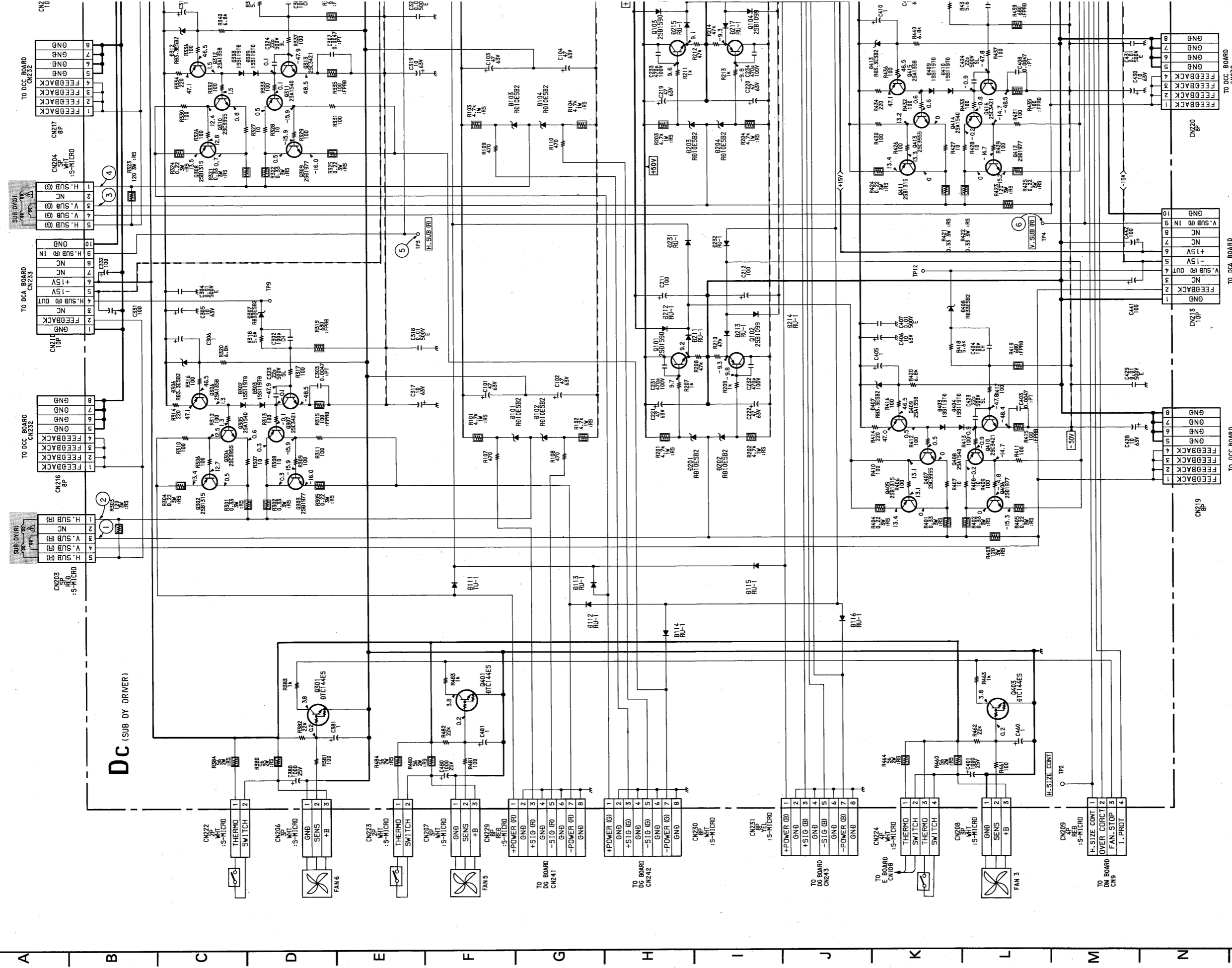

DC (SUB DY DRIVER)

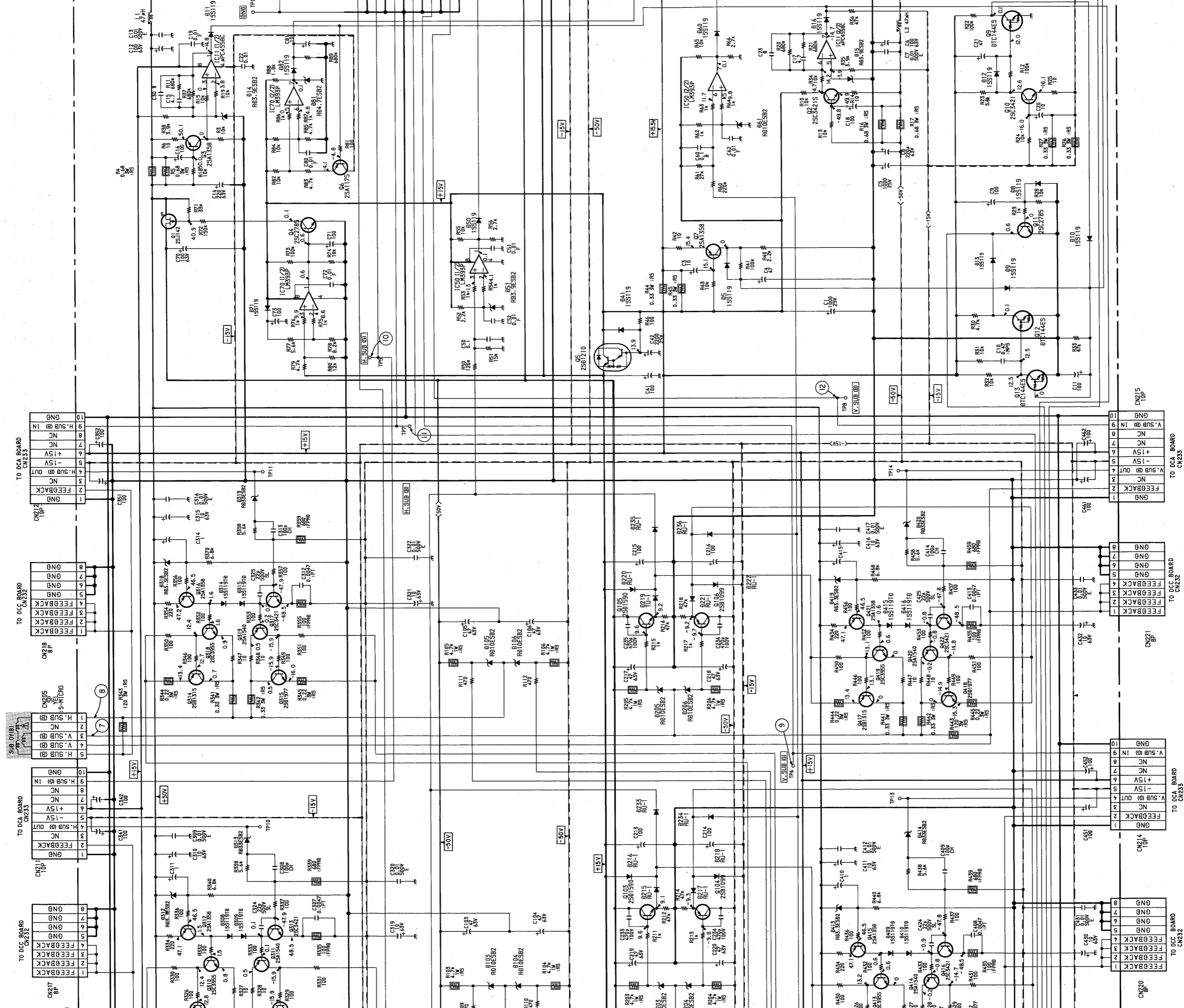

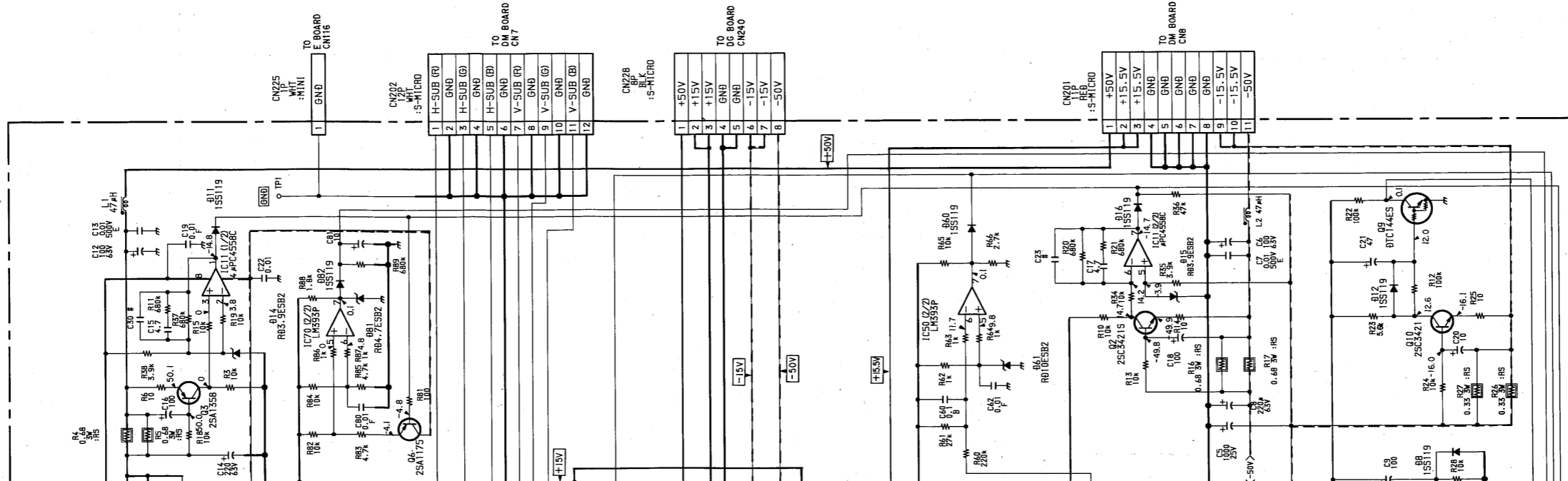

DC BOARD

IC11	H. SIZE	D14	BIAS
IC50	COMPARATER	D15	BIAS
IC70	COMPARATER	D16	GATE
		D41	DISCHARGE
		D50	GATE
Q1	+50V SW2	D51	BIAS
Q2	-50V CURRENT PROT.	D60	GATE
Q3	+50V CURRENT PROT.	D61	BIAS
Q4	+50V SW1	D71	RECT
Q5	RUSH FILTER	D81	LIMIT
Q6	SW	D82	GATE
Q7	+15V CURRENT PROT	D101	LEVEL SHIFT
Q9	-15V CURRENT PROT	D102	LEVEL SHIFT
Q10	SW	D103	LEVEL SHIFT
Q11	SW	D104	LEVEL SHIFT
Q12	I. PROT. SW3	D105	LEVEL SHIFT
Q13	I. PROT. SW2	D106	LEVEL SHIFT
Q101	R-V HEAD + POWER	D111	GATE 1
Q102	R-V HEAD - POWER	D112	GATE 7
Q103	G-V HEAD + POWER	D113	GATE 2
Q104	G-V HEAD - POWER	D114	GATE 8
Q105	B-V HEAD + POWER	D115	GATE 3
Q106	B-V HEAD - POWER	D116	GATE 9
Q301	FAN STOP 1	D201	LEVEL SHIFT
Q302	R-H SUB BUFF-3	D202	LEVEL SHIFT
Q303	R-H SUB BUFF-4	D203	LEVEL SHIFT
Q304	R-H SUB BUFF-1	D204	LEVEL SHIFT
Q305	R-H SUB BUFF-2	D205	LEVEL SHIFT
Q306	R-H ACTIVE LOAD	D206	LEVEL SHIFT
Q307	R-H SUB DRIVE	D211	+P VOLT GATE 2
Q308	G-H SUB BUFF-3	D212	+P VOLT GATE 1
Q309	G-H SUB BUFF-4	D213	-P VOLT GATE 2
Q310	G-H SUB BUFF-1	D214	-P VOLT GATE 1
Q311	G-H SUB BUFF-2	D215	+P VOLT GATE 2
Q312	G-H ACTIVE LOAD	D216	+P VOLT GATE 1
Q313	G-H SUB DRIVE	D217	-P VOLT GATE 2
Q314	B-H SUB BUFF-3	D218	-P VOLT GATE 1
Q315	B-H SUB BUFF-4	D219	+P VOLT GATE 2
Q316	B-H ACTIVE LOAD	D220	+P VOLT GATE 1
Q317	B-H SUB DRIVE	D221	-P VOLT GATE 2
Q318	B-H SUB BUFF-1	D222	-P VOLT GATE 1
Q319	B-H SUB BUFF-2	D231	GATE 4
Q401	FAN STOP 2	D232	GATE 10
Q403	FAN STOP 3	D233	GATE 5
Q405	R-V SUB BUFF-3	D234	GATE 11
Q406	R-V SUB BUFF-4	D235	GATE 6
Q407	R-V SUB BUFF-1	D236	GATE 12
Q408	R-V SUB BUFF-2	D302	R-H BIAS 1
Q409	R-V ACTIVE LOAD	D303	R-H BIAS 2
Q410	R-V SUB DRIVE	D306	BIAS
Q411	G-V SUB BUFF-3	D307	LEVEL SHIFT
Q412	G-V SUB BUFF-4	D308	G-H BIAS 1
Q413	G-V SUB BUFF-1	D309	G-H BIAS 2
Q414	G-V SUB BUFF-2	D312	BIAS
Q415	G-V ACTIVE LOAD	D313	LEVEL SHIFT
Q416	G-V SUB DRIVE	D314	B-H BIAS 1
Q417	B-V SUB BUFF-3	D315	B-H BIAS 2
Q418	B-V SUB BUFF-4	D318	BIAS
Q419	B-V SUB BUFF-1	D319	LEVEL SHIFT
Q420	B-V SUB BUFF-2	D403	R-V BIAS 1
Q421	B-V ACTIVE LOAD	D404	R-V BIAS 2
Q422	B-V SUB DRIVE	D407	BIAS
		D408	LEVEL SHIFT
		D409	R-V BIAS 1
		D410	R-V BIAS 2
D5	DISCHARGE	D413	BIAS
D8	DISCHARGE	D414	LEVEL SHIFT
D9	GATE	D415	B-V BIAS 1
D10	GATE	D416	B-V BIAS 2
D11	GATE	D419	BIAS
D12	DISCHARGE	D420	LEVEL SHIFT
D13	GATE		

DC BOARD

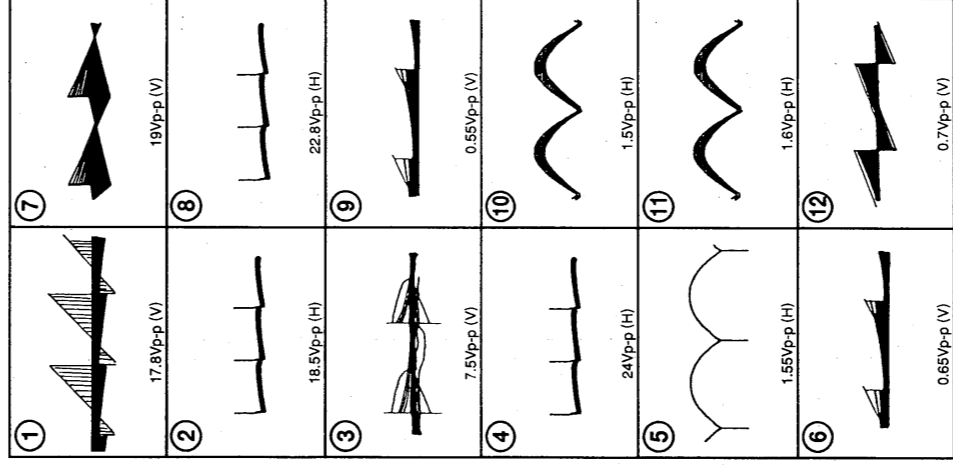

SCHEMATIC DIAGRAMS AND PRINTED WIRING BOARDS

DD BOARD

The following diagram has been divided into 3 sections as noted on the grid shown below.

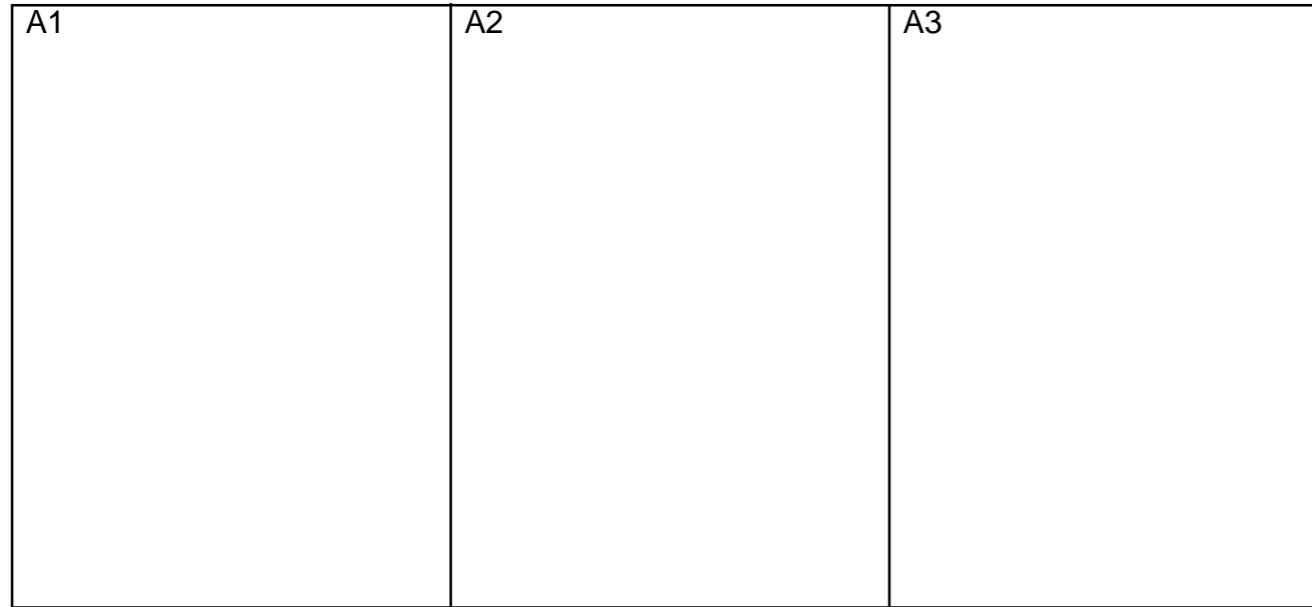

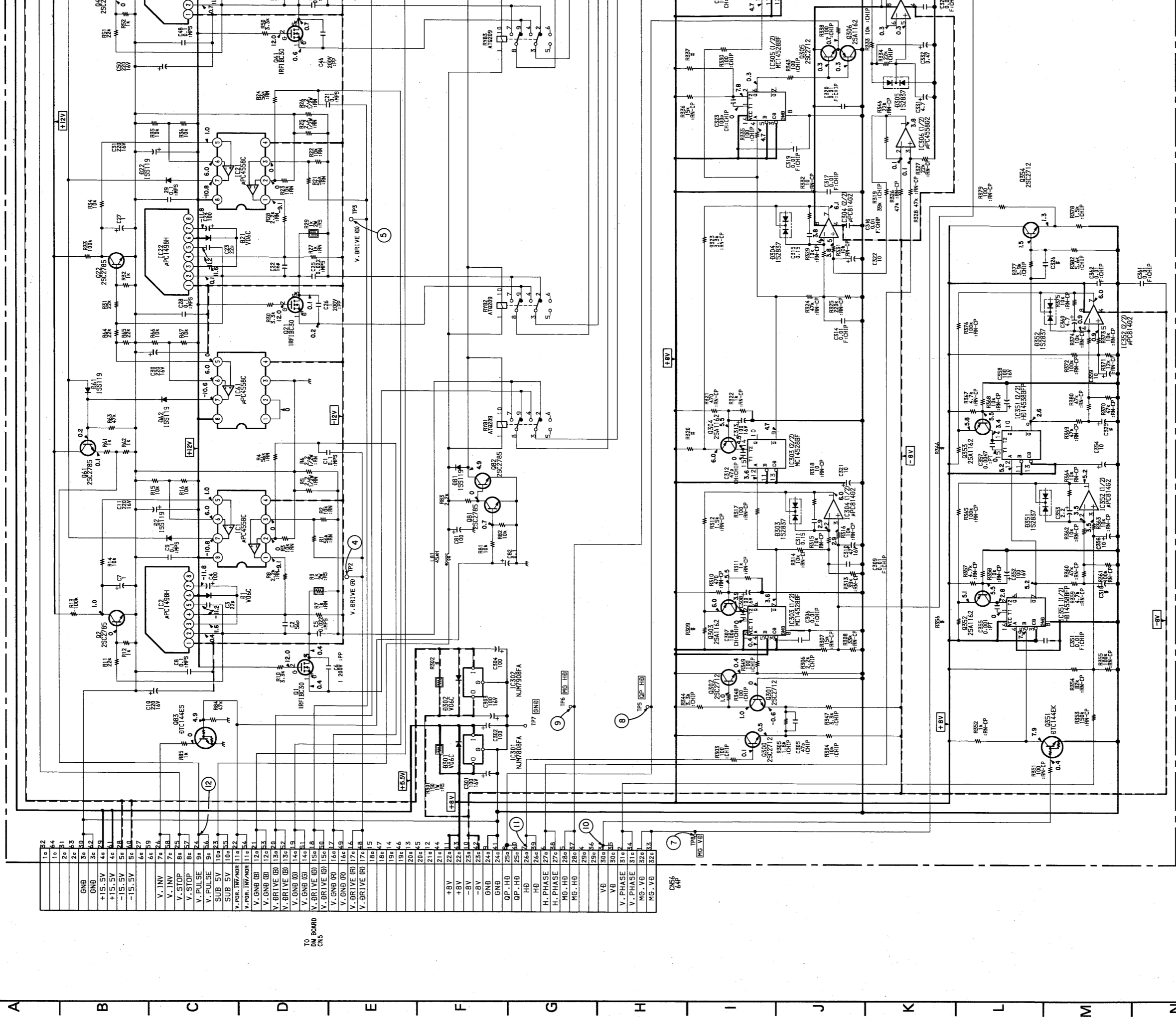

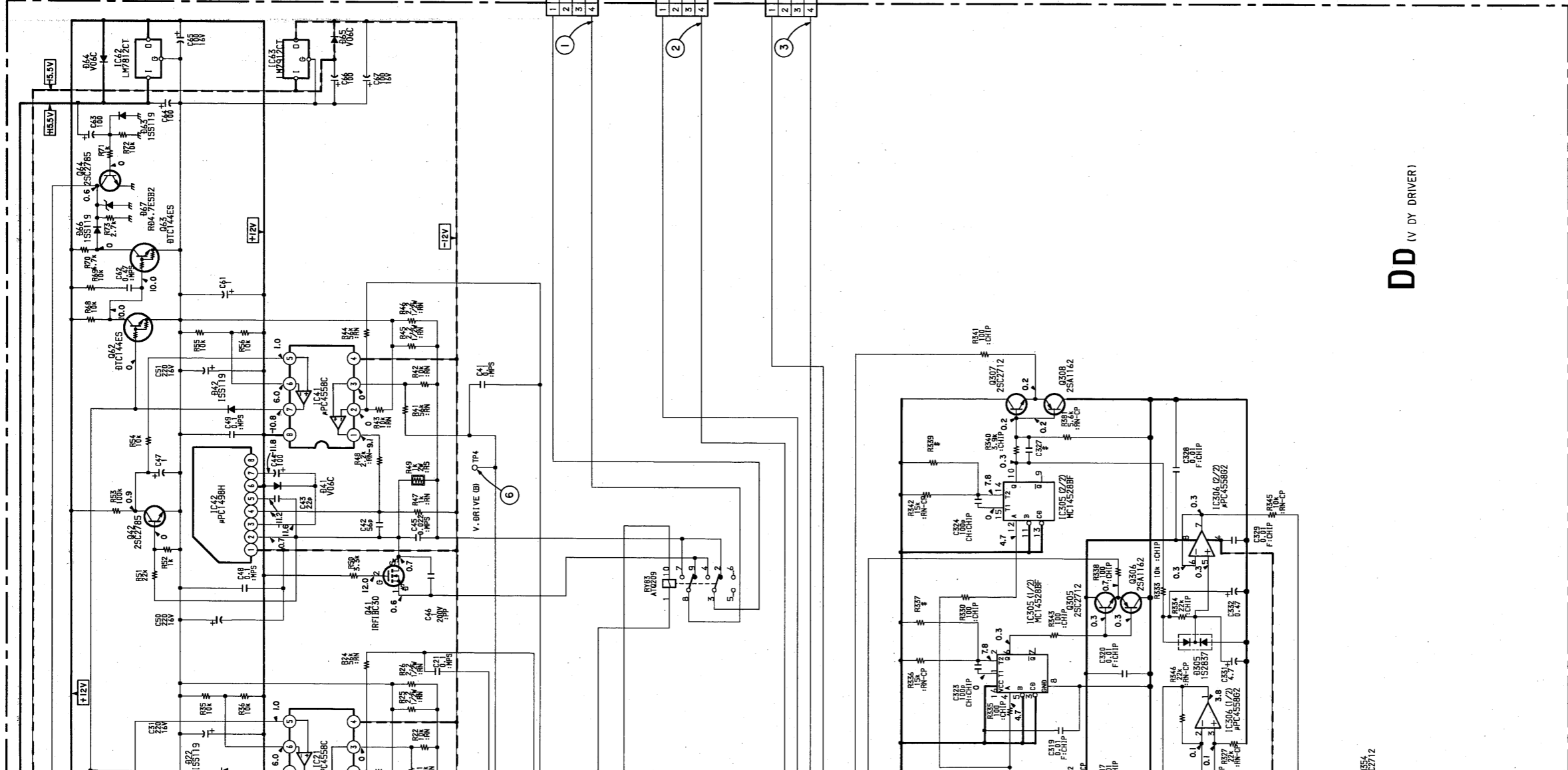

DD (V DY DRIVER)

DD BOARD

IC1	R-V AMP
IC2	R-V OUT
IC21	G-V AMP
IC22	G-V OUT
IC41	B-V AMP
IC42	B-V OUT
IC61	V PULSE GEN.
IC62	+12V REG.
IC63	-12V REG.
IC301	+8V REG.
IC302	-8V REG.
IC303	HD SHIFT GEN-1
IC304	HD SHIFT COMP.
IC305	HD SHIFT GEN-2
IC306	HD F-V CONV.
IC351	VD SHIFT GEN-1
IC352	VD SHIFT COMP.
Q1	R-RP
Q2	V. PULSE DET-1
Q21	G-V RP
Q22	V. PULSE DET-2
Q41	B-V RP
Q42	V. PULSE DET-3
Q61	V. PULSE BUFF.
Q62	V. STOP CONT. SW-1
Q63	V. STOP CONT. SW-2
Q64	V. STOP CONT. SW-3
Q81	V. POR SW-1
Q82	V. POR SW-2
Q83	V. INV. SW
Q300	HD BUFF-1
Q301	HD AMP
Q302	HD BUFF-2
Q303	V-I CONV-1
Q304	V-I CONV-2
Q305	QP HD BUFF-1
Q306	QP HD BUFF-2
Q307	MG HD BUFF-1
Q308	MG HD BUFF-2
Q351	VD INV.
Q352	V-I CONV-1
Q353	V-I CONV-2
Q354	MG VD BUFF.
D1	PULSE CHARGE-1
D2	GATE-1
D21	PULSE CHARGE-2
D22	GATE-2
D41	PULSE CHARGE-3
D42	GATE-3
D61	GATE-4
D62	GATE-5
D63	V. STOP CLAMP
D64	+12V REG. PROT.
D65	-12V REG. PROT.
D66	GATE-6
D67	V. STOP ZENER
D81	RY PROT.
D301	REG. PROT-1
D302	REG. PROT-2
D303	HD SHIFT LIMIT-1
D304	HD SHIFT LIMIT-2
D305	SPEED UP
D351	VD SHIFT LIMIT-1
D352	VD SHIFT LIMIT-2

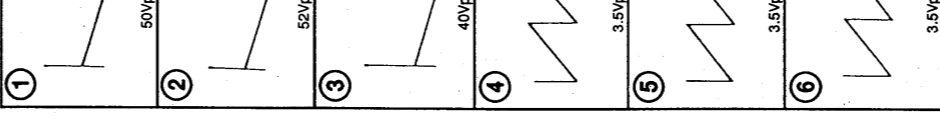

DD [V. DY DRIVER]

DD BOARD

IC	
IC1	B-6
IC2	C-6
IC21	B-4
IC22	C-4
IC41	B-2
IC42	C-2
IC61	D-1
IC62	E-2
IC63	E-3
IC301	C-10
IC302	D-10
IC303	C-9
IC304	D-8
IC305	A-8
IC306	C-7
IC351	B-9
IC352	B-10

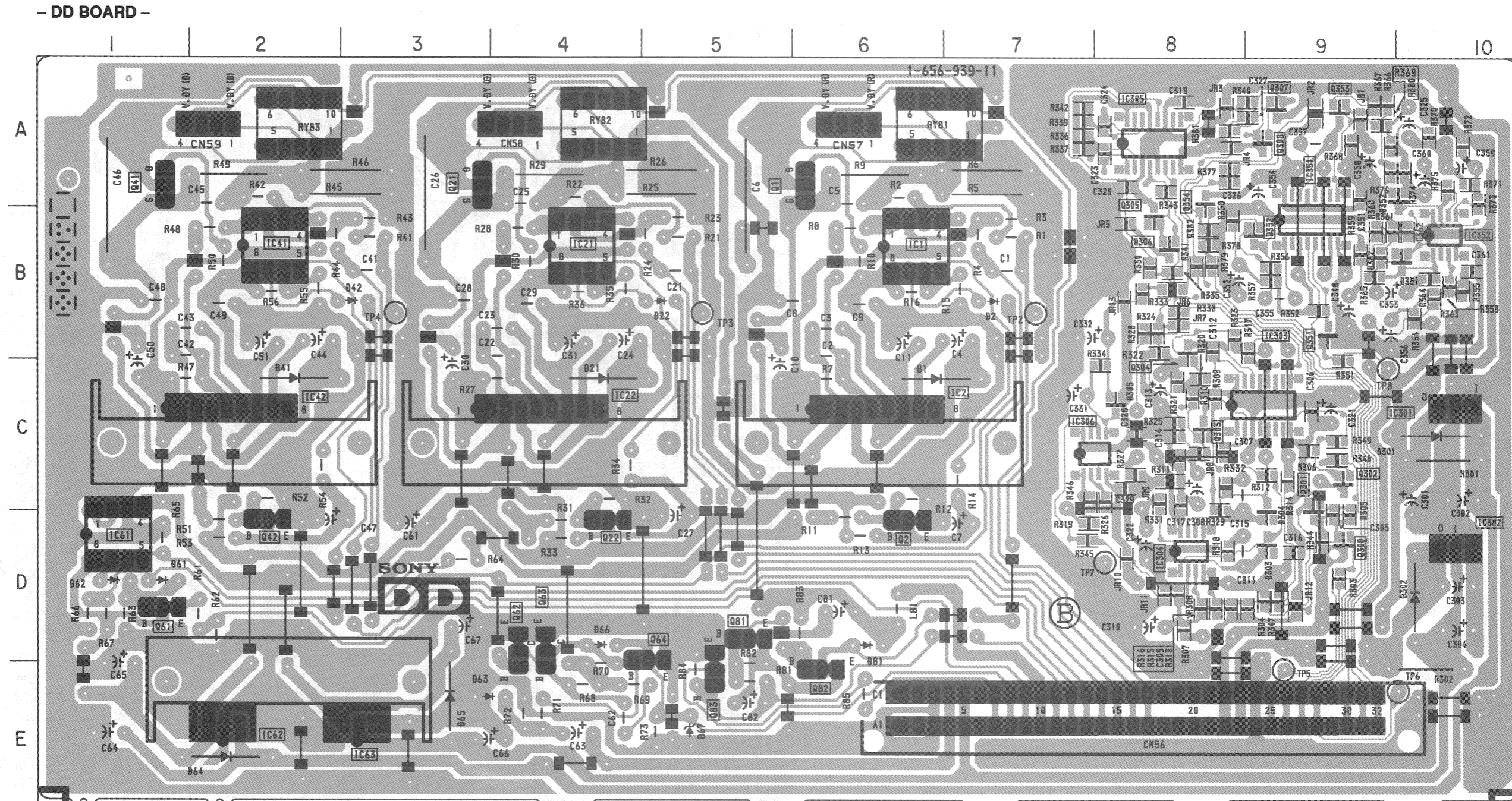

TRANSISTOR	
Q1	A-6
Q2	D-6
Q21	A-3
Q22	D-4
Q41	A-1
Q42	D-2
Q61	D-1
Q62	D-4
Q63	D-4
Q64	D-5
Q81	D-5
Q82	E-6
Q83	E-5
Q300	D-9
Q301	C-9
Q302	C-9
Q303	C-8
Q304	C-8
Q305	B-8
Q306	B-8
Q307	A-9
Q308	A-9
Q351	B-9
Q352	B-9
Q353	A-9
Q354	A-8

DIODE	
D1	C-6
D2	B-7
D21	C-4
D22	B-5
D41	C-2
D42	B-3
D61	D-1
D62	D-1
D63	E-3
D64	E-2
D65	E-3
D66	D-4
D67	E-5
D81	D-6
D301	C-10
D302	D-10
D303	D-9
D304	D-9
D305	C-8
D351	B-10
D352	A-9

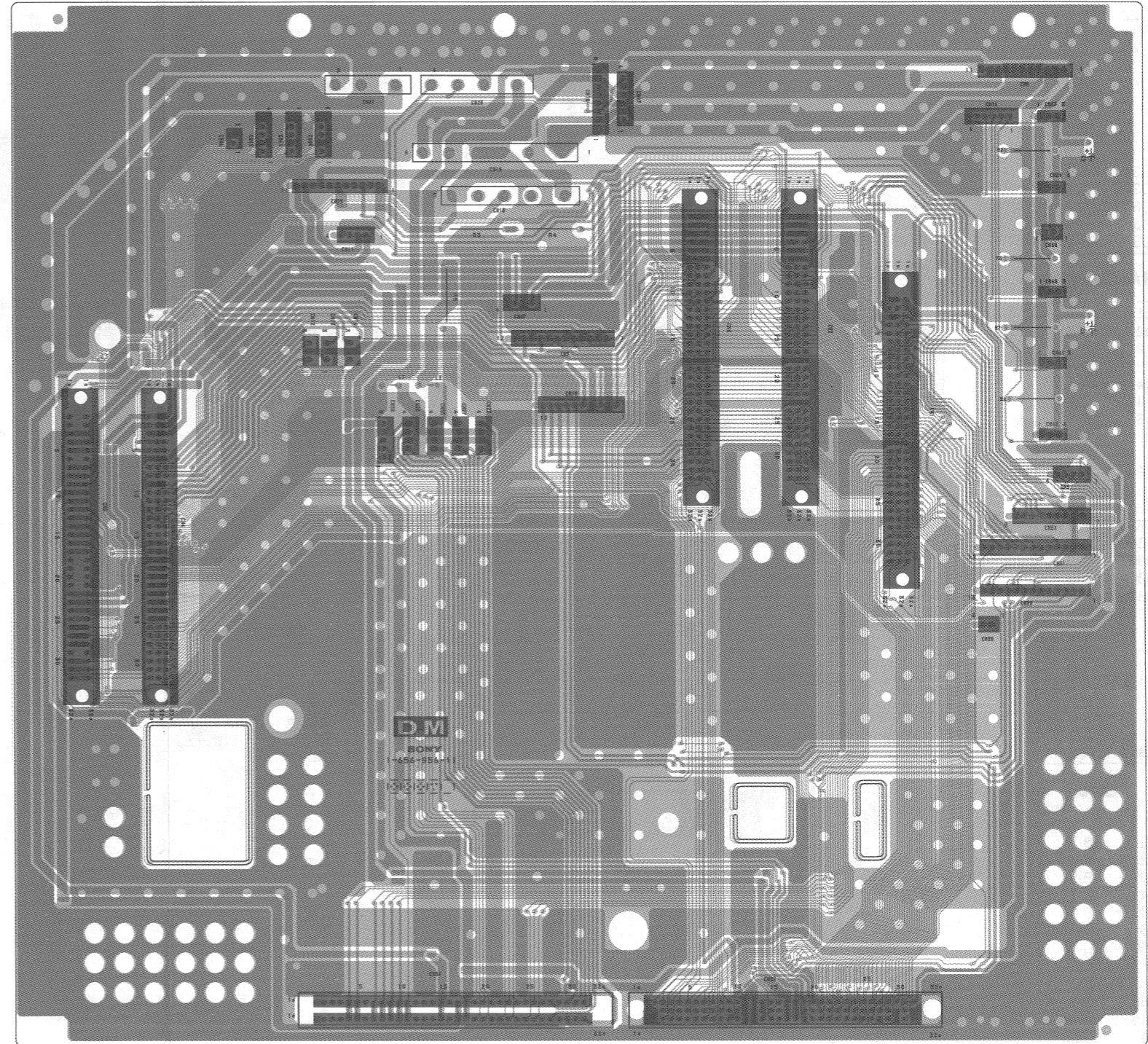

- DM BOARD -



-  : Pattern from the side which enables seeing.
-  : Pattern of the rear side.

SCHEMATIC DIAGRAMS AND PRINTED WIRING BOARDS

DM BOARD

The following diagram has been divided into 3 sections as noted on the grid shown below.

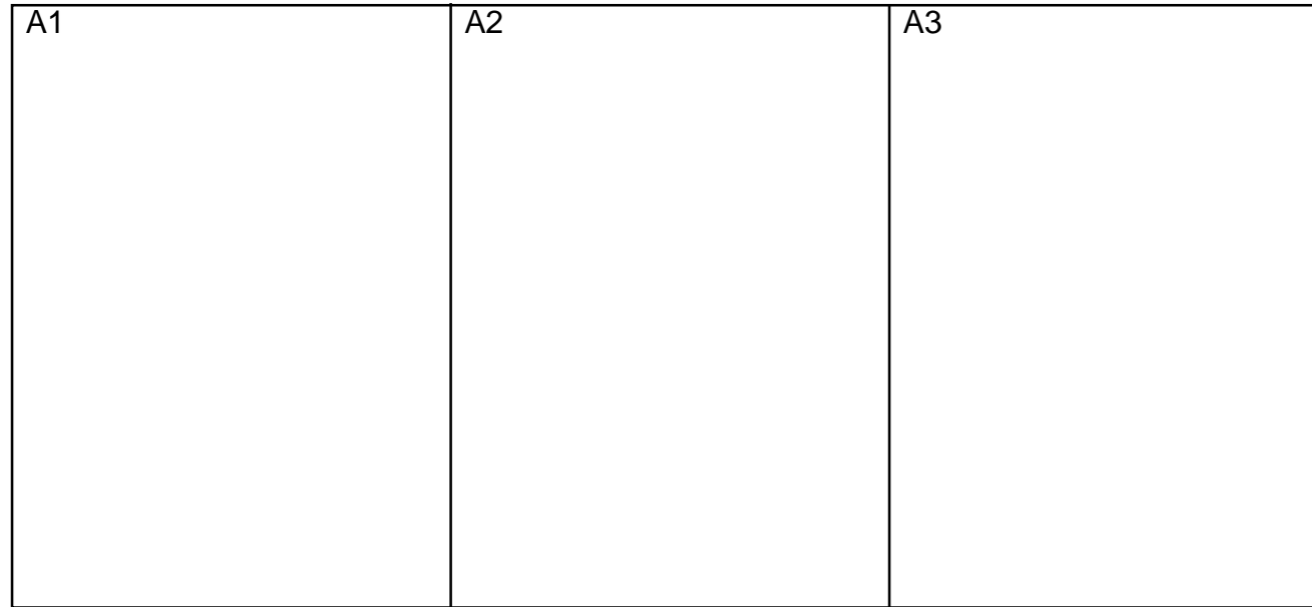

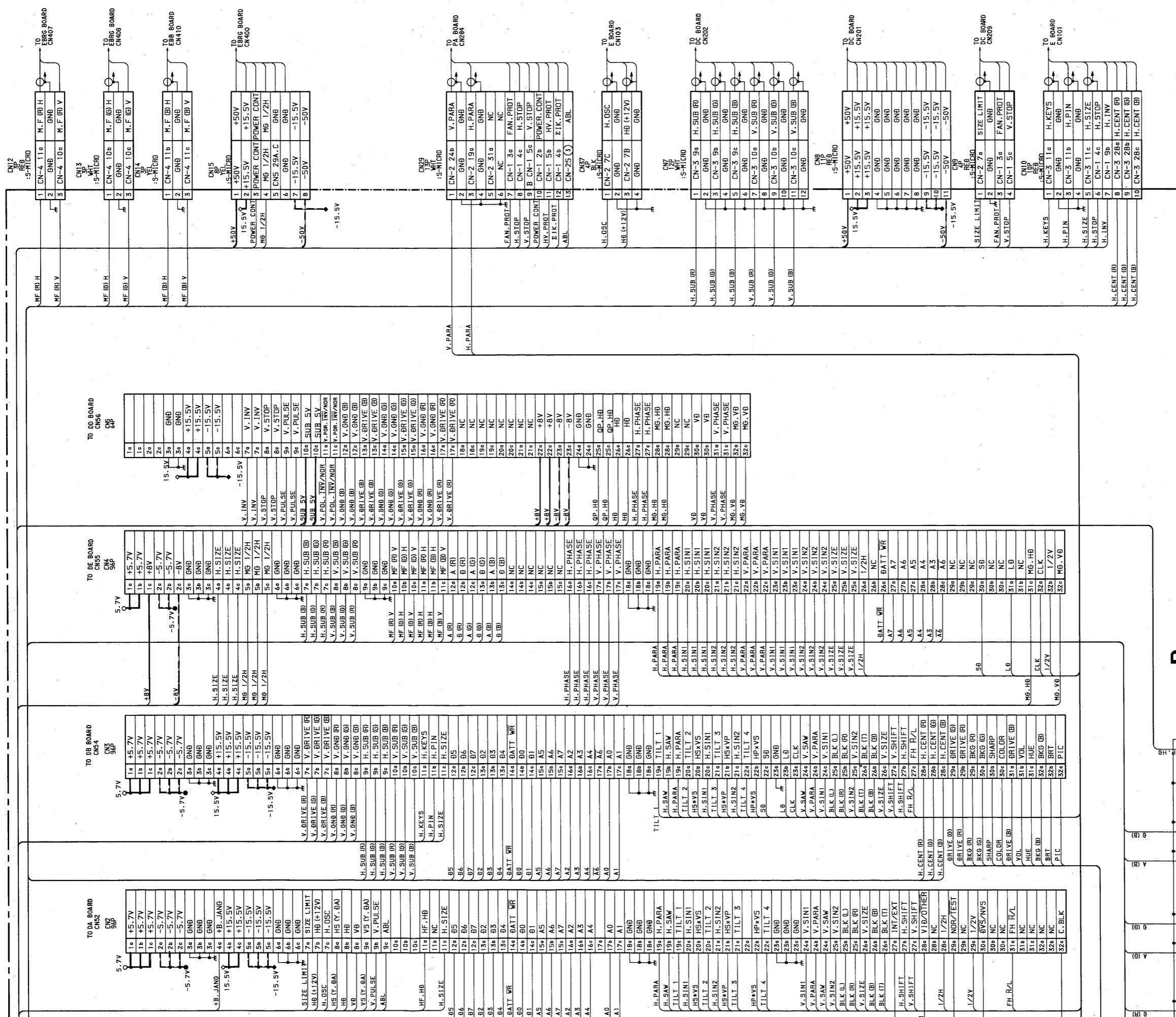

DM (MOTHER)

SCHEMATIC DIAGRAMS AND PRINTED WIRING BOARDS

Y BOARD

The following diagram has been divided into 3 sections as noted on the grid shown below.

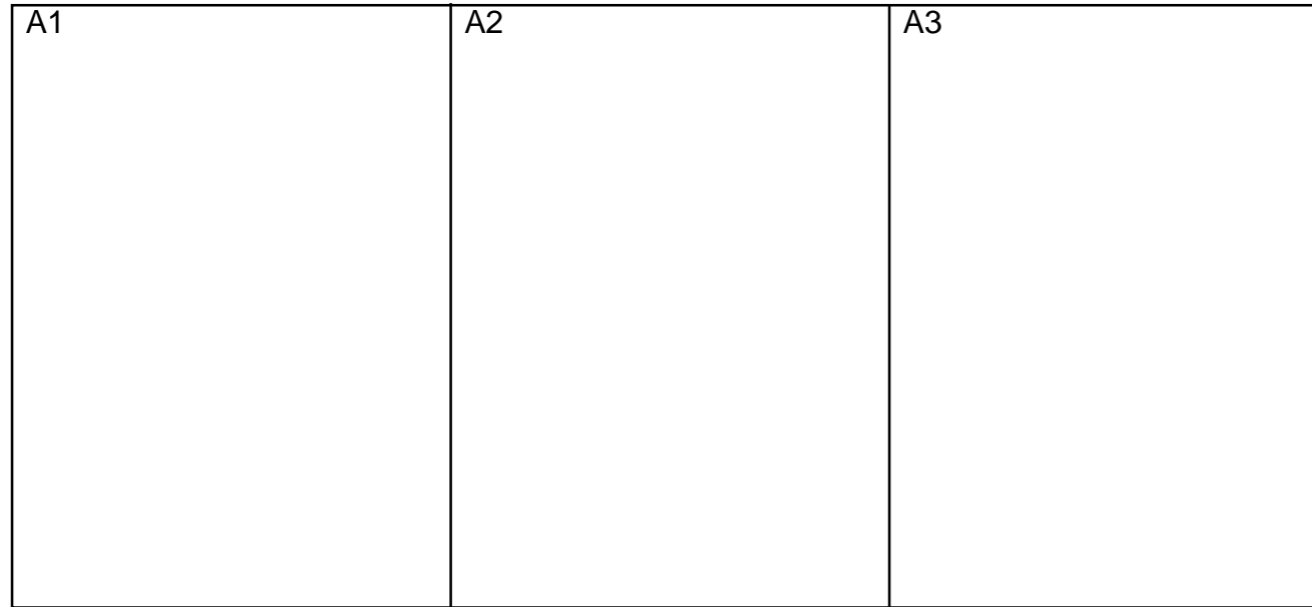

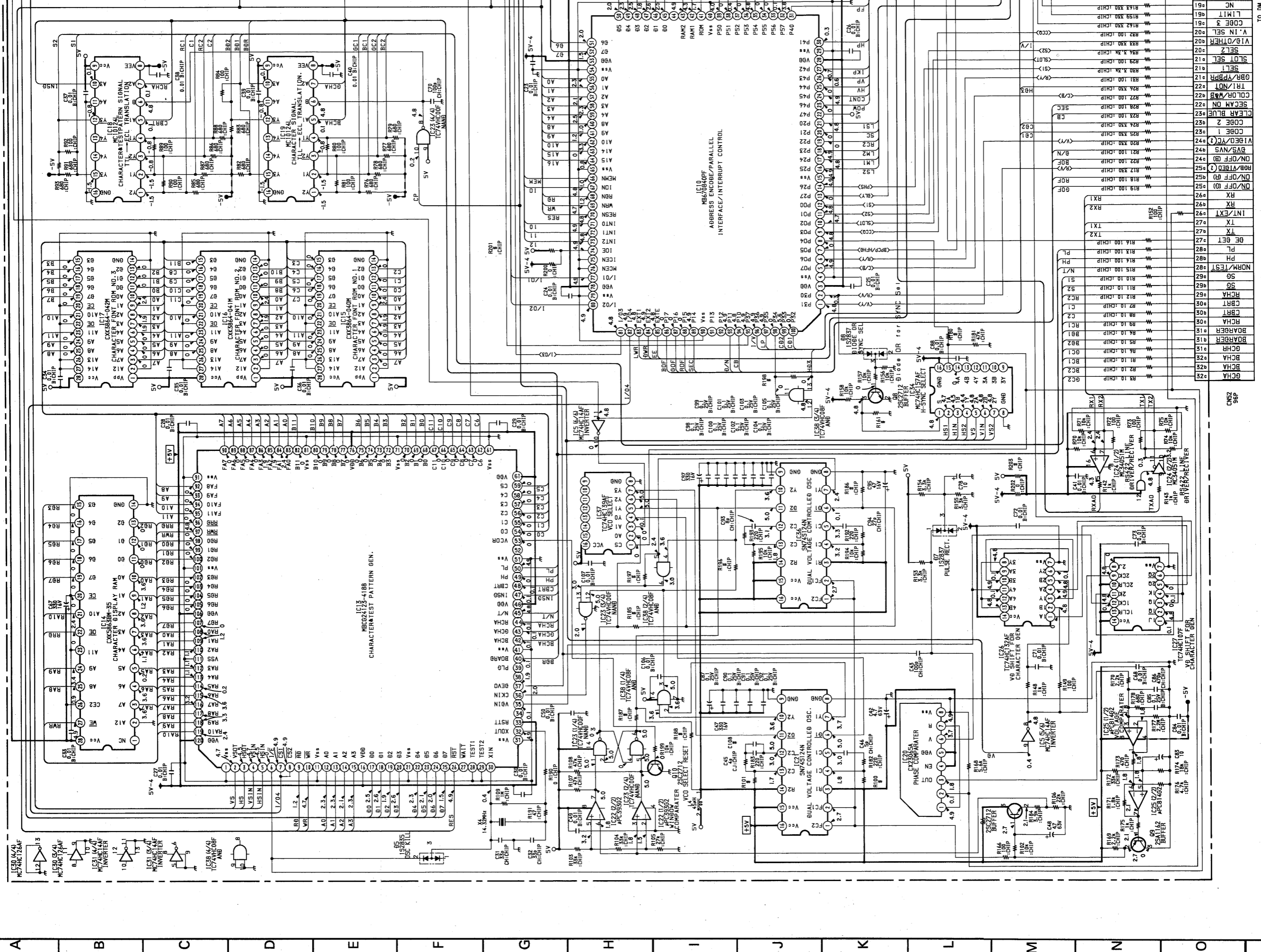

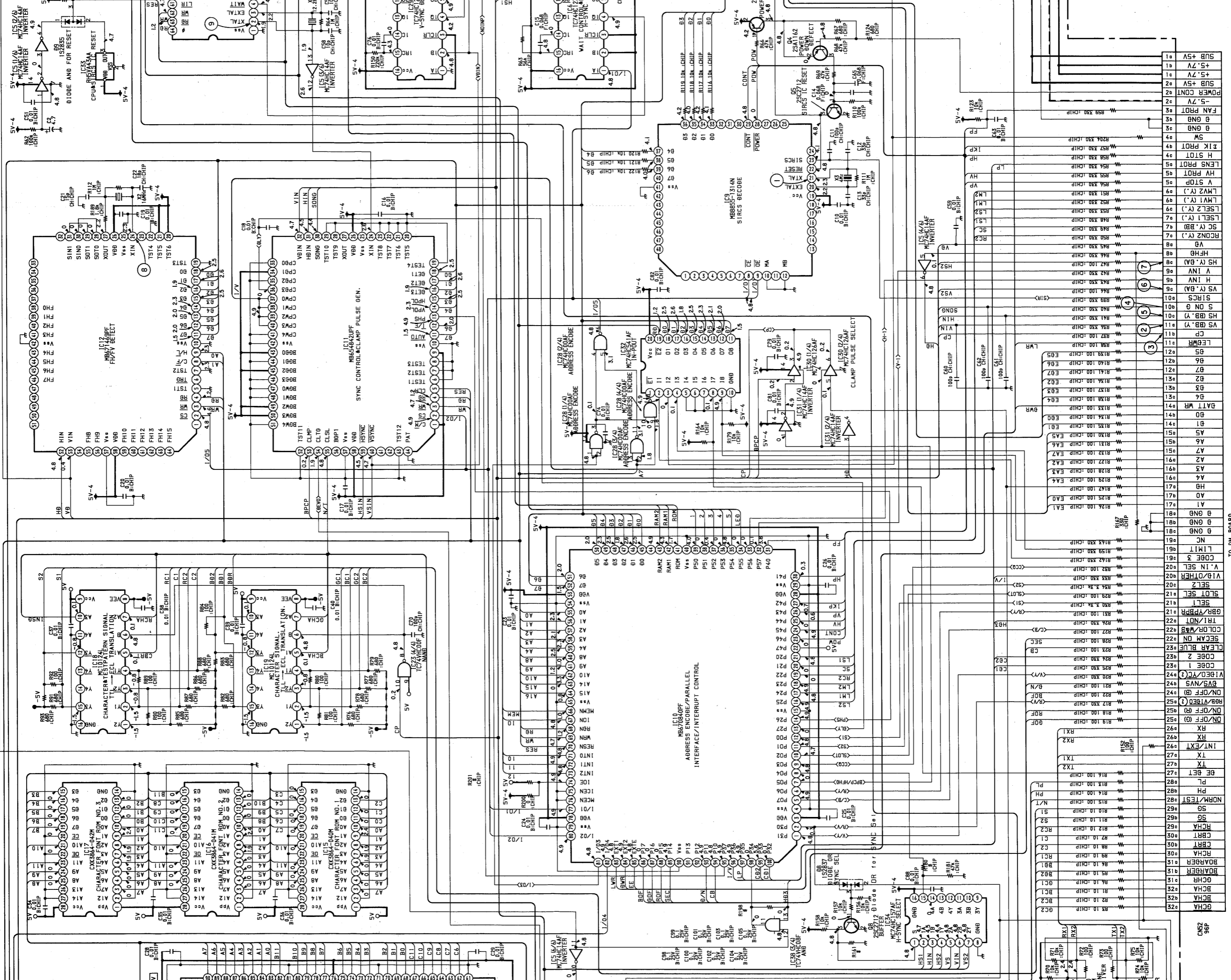

TO DM BOARD

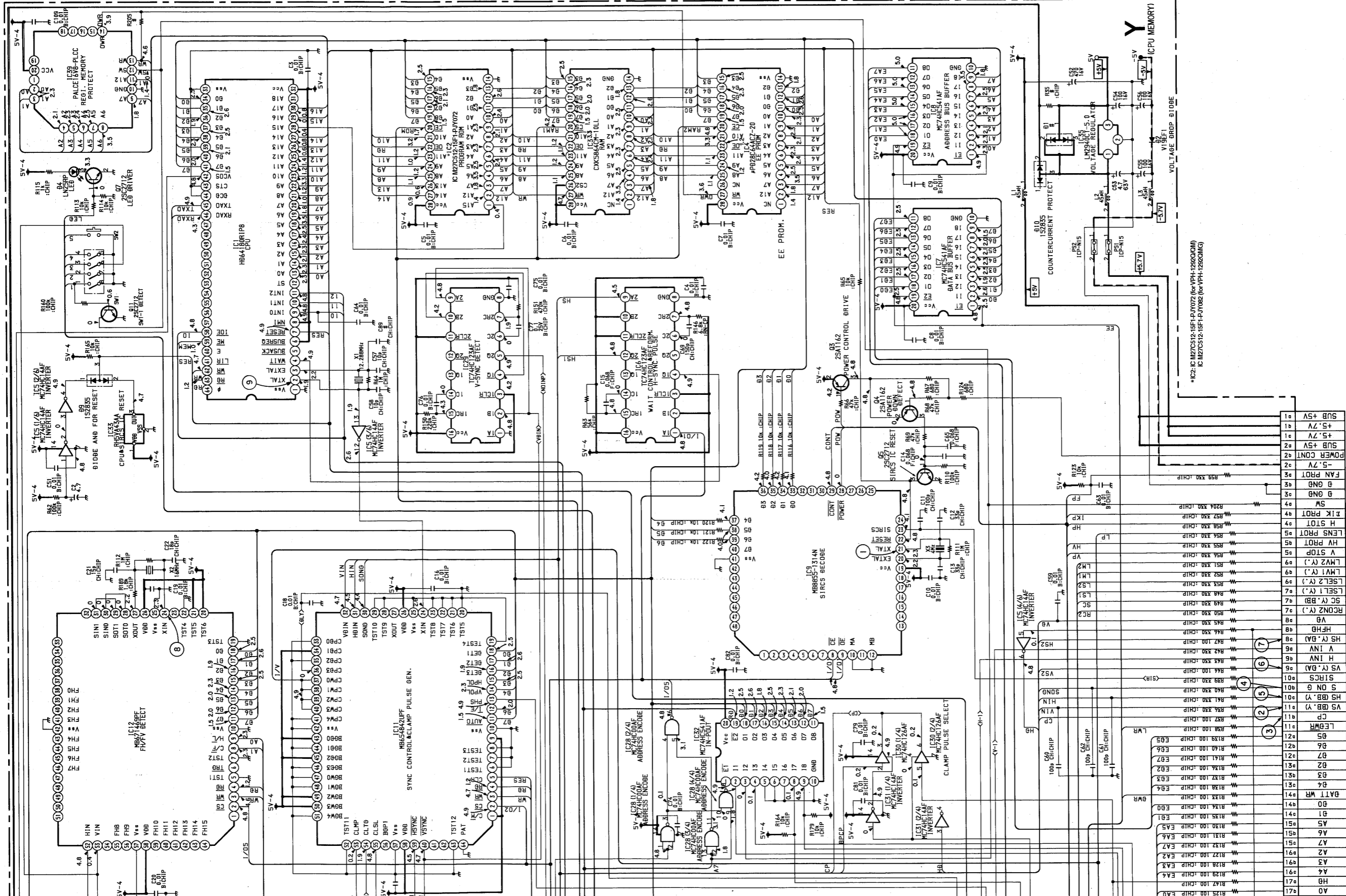

*IC2: IC M27C512-15F-PJY072 (for VPH-1290QIM)
 IC M27C512-15F-PJY082 (for VPH-1290QIM)



[CPU MEMORY]

- Y BOARD - <Component Side>

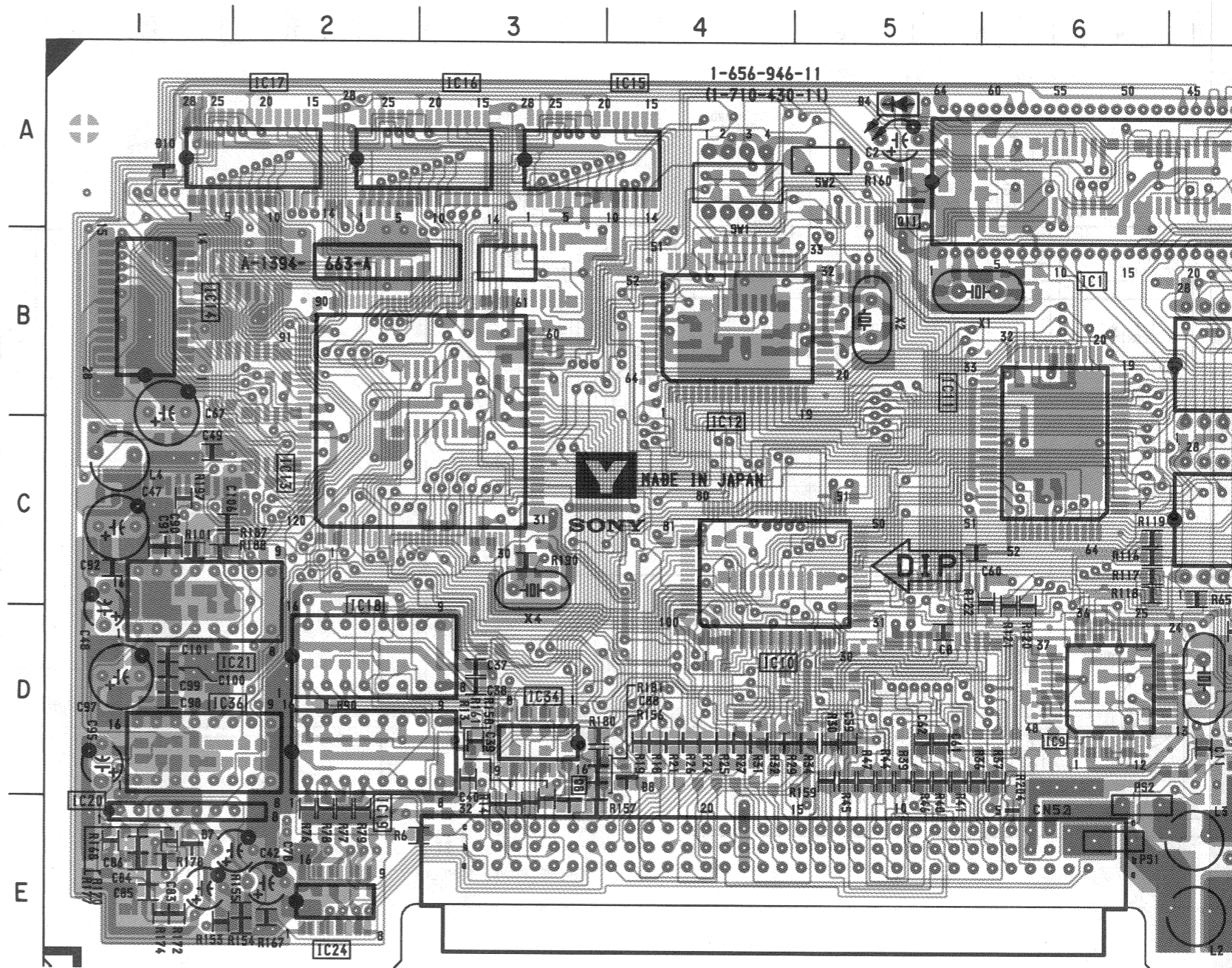

Y BOARD

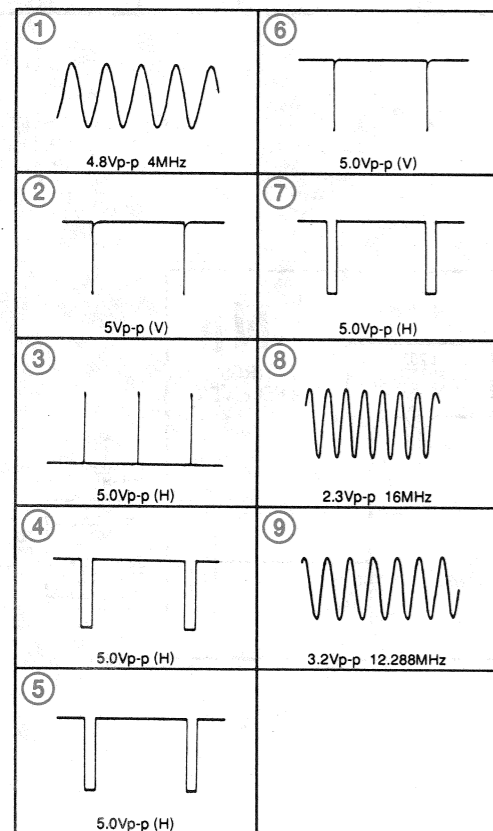

Y BOARD
(COMPONENT SIDE)

IC	
IC1	A-6
IC2	B-7
IC3	D-7
IC4	C-7
IC9	D-6
IC10	D-4
IC11	C-6
IC12	B-4
IC13	C-2
IC14	A-1
IC15	A-4
IC16	A-3
IC17	A-2
IC18	D-2
IC19	D-2
IC20	E-1
IC21	D-1
IC24	E-2
IC34	D-3
IC35	E-8
IC36	D-1
IC39	B-8

TRANSISTOR	
Q8	D-3
Q11	A-5

DIODE	
D2	D-8
D4	A-5
D7	E-1
D8	D-4
D10	A-1

<Conductor Side>

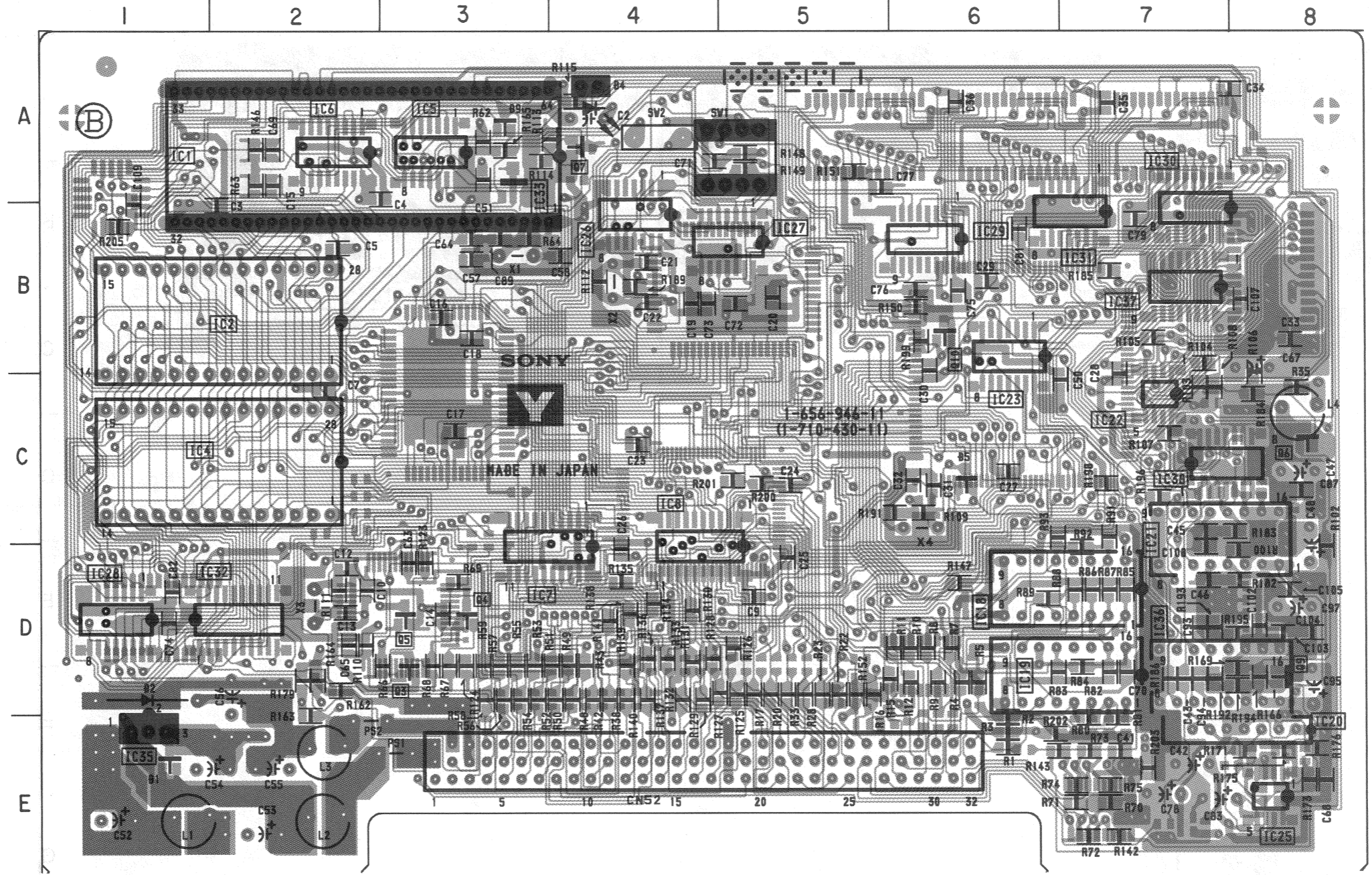
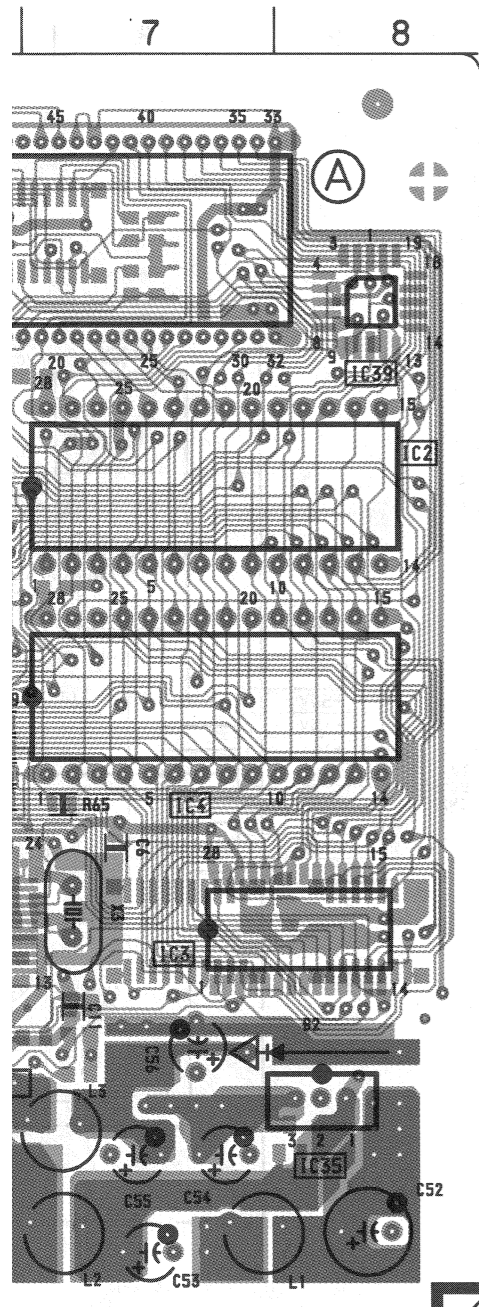

Y BOARD
(CONDUCTOR SIDE)

IC

IC1	A-2
IC2	B-1
IC4	C-1
IC5	A-3
IC6	A-2
IC7	D-3
IC8	D-4
IC18	D-6
IC19	D-6
IC20	E-8
IC21	C-7
IC23	B-6
IC25	E-8
IC26	B-4
IC27	B-5
IC28	D-1
IC29	B-6
IC30	A-7
IC31	B-7
IC32	D-1
IC33	A-3
IC35	E-1
IC36	D-7
IC37	B-7
IC38	C-7

TRANSISTOR

Q3	D-3
Q4	D-3
Q5	D-3
Q6	C-8
Q7	A-4
Q9	D-8
Q10	B-6

DIODE

D2	D-1
D4	A-4
D5	C-6
D9	A-3

• : Pattern from the side which enables seeing.
• : Pattern of the rear side.

DG

[H. SUB POWER SUPPLY]

NA

[RECEIVER]

NB

[SIRCS RECEIVER]

- DG BOARD -

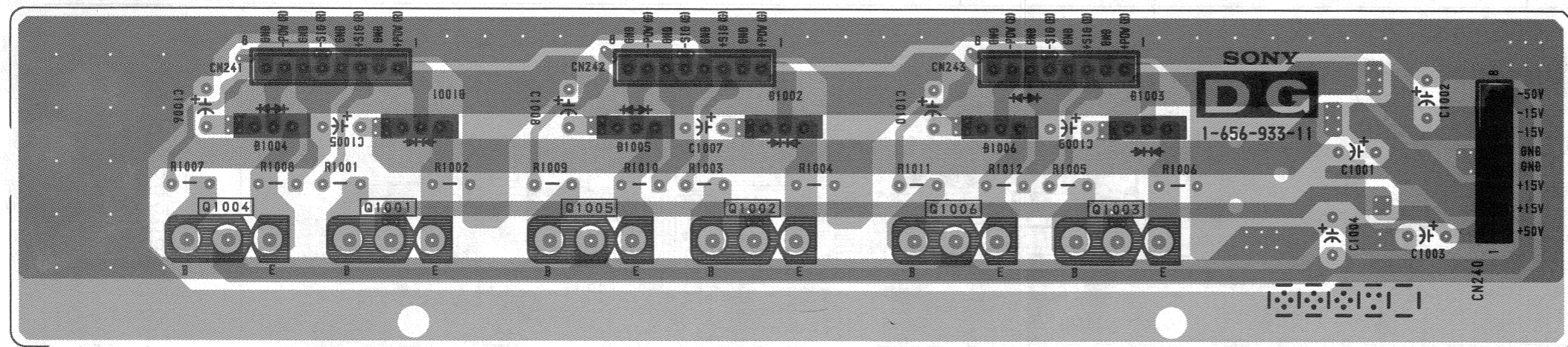

- : Pattern from the side which enables seeing.
- : Pattern of the rear side.

- NA BOARD -

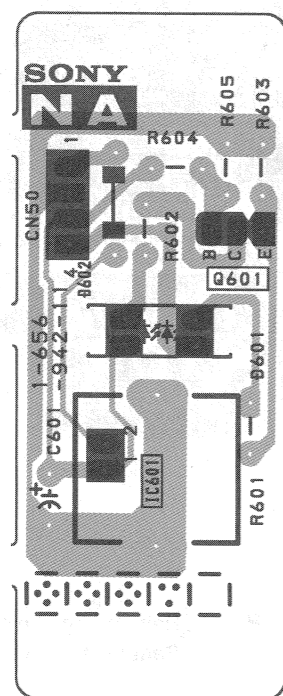

- NB BOARD -

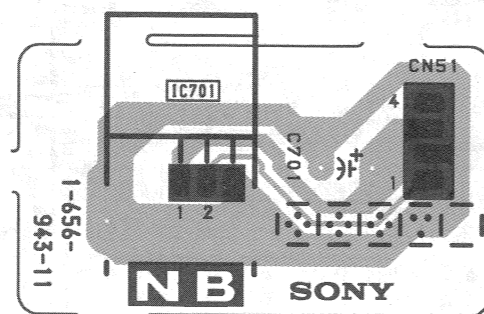

Schematic diagrams

DG, **NA**, **NB** boards →

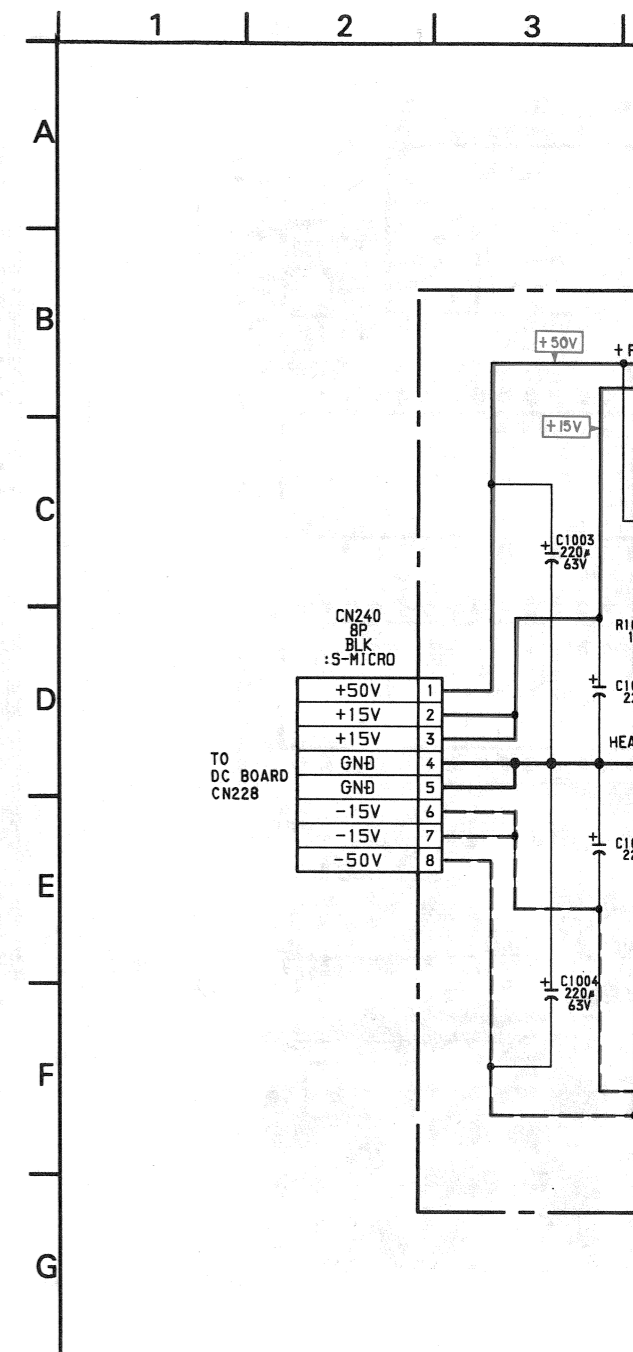

4 | 5 | 6 | 7 | 8 | 9 | 10 | 11 | 12 | 13 | 14 | 15 | 16 | 17 | 18

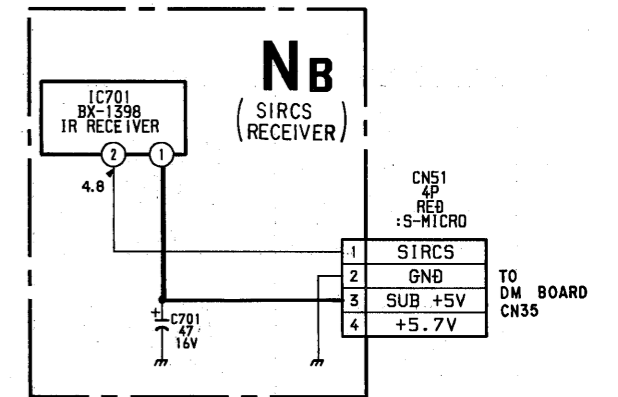
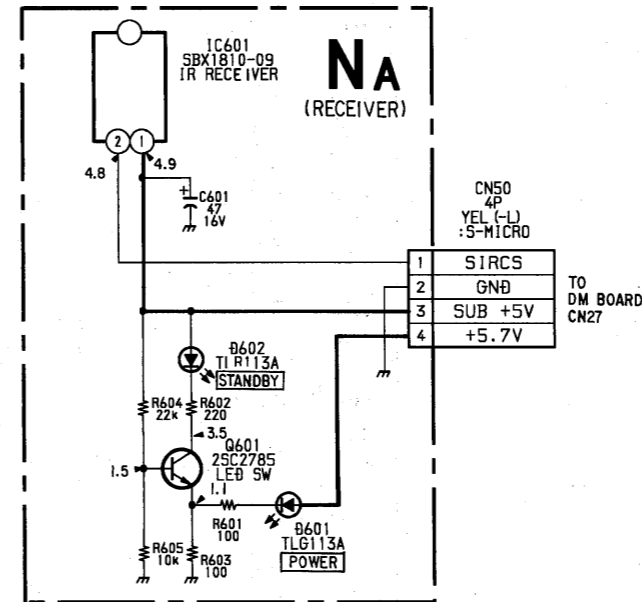
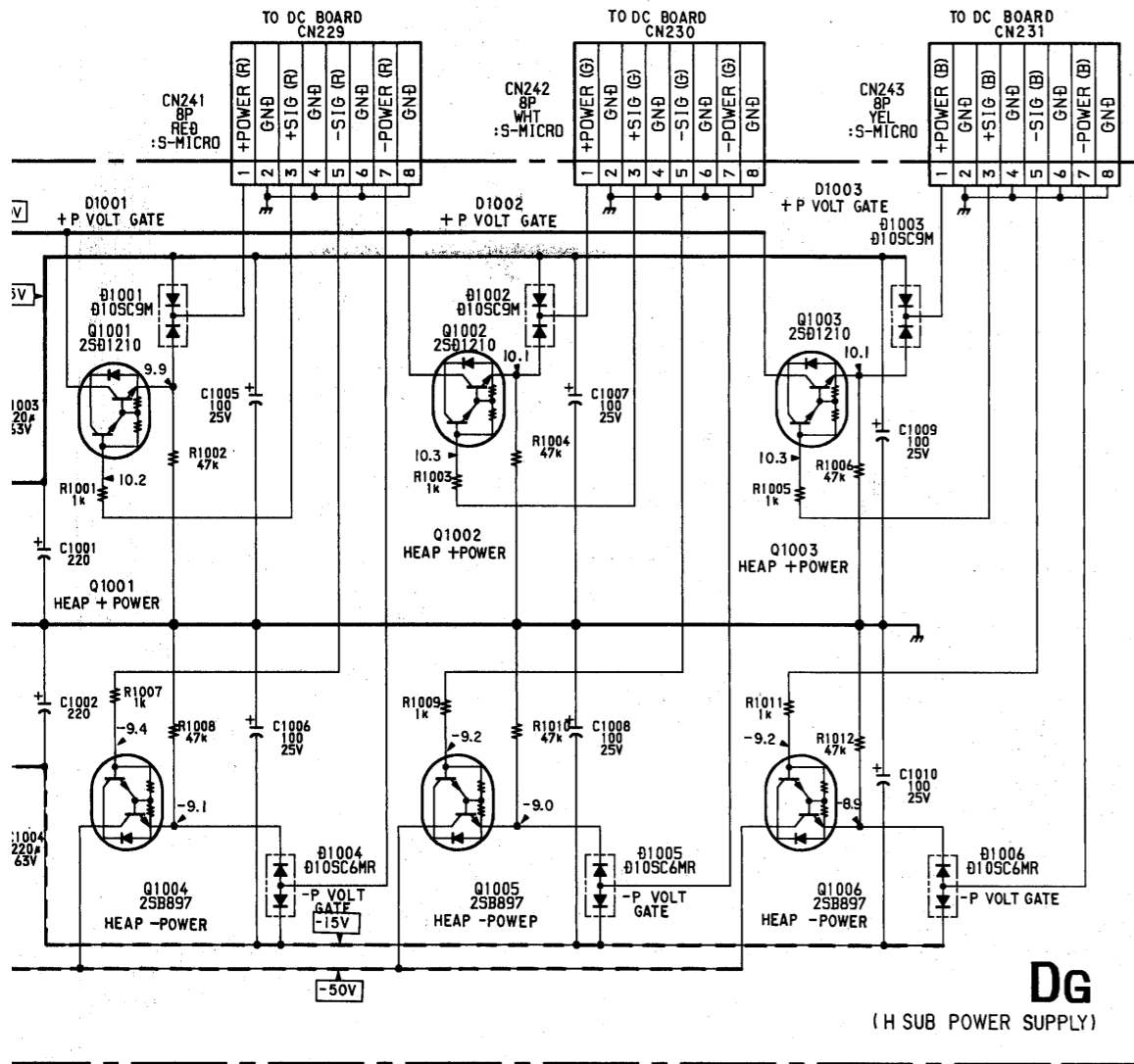

EA

- EA BOARD -

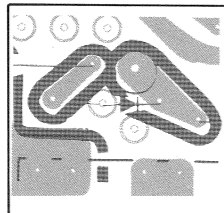
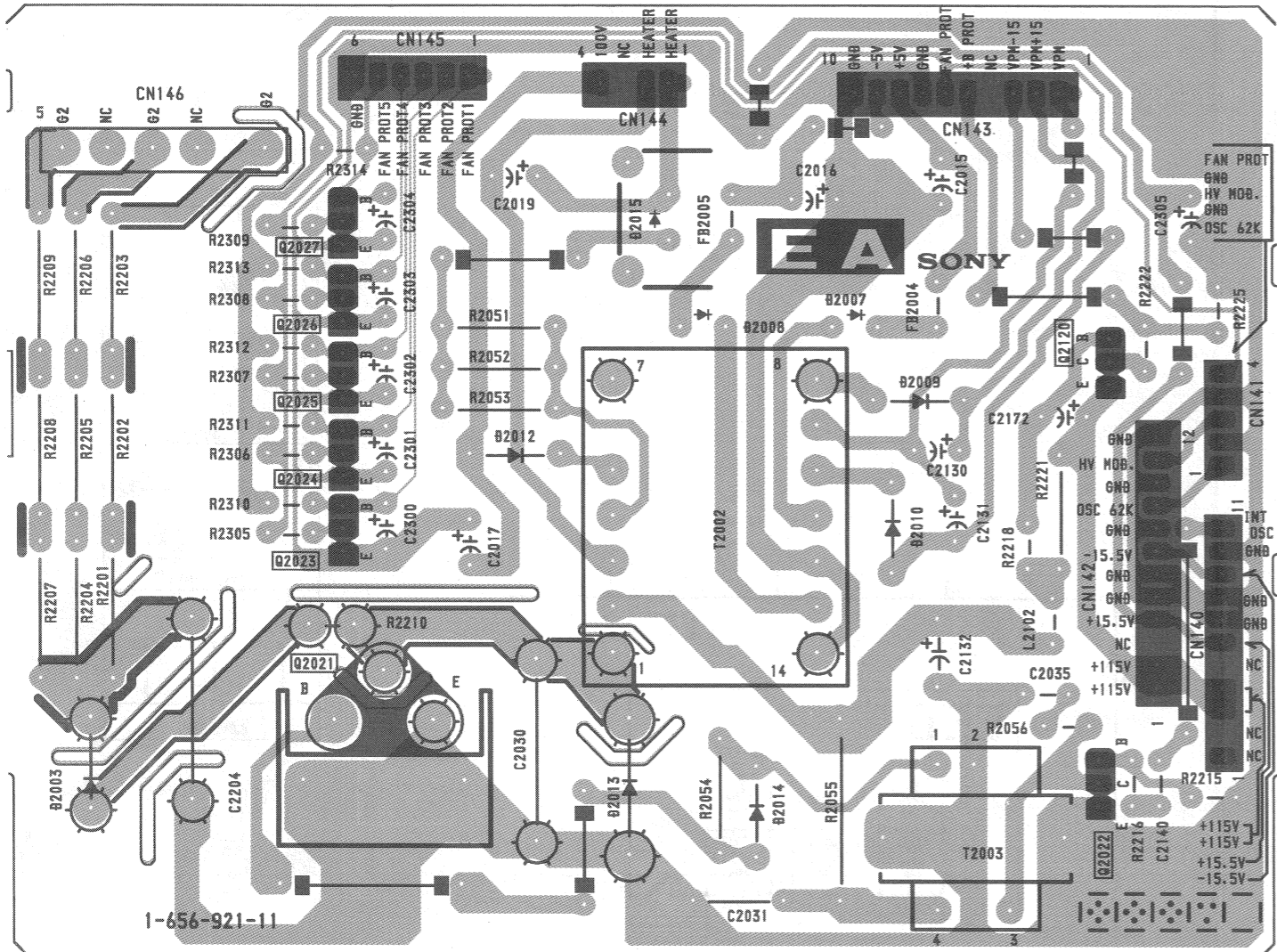

NOTE:
The circuit indicated as left contains high voltage of over 600 Vp-p. Care must be paid to prevent an electric shock in inspection or repairing.

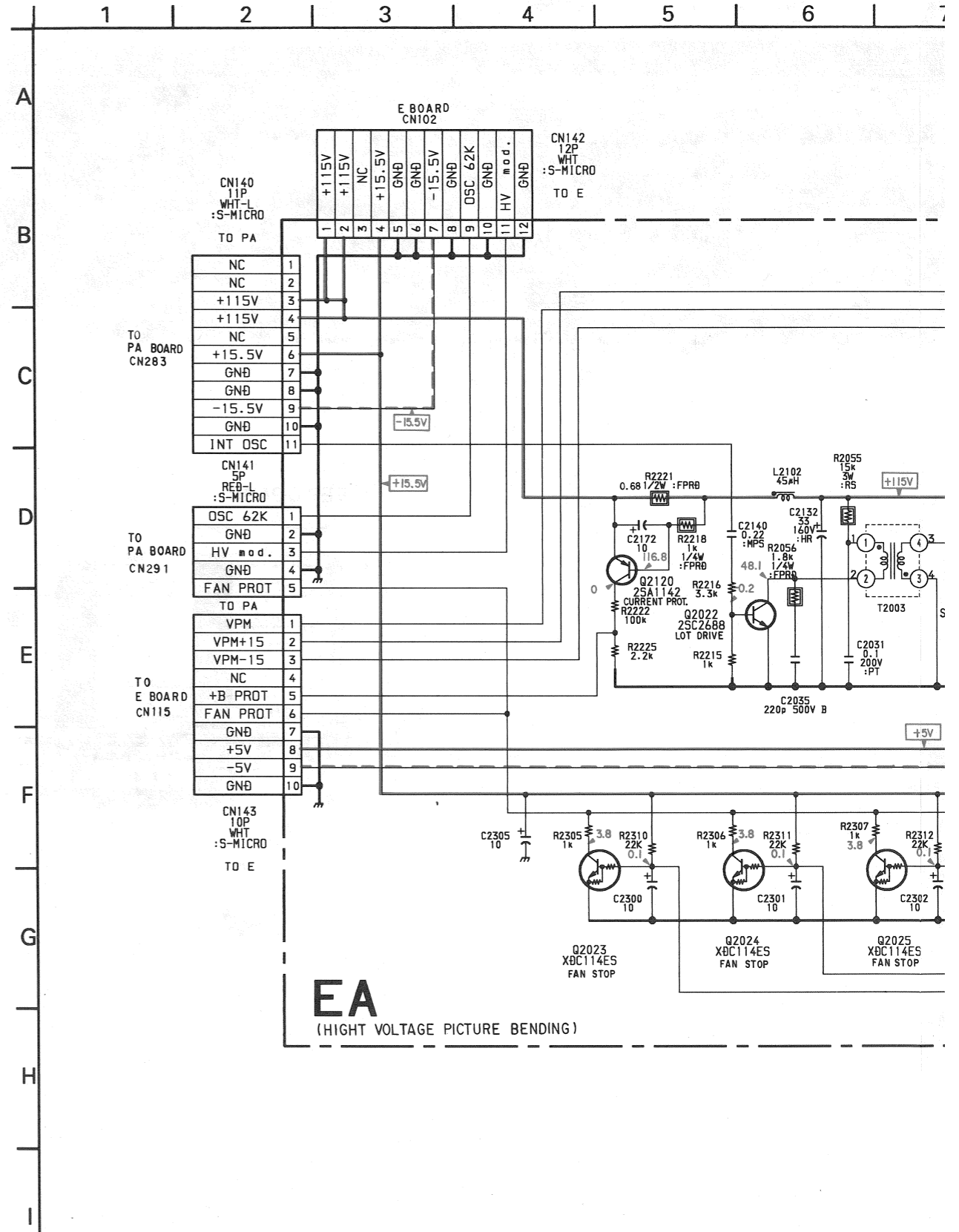

EA
(HIGHT VOLTAGE PICTURE BENDING)

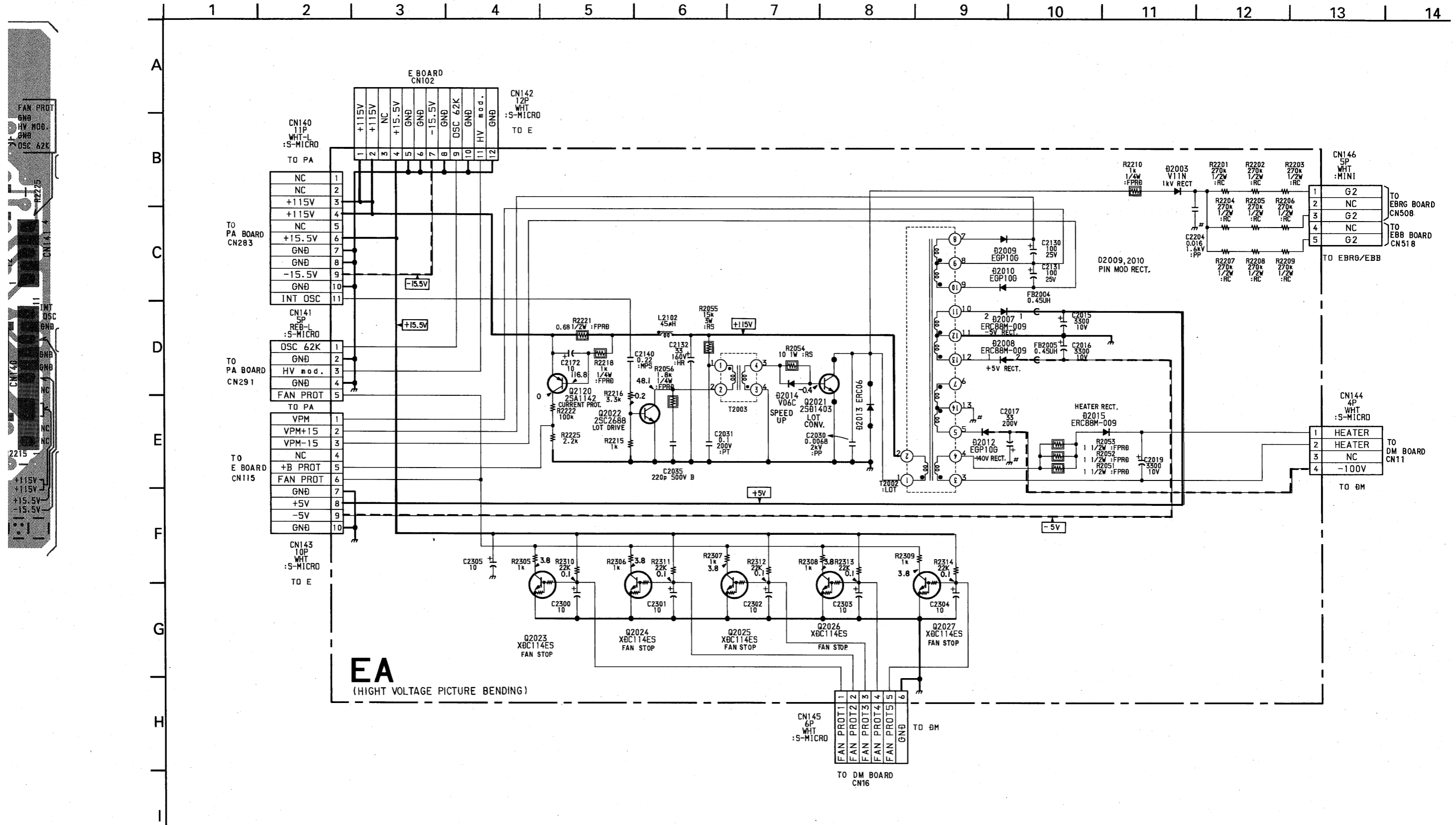

Schematic diagram

← EA board

Schematic diagram

EEB board →

EEA

EEB

- EEA BOARD -

EEA BOARD

IC	
IC2004	A-9
IC2101	A-1
IC2103	A-2
IC2104	B-3
IC2105	A-3
IC2106	B-5
IC2107	A-7
IC2108	A-8
IC2110	B-9
IC2111	A-4
IC2118	A-6
TRANSISTOR	
Q2101	B-1
Q2103	A-8
Q2104	A-8
Q2129	A-5
Q2152	B-6
Q2153	B-6
Q2154	B-6
DIODE	
D2020	A-9
D2103	A-8
D2104	B-8
D2105	B-9
D2120	B-4
D2131	B-1
D2132	B-1
D2143	B-1
VARIABLE RESISTOR	
RV2101	A-6

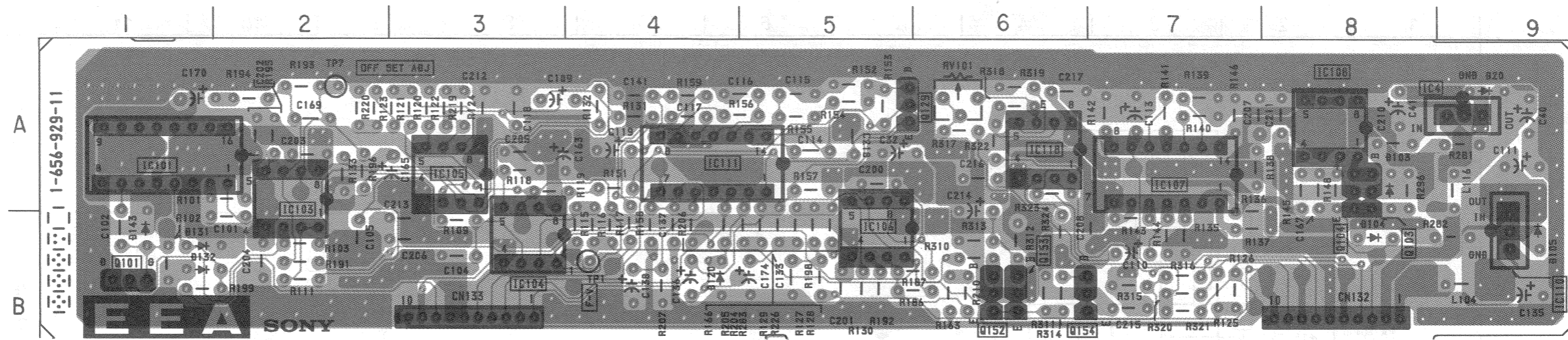

- : Pattern from the side which enables seeing.
- : Pattern of the rear side.

- EEB BOARD -

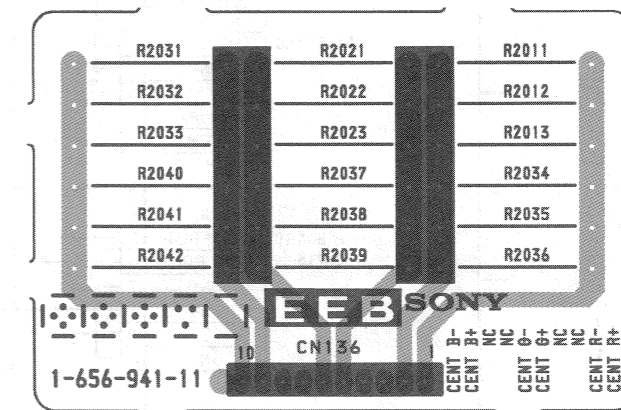

EEB

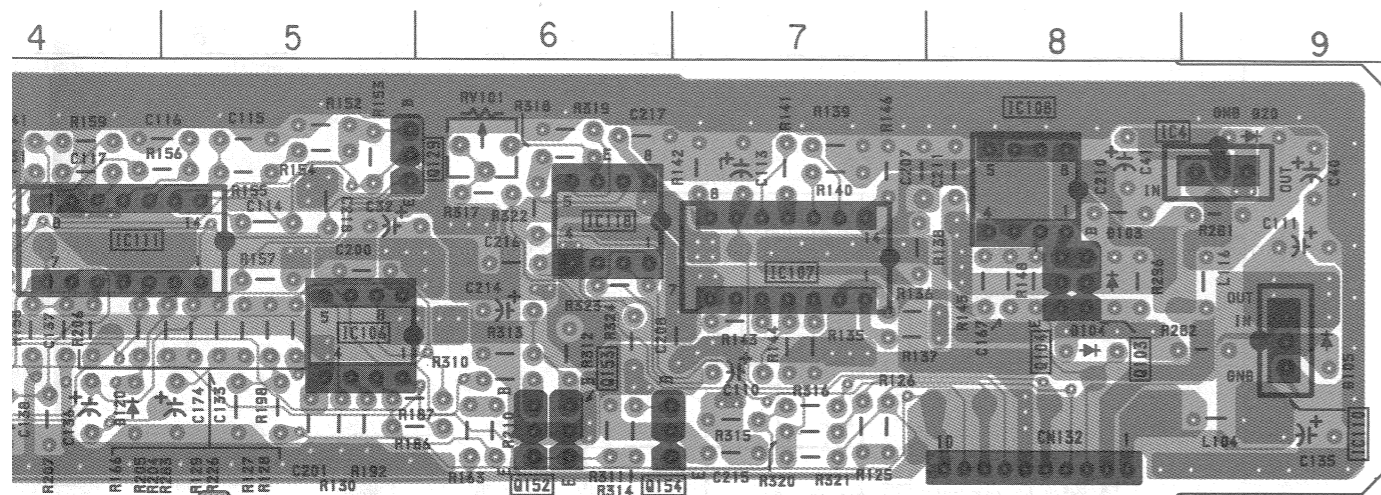

- EEB BOARD -

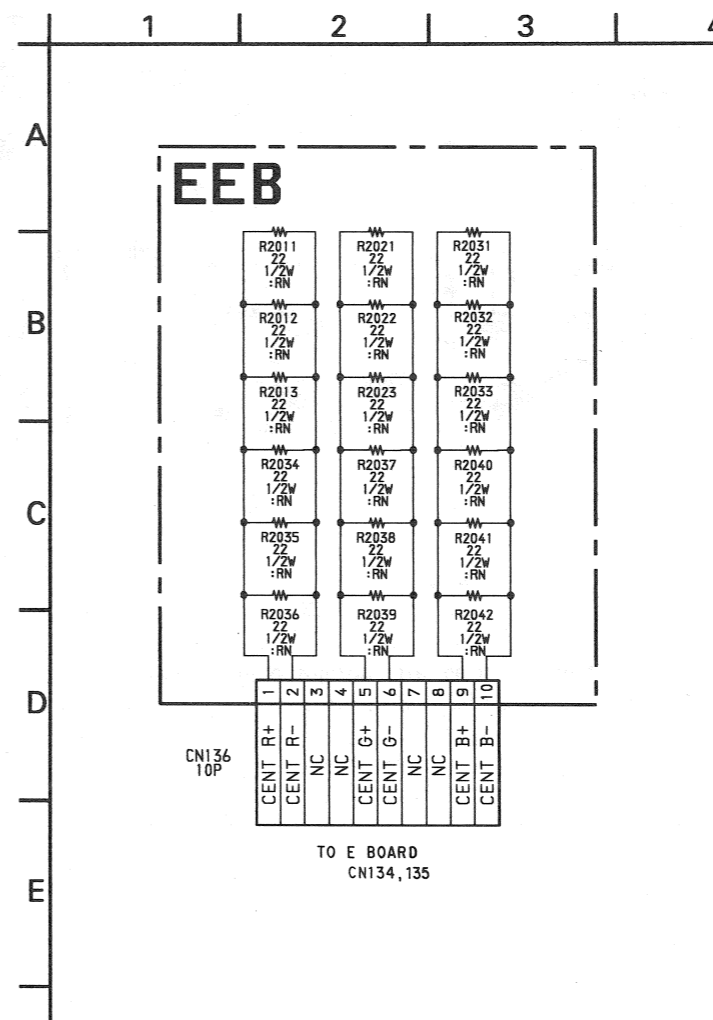
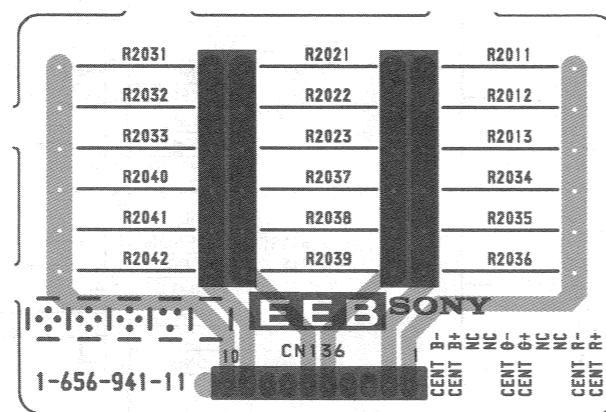

EEA BOARD

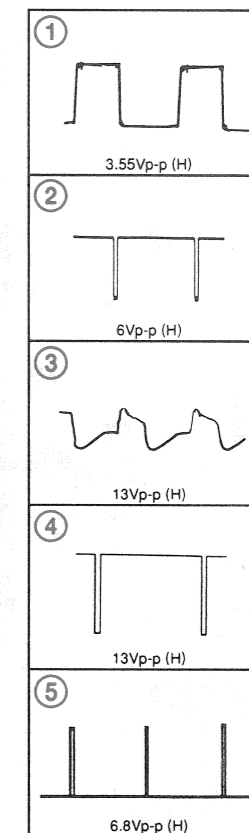

EEA BOARD

IC2004	+12V REG.
IC2101	H. PULSE GEN.
IC2103	F-V AMP
IC2104	F-V AMP
IC2105	F-V AMP
IC2106	F-V AMP
IC2107	MOD LEVEL CONT.
IC2108	PIN MOD PRE AMP
IC2110	-12V REG.
IC2111	PIN MOD REG. CONT.
IC2118	HV. MOD. AMP
Q2101	F-V SW
Q2103	PIN MOD PRE BUFF.
Q2104	PIN MOD PRE BUFF.
Q2129	POWER ON BIAS
Q2152	CENT CORRECT AMP
Q2153	CENT CORRECT AMP
Q2154	CENT CORRECT AMP
D2020	+12V REG. PROT.
D2103	PROT.
D2104	PROT.
D2105	-12V REG. PROT.
D2120	PROT.
D2131	PROT.
D2132	PROT.
D2143	CLAMP

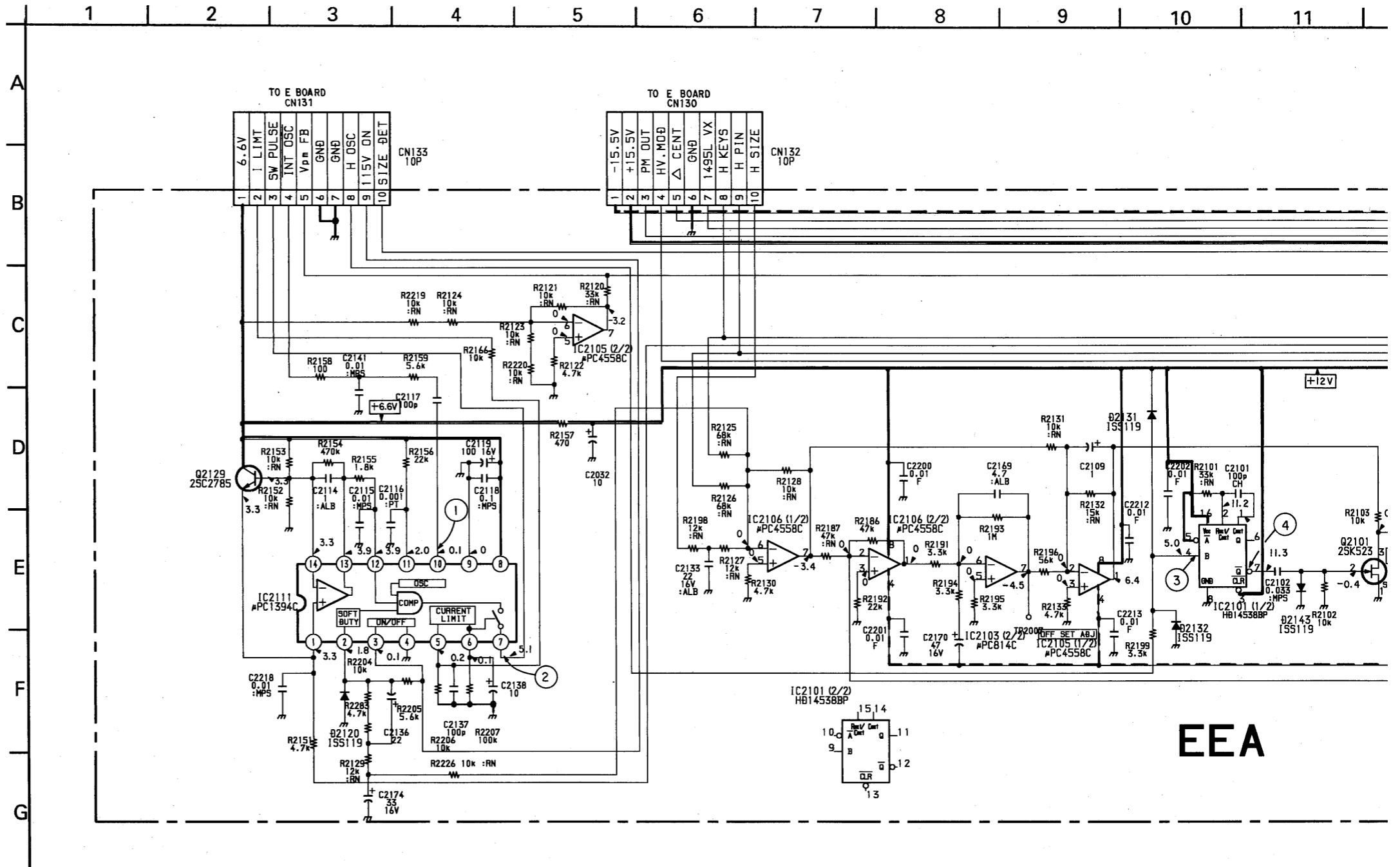

EEA

4 5 6 7 8 9 10 11 12 13 14 15 16 17 18 19

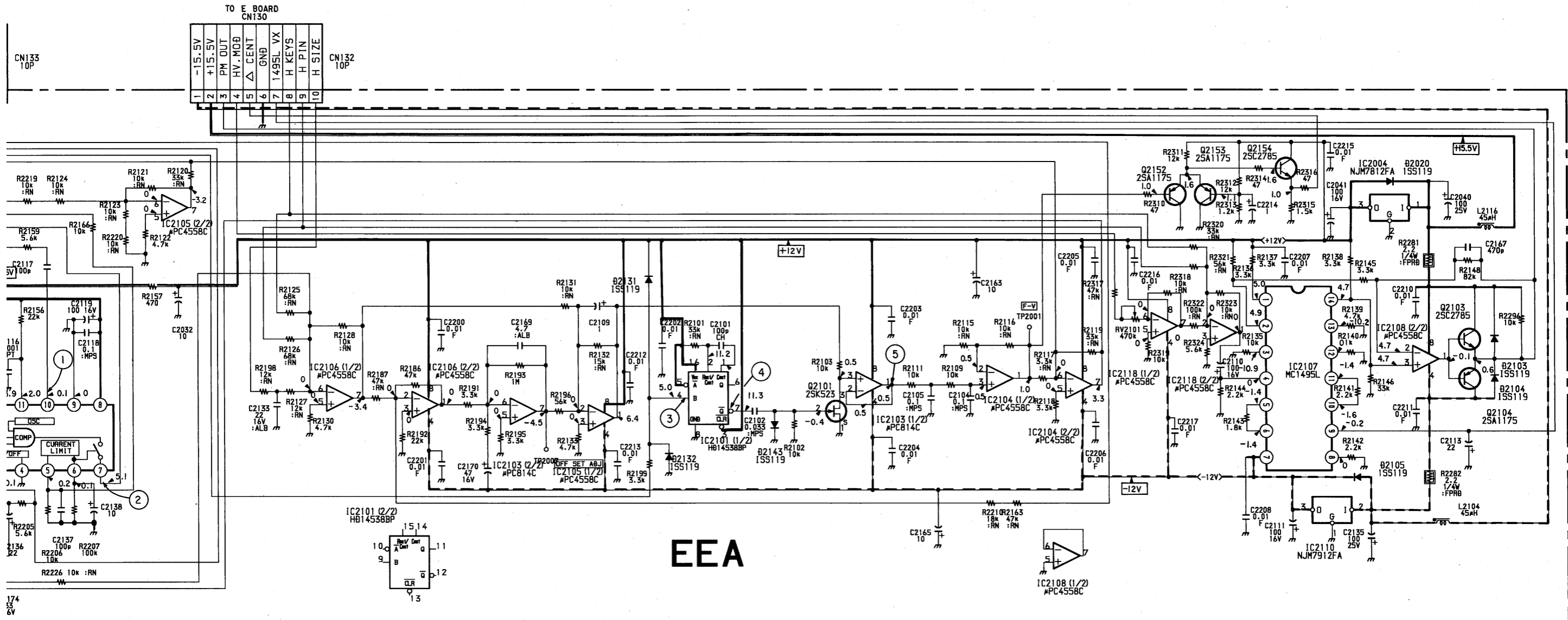

Schematic diagram

← EEA board