

# ***Multiscan Projector***

---

## **Installation Manual for Dealers**

**CAUTION**

**THIS INSTALLATION MANUAL IS FOR USE BY QUALIFIED PERSONNEL ONLY.**

**VPH-G70VRU  
VPH-G70VRM**

# Table of Contents

## **Installation**

<b>Installation Procedures</b> .....	<b>4</b>
<b>Installation Diagrams</b> .....	<b>5</b>
Necessary Clearance for Installation and Maintenance .....	5
Using the Handles to Carry the Projector .....	8
Floor Installation Using Front Projection Flat Screen .....	9
Ceiling Installation Using Front Projection Flat Screen .....	11
Floor Installation Using Rear Projection Flat Screen .....	13
Notes on Screen .....	15
<b>Modifying Parts</b> .....	<b>17</b>
Removing the Upper, Front and Rear Covers .....	17
Changing the Polarity .....	19
Adjusting the CRT Conversion Angle .....	21

## **Connections**

<b>Location and Function of Connectors</b> .....	<b>23</b>
<b>Switching the 75-ohm Terminate Connectors</b> .....	<b>25</b>
<b>Connecting Directly to the Projector</b> .....	<b>27</b>
<b>Using the Signal Interface Switcher</b> .....	<b>28</b>
<b>Connecting Multiple Projectors</b> .....	<b>31</b>
Using the Linked ABL Function .....	32

## **Before adjustment**

<b>Adjustment Procedures</b> .....	<b>34</b>
<b>For Remote Control</b> .....	<b>36</b>
Preparation .....	36
Keys on the Remote commander .....	39
<b>Using the MENU</b> .....	<b>42</b>
Basic Menu Operation .....	42
The INPUT SELECT Menu .....	43
The PIC CTRL (Picture Control) Menu .....	44
The INPUT SETTING Menu .....	46
The SET SETTING Menu .....	49
The INPUT INFO (Information) Menu .....	51
The SERVICE SETTING Menu .....	53
The SET INFO (information) Menu .....	54
The UNIFORMITY Menu .....	55
The ABL (Automatic Brightness Limiter) LINK Menu .....	56
The OPTION Menu .....	57
The INPUT MEM. (memory) OPTION Menu in Expert Mode .....	57

<b>Test Patterns .....</b>	<b>61</b>
Test Patterns .....	61
Test Patterns in Each Mode .....	63

## **Adjustments**

<b>Adjusting the Focus .....</b>	<b>64</b>
Focus Adjustment Procedure .....	64
Adjusting the Green Focus .....	66
Adjusting the Red and Blue Focus .....	72
<b>Adjusting the Registration .....</b>	<b>75</b>
Procedure .....	75
Preparation .....	76
Keys for Adjusting .....	77
Adjusting the Green Registration .....	78
Adjusting the Red Registration .....	87
Adjusting the Blue Registration .....	96
Saving the Standard Registration Data .....	97
<b>Fine Adjustment for Each Input Signal .....</b>	<b>98</b>
Adjusting the Video Input Signal .....	98
Adjusting the RGB Input Signal .....	102
Adjusting the White Balance .....	105
<b>Saving the Adjustment Data .....</b>	<b>107</b>
<b>Resetting the Data .....</b>	<b>109</b>
Resetting the data .....	110
<b>Protecting the Setting .....</b>	<b>111</b>
<b>Adjusting the Picture Quality .....</b>	<b>112</b>

## **Others**

<b>Changing the Initialization Period .....</b>	<b>113</b>
<b>About Error Codes .....</b>	<b>115</b>
<b>List of the Projection Distance by Angle of Optical Axis (for Flat Screen) .....</b>	<b>116</b>

## **Appendix**

<b>Installing the Curved Screen .....</b>	<b>124</b>
Installation Measurements for the Curved Screen .....	124
Setting the Switches on the D Board .....	126
<b>Projecting at More Than 15.2° Optical Axis Angle .....</b>	<b>128</b>
<b>Installing the VR System .....</b>	<b>129</b>
<b>Index .....</b>	<b>137</b>

# Installation

## Installation Procedures

By default, this projector is adjusted for 120-inch front projection on the floor/desk. If you install the projector in other conditions, you have to change some settings. Therefore, installation procedures depend on the screen size or type, and installation method.

- ① Verify the conditions of installation, such as angle of optical axis, projection distance, height of the projector and screen.  
↓
- ② Change the polarity according to the projection patterns. *(page 19)*  
↓
- ③ Install the projector and screen. *(page 9)*  
↓
- ④ Reset the registration data to factory setting. *(page 109)*  
↓
- ⑤ Adjust the CRT conversion angle. *(page 21)*  
↓
- ⑥ Adjust the lens focus and flapping of the lens. *(page 66)*  
↓
- ⑦ Adjust the magnetic focus and AQP (Axis Quadrupole)/DQP (Diagonal Quadrupole). *(page 70)*  
↓
- ⑧ Adjust the registrations. *(page 75)*  
↓
- ⑨ Connect other equipment. *(page 27)*  
↓
- ⑩ Adjust each input signal. *(pages 98 to 106)*
  - Fine adjustment for the magnetic focus and registrations. *(pages 98 and 102)*
  - Adjust the size or shift of the picture. *(pages 100 and 103)*
  - Adjust the blanking. *(pages 101 and 104)*

*For installing the curved screen and the VR system, see “Appendix” on pages 123 to 136.*

# Installation Diagrams

## Necessary Clearance for Installation and Maintenance

Make sure to provide enough room for maintenance service. Install the projector, making reference to the dimensions below.

There should be a space of at least 30 cm (1 3/16 inches) around the ventilation holes at the rear. Never block the holes with any material.

### Front

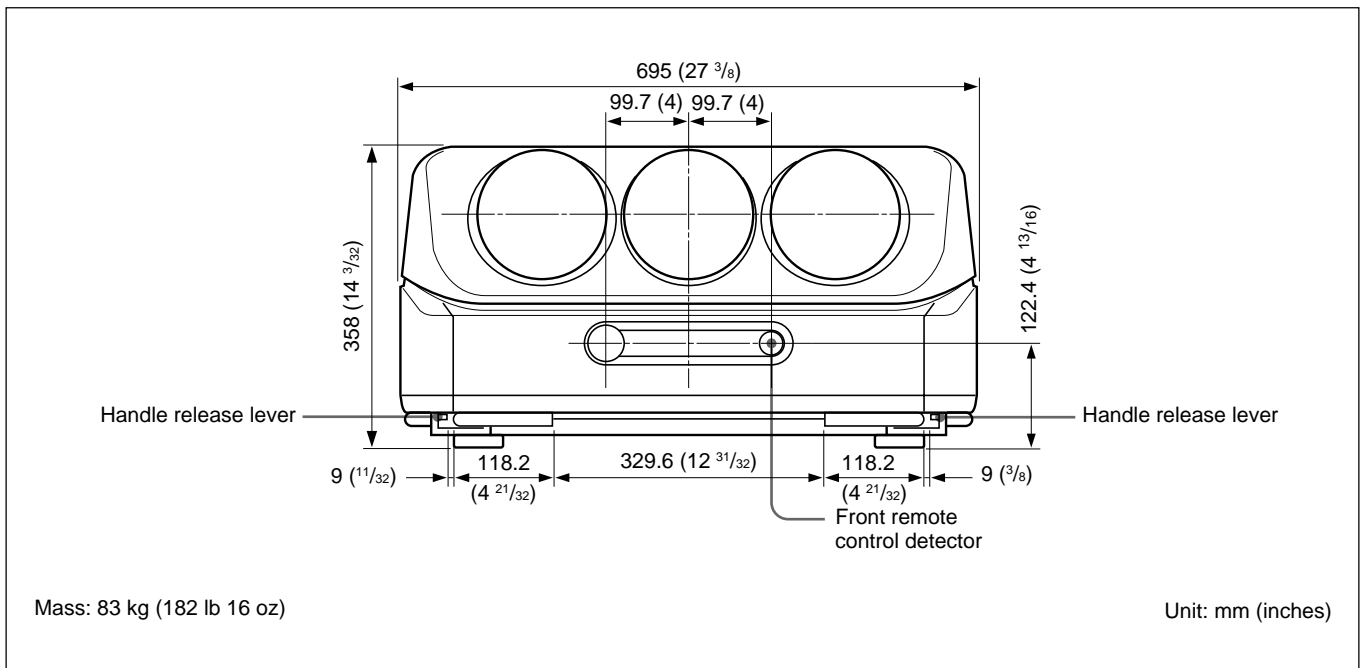

### Rear

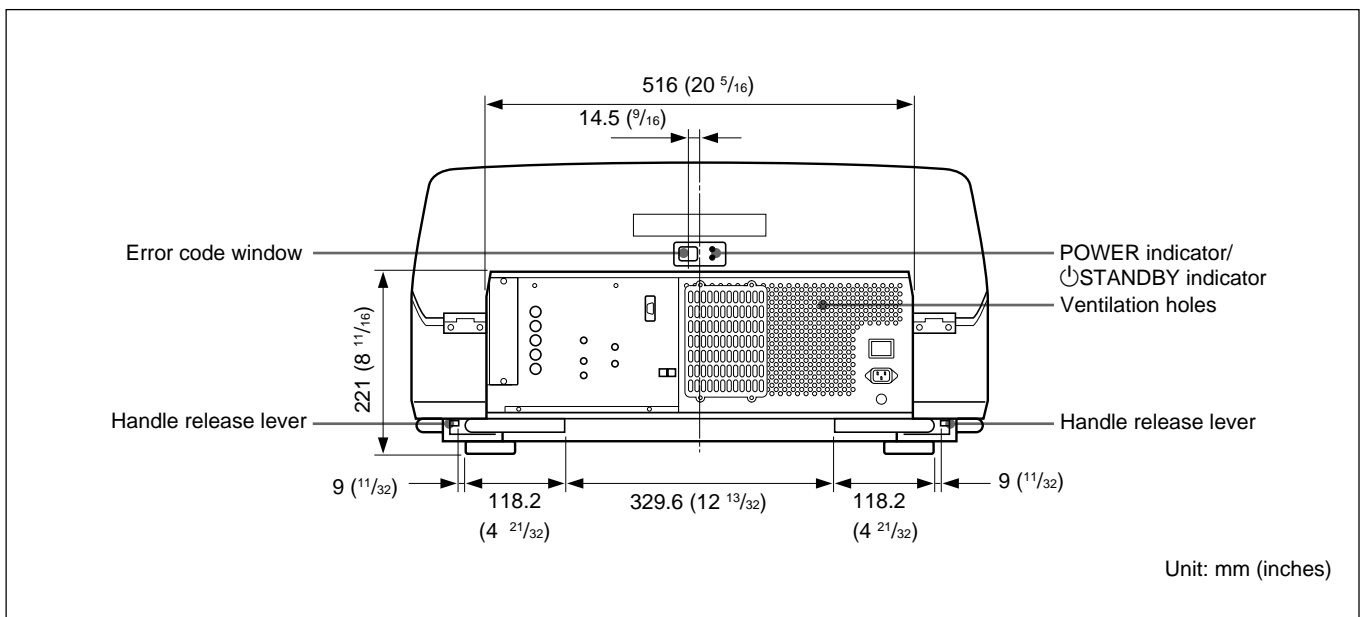

# Installation Diagrams

## Bottom

The standard hole for installation on the bottom surface is useful for reference when measuring for installation. There are seven holes on the bottom surface of the projector. For ceiling installation using the optional PSS-70 Projector Suspension Support, use five holes to attach the PSS-70. The other two holes are spare ones.

### Notes

- Use only the M8 meter screws of 10 mm ( $13/32$  inches) to 30 mm ( $1\ 3/16$  inches) long for the attachment holes for the PSS-70.
- When attaching the PSS-70, use the M8 meter screws of 20 mm ( $25/32$  inches) supplied with the PSS-70.

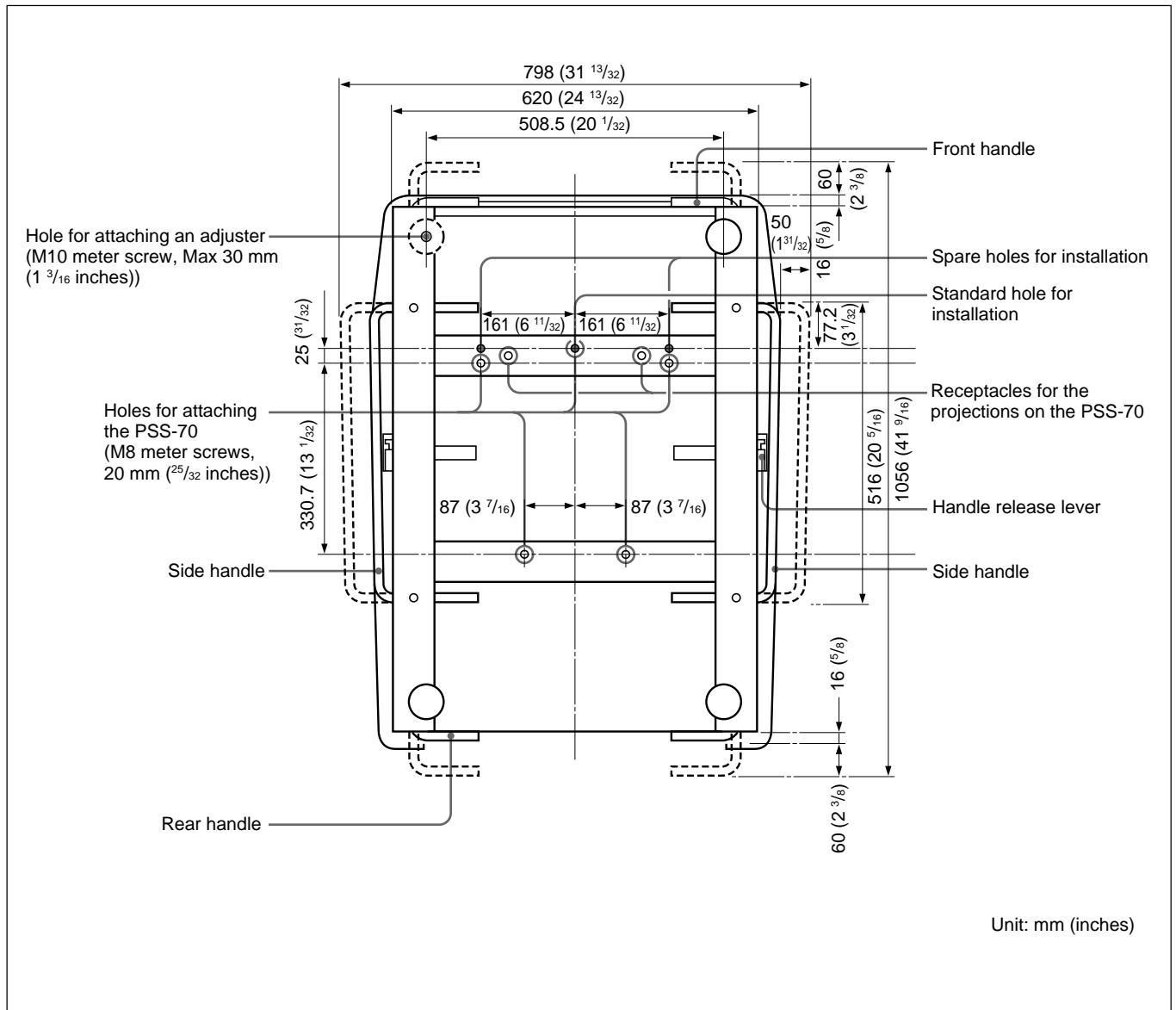

**Side**

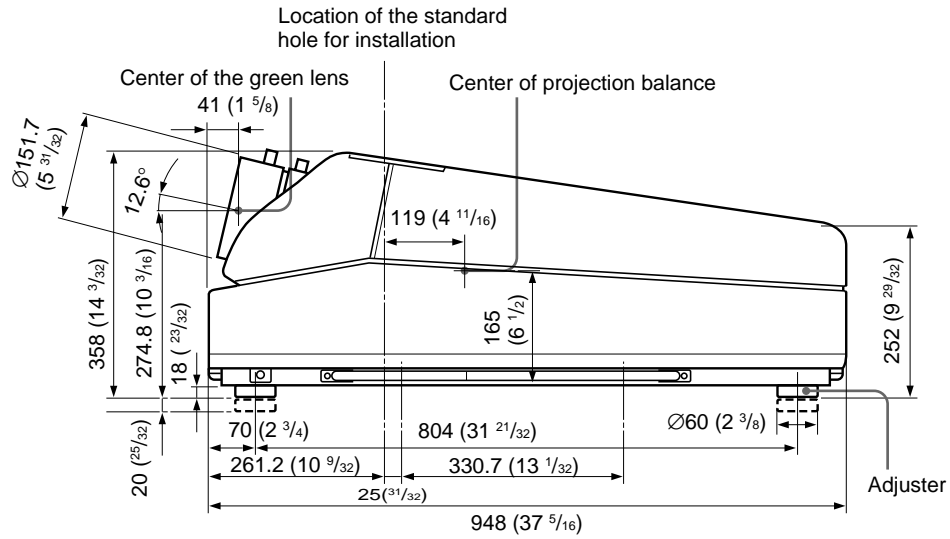

**With the covers open**

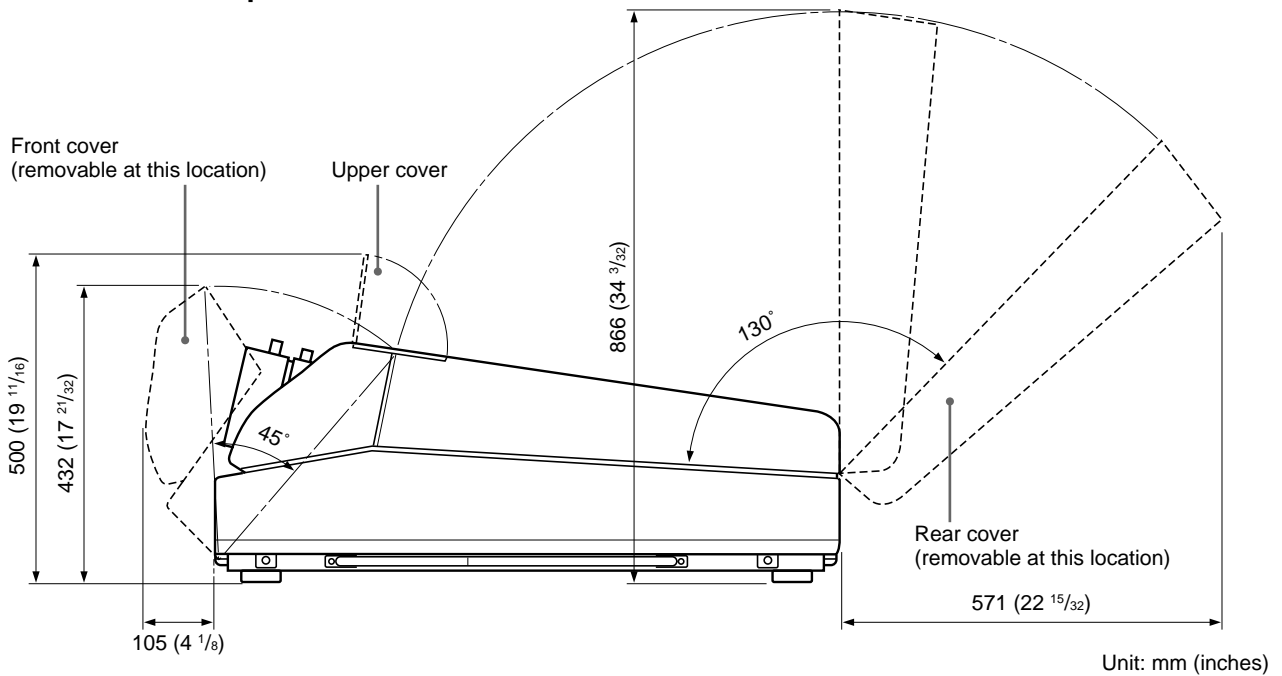

## Using the Handles to Carry the Projector

You can carry the projector by using the front, rear and side (right and left) handles.

### Using the handles

Pull out the front and rear handles or the side handles.

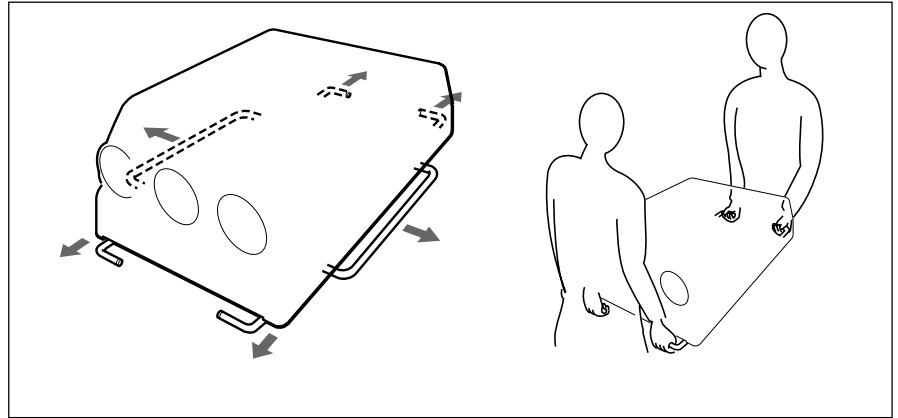

### Putting away the handles

Push the handle release lever under each handle. The handle is automatically retracted.

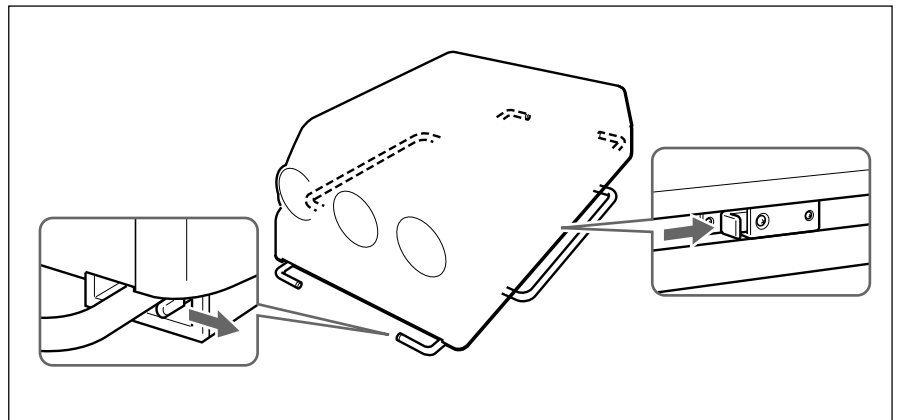



## Floor Installation Using Front Projection Flat Screen

Be sure that the projector is level to the floor.

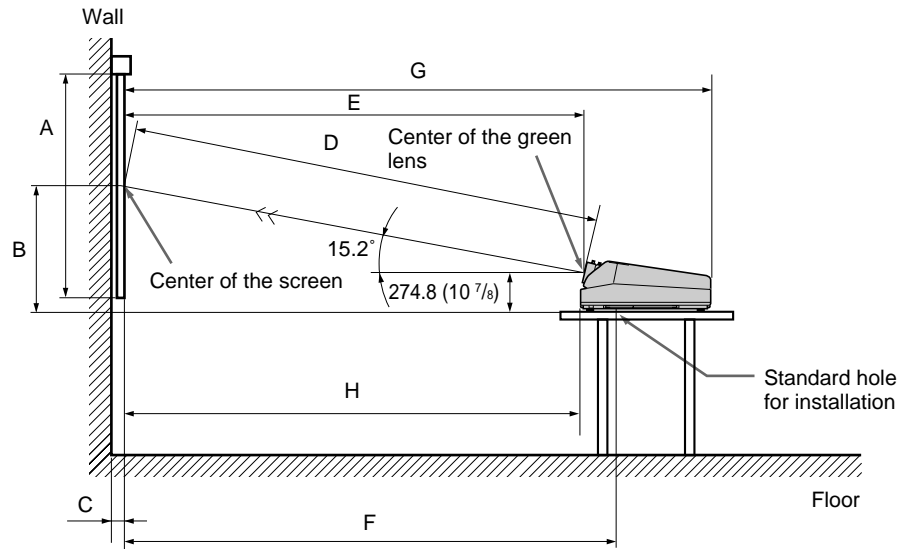

B: Difference in height between the projector's bottom surface and the center of the screen  
 E: Horizontal distance between the center of the screen and the center of the green lens  
 F: Horizontal distance between the center of the screen and the standard hole for installation

Tolerances

B:  $\pm 5\%$

Other measurements: 0% to +5%

The distances in gray are the factory preset settings. Unit:mm (inches)

Screen size (inches)	60	70	80	90	100	120	150	180	200	250	300
A (Vsize)	914 (36)	1067 (42 3/8)	1219 (48)	1372 (54 1/8)	1524 (60)	1829 (72 1/8)	2286 (90)	2743 (108)	3048 (120)	3810 (150)	4572 (180)
B (Hcent)	725 (28 5/8)	794 (31 3/8)	865 (34 1/8)	935 (36 7/8)	1005 (39 5/8)	1145 (45 1/8)	1356 (53 1/2)	1566 (61 3/4)	1707 (67 1/4)	2058 (81 1/8)	2410 (95)
C (Width)				28 <sup>a)</sup> (1 1/8)	32 <sup>b)</sup> (1 5/16)	32 <sup>c)</sup> (1 5/16)					
D (TD)	1727 (68)	1990 (78 3/8)	2256 (88 7/8)	2522 (99 3/8)	2787 (109 3/4)	3316 (130 5/8)	4117 (162 1/8)	4916 (193 5/8)	5446 (214 1/2)	6778 (266 7/8)	8117 (319 5/8)
E (Xlens)	1668 (65 3/4)	1921 (75 3/4)	2177 (85 3/4)	2434 (92 1/4)	2689 (105 7/8)	3200 (126)	3972 (156 1/2)	4743 (186 3/4)	5254 (206 7/8)	6539 (257 1/2)	7831 (308 3/8)
F (Lhole)	1888 (74 3/8)	2141 (84 3/8)	2397 (94 3/8)	2654 (104 1/2)	2910 (114 5/8)	3420 (134 3/4)	4193 (165 1/8)	4964 (195 1/2)	5475 (215 5/8)	6760 (266 1/4)	8051 (317)
G (Lmax)	2575 (101 1/2)	2828 (111 3/8)	3084 (121 1/2)	3341 (131 5/8)	3596 (141 5/8)	4107 (161 3/4)	4879 (192 1/8)	5650 (222 1/2)	6161 (242 5/8)	7446 (293 1/4)	8738 (344 1/8)
H (Lfront)	1627 (64 1/8)	1880 (74 1/8)	2136 (84 1/8)	2393 (94 1/4)	2648 (104 3/8)	3159 (124 3/8)	3931 (154 7/8)	4702 (185 1/8)	5213 (205 1/4)	6498 (255 7/8)	7790 (306 3/4)

a) Sony VPS-80FH and VPS-100FH

b) Sony VPS-100FM

c) Sony VPS-120FH and VPS-120FM

## When the Screen Size is not Mentioned in the Tables

You can calculate the installation measurements described below when you use the screen whose size is not mentioned in the tables on pages 9 and 11.

Check your installation conditions:

- Screen size to be used (S)
- Installation measurements at the end of the manual, EL and BL for larger screen size and ES and BS for smaller screen size

*See the tables on pages 116 to 122.*

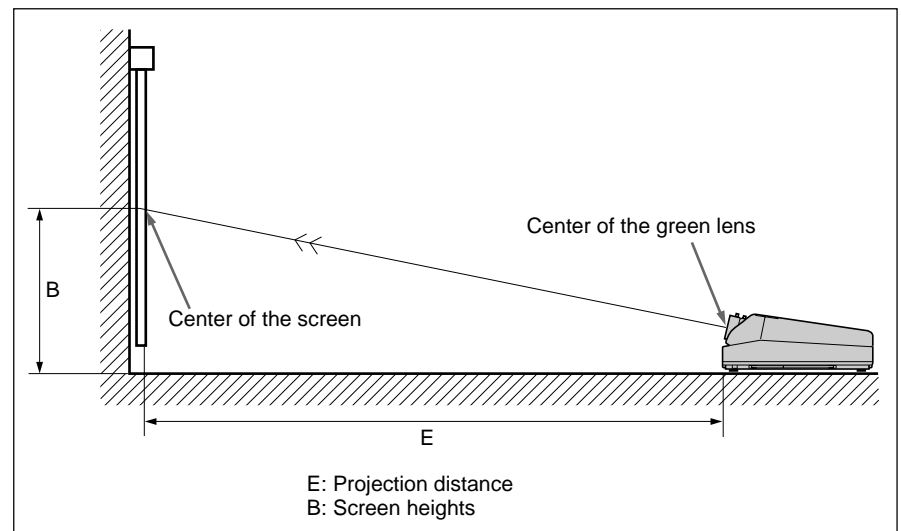

Now you can calculate the installation measurements as follows:

$$E \text{ (mm)} = ES + ((S - \text{smaller screen size}) \times (EL - ES) \times 0.1)$$

$$B \text{ (mm)} = BS + ((S - \text{smaller screen size}) \times (BL - BS) \times 0.1) + 275$$

### Example: when using 124-inch screen

According to the tables on page 115, the values E and B are as follows:

$$ES = 3200, BS = 870 \text{ (As the smaller screen size is 120 inch.)}$$

$$EL = 3457, BL = 940 \text{ (As the smaller screen size is 130 inch.)}$$

Therefore,

$$E \text{ (mm)} = 3200 + ((124 - 120) \times (3457 - 3200) \times 0.1) = 3303 \text{ (mm)}$$

$$B \text{ (mm)} = 870 + ((124 - 120) \times (940 - 870) \times 0.1) + 275 = 1173 \text{ (mm)}$$

## Ceiling Installation Using Front Projection Flat Screen

Use the PSS-70 Projector Suspension Support (not supplied).

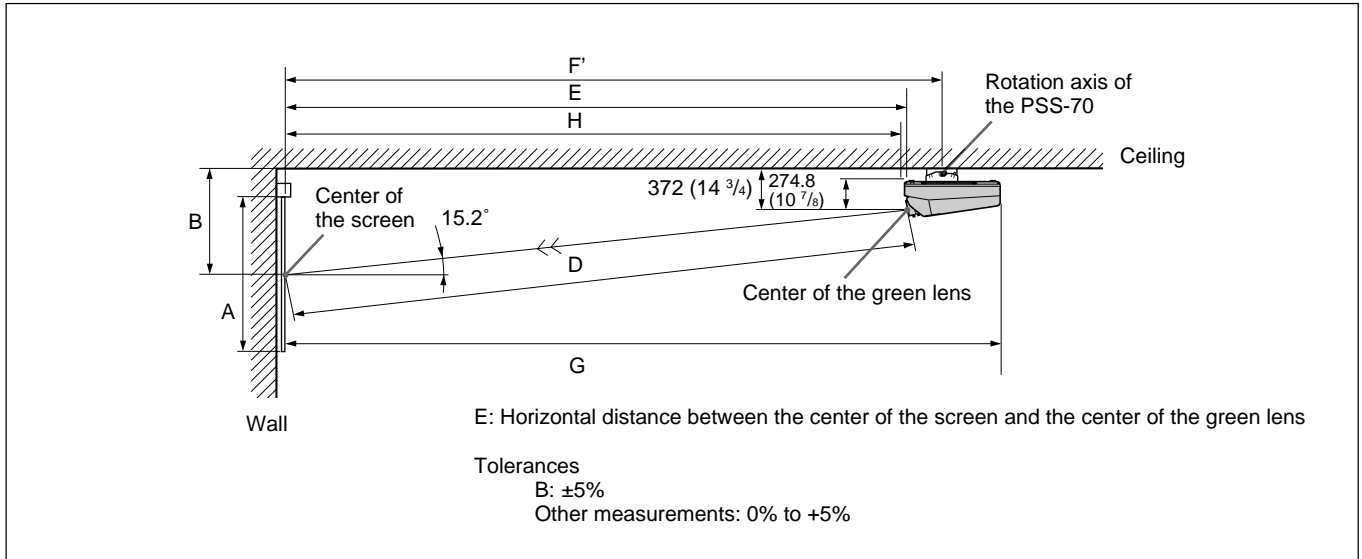

Unit:mm (inches)

Screen size (inches)	60	70	80	90	100	120	150	180	200	250	300
A (Vsize)	914 (36)	1067 (42 1/8)	1219 (48)	1372 (54 1/8)	1524 (60)	1829 (72 1/8)	2286 (90)	2743 (108)	3048 (120)	3810 (150)	4572 (180)
B (Hcent)	822 (32 3/8)	891 (35 1/8)	961 (37 7/8)	1032 (40 3/4)	1102 (43 1/2)	1241 (48 7/8)	1452 (57 1/4)	1663 (65 1/2)	1804 (71 1/8)	2155 (84 7/8)	2507 (98 3/4)
D (TD)	1727 (68)	1990 (78 3/8)	2256 (88 7/8)	2522 (99 3/8)	2787 (109 3/4)	3316 (130 5/8)	4117 (162 1/8)	4916 (193 5/8)	5446 (214 1/2)	6778 (266 7/8)	8117 (319 5/8)
E (Xlens)	1668 (65 3/4)	1921 (75 3/4)	2177 (85 3/4)	2434 (92 1/4)	2689 (105 7/8)	3200 (126 1/4)	3972 (156 1/2)	4743 (186 3/4)	5254 (206 7/8)	6539 (257 1/2)	7831 (308 3/8)
F' (Lpss)	1990 (78 3/8)	2243 (88 3/8)	2500 (98 1/2)	2756 (108 5/8)	3012 (118 5/8)	3523 (138 3/4)	4295 (169 1/8)	5066 (199 1/2)	5577 (219 5/8)	6862 (270 1/4)	8154 (321 1/8)
G (Lmax)	2575 (101 1/2)	2828 (111 3/8)	3084 (121 1/2)	3341 (131 5/8)	3596 (141 5/8)	4107 (161 3/4)	4879 (192 1/8)	5650 (222 1/2)	6161 (242 5/8)	7446 (293 1/4)	8738 (312 1/8)
H (Lfront)	1627 (64 1/8)	1880 (74 1/8)	2136 (84 1/8)	2393 (94 1/4)	2648 (104 3/8)	3159 (124 3/8)	3931 (154 7/8)	4702 (185 1/8)	5213 (205 1/4)	6498 (255 7/8)	7790 (304 3/4)

### Necessary parts modifications

Changing the polarity used for “Ceiling installation, front projection”

For details, see “Changing the Polarity” on page 19.

## Attaching the PSS-70 Projector Suspension Support

Attach the projector mounting bracket to the bottom surface of the projector.

Use five each of the M8×20 bolts, M8 washers and spring washers, all of which are supplied with the PSS-70.

- 1** Align the two projections on the projector mounting bracket with the receptacles on the bottom surface of the projector.
- 2** Fasten the five bolts and washers to fix the mounting bracket to the five holes for attaching the PSS-70 on the bottom surface of the projector.

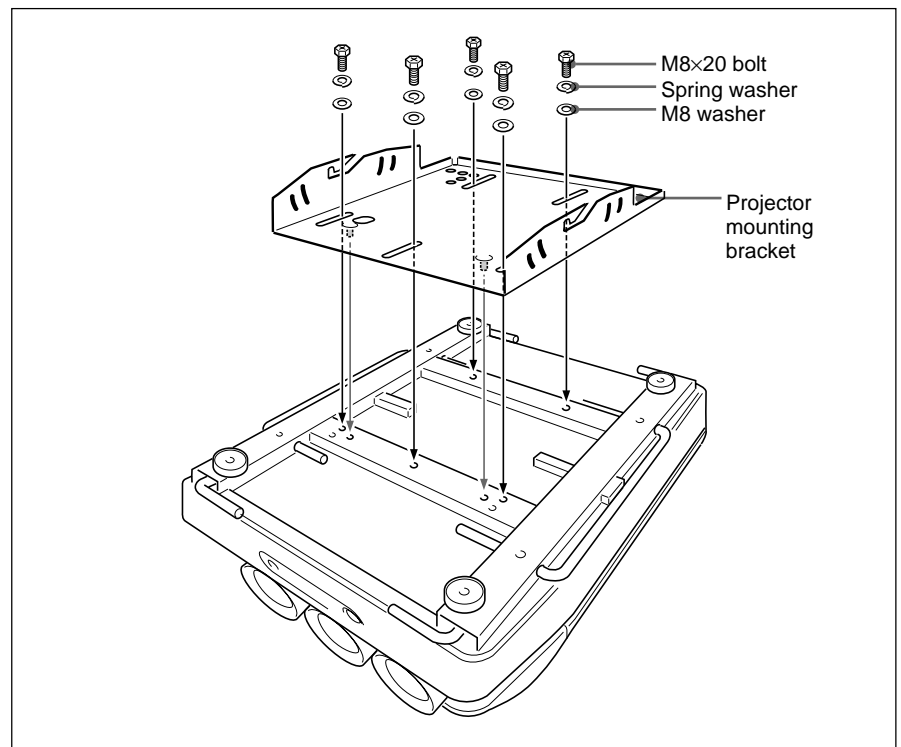

*For attaching the PSS-70 to the ceiling, refer to the Installation Manual of the PSS-70 Projector Suspension Support.*

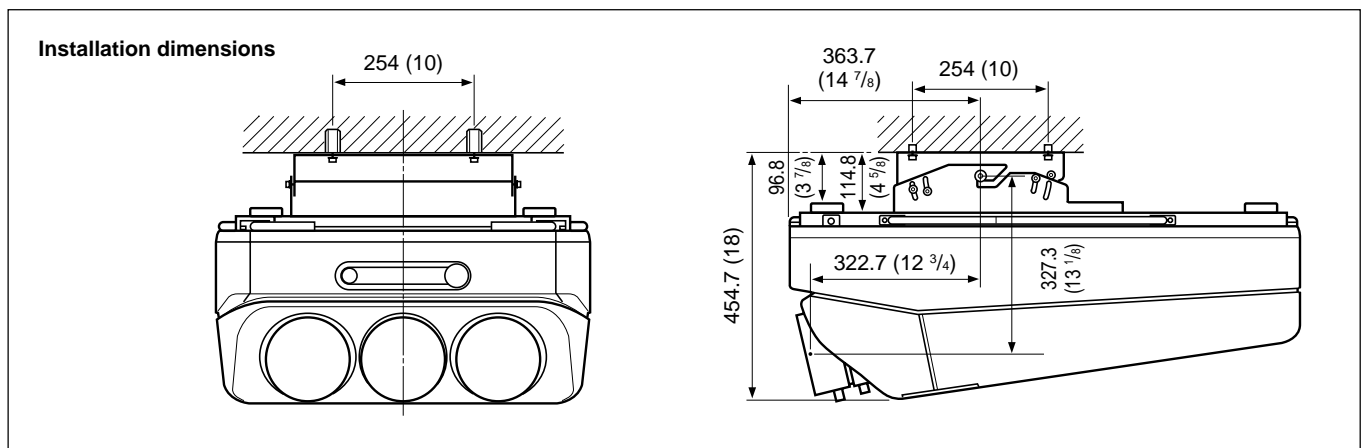

## Floor Installation Using Rear Projection Flat Screen

### What is the optical axis angle?

The optical axis angle is the angle between the horizontal level line and the straight line from the center of the projector's green lens to the center of the screen. When using a rear projection screen, you can get the brightest picture when the center of the screen is aligned with a straight line extension of the center of the green lens.

Therefore, the most suitable optical axis angle varies depending on the height of the screen and your line of sight.

### When the optical axis angle is 2°

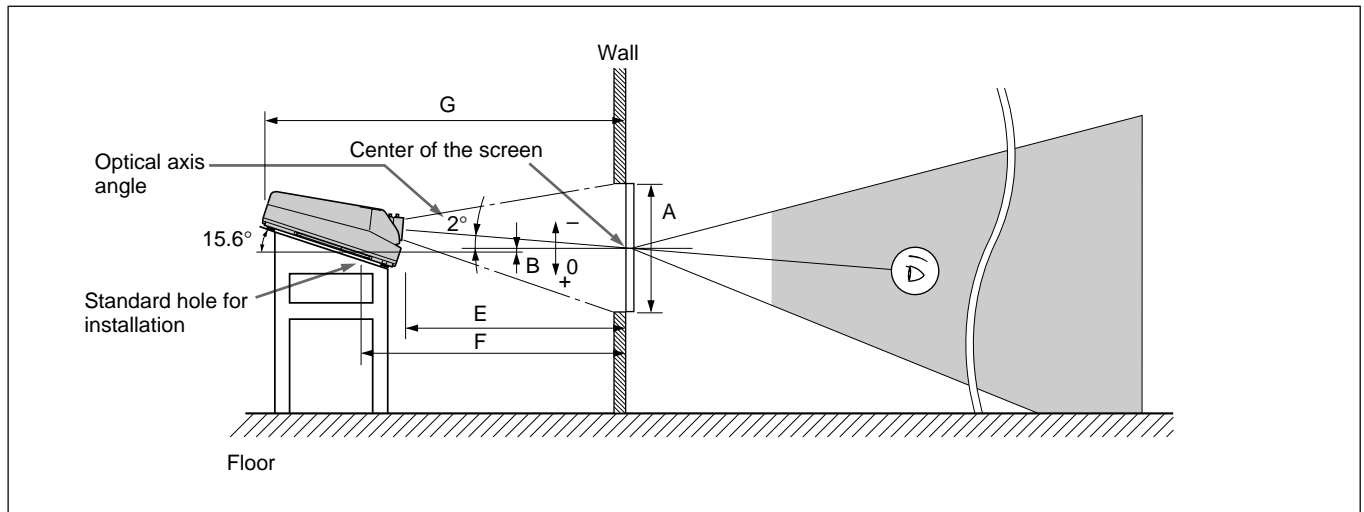

	Unit: mm (inches)										
Screen size (inches)	60	70	80	90	100	120	150	180	200	250	300
A (Vsize)	914 (36)	1067 (42 1/8)	1219 (48)	1372 (54 1/8)	1524 (60)	1829 (72 1/8)	2286 (90)	2743 (108)	3048 (120)	3810 (150)	4572 (180)
B (Hcent)	127 (5)	118 (4 3/4)	108 (4 3/8)	99 (4)	89 (3 5/8)	70 (2 7/8)	42 (1 11/16)	14 (9/16)	-5 (-7/32)	-52 (-2 1/8)	-100 (-4)
E (Xlens)	1757 (69 1/4)	2024 (79 3/4)	2294 (90 3/8)	2564 (101)	2834 (111 5/8)	3371 (132 3/4)	4185 (164 7/8)	4997 (196 3/4)	5536 (218)	6889 (271 1/4)	8250 (324 7/8)
F (Lhole)	2038 (80 1/4)	2305 (90 3/4)	2575 (101 1/2)	2845 (112 1/8)	3115 (122 3/4)	3652 (143 7/8)	4466 (175 7/8)	5279 (207 7/8)	5817 (229 1/8)	7171 (282 3/8)	8531 (335 7/8)
G (Lmax)	2700 (106 3/8)	2966 (116 7/8)	3236 (127 1/2)	3507 (138 1/8)	3776 (148 3/4)	4314 (169 7/8)	5128 (202)	5940 (233 7/8)	6478 (255 1/8)	7832 (308 3/8)	9193 (362)

### Necessary parts modifications

Changing the polarity used for "Floor installation, rear projection"  
 For details, see "Changing the Polarity" on page 19.

## Variable Range of the Optical Axis Angle in Rear Projection

You can change the optical axis angle within the following ranges by adjusting flapping of the lens.

For adjusting flapping of the lens, see “Adjusting flapping of the green lens” on page 68.

### On floor installation

You can install the projector within an angle of optical axis  $-15.2^\circ$  to  $+2^\circ$ .

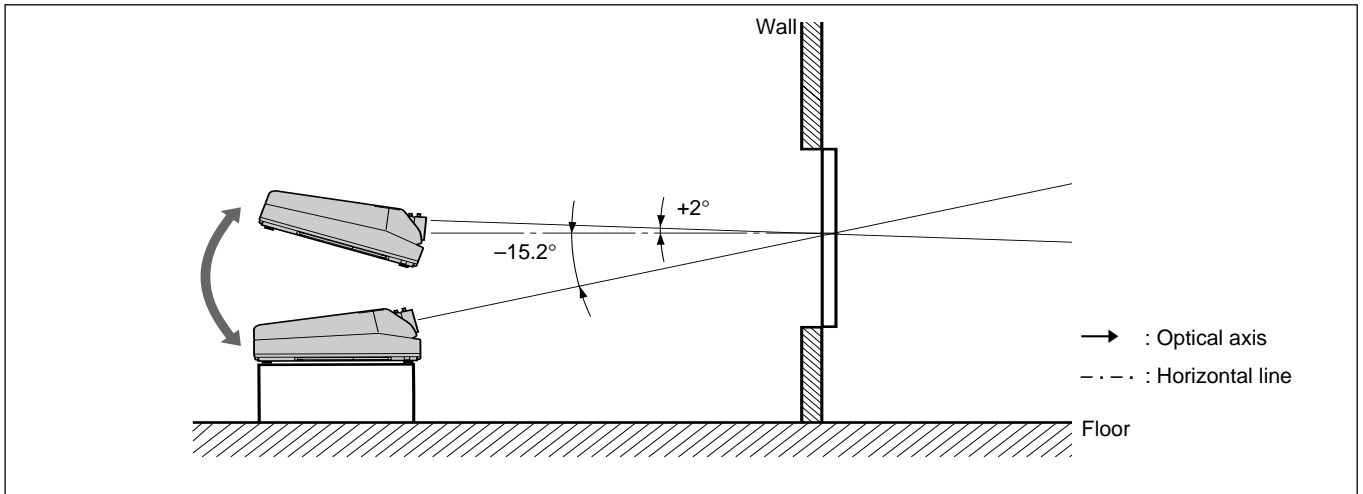

### On ceiling installation

You can install the projector within an angle of optical axis  $+3^\circ$  to  $+15.2^\circ$ .

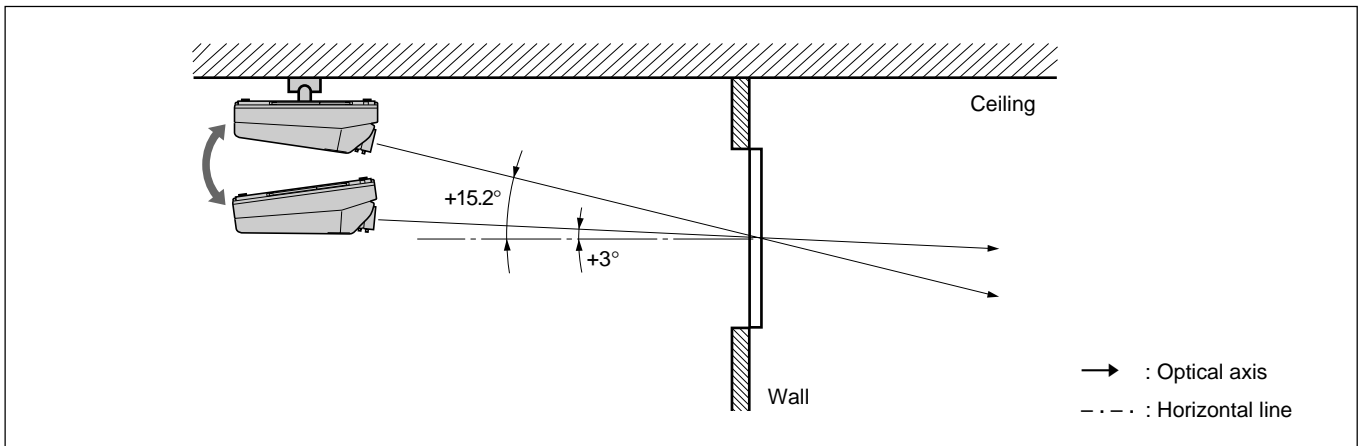

## Notes on Screen

### Screen size

The screen size is the diagonal length of the screen in inches, while the aspect ratio of the screen is 4:3. The ratio of the screen height, width, and diagonal is 3:4:5.

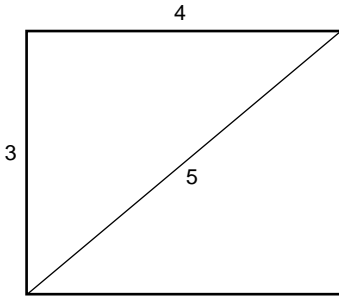

If you use a screen with 4:3 aspect ratio whose size is not given in the table below, you can calculate the screen height and width from the screen size (inches) as follows.

Calculate at the conversion rate of 25.4 mm to the inch.

$$\text{Height (mm)} = \text{Screen size} \times 25.4 \times \frac{3}{5}$$

$$\text{Width (mm)} = \text{Screen size} \times 25.4 \times \frac{4}{5}$$

### Screen size and dimensions

Screen size (inches) (Diagonal)	Height (mm)	Width (mm)
60	914	1219
70	1067	1422
80	1219	1626
90	1372	1829
100	1524	2032
120	1829	2438
150	2286	3048
180	2743	3658
200	3048	4064
250	3810	5080
300	4572	6096

### Screens with an aspect ratio other than 4:3

#### When the height is greater

Calculate the screen size with 4:3 aspect ratio from the screen height as shown below. Install the projector and screen in accordance with the screen size obtained.

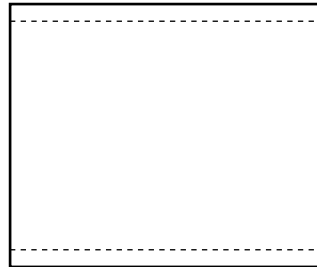

--- : Screen whose aspect ratio is 4:3

$$\text{Screen size (inch)} = (\text{height (mm)} \times \frac{5}{3}) \times \frac{1}{25.4}$$

**Example:** When the screen height is 1500 mm  
 $(1500 \text{ (mm)} \times \frac{5}{3}) \times \frac{1}{25.4} = \text{Approx. 98 inches}$

#### When the width is greater

Calculate the screen size with 4:3 aspect ratio from the screen width as shown below. Install the projector and screen in accordance with the screen size obtained.

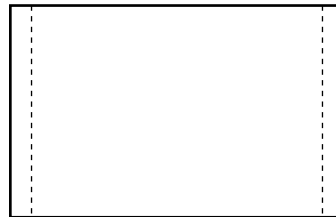

---: Screen whose aspect ratio is 4:3

$$\text{Screen size (inch)} = (\text{width (mm)} \times \frac{5}{4}) \times \frac{1}{25.4}$$

**Example:** When the screen width is 2000 mm  
 $(2000 \text{ (mm)} \times \frac{5}{4}) \times \frac{1}{25.4} = \text{Approx. 98 inches}$

# Installation Diagrams

## Types of screen

### Front projection screen for floor installation

The bead screen is recommended. A screen of this type reflects the brightest light.

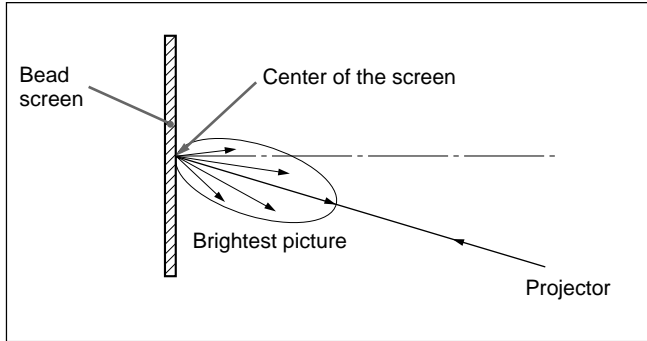

### Front projection screen for ceiling installation

The silver screen is recommended. You can get a picture that is two to four times brighter than that of the white screens.

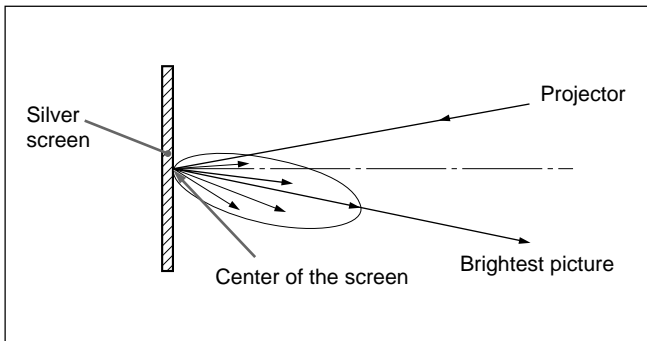

### Rear projection screen

A screen manufactured using two sheets, the fresnel and lenticular, is recommended for a bright and clear full-screen picture projection.

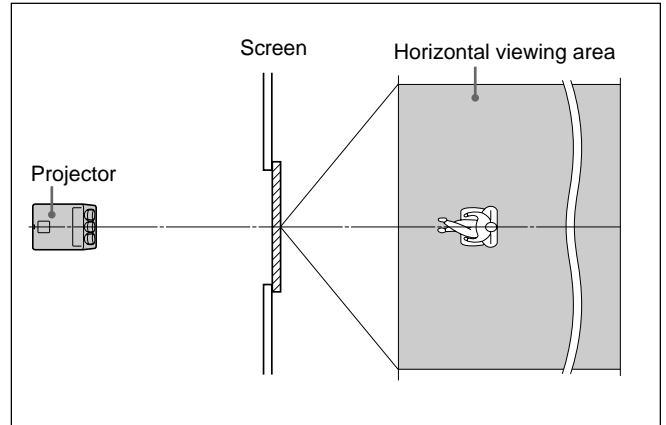

### White screen

When viewers watch the projected picture in a wide area, you can obtain a picture that appears equally bright from all parts of the room using the white screen for both floor and ceiling installations. Note that you will not be able to get a clear picture in this case unless the room is dark.

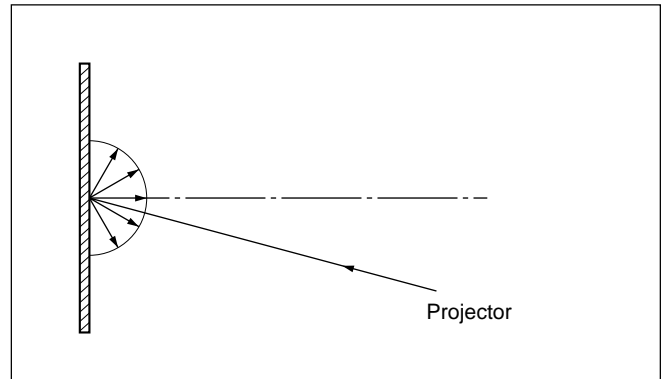



## Removing the Upper, Front and Rear Covers

Most modifications can be performed only by opening the upper cover.

### Opening the upper cover

- 1 Turn off the main power of the projector.
- 2 Unlock the two screws on the projector by using a screwdriver or a coin edge, and then open the upper cover.

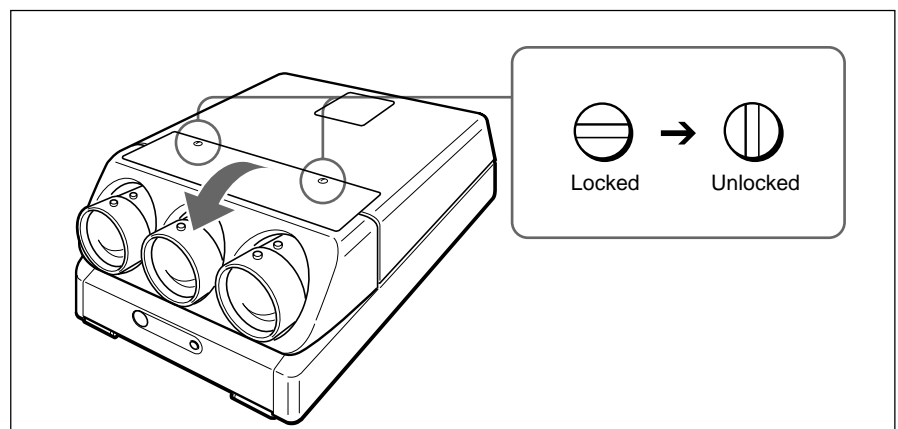

### To remove the supplied tool

The tool is located on the back of the upper cover.

Loosen the screw by using a screwdriver or a coin edge and remove the tool.

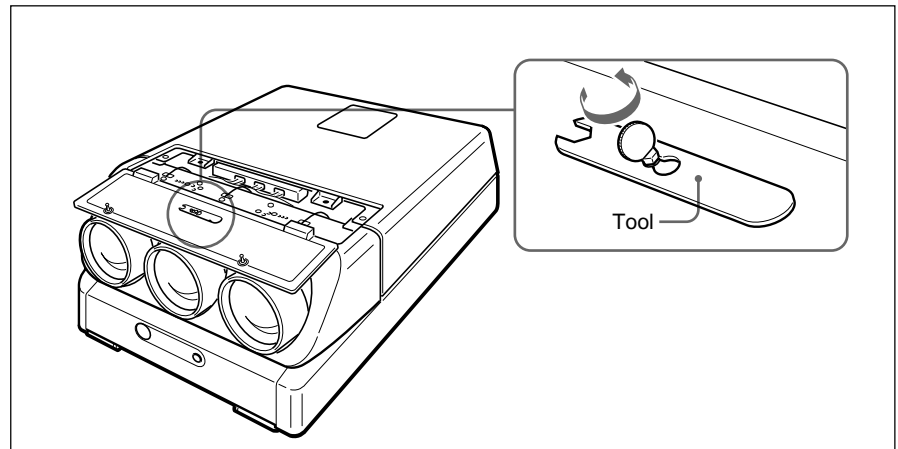

## Removing the front and rear covers

Remove the front and rear covers with the upper cover open.

- 1** Unlock the two screws by using the supplied tool to remove the rear cover.

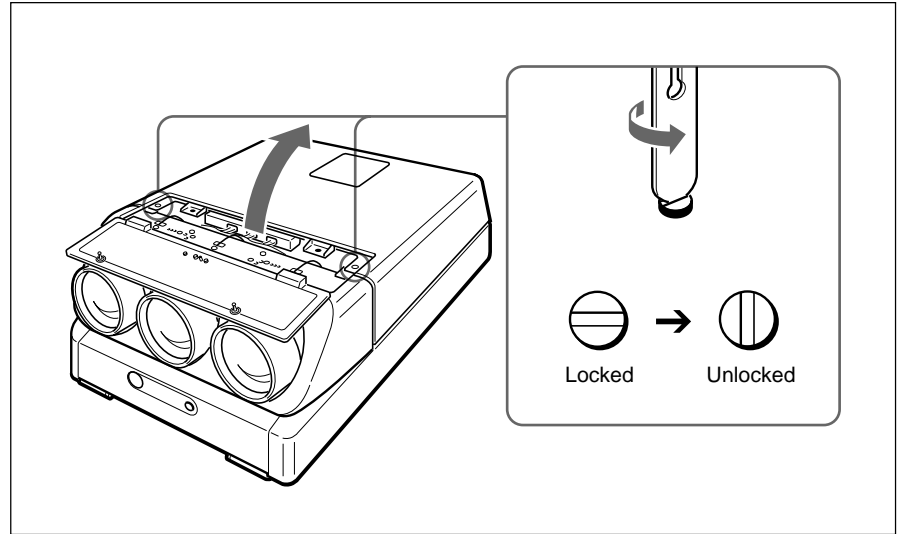

- 2** While pushing the catches inside the front cover outwards, slide to remove the front cover.

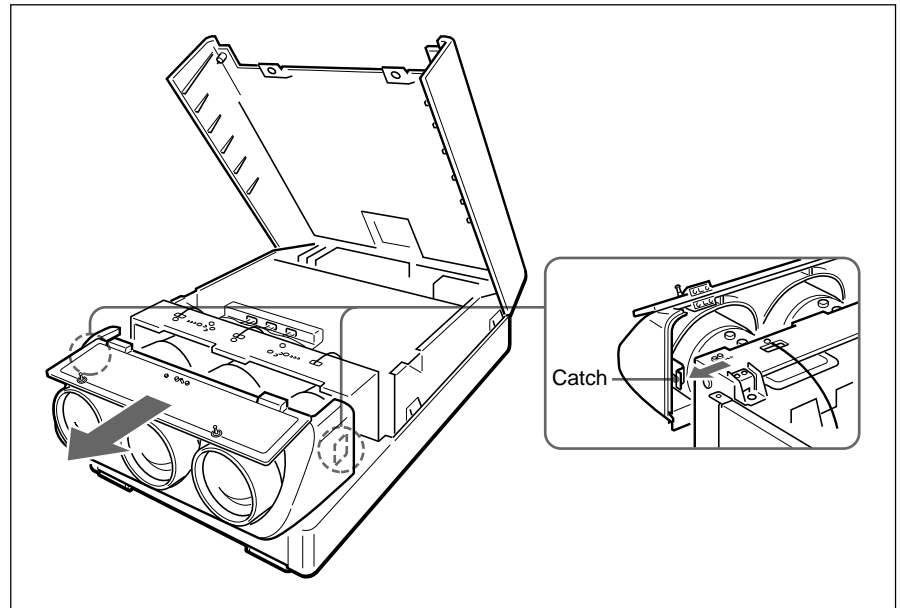

## Changing the Polarity

The polarity of the projector is adjusted to use the projector for front projection on the floor.

When the projector is installed on the ceiling or used in rear projection, it is necessary to change the settings of the polarity switch and the polarity connectors.

### How to change the polarity

- 1** Turn off the power of the projector.
- 2** Open the upper cover.  
*For details, see “Opening the upper cover” on page 17.*
- 3** Press to open the connector cover.
- 4** Check the polarity switch position and the connecting position of the polarity connectors.  
*For the installation methods of the projector and the settings of the switch and the connectors, see the diagram on the next page.*

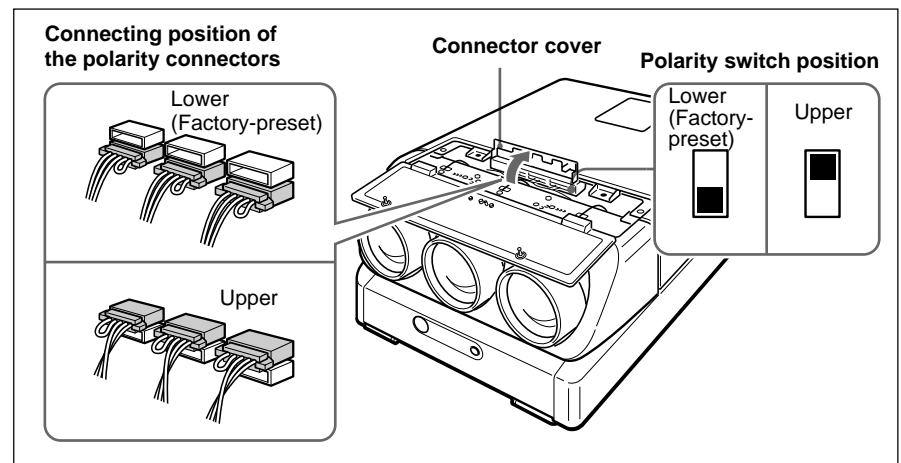

- 5** Change the switch position and/or the connecting position of the connectors, if necessary.  
**Polarity switch:** Set to the upper or lower position.  
**Polarity connectors:** Disconnect the three connectors, then turn them over (180°) and reinsert into the upper or lower receptacles.

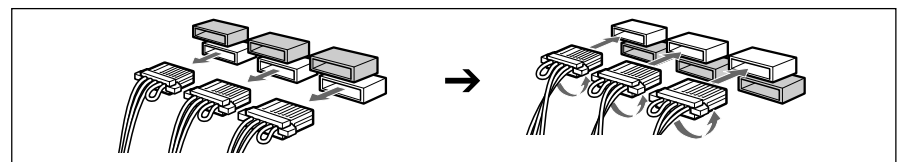

- 6** Make sure to insert the connectors correctly and to set the switch to the correct position, then restore the connector cover and the upper cover.

#### Note

If the connector cover does not shut firmly, the power of the projector is not turned on.

## Installation methods and settings of the polarity switch and the polarity connectors

Installation methods	Position of the switch	Connecting position of the connectors	On-screen display by default (See below.)
Front projection, floor	Lower	Lower	Correct
Front projection, ceiling	Upper	Upper	<b>C</b>
Rear projection, floor	Lower	Upper	<b>A</b>
Rear projection, ceiling	Upper	Lower	<b>B</b>
Others	Display letters on the screen so that you can determine which changes to make. <i>For on-screen display and necessary changes, see below.</i>		

### Note

When installing the projector, make sure to leave space of more than 30 cm (12 inches) between the wall or floor and the ventilation holes of the projector.

## Polarity and on-screen display

When the projector is installed on the ceiling or used in rear projection without changing the polarity, one of the following on-screen displays appears. In this case, you have to change the polarity corresponding to the installation methods.

### **A** The letters are backward.

Change the connecting position of the polarity connectors.

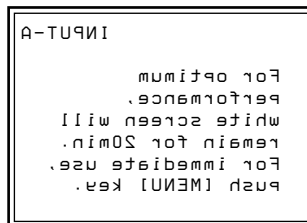

### **B** The letters are upside down.

Change the polarity switch position.

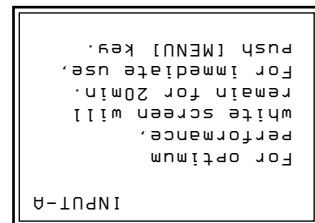

### **C** The letters are upside down and backward.

Change the polarity switch position and the connecting position of the polarity connectors.

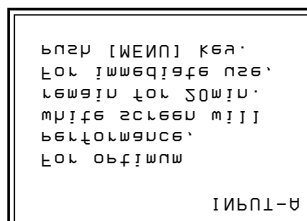

## Adjusting the CRT Conversion Angle

Adjust the CRT conversion angle so that the three CRT images converge exactly.

- 1** Open the upper cover.  
*For details, see "Opening the upper cover" on page 17.*
- 2** Turn on the power of the projector.
- 3** Set the remote control to the service adjustment mode.  
*For details, see "Preparation" on page 36.*
- 4** Reset the green, red and blue centering.  
*For details, see "Resetting the Data" on page 109.*
- 5** Make sure that the on-screen display is shown as follows:
  - The center of the green hatch pattern aligns with the horizontal center of the screen.
  - The center of the red and blue hatch patterns align at even intervals from the green hatch pattern.

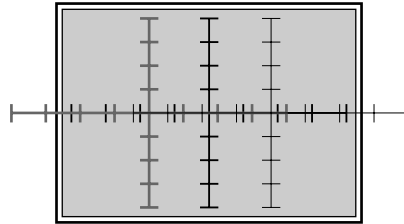

If the center of the green hatch pattern does not align with the center of the screen, re-install the projector correctly.

- 6** Loosen the two red CRT fixing screws (black) by using the Philips screwdriver. Make sure not to remove the screws.

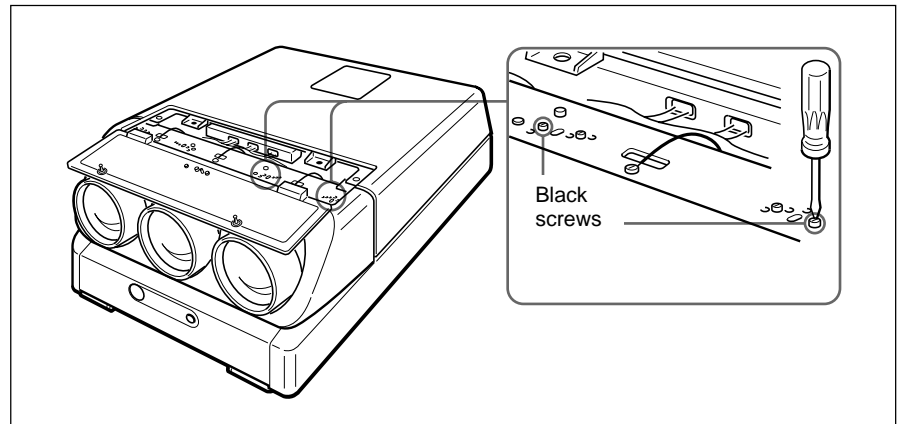

(continued)

- 7 Insert the two adjustment screws (gold) into the appropriate adjustment holes corresponding to the screen size.

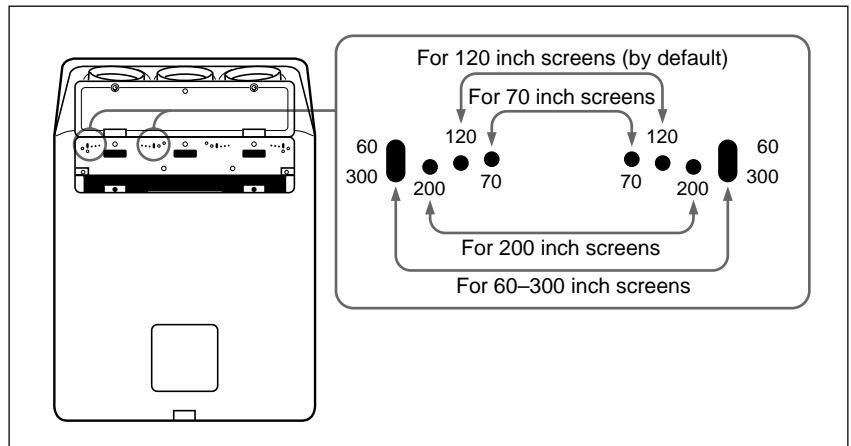

By default, the two adjustment screws are fixed to the two adjustment holes for 120 inch screens.

For 70 and 200 inch screens, remove the adjustment screws and insert them into the corresponding holes.

For screens other than 70, 120 and 200 inch screens, insert the screws into the elliptic holes for 60–300 inch screens.

- 8 For screens other than 70, 120 and 200 inch screens, move the red CRT right and left so that the vertical line of the red cross hatch pattern converges with the green pattern, then tighten the two adjustment screws (gold).
- 9 Tighten the two red CRT fixing screws (black).
- 10 Repeat steps 6 to 9 to loosen the two blue CRT fixing screws (black), adjust the blue CRT conversion angle and tighten the two adjustment screws (gold).

# Connections

## Location and Function of Connectors

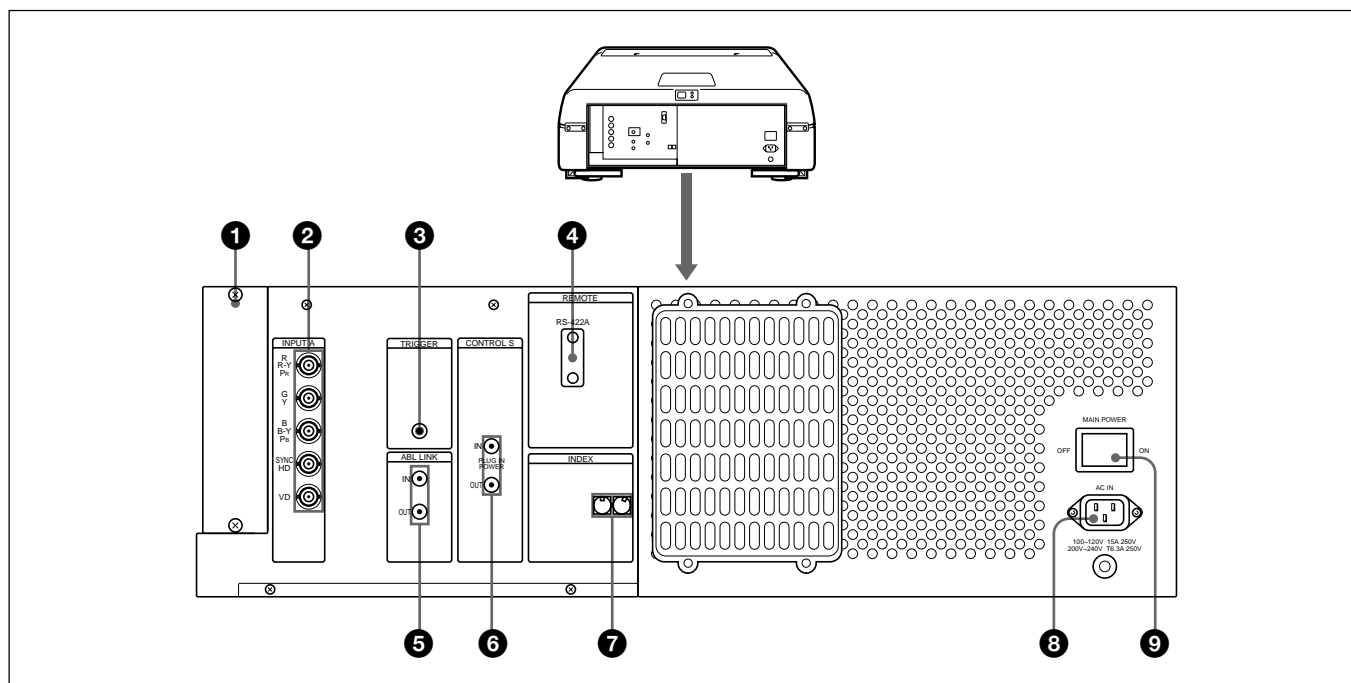

### ❶ Signal interface board attachment part (INPUT B)

Attach an optional signal interface board IFB-40, IFB-1000, etc.

### ❷ INPUT A connectors (BNC type)

R/R-Y/P<sub>R</sub>, G/Y, B/B-Y/P<sub>B</sub>, SYNC/HD, VD

**connectors:** Connect to the outputs of a computer or a video camera. According to the connected equipment, the RGB (R, G, B), component (R-Y, G, B-Y) or HDTV (P<sub>R</sub>, Y, P<sub>B</sub>) signal is selected.

### ❸ TRIGGER connector (minijack)

When the projector is turned on, 12 V is output and when it is turned off, 0 V is output. However, the connector is not used as the power source since the power is not output.

### ❹ RS-422A REMOTE connector (D-sub 9-pin)

Used to expand the system connections using the RS-422A interface.

Before using the connector, loosen the two screws to remove the cap.

## Location and Function of Connectors

---

### ⑤ ABL (Automatic Brightness Limiter) LINK IN/OUT jacks (minijack)

When connecting multiple projectors, connects the ABL LINK OUT jack to the ABL LINK IN jack on another projector. You can synchronize the brightness limiting point among the projectors, allowing to make the whole screen brightness uniform.

### ⑥ CONTROL S jacks IN/PLUG IN POWER (5 V) jack (stereo

**minijack):** Connects to the CONTROL S OUT jack of other Sony equipment. Also connects to the CONTROL S OUT jack of the supplied remote commander with the supplied remote control cable (stereo cable) to be used as a wired remote control. In this case, this jack supplies 5 V to the remote commander as power source.

**OUT jack (stereo minijack):** Connects to the CONTROL S IN jack of other Sony equipment.

#### Note

When using this jack, the remote control detector on the projector does not function.

### ⑦ INDEX NO. switches

When multiple projectors are connected, set the index number of each projector.

To display the index number on the screen, press the NORMAL key, and the ENTER key on the remote commander.

#### Note

If you set the index number to “00,” the projector does not operate.

### ⑧ AC IN socket

Connect the supplied AC power cord.

### ⑨ MAIN POWER switch



# Switching the 75-ohm Terminate Connectors

Depending on the connections of the computer and color monitor to the projector, it may be necessary to switch the 75-ohm terminate connectors on the B board at the rear of the projector.

## Removing the B board

- 1** Remove the rear cover.  
*For details, see “Removing the Upper, Front and Rear Covers” on pages 17 and 18.*
- 2** Loosen the four screws at the rear of the projector to remove the connector panel.

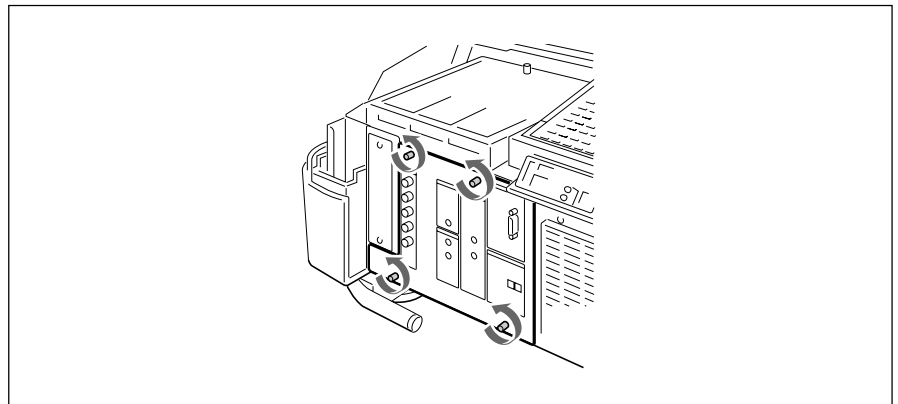

- 3** Loosen the screw and remove the cover.

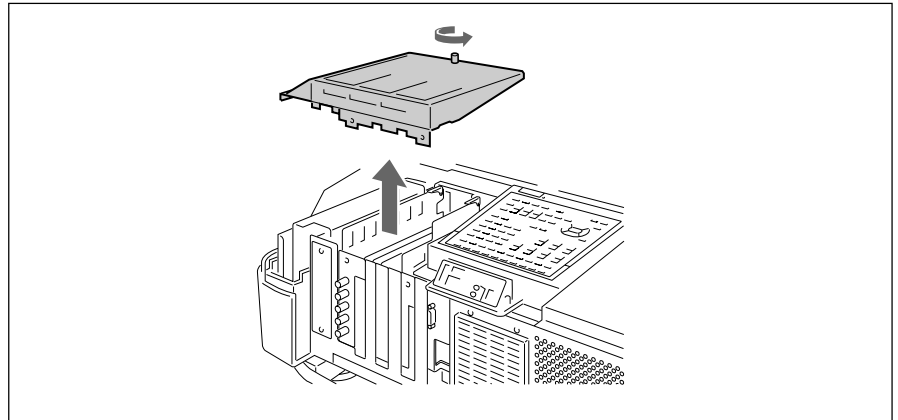

(continued)

## Switching the 75-ohm Terminate Connectors

- 4** Open the wire holder and pull up the B and BA boards carefully while lifting up the card puller. Be careful not to pull the wires.

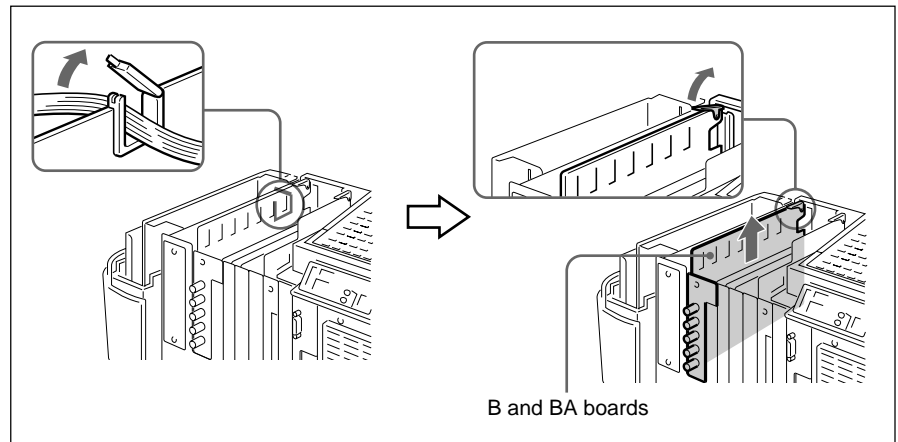

- 5** Switch the CN35, CN36 and CN37 connectors on the B board.  
For details, see “Setting the CN35 (R), CN36 (G) and CN37 (B) 75-ohm terminate connectors.”

- 6** Perform the steps **1** to **4** above in the reverse order to replace the B and BA boards.

### Setting the CN35 (R), CN36 (G) and CN37 (B) 75-ohm terminate connectors

75  $\Omega$  (pin position 3): This position is selected at the factory.  
OPEN (pin position 1): Set to this position when the input signal is distributed into other equipment using a branch connector and is terminated at 75 ohms on that equipment.

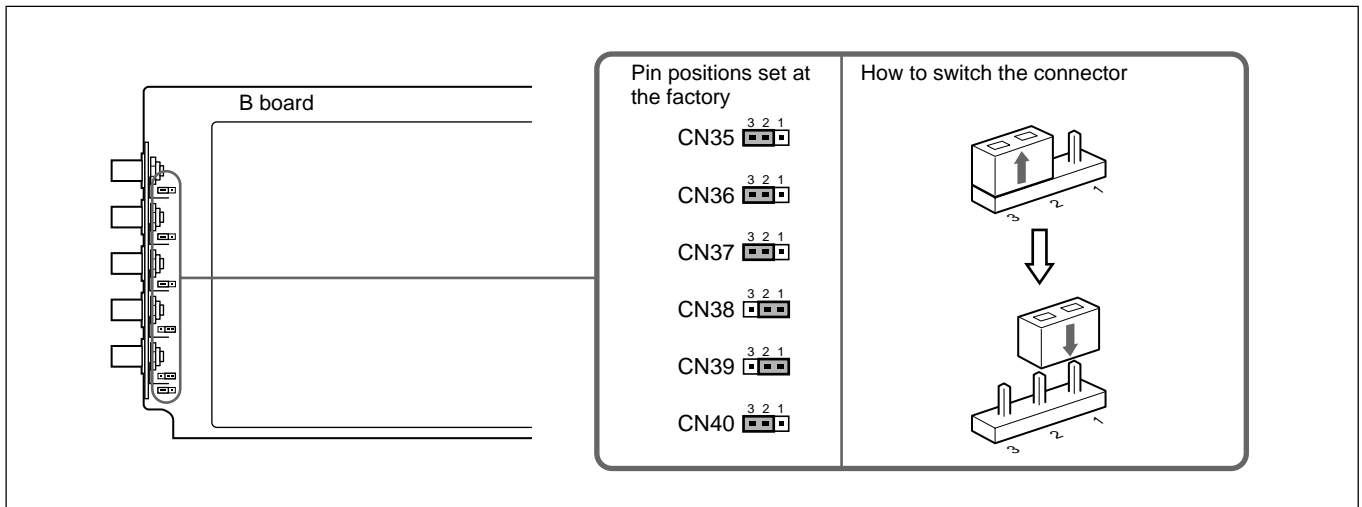

#### Note

The pin positions of the CN38, CN39 and CN40 connectors are set at the factory as illustrated. Do not change the settings.

# Connecting Directly to the Projector

You can expand the system connections by installing the IFB-40 Signal Interface Board (not supplied) to the projector, or in combination shown in the examples below.

## When multiple input sources are connected to the projector

Use the IFU-1271/1271M Signal Interface Unit.

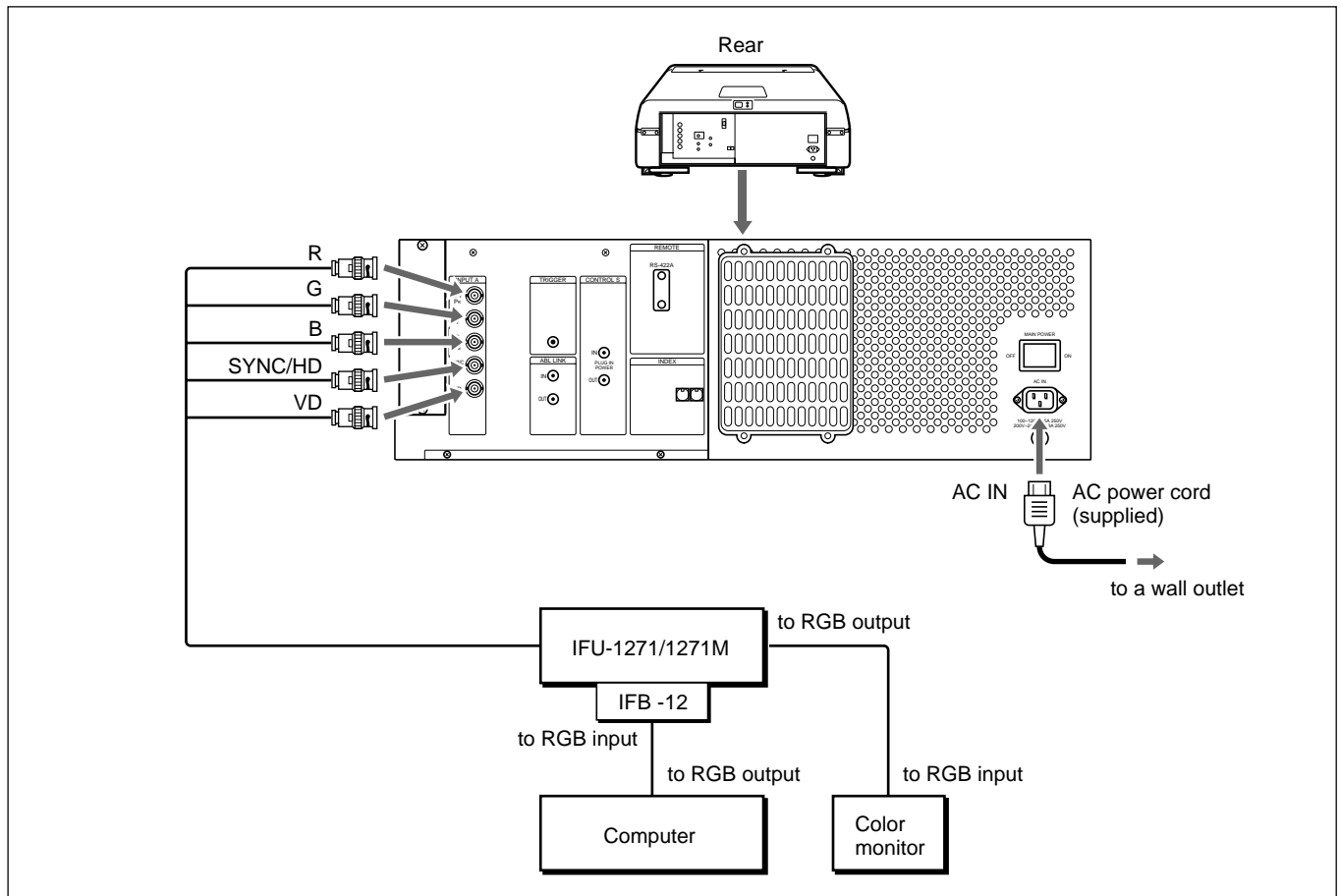

### Setting up

- Set INPUT-A in the SET SETTING menu to RGB.  
*For details, see "The SET SETTING Menu" on page 49.*
- Switch the 75-ohm terminate connectors according to the connections of the computer and color monitor.  
*For details, see "Switching the 75-ohm Terminate Connectors" on page 25.*

# Using the Signal Interface Switcher

When you install the IFB-40 Signal Interface Board (not supplied) to the projector and connect the PC-1271/1271M Signal Interface Switcher (not supplied) to the IFB-40, you can connect easily various input sources. You can select up to 16 inputs by pressing the SWITCHER/INDEX keys on the remote commander or by setting SWITCHER in the INPUT SELECT menu.

## When the switcher is connected to the projector using the SIC-M or CCQ-BRS connecting cable

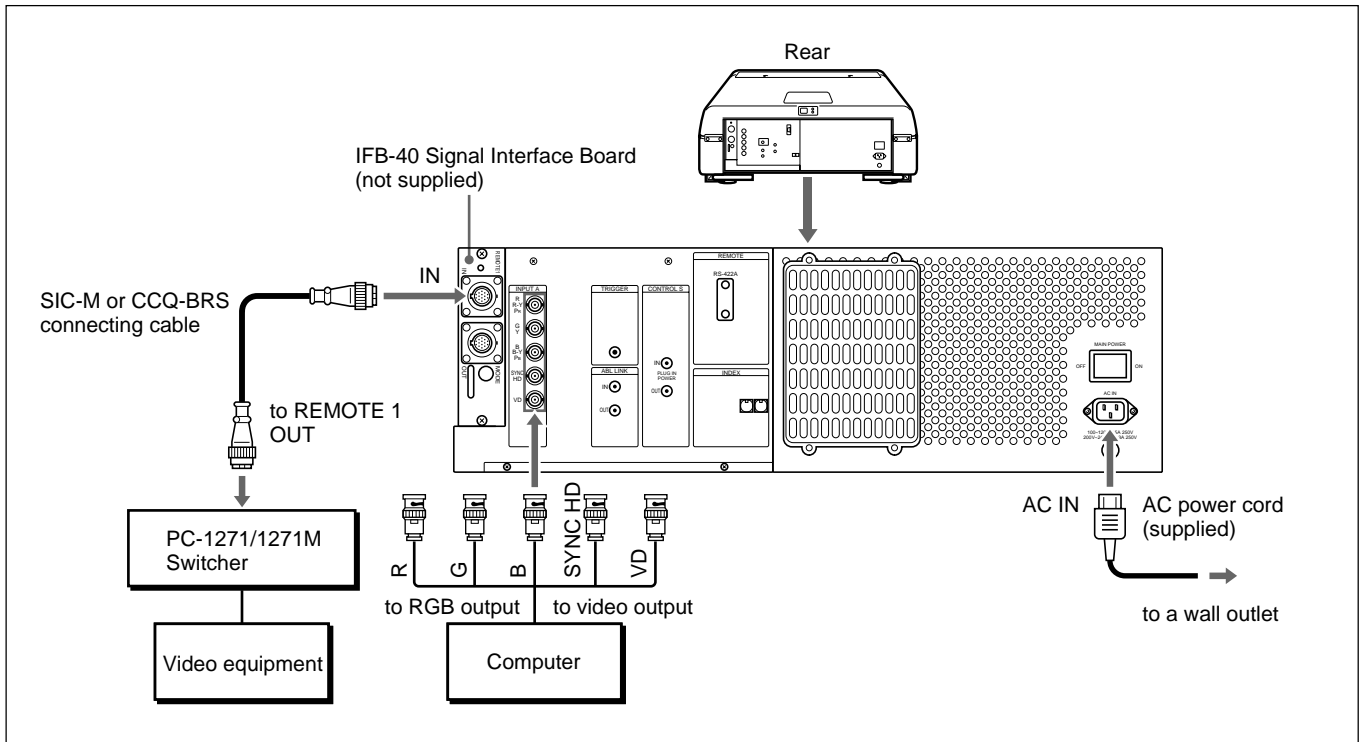

Choose the appropriate cable from the following table.

1 m	2 m	5 m	10 m	15 m	25 m	50 m
—	CCQ-2BRS	CCQ-5BRS	CCQ-10BRS	—	CCQ-25BRS	CCQ-50BRS
SIC-M-1	—	SIC-M-5	—	SIC-M-15	SIC-M-25	SIC-M-50

### Notes

- Insert the female and male plugs of the SIC-M or CCQ-BRS cable correctly.
- You can extend the SIC-M or CCQ-BRS cable up to 50 m.
- The video signal input to the signal interface board installed to the INPUT B section should not exceed 70 MHz. When projecting the video signal which exceeds 70 MHz, connect the signal source to the INPUT A connectors using the 5BNC cables.

### Setting up

- Set INPUT-A in the SET SETTING menu to RGB.  
*For details, see “The SET SETTING Menu” on page 49.*
- Set the SINGLE/SECOND/OTHER select switch on the switcher to SINGLE.

## When the switcher is connected to the projector using the 5BNC cables (5BNC mode)

When the switcher to be connected is more than 50 m away from the projector, or the SIC-M or CCQ-BRS cable cannot be used for the connection between the projector and switcher, connect the RGB signal sources to the switcher.

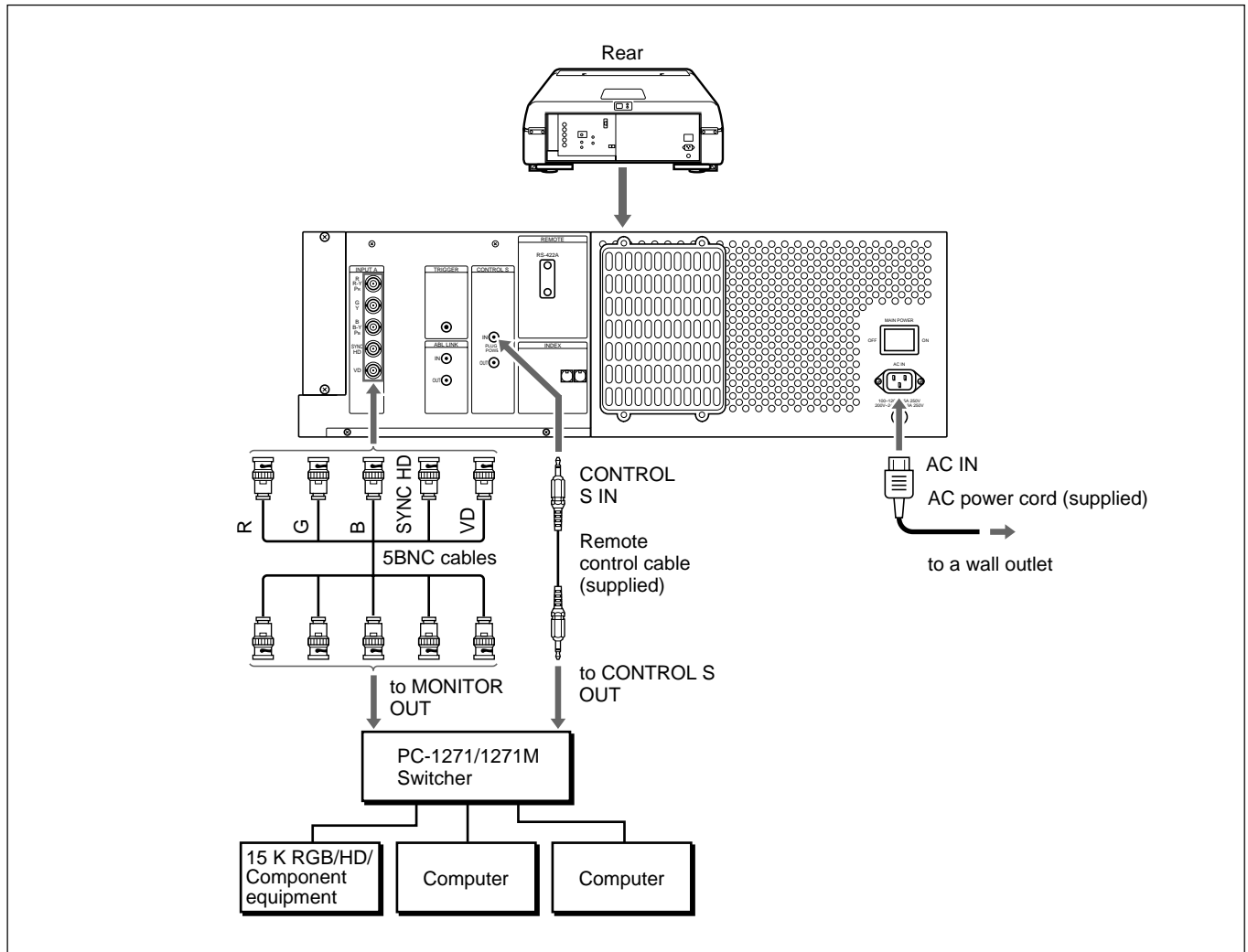

### Setting up

- Set INPUT-A to RGB and 5BNC MODE to ON in the SET SETTING menu.

*For details, see “The SET SETTING Menu” on pages 49 and 51.*

- Set the SINGLE/SECOND/OTHER select switch on the switcher to SINGLE.
- When the HDTV signal is input to the switcher, set the output of the connected equipment or the IFB-1301 Signal Interface Board installed to the switcher to GBR OUT.
- When the component signal is input to the switcher, set the output of the connected equipment or the IFB-1200 Signal Interface Board installed to the switcher to RGB OUT.

# Using the Signal Interface Switcher

## When two signal interface switchers are connected

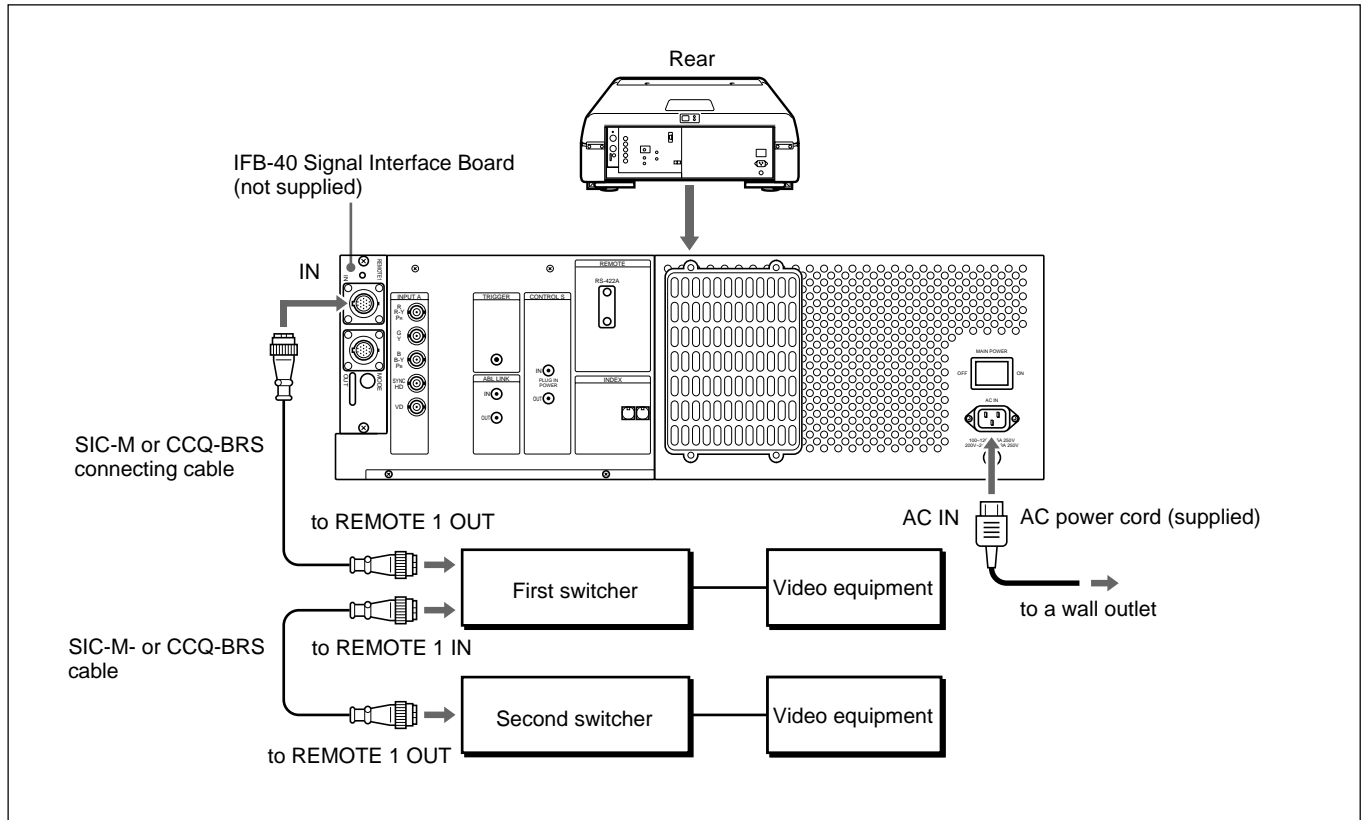

### Notes

- Insert the female and male plugs of the SIC-M or CCQ-BRS cable correctly.
- You can extend the SIC-M or CCQ-BRS cable between the projector and the switcher up to 50 m.
- The video signal input to the signal interface board installed to the INPUT B section should not exceed 70 MHz.

### Setting up

- Set the SINGLE/SECOND/OTHER select switch on the first switcher to SINGLE.
- Set the SINGLE/SECOND/OTHER select switch on the second switcher to SECOND.

# Connecting Multiple Projectors

When connecting multiple projectors, you can project the multi-screen picture.

## When the projectors are connected using the SIC-M or CCQ-BRS cable

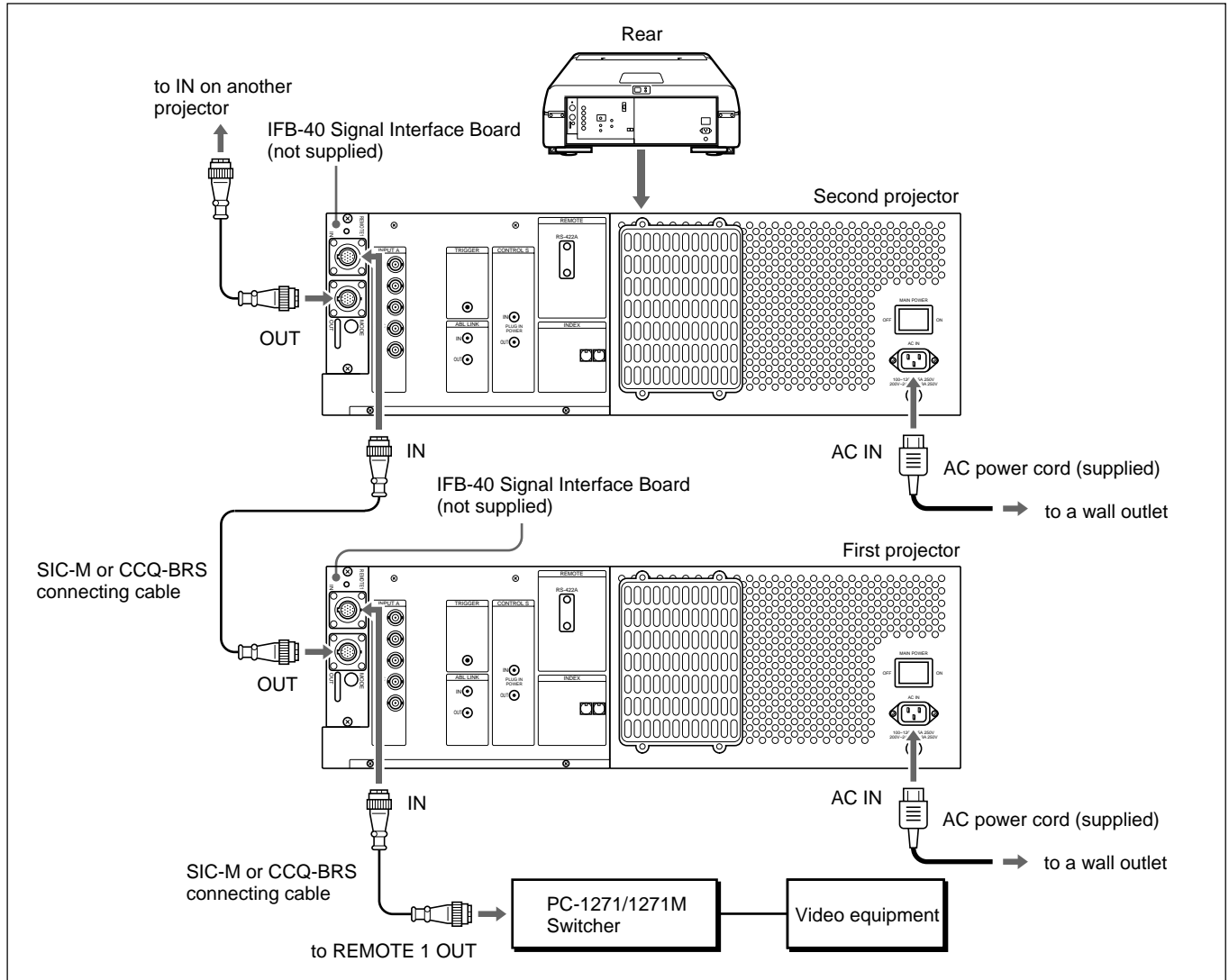

### Notes

- Insert the female and male plugs of the SIC-M or CCQ-BRS cable correctly.
- You can extend the SIC-M or CCQ-BRS cable between the projector and the switcher up to 50 m.
- The video signal input to the signal interface board installed to the INPUT B section should not exceed 70 MHz.

### Setting up

- Set the SINGLE/SECOND/OTHER select switch on the switcher to SINGLE.
- To control the projectors using the index number, set the sequential number from 01 to 08 on each projector using the INDEX NO. switches on the rear panel.

# Connecting Multiple Projectors

## Using the Linked ABL Function

### What is linked ABL function?

The ABL (Automatic Brightness Limiter) function is incorporated with the projector. The ABL function prevents CRT burn by controlling the brightness of the screen if it becomes too high.

If you connect the ABL LINK jacks of each projector when connecting multiple projectors to display a multi-screen, the ABL functions on all projectors once the ABL functions on any one projector. The linked ABL function allows the multi-screen's brightness uniform.

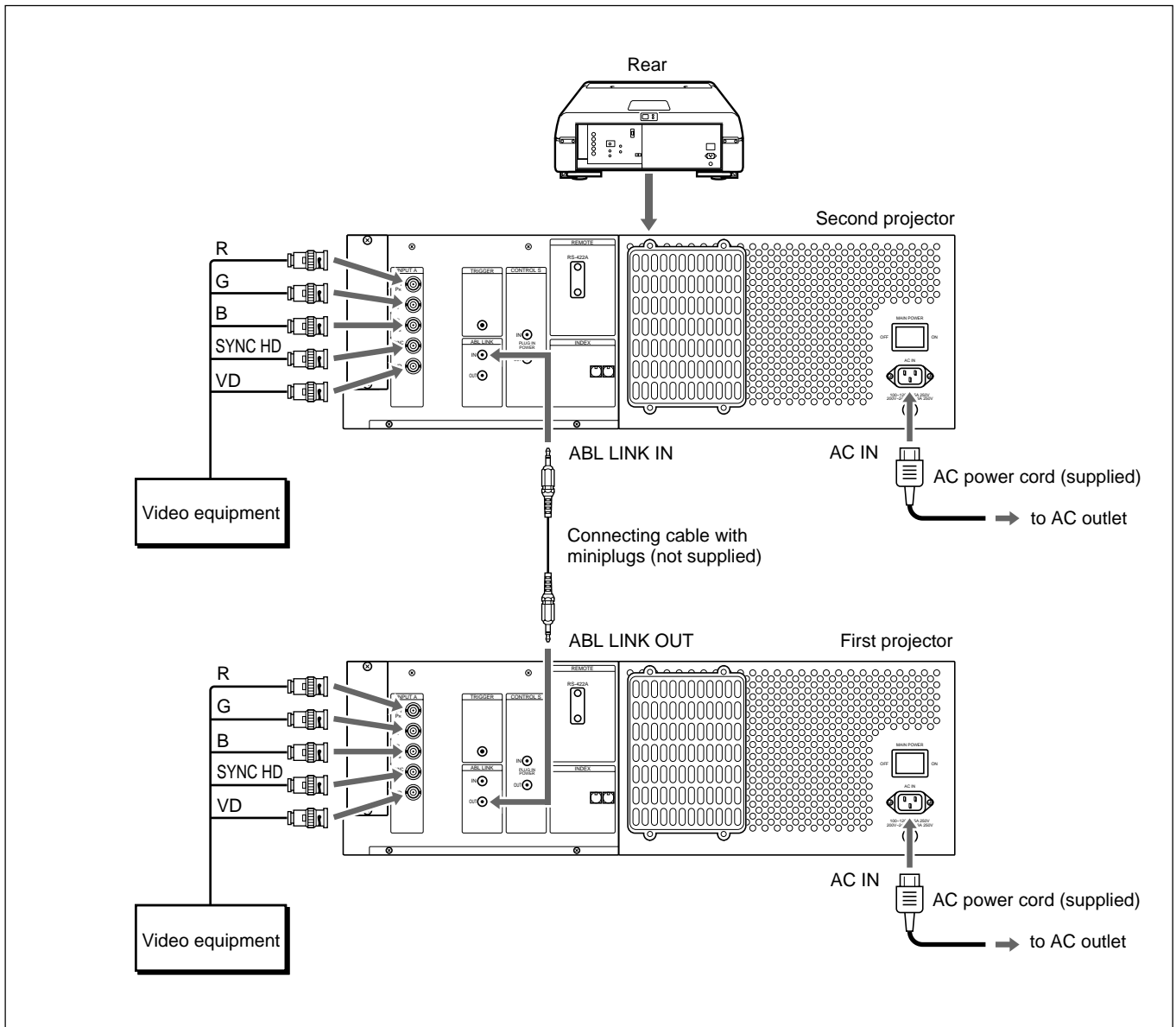

### Setting up

Set ABL LINK in the ABL LINK menu to ON.  
For details, see "The ABL LINK Menu" on page 56.



## Adjusting the ABL LINK

- 1** Set the remote control to the service adjustment mode.  
*For details, see "Preparation" on page 36.*
- 2** Set the CONTRAST levels of all projectors to the same level.
- 3** Adjust the brightness of each projector to make its black level uniform.
- 4** Input an external signal to display the 1/16 window pattern.
- 5** Display the ABL LINK menu, select SUB CONTRAST with the **▲** or **▼** key, then press the ENTER key.  
*For details, see "The ABL LINK Menu" on page 56.*

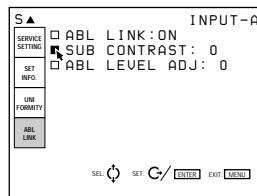

- 6** Press the **▲** or **▼** key to adjust the projector so that the brightness looks the same as that of the darkest projector, then press the ENTER key.

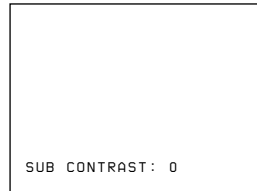

- 7** Repeat steps **4** to **6** on each projector so that the brightness of all projectors looks the same.
- 8** Input an external signal to display the all white pattern.
- 9** Select ABL LEVEL ADJ in the ABL LINK menu, then press the ENTER key.
- 10** Press the **▲** or **▼** key to adjust the projector so that the brightness looks the same as that of the darkest projector, then press the ENTER key.

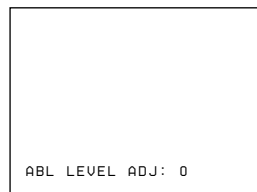

- 11** Repeat steps **8** to **10** on each projector so that the brightness of all projectors looks the same.
- 12** Set ABL LINK in the ABL LINK menu to ON, then press the ENTER key.  
If the ABL functions on any one projector, the brightness of all projectors becomes uniform.

# Before adjustment

## Adjustment Procedures

### Warm-up before adjustment

Before adjusting the registration, make sure to turn on the projector and allow it to warm up for 20 minutes.

The projector is designed with a warm-up period of about 20 minutes after turning on the power. During this period, it displays a white screen with the message shown below. 35 seconds after the warm-up starts, the message will disappear temporarily and will appear subsequently for 5 seconds every 30 seconds.

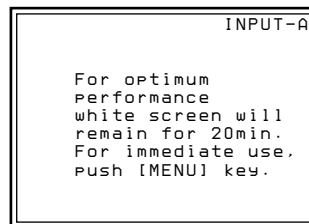

Press the MENU key to cancel the warm-up, if you wish to see the picture immediately.

You may also set the projector for a shorter, longer or no warm-up period. For details, see “Changing the Initialization Period” on page 113.

---

## Adjustment procedures

Perform each adjustment with the supplied remote commander before connecting to the external equipment. After the adjustment, save the data. Next, perform fine adjustment for each input signal connected to the projector.

Follow the procedure below.

- ① Prepare the remote commander. *(page 36)*  
↓
- ② Set the projector to the service adjustment mode. *(page 37)*  
↓
- ③ Adjust roughly without input signal. *(pages 64 to 96)*  
↓
- ④ Save the adjustment data as the standard data. *(page 97)*  
↓
- ⑤ Adjust finely for each input signal. *(pages 98 to 106)*  
↓
- ⑥ Activate the memory protection of the remote commander. *(page 111)*  
↓
- ⑦ Adjust the picture. *(page 112)*

# For Remote Control

All adjustments, except focusing the lens and adjusting flapping of the lens, can be made with the supplied remote commander. Normally, the adjustment keys on the remote commander are inoperable to prevent accidental adjustments. Cancel the protection before adjusting. Since the remote commander uses infrared, you can use it without a wire. However, in order to correctly control the projector, you should connect the remote commander to the projector with the supplied remote control cable.

## Preparation

- 1** Insert three of the supplied R6 (size AA) batteries with the polarities lined up correctly.  
*For details, see “Battery installation” on page 37.*
- 2** Connect the remote commander to the projector.  
*See “Connecting the remote commander to the projector” on page 38.*
- 3** Make sure that the COMMAND ON/OFF switch on the remote commander is set to ON.
- 4** Turn on the MAIN POWER switch on the projector, and then press the POWER ON key on the remote commander.
- 5** Open the panel cover of the adjustment keys.

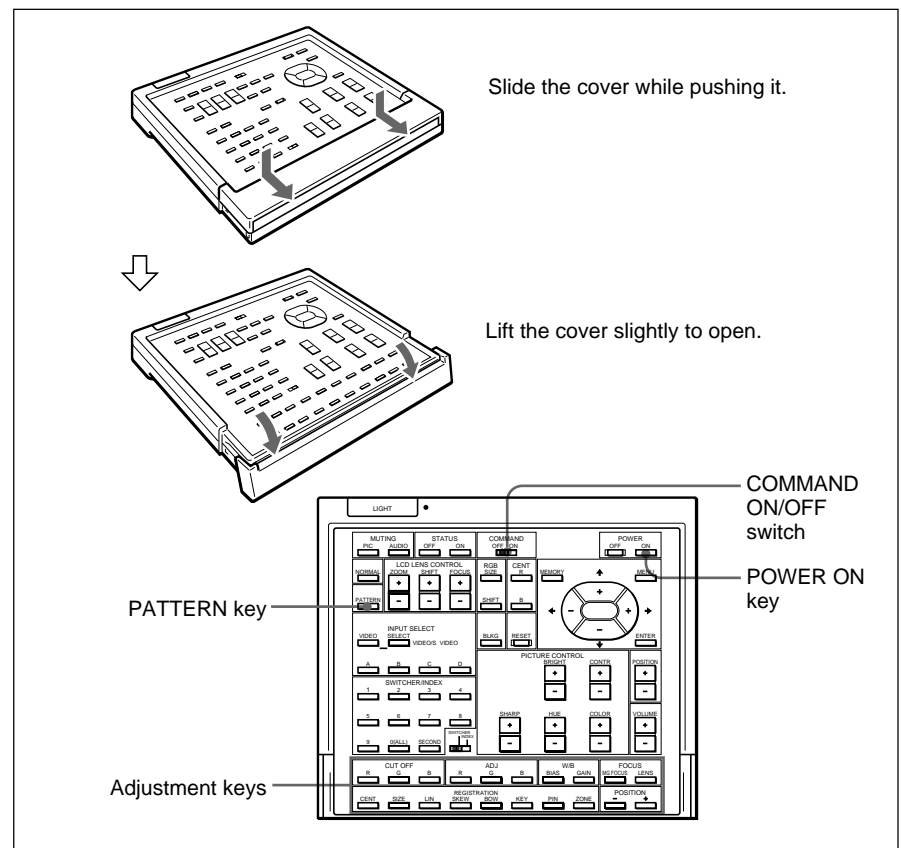

- 6** Press the keys in the following order:  
ENTER → ENTER → ▲ → ▼ → ENTER

The following display appears.

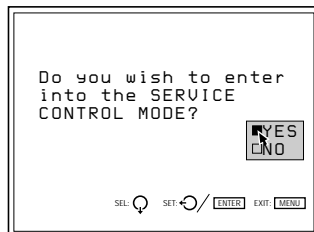

- 7** Press the ▲ or ▼ key to select YES, then press the ENTER key.

The protection on the adjustment keys is removed and the service adjustment keys are enabled (service adjustment mode).

After the adjustment, reactivate the protection.

*For details, see “Protecting the Setting” on page 111.*

#### **Notes for wireless remote control operation**

- Be sure that there are no obstructions between the remote commander and the projector.
- Operating range is limited. The shorter the distance between the remote commander and the projector, the wider the angle in which the remote commander can control the projector.

## **Battery installation**

- 1** Push to open the lid.

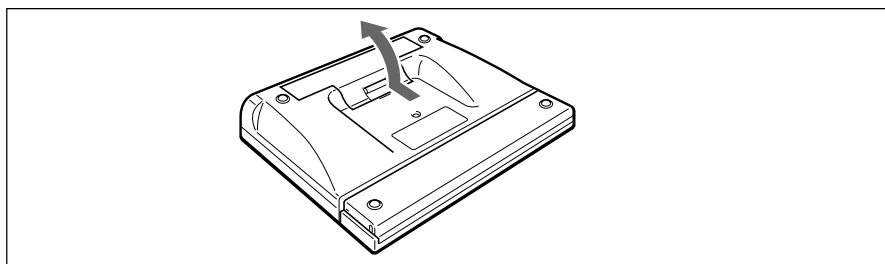

- 2** Install three R6 (size AA) batteries (supplied) with the correct polarity.

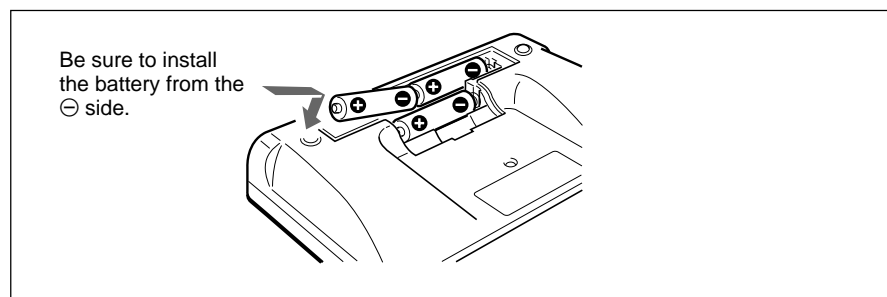

(continued)

### 3 Replace the lid.

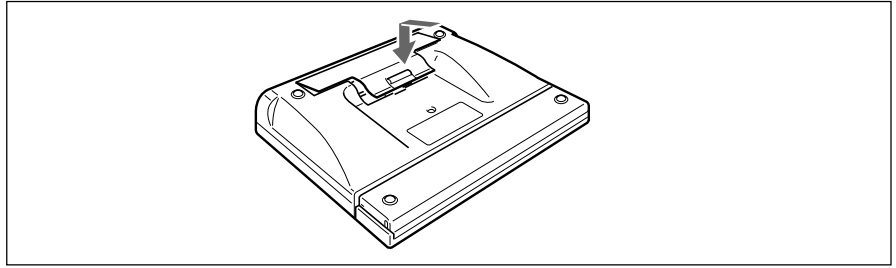

#### Notes on batteries

- If the projector does not operate properly, the batteries might be worn out. Replace all three of them with new ones.
- The life of the batteries depends on frequency of usage and how often you use the LIGHT button. If they are worn out quickly, replace them with new alkaline batteries.
- To avoid damage from possible battery leakage, remove the batteries when the remote commander will not be used for a long time.

## Connecting the remote commander to the projector

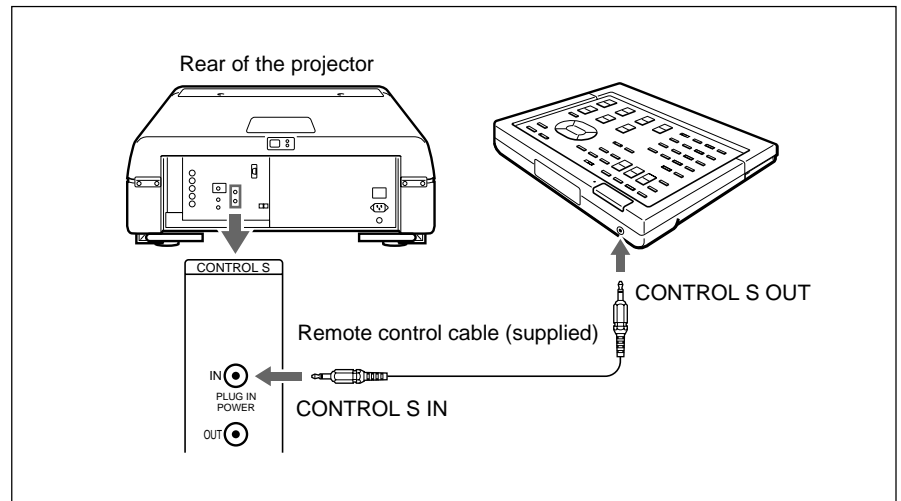

#### Note

When you connect the remote commander to the projector as mentioned above, the remote control detector of the projector does not function. For wireless operation, be sure to disconnect both plugs from the projector and the remote commander.

## Keys on the Remote commander

### Notes

- The VOLUME +/- **14**, FOCUS LENS **16**, INPUT SELECT VIDEO, SELECT, C and D **24**, AUDIO MUTING **28** and LCD LENS CONTROL **29** keys do not function with this projector.
- The MG FOCUS **15**, W/B BIAS/GAIN **18**, REGISTRATION **19**, ADJ R/G/B **20** and CUT OFF R/G/B **21** keys function only in service adjustment mode.

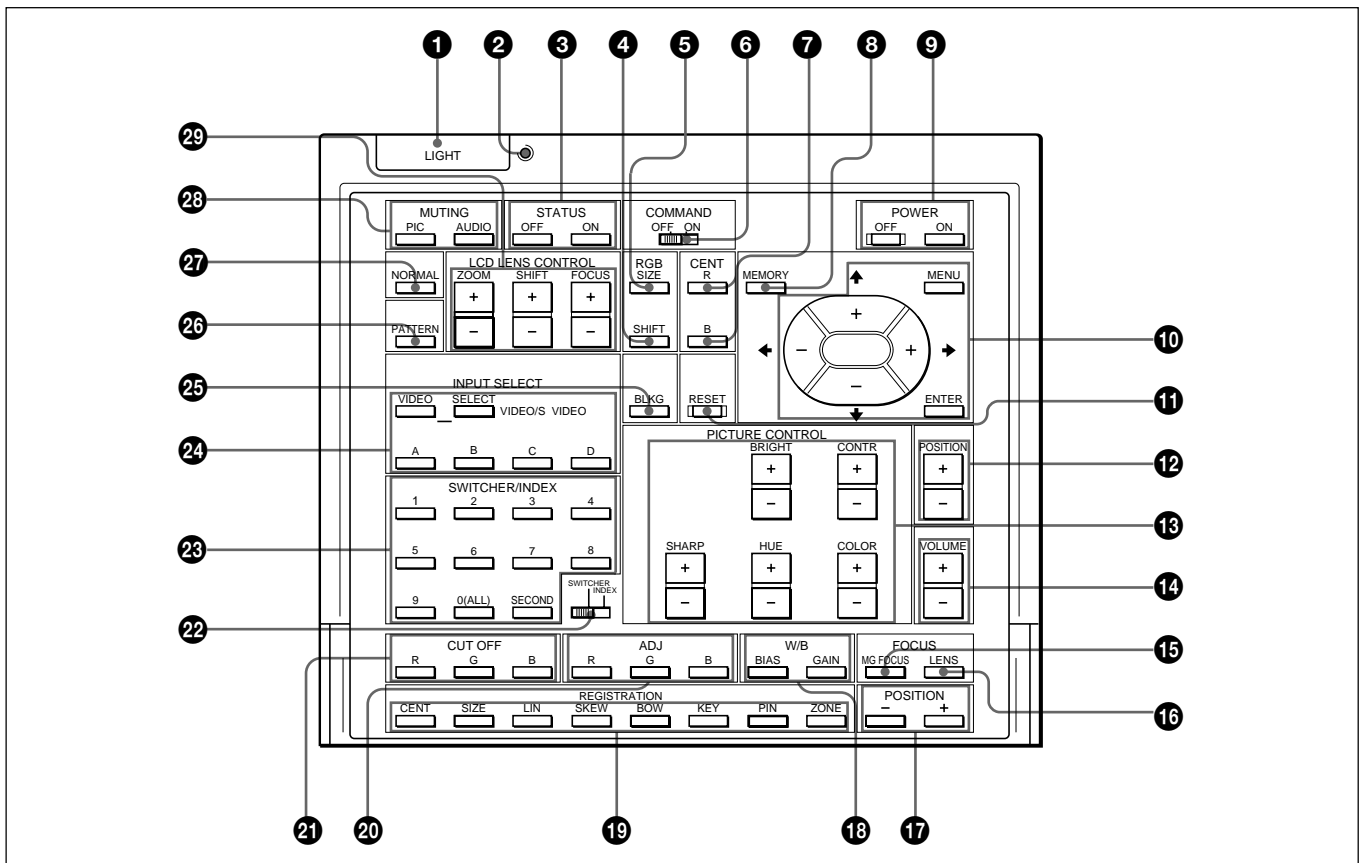

### 1 LIGHT button

Illuminates the key indicators when the COMMAND switch **6** is set to ON. If the COMMAND switch is set to OFF, only the COMMAND switch is illuminated.

The key indicators turn off if you press the LIGHT button again.

If you do not press any key for more than 30 seconds, the indicators also turn off automatically.

When the remote commander is connected to the CONTROL S IN/PLUG IN POWER jack of the projector via the remote control cable, the power is supplied to the remote commander from the projector.

### 2 Transmission indicator

Lights each time you press a key. If it does not light, replace the batteries with new ones.

### 3 STATUS ON/OFF key

Press OFF to eliminate the on-screen display.

Press ON to restore the on-screen display.

### Note

The menus and warning messages appear even if the OFF key is pressed.

## For Remote Control

### ④ RGB SHIFT key

Enters the shift adjustment mode for the input signal. Next adjust the position of the picture using the four arrow keys. The picture shifts in the direction of the arrow on the pressed key.

Press the MEMORY key ⑧ to store the adjusted value and display the adjusted picture.

### ⑤ RGB SIZE key

Enters the size adjustment mode for the input signal. Next adjust the size of the picture using the four arrow keys.

← : to reduce horizontal size

→ : to expand horizontal size

↑ : to expand vertical size

↓ : to reduce vertical size

Press the MEMORY key ⑧ to store the adjusted value and display the adjusted picture.

### ⑥ COMMAND ON/OFF switch

No keys on the remote commander except the LIGHT button ① function when this switch is set to OFF. This saves battery power.

### ⑦ CENT R/B keys

Enter the centering adjustment mode of the red and blue.

**R:** Press to enter the red centering adjustment mode.

**B:** Press to enter the blue centering adjustment mode.

Perform the centering adjustment using the four arrow keys.

### ⑧ MEMORY key

Stores various adjusted data into memory.

### ⑨ POWER ON/OFF keys

Turn on and off the projector when the MAIN POWER switch on the projector is set to ON.

### ⑩ Menu operation keys

Used for various adjustment functions and for menu operations.

**MENU:** Displays the main menu. Press it again to turn off the menu.

**Arrow keys:** Adjusts the value or selects the item in the menu.

**ENTER:** Stores the settings in the menu.

### ⑪ RESET key

Resets the adjusted levels to the factory preset or service adjusted levels.

### ⑫ POSITION +/- keys

Select the position to be adjusted on the screen in focus, registration or blanking adjustment mode.

Also, set V SHIFT to WIDE or NARROW in RGB input signal's SHIFT adjustment mode.

### ⑬ PICTURE CONTROL keys

Adjust the picture conditions: CONTR (contrast), BRIGHT (brightness), COLOR, HUE and SHARP (sharpness).

### ⑭ VOLUME +/- keys

These keys do not function with this projector.

### ⑮ MG FOCUS key

Enters the magnetic focus, AQP or DQP adjustment mode.

*For details, see "Adjusting the green magnetic focus and AQP/DQP" on page 70.*

### ⑯ FOCUS LENS key

This key does not function with this projector.

### ⑰ POSITION +/- keys

Function the same as the POSITION +/- ⑫ keys. Select the position to be adjusted on the screen in focus, registration or blanking adjustment mode.

### ⑱ W/B (white balance) keys

Enter the white balance adjustment mode.

**BIAS:** Adjusts cut off.

**GAIN:** Adjusts drive.

### ⑲ REGISTRATION keys

CENT/SIZE/LIN/SKEW/BOW/KEY/PIN/ZONE

Select the desired item for registration adjustment with each key, then adjust the item with the arrow keys.

*For details, see "Keys for Adjusting" on page 77.*

### ⑳ ADJ R/G/B (adjust red/green/blue) keys

Select color to be adjusted when adjusting the focus, registration and white balance adjustments.

**R:** Red signal

**G:** Green signal

**B:** Blue signal

### ㉑ CUT OFF keys

Select the color to be turned off when adjusting the registration. Press again to turn on the color.

**R:** Red signal

**G:** Green signal

**B:** Blue signal



**22 SWITCHER/INDEX select switch**

Selects the function of the SWITCHER/INDEX keys. Set to SWITCHER to select the input from the PC-1271/1271M Signal Interface Switcher. Set to INDEX to assign the index number of each projector when multiple projectors are used.

**23 SWITCHER/INDEX keys****When the SWITCHER/INDEX select switch is set to SWITCHER**

When the PC-1271/1271M switcher (not supplied) is connected to the projector via the optional IFB-40 Signal Interface Board installed to the projector, press a number key (1 – 8) to select the input from the switcher. The number key 9 does not function. To select the input from the second switcher (when the SINGLE/SECOND/OTHER switch on the switcher is set to SECOND), press a number key between 1 and 8 within two seconds after pressing the SECOND key.

**When the SWITCHER/INDEX select switch is set to INDEX**

When multiple projectors are connected, select the index number, which is set with the INDEX NO. switch on the rear panel, of the projector to be adjusted. Press a number key (1 – 9) to designate the index number, then press the ENTER key. When adjusting all the projectors simultaneously, press the 0 (ALL) key, then the ENTER key.

**24 INPUT SELECT keys**

Select the input signal.

**VIDEO:** This key does not function with this projector.

**SELECT VIDEO/S VIDEO:** This key does not function with this projector.

**A:** The RGB, component or HDTV signal input from the INPUT A connectors of the projector

**B:** The signal input from the INPUT B section when the optional interface board other than the IFB-40 is installed

**C, D:** These keys do not function with this projector.

**25 BLKG (blanking) key**

Enters the blanking adjustment mode.

You can adjust the blanking with the four arrow keys. For details, see “Blanking Adjustment” on pages 101 and 104.

**26 PATTERN key**

Displays the internal test patterns of the projector. Each press of the key advances the test pattern sequentially.

In the focus, registration or white balance adjustment mode, only the test patterns suitable for the adjustment will be displayed.

For details, see “Test Patterns” on page 61.

**27 NORMAL key**

Erases the test pattern or cancels the various adjustment modes.

**28 MUTING keys**

**PIC (Picture):** Cuts off the picture. To restore the picture, press the key again.

**AUDIO:** This key does not function with this projector.

**29 LCD LENS CONTROL keys**

These keys do not function with this projector.

# Using the MENU

The projector is equipped with an on-screen menu for making various adjustments and settings. The language used in the menu can be changed to French, German, Italian, Spanish, Japanese or Chinese. For details, see “LANGUAGE” on page 50.

## Basic Menu Operation

- 1 Press the MENU key.  
The menu display appears.  
The menu presently selected is highlighted in blue.

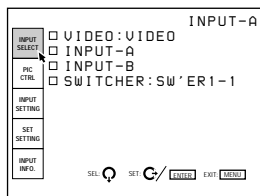

- 2 Use the ↓ or ↑ keys to select a menu, then press the → key or the ENTER key.  
The selected menu appears.  
The setting items that are indicated in white cannot be selected.

Menu items    Setting items

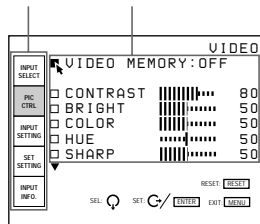

- 3 Use the ↓ or ↑ keys to select a setting item, then press the → key or the ENTER key.  
The adjustment menu or the setting menu (pop-up menu) appears.

### If there are two or more pages for a menu

The ▼ indication appears below the bottom item. To go to the next page, move the cursor to the bottom item with the ↓ key, then press the ↓ key. To go back to the previous page, move the cursor to the top item with the ↑ key, then press the ↑ key.

- 4 Make adjustment or setting on the menu.

### To change the adjustment level

To increase the level, press the ↑ or → key.  
To decrease the level, press the ↓ or ← key.  
Then press the ENTER key to store the level. The original screen is restored.

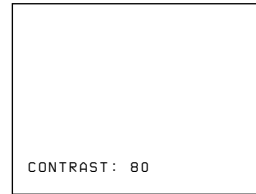

### To select an item

Use the ↓ or ↑ key to select an item in a pop-up menu, then press the ← key or the ENTER key. The selected setting is stored and the pop-up menu disappears.

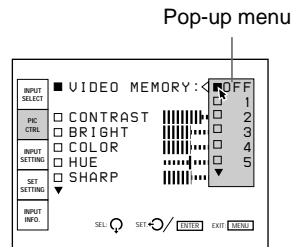

For details on setting individual items, see the relevant menu pages.

### To clear the menu display

Press the MENU key.  
The menu display also disappears automatically if no key is pressed for about one minute.

### To reset the settings that have been adjusted

Press the RESET key. “Reset complete!” appears on the screen and the settings appearing on the screen will be reset to the factory preset or service adjusted levels.

### Memory of the settings

The settings in the menus are automatically stored in the projector memory. You can also store the settings by pressing the MEMORY key.

## The INPUT SELECT Menu

The INPUT SELECT menu is used for selecting the input signal.

Items that can be selected are highlighted in green. You cannot select the items indicated in white.

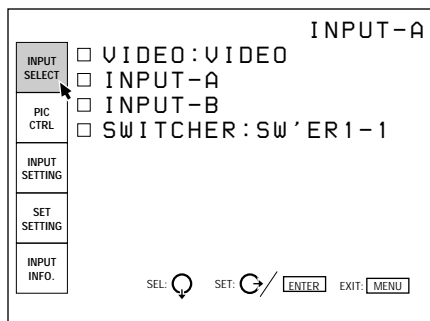

## VIDEO

This item cannot be selected with this projector.

## INPUT-A

Selects signal input from the INPUT A connectors.

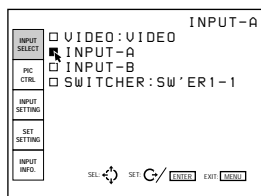

### Notes

- When the INPUT A connectors are connected to the PC-1271/1271M Switcher with 5BNC cables, INPUT-A cannot be selected.
- If the setting of INPUT-A in the SET SETTING menu is incorrect, the picture may be distorted.  
*For details, see page 49.*

## INPUT-B

Selects signal input from the connectors on the optional signal interface board installed to the INPUT B section.

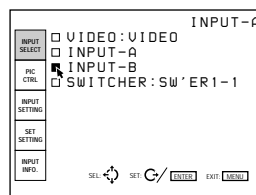

### Notes

- When the PC-1271/1271M Signal Interface Switcher is connected to the projector via the IFB-40 Signal Interface Board installed to the INPUT B section, INPUT-B cannot be selected.
- If the setting of INPUT-B in the SET SETTING menu is incorrect, the picture may be distorted.  
*For details, see page 49.*

## SWITCHER

When the PC-1271/1271M Signal Interface Switcher is connected to the projector, selects signal input from the switcher.

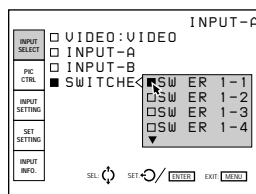

You can select SW'ER1-1 to SW'ER2-8 in the pop-up menu. They are always displayed in green even when no signal is input.

### Note

SWITCHER can be selected only when the IFB-40 Signal Interface Board is installed to the INPUT B section, or when 5BNC MODE in the SET SETTING menu is set to ON.

# Using the MENU

## The PIC CTRL (Picture Control) Menu

The PIC CTRL menu is used for adjusting the picture. Items that can be adjusted are highlighted in green. You cannot select the items indicated in white.

### Page 1

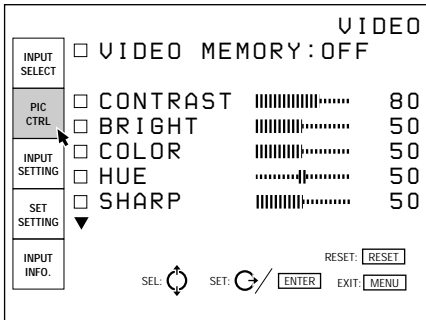

### Page 2

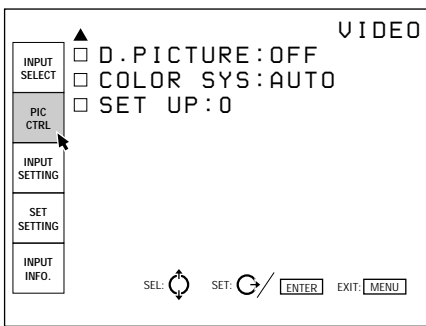

Before adjustment

## VIDEO MEMORY

Selects a memory number of the adjusted picture levels.

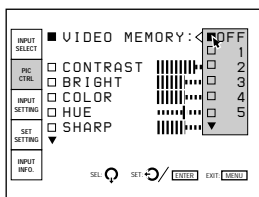

Select a number from 1 to 10 in the pop-up menu, then the picture levels that have been adjusted will be stored in the number of the projector's memory.

If you want to use the data at the factory preset levels, select OFF.

The items to be stored in the VIDEO MEMORY are shown in the table of the memory architecture under "Input memory" (except for the items, "clamp position" and "registration"). (page 108)

## CONTRAST

Adjusts the picture contrast.



The higher the setting, the greater the contrast. The lower the setting, the lower the contrast.

## BRIGHT (brightness)

Adjusts the picture brightness.



The higher the setting, the brighter the picture. The lower the setting, the darker the picture.

## COLOR

Adjusts color intensity.

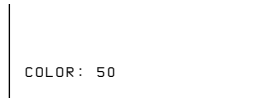

The higher the setting, the greater the intensity. The lower the setting, the lower the intensity.

## HUE

Adjusts skin tones.

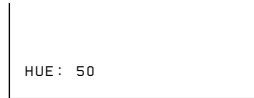

At high settings, the picture becomes greenish. At low settings, the picture becomes purplish.

## SHARP (sharpness)

Adjusts the picture sharpness.

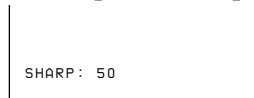

The higher the setting, the sharper the picture. The lower the setting, the softer the picture.

## D. (Dynamic) PICTURE

Emphasizes the black of the composite video, S video (Y/C) or component signal.

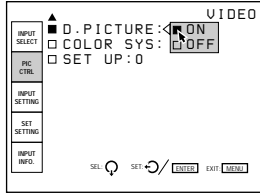

**ON:** Emphasizes the black to produce a bolder “dynamic” picture.

**OFF:** Reproduces the dark portions of the picture accurately, in accordance with the source signal.

## COLOR SYS (System)

Selects the color system of the composite video or S video (Y/C) signal.

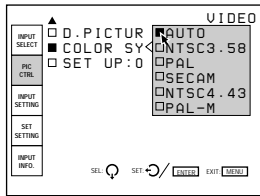

Normally, set to AUTO.

If the picture is distorted or colorless, select the color system according to the input signal.

## SET UP

Changes the set up level (standard black level) to 0 IRE or 7.5 IRE according to the NTSC source signal.

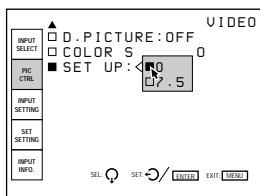

**0 IRE:** Normally, set to this position.

**7.5 IRE:** Set to this position when the black color is too light.

## Input signals and adjustable/setting items

Item	Input signal			
	Video or S video (Y/C)*	Component	HDTV	RGB
CONTRAST	Y	Y	Y	Y
BRIGHT	Y	Y	Y	Y
COLOR	Y	Y	Y	N
HUE	Y (NTSC <sub>3.58</sub> /NTSC <sub>4.43</sub> system only)	N	Y	N
SHARP	Y	Y	Y	N
D. PICTURE	Y	Y	N	N
COLOR SYS	Y	N	N	N
SET UP	Y (NTSC <sub>3.58</sub> /NTSC <sub>4.43</sub> system only)	N	N	N

Y: Adjustable/can be set

N: Not adjustable/cannot be set

\* The optional IFB-1000 Signal Interface Board is required for video or S video (Y/C) signal input.

# Using the MENU

## The INPUT SETTING Menu

The INPUT SETTING menu is used to adjust the input signal.

Items that can be adjusted are displayed in green. You cannot select the items indicated in white.

### Page 1

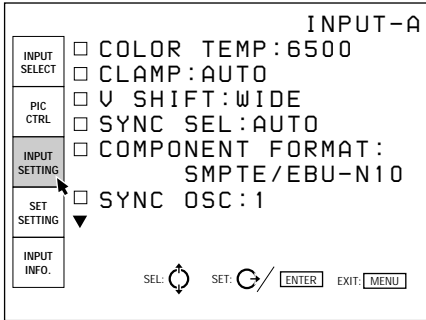

### Page 2

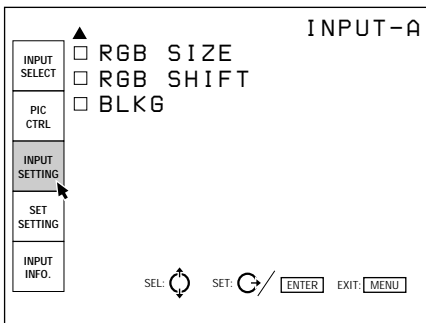

## COLOR TEMP (Temperature)

Selects the appropriate color temperature according to your application and the input source signal.

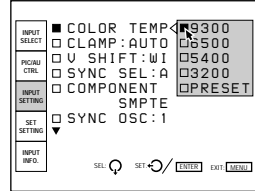

If you wish to make the color of a particular input signal uniform to that of a color monitor, select PRESET, then adjust the white balance.

For details, see "Adjusting the White Balance" on page 105.

## CLAMP

Corrects the luminance of the input picture.

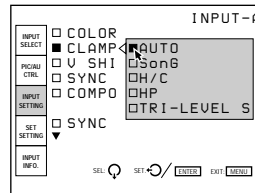

CLAMP is used as a standard for setting the black level of a picture correctly. The standard position of the clamp depends on the kind of sync signal being used. Normally, the projector CPU judges the signal and sets the position automatically. However, the CPU can misjudge the signal because of noise. If the luminance of the picture seems to be incorrect, the clamp position may need to be changed.

**AUTO:** Automatic setting mode. Normally set to this position.

**SonG:** Set to this position if the black seems too light or greenish.

**H/C:** Set to this position if the picture is too dark or luminance is unstable.

**HP:** If the luminance is still incorrect after changing to the SonG or H/C position, set to this position and perform the H-SHIFT adjustment.

**TRI-LEVEL S:** Set to this position if the picture is dark when using the tri-level sync.

### Note

If the luminance is still incorrect after changing the clamp setting, check the input signal and the connections.

Before adjustment

## V (Vertical) SHIFT

Sets the adjustable range of the vertical shift of the input signal.

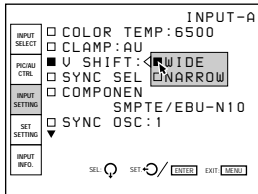

**WIDE:** Normally, set to this position (factory preset).

**NARROW:** When some signal such as a superimposed signal with unstable vertical sync signal is input, the picture may be distorted vertically. In this case, set to this position. Adjustable range in the lower direction will become narrow.

### Note

When the video, S video or component signal is input, V SHIFT is fixed to NARROW.

## SYNC SEL (select)

Selects the sync signal.

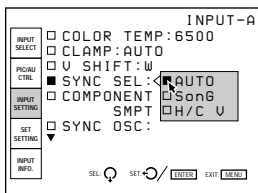

**AUTO:** Automatic setting mode. Normally set to this position.

**SonG:** Set to this position if you project the picture using the sync on G signal.

**H/C V:** Set to this position if you project the picture using the external sync signal.

## When an HDTV signal is input

You can select the items below instead of the above items.

**INT:** Set to this position when using the internal sync signal.

**EXT (C):** Set to this position when using the external composite sync signal.

**EXT (HV):** Set to this position when using the external horizontal/vertical sync signal.

## COMPONENT FORMAT

Selects the format of the component input signal.

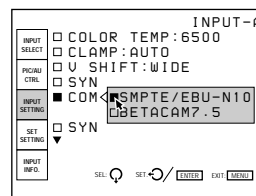

**SMPTE/EBU-N10:** Set to this position if the input signal is the SMPTE or EBU-N10 format component signal.

**BETACAM7.5:** Set to this position if the input signal is the Betacam format component signal.

## SYNC OSC (oscillation)

Normally, set to 1. When synchronization is distorted according to the type of the input signal, set to 2.

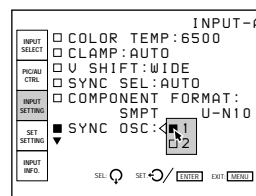

# Using the MENU

## RGB SIZE

Adjusts the picture size of the input signal.

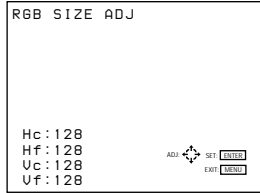

Use the ◀ or ▶ key to adjust the horizontal size.  
Use the ▲ or ▼ key to adjust the vertical size.

Hc and Hf show the size adjustment levels for the horizontal direction and Vc and Vf show those for the vertical direction. The higher the setting level, the greater the picture size.

## RGB SHIFT

Adjusts the picture position of the input signal.

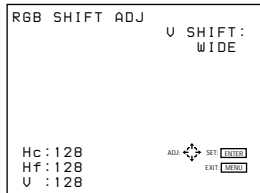

Use the ◀ or ▶ key to adjust the horizontal position.  
Use the ▲ or ▼ key to adjust the vertical position.

Hc and Hf show the shift adjustment levels for the horizontal direction and V shows the level for the vertical direction.

## BLKG (Blanking)

Cuts off the excess parts if the displayed picture is larger than the screen.

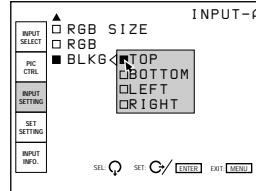

Select the part to be adjusted among TOP, BOTTOM, LEFT and RIGHT, then press the ▶ key or the ENTER key to display the blanking adjustment screen.

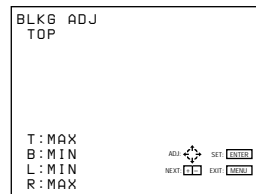

Use the ▲ or ▼ key to adjust the TOP and BOTTOM parts.  
Use the ◀ or ▶ key to adjust the LEFT and RIGHT parts.

## Input signals and adjustable/setting items

Item	Input signal			
	Video or S video (Y/C)*	Component	HDTV	RGB
COLOR TEMP	Y	Y	Y	Y
CLAMP	N	N	Y	Y
V SHIFT	N	N	Y	Y
SYNC SEL	N	N	Y	Y
COMPONENT FORMAT	N	Y	N	N
SYNC OSC	Y	Y	Y	Y
RGB SIZE	Y	Y	Y	Y
RGB SHIFT	Y	Y	Y	Y
BLKG	Y	Y	Y	Y

Y: Adjustable/can be set  
N: Not adjustable/cannot be set

\* The optional IFB-1000 Signal Interface Board is required for video or S video (Y/C) signal input.



## The SET SETTING Menu

The SET SETTING menu is used for changing the default settings of the projector.

Items that can be adjusted are highlighted in green. You cannot select the items indicated in white.

### Page 1

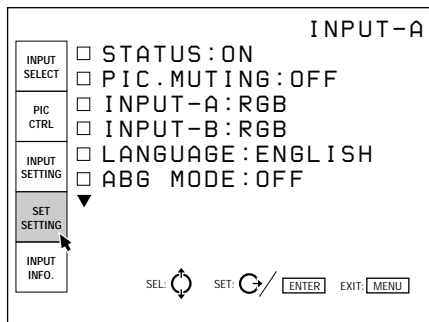

### Page 2

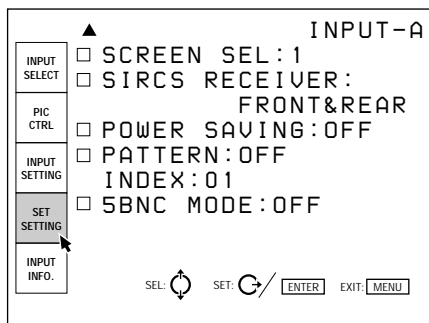

## STATUS

Selects the on-screen display mode.

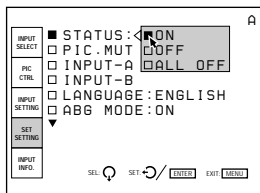

**ON:** Shows all of the on-screen displays.

**OFF:** Turns off the on-screen displays except for “NO INPUT,” “PIC MUTING,” warning messages and menu displays.

**ALL OFF:** Turns off all of the on-screen displays except for warning messages and menu displays.

## PIC. (Picture) MUTING

Set to ON to cut off the picture.

When set to ON, “PIC MUTING” appears on the screen.

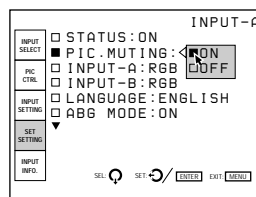

## INPUT A

Selects the signal input from the INPUT A connectors.

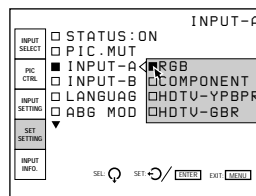

**RGB:** Inputs the RGB signal.

**COMPONENT:** Inputs the component signal.

**HDTV-YPBPR:** Inputs the HDTV (YPBPR) signal.

**HDTV-GBR:** Inputs the HDTV(GBR) signal.

## INPUT B

Selects the signal input from the IFB-12 Signal Interface Board (not supplied) installed to the INPUT B section.

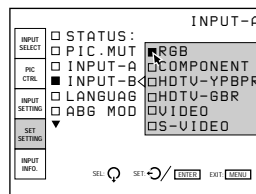

**RGB:** Inputs the RGB signal.

**COMPONENT:** Inputs the component signal.

**HDTV-YPBPR:** Inputs the HDTV (YPBPR) signal.

**HDTV-GBR:** Inputs the HDTV(GBR) signal.

**VIDEO:** Inputs the composite video signal.

**S-VIDEO:** Inputs the S video signal.

### Note

When a signal interface board other than the IFB-12 is installed, the menu items cannot be selected.

# Using the MENU

## LANGUAGE

Selects the language used in the on-screen displays.

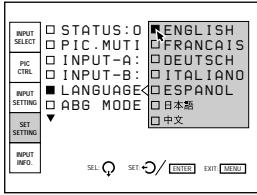

Available languages are: English, French, German, Italian, Spanish, Japanese and Chinese.

## ABG (Automatic Background) MODE

Normally, set to ON (factory setting). Cutoff luminance will be set to a certain level. Set to OFF if you want to erase the horizontal luminescent line for cutoff level detection that may appear at the upper part of the picture.

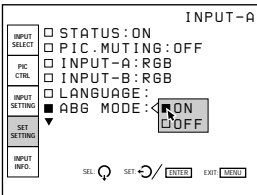

### Note

When ABG MODE is set to OFF, the black level of the white balance may change.

## SCREEN SEL (Select)

Selects the screen to be used.

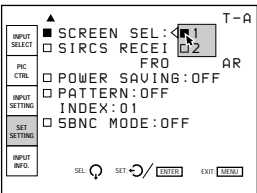

1: Bead screen

2: Mat screen

## SIRCS RECEIVER

Selects the remote control detectors on the front and rear of the projector, if the wireless remote control does not operate correctly due to the influence of a fluorescent lamp, etc.

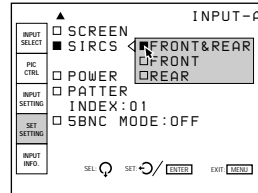

**FRONT & REAR:** Activates both the front and rear detectors.

**FRONT:** Activates the front detector only.

**REAR:** Activates the rear detector only.

## POWER SAVING

When set to ON, the projector goes into the power saving mode if no signal is input for 10 minutes. The screen enters cut-off mode. The power saving mode is canceled when a signal is input or whenever any key is pressed.

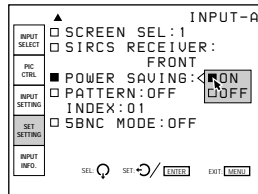

# Using the MENU

## PATTERN

Selects the type of the test pattern to be displayed.

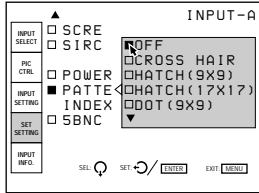

Selectable patterns are: CROSS HAIR, HATCH (9 × 9), HATCH (17 × 17), DOT (9 × 9), H, H INV (inverse), ME, ME INV (inverse), ALL WHITE, WINDOW, WINDOW&LINE and COLOR BAR (service adjustment mode).

Set to OFF when you do not want to display a test pattern.

For displaying the test patterns, see “Test Patterns” on page 61.

## INDEX (Index number)

Indicates the index number of the projector set with the INDEX NO. switches on the rear panel.

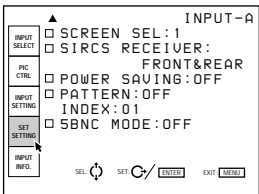

## 5BNC MODE

Set to ON when you connect the MONITOR OUT connector on the PC-1271/1271M Signal Interface Switcher (not supplied) to the INPUT A connectors with the 5BNC cables.

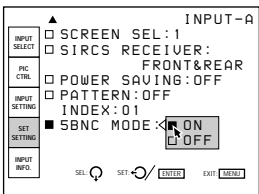

## The INPUT INFO (Information) Menu

The INPUT INFO menu displays the information on the current input signal.

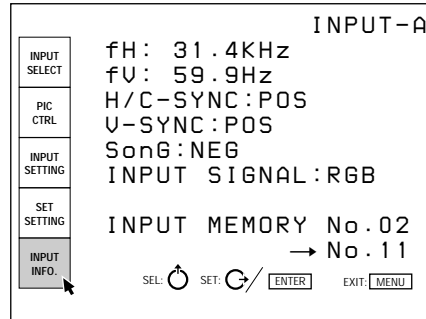

## fH (Horizontal frequency)

Indicates the horizontal frequency of the input signal. This indication is not an absolute value, but is only used as a reference.

## fV (Vertical frequency)

Indicates the vertical frequency of the input signal. This indication is not an absolute value, but is only used as a reference.

## H/C (Horizontal/Composite)-SYNC

Indicates the polarity of the horizontal or composite sync signal. When the picture is being projected using this type of sync signal, the POS (NEG) is displayed in green. When the picture is being projected without using this type of sync signal, the POS (NEG) is displayed in white.

**POS:** The polarity of the sync signal is positive.

**NEG:** The polarity of the sync signal is negative.

— — —: No sync signal is input.

# Using the MENU

## V (Vertical)-SYNC

Indicates the polarity of the vertical or composite sync signal.

When the picture is being projected using this type of sync signal, the POS (NEG) is displayed in green.

When the picture is being projected without using this type of sync signal, the POS (NEG) is displayed in white.

**POS:** The polarity of the sync signal is positive.

**NEG:** The polarity of the sync signal is negative.

-- -: No sync signal is input.

## SonG (Sync on Green)

Indicates the polarity of the sync on Green. When the picture is being projected using this type of sync signal, the NEG is displayed in green. When the picture is being projected without using this type of sync signal, the NEG is displayed in white.

**NEG:** The polarity of the sync signal is negative.

-- -: No sync signal is input.

## INPUT SIGNAL

Displays the type of current input signal.

**NTSC 3.58:** NTSC<sub>3.58</sub> input signal

**PAL:** PAL input signal

**SECAM:** SECAM input signal

**NTSC 4.43:** NTSC<sub>4.43</sub> input signal

**PAL-M:** PAL-M input signal

**B/W:** Black and white input signal

**Y/C:** S video input signal

**RGB:** RGB input signal

**COMPONENT:** Component input signal

**HDTV YPBPR:** HDTV YP<sub>B</sub>PR input signal

**HDTV GBR:** HDTV GBR input signal

**IDTV:** IDTV input signal from the optional PC-1271/1271M Signal Interface Switcher via the optional IFB-3000 Interface Board installed to the PC-1271/1271M.

## INPUT MEMORY No.

The upper number is the memory number of the data automatically loaded when the current signal is input. The lower number is the new memory number in which the adjustment data of the current input signal is stored. The existent memory number is displayed in green, and a new memory number in yellow.

For details, see "Memory structure" on page 107.

At the factory ten basic data are stored in the following memory numbers.

Memory number	Preset signal frequencies		Types of the input signal
	fH	fV	
00	15.7 kHz	60 Hz	Video (NTSC <sub>3.58</sub> )
01	24.8 kHz	56 Hz	RGB
02	31.5 kHz	60 Hz	RGB
03	48.3 kHz	60 Hz	RGB
04	64.0 kHz	60 Hz	RGB
05	75.0 kHz	60 Hz	RGB
06	93.7 kHz	75 Hz	RGB
07	106.3 kHz	85 Hz	RGB
08	31.5 kHz	60 Hz	IDTV (NTSC <sub>3.58</sub> )
09	33.8 kHz	60 Hz	HDTV (Y/P <sub>B</sub> /P <sub>R</sub> )

Data preset in memory numbers 00, 02 and 04 have been adjusted precisely at the factory.

Data in memory numbers 01, 03, 08 and 09 are processed by duplicating the data of 02, and those in memory numbers 05, 06 and 07 by duplicating the data of 04.

## FREQUENCY SENSITIVITY

Selects the sensitivity to the frequency deviation of the input signal, with which the INPUT MEMORY data is switched automatically. This item can be selected only for RGB input signals.

Press the  $\blacktriangleright$  key or the ENTER key on the INPUT INFO menu, and the INPUT MEM. OPTION menu appears. Press the  $\blacktriangleright$  key or the ENTER key again to show the frequency sensitivity options.

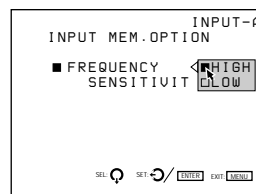

**HIGH:** This position is selected at the factory.

**LOW:** Set to this position if the input signal is unstable or flickers. This phenomenon may appear during variable speed playback by the VCR, etc.

### Note

If you press the  $\blacktriangleright$  key or the ENTER key on the INPUT INFO menu when the projector is in the expert mode, another INPUT MEM. OPTION menu is displayed.

For details, see "The INPUT MEM. (memory) OPTION Menu in Expert Mode" on page 57.

## The SERVICE SETTING Menu

The SERVICE SETTING menu is used for adjustments performed in service adjustment mode. “S” appears at the top left corner of the menu, indicating service adjustment mode.

### Page 1

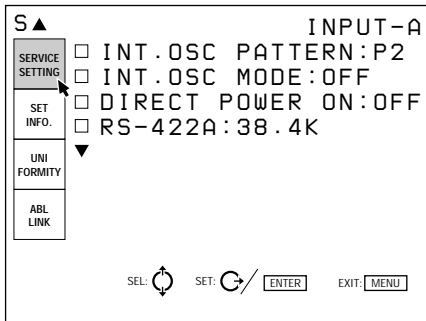

### Page 2

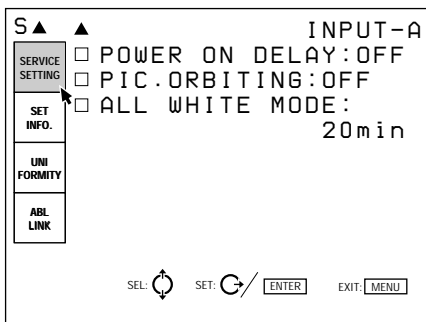

## INT. (Internal) OSC (Oscillation) PATTERN

Selects the oscillation frequency pattern generated with the internal oscillator. The horizontal and vertical frequencies for the selected pattern are displayed in the pop-up menu on the screen.

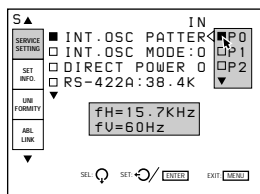

- P0:** fH = 15.7 kHz, fV = 60 Hz
- P1:** fH = 24.8 kHz, fV = 56 Hz
- P2:** fH = 31.5 kHz, fV = 60 Hz
- P3:** fH = 48.3 kHz, fV = 60 Hz
- P4:** fH = 64.0 kHz, fV = 60 Hz
- P5:** fH = 75.0 kHz, fV = 60 Hz
- P6:** fH = 93.7 kHz, fV = 75 Hz
- P7:** fH = 106.3 kHz, fV = 85 Hz

## INT. (internal) OSC. (ocillation) MODE

Set to ON to activate the internal oscillator.

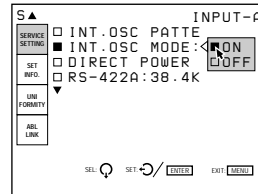

### Note

When no signal is input, you cannot select this item.

## DIRECT POWER ON

Set to ON to turn on the projector by pressing the MAIN POWER switch on the projector. Set to OFF to enter standby mode by pressing the MAIN POWER switch.

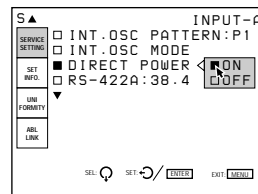

### Note

When the projector is in standby mode (it is turned off by pressing the POWER OFF key on the remote commander) with DIRECT POWER ON set to ON, the projector will be turned on automatically if the power interruption occurred and has been restored.

## RS-422A

Sets the communication baud rate for the RS-422A terminal to 38.4K, 19.2K, 9600 or 4800.

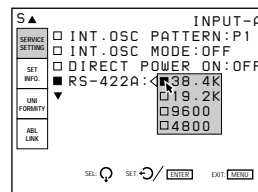

# Using the MENU

## POWER ON DELAY

When connecting multiple projectors, set to ON to turn on the projectors sequentially one by one.

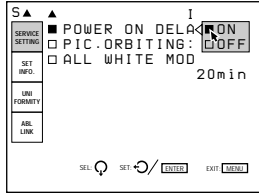

## PIC. (picture) ORBITING

Set to ON to activate the function which shifts the picture slightly to reduce CRT burn.

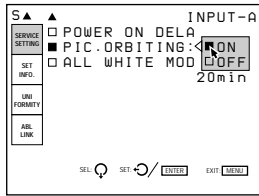

## ALL WHITE MODE

Sets the duration of all white mode during a warm-up period.

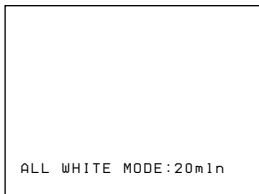

Use the **▲**, **▼**, **◀** or **▶** key to set the duration in 1 minute increments from 0 to 99 minutes. To set the projector to display the picture immediately after the projector is turned on, set the duration to “0 min.”  
*For details, see “Changing the Initialization Period” on page 113.*

## The SET INFO (information) Menu

The SET INFO menu displays the information on the projector such as the serial number, a ROM version, the use time of the projector.

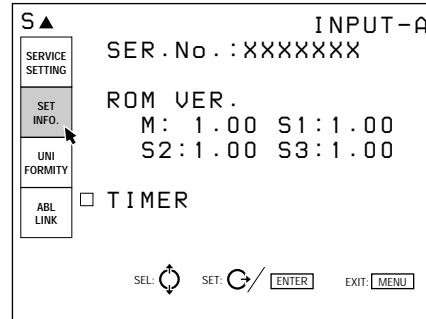

## SER. (serial) No.

Indicates the serial number of the projector.

## ROM VER. (version)

Indicates the ROM version (M, S1, S2 and S3) used for the projector.

## TIMER

Indicates the use time of the projector and that of each CRT.

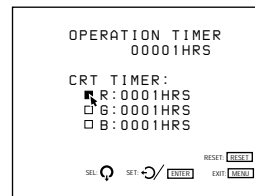

**OPERATION TIMER:** Indicates the total use time of the projector.

**CRT TIMER:** Indicates the use time of the red, green and blue CRTs, respectively.

## The UNIFORMITY Menu

The UNIFORMITY menu is used for making the picture color or brightness uniform.

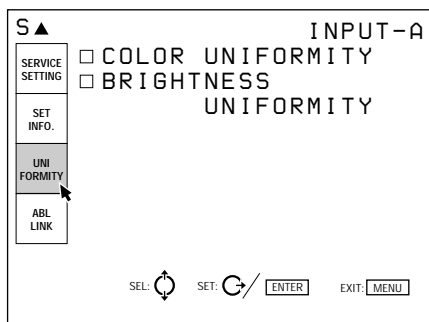

### COLOR UNIFORMITY

Corrects color shading to make the color of the whole screen uniform.

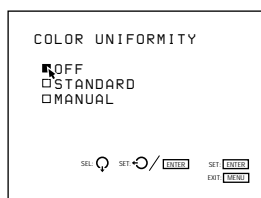

**OFF:** This position is selected at the factory.

**STANDARD:** Set to this position to obtain color uniformity which fits the screen selected in the SCREEN SEL option in the SET SETTING menu.

**MANUAL:** Set to this position to adjust color uniformity manually by displaying the external signal (all white).

When MANUAL is selected, the following display appears.

Select the adjustment item with the  $\downarrow$  key, then adjust the item with the  $\leftarrow$  or  $\rightarrow$  key.

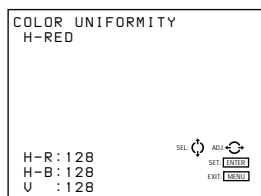

**H-R:** Adjusts red in the horizontal direction so that it becomes uniform.

**H-B:** Adjusts blue in the horizontal direction so that it becomes uniform.

**V:** Adjusts brightness in the vertical direction so that it becomes uniform.

Press the ENTER key after the adjustment is complete.

### BRIGHTNESS UNIFORMITY

Eliminates hot spots caused by the difference in brightness to make the brightness of the whole screen uniform.



**OFF:** This position is selected at the factory.

**STANDARD:** Set to this position to obtain brightness uniformity which fits the screen selected in the SCREEN SEL option in the SET SETTING menu.

**MANUAL:** Set to this position to adjust brightness uniformity manually by displaying the external signal (all white).

When MANUAL is selected, the following display appears.

Adjust the brightness in the horizontal direction with the  $\leftarrow$  or  $\rightarrow$  key and that in the vertical direction with the  $\uparrow$  or  $\downarrow$  key so that hot spots disappear from the screen.

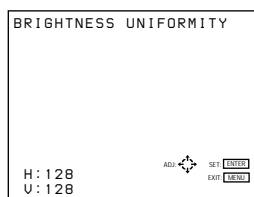

Press the ENTER key after the adjustment is complete.

# Using the MENU

## The ABL (Automatic Brightness Limiter) LINK Menu

The ABL LINK menu is used for adjusting to make the brightness of the multi-screen uniform when connecting multiple projectors.

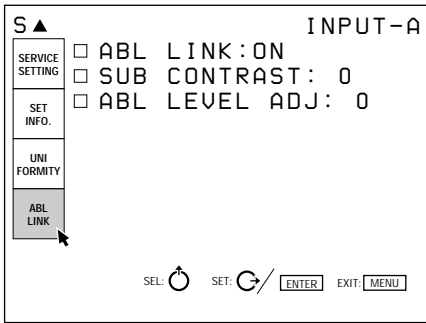

## ABL LEVEL ADJ (adjust)

When ABL LINK is set to ON, adjust the brightness of each projector so that the brightness of all projectors looks the same.

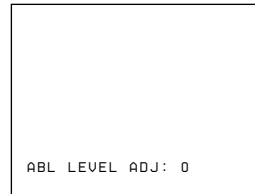

For details, see “Using the Linked ABL Function” on page 32.

## ABL LINK

When set to ON, the ABL (Automatic Brightness Limiter; to control the brightness of the picture when it is too high) functions on all projectors once the ABL functions on any projector.

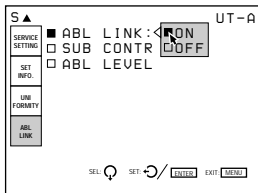

## SUB CONTRAST

When ABL LINK is set to ON, adjust the brightness of each projector so that the brightness of all projectors looks the same.



Before adjustment



## The OPTION Menu

The OPTION menu is used when installing the EXB-DS10 Extension Board to the projector.

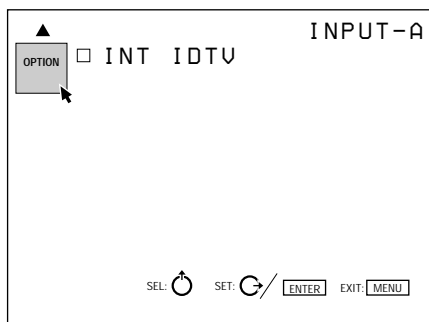

## INT. (internal) IDTV

Set to ON to project the video, S video, component or RGB (15 kHz) signal at double density.

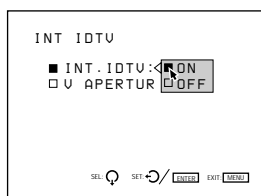

## V. (vertical) APERTURE

Corrects the sharpness in the vertical direction. You can set the sharpness to the LOW, MID (middle) or HIGH level.

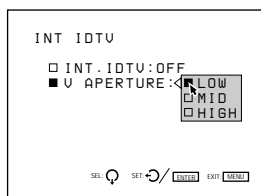

## The INPUT MEM. (memory) OPTION Menu in Expert Mode

This projector is provided with the INPUT MEM. OPTION menu especially for the expert service personnel who have specialized technology for and knowledge about the projector.

To display the INPUT MEM. OPTION menu in the expert mode, first enter into the expert mode. Then display the INPUT INFO menu and press the **▶** key or the ENTER key. The following INPUT MEM. OPTION menu appears on the screen.

To enter into the expert mode, see page 60.

### INPUT MEM. OPTION menu

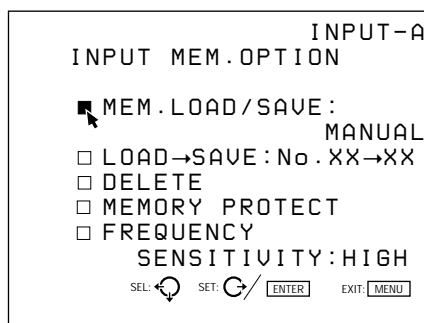

### Note

Normally, do not use the expert mode.

An inappropriate operation in this mode may impede the performance of the projector.

After adjustment, quickly exit from the expert mode.

# Using the MENU

## MEM. LOAD/SAVE

Specifies the input memory number to be loaded or saved.

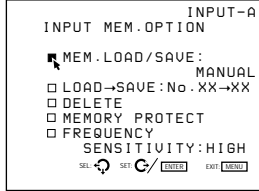

**AUTO:** Set to this position to select the input memory number to be loaded or saved automatically according to the type of input signal. This position is selected at the factory.

**MANUAL:** Set to this position to specify the input memory number to be loaded or saved. This position is useful when the loaded input memory number is unstable because there are two or more input signals whose frequencies are very similar, or when you want to assign a specified input memory number for the specified input source, or when you want to save the adjusted data to the specified input memory number.

When MANUAL is selected, “LOAD→SAVE” becomes selectable.

## LOAD→SAVE

Specifies the input memory numbers to be loaded and saved when MEM. LOAD/SAVE is set to MANUAL.

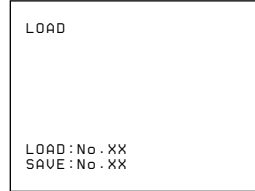

Press the ↓ or ↑ key to select LOAD or SAVE, and specify the desired input memory number with the ← or → key.

After specifying, press the ENTER key. The following display appears.

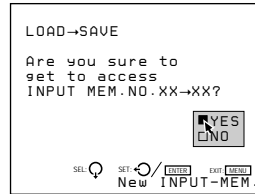

Press the ↓ or ↑ key to select YES, then press the ENTER key. The specified input memory numbers are stored in memory and the INPUT MEM. OPTION menu is resumed.

If you select NO, the specified numbers are canceled and the INPUT MEM. OPTION menu is resumed.

### Notes

- You cannot specify a non-existent memory number (displayed in yellow) as LOAD, or a memory-protected number (displayed in red) as SAVE.
- To load the specified memory number or save to that number, first exit the menu by pressing the MENU key.
- When MEM. LOAD/SAVE is set to MANUAL, the specified input memory numbers are effective even if the input signal or the input channel changes.

Before adjustment

## DELETE

Deletes an unnecessary input memory number.

Select DELETE in the INPUT MEM. OPTION menu and press the ENTER key. The INPUT MEM. DELETE display appears, and the currently selected input memory number is displayed. Press the ENTER key again. The following display appears.

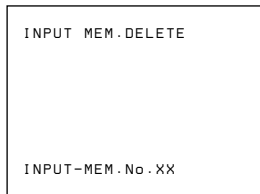

Specify the input memory number you want to delete with the ◀ or ▶ key.

After specifying, press the ENTER key. The following display appears.



Press the ▼ or ▲ key to select YES, then press the ENTER key. The specified input memory number is deleted from the memory and the INPUT MEM. DELETE display is resumed.

If you select NO, the specified number is canceled and the INPUT MEM. DELETE display is resumed.

### Notes

You cannot delete the following input memory numbers.

- Memory numbers 00 to 09 (to which data are preset at the factory)
- Memory-protected numbers (displayed in red)
- Non-existent memory numbers (displayed in yellow)
- Memory number specified as LOAD when MEM. LOAD/SAVE is set to MANUAL

## MEMORY PROTECT

Protects the data of a specified input memory number from overwriting or deleting.

Select MEMORY PROTECT in the INPUT MEM. OPTION menu and press the ENTER key. The MEMORY PROTECT display appears, and the currently selected input memory number is displayed. Press the ENTER key again. The following display appears.

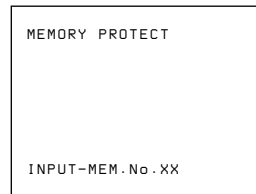

Specify the input memory number you want to protect with the ◀ or ▶ key.

After specifying, press the ENTER key. The following display appears.



Press the ▼ or ▲ key to select ON, then press the ENTER key. The data of the specified input memory number is protected and the MEMORY PROTECT display is resumed.

If you select OFF, the specified number is canceled and the MEMORY PROTECT display is resumed.

### Notes

- You can load the memory-protected input memory number and adjust the registration and picture quality, but cannot store the adjusted data.
- When performing the standard data saving after the registration adjustment (page 97), the data stored in the memory-protected numbers cannot be converted.
- The data stored in the memory-protected number cannot be reset.

# Using the MENU

## FREQUENCY SENSITIVITY

Selects the sensitivity to the frequency deviation of the input signal, with which the input memory data is switched automatically. This item can be selected only for RGB input signals.

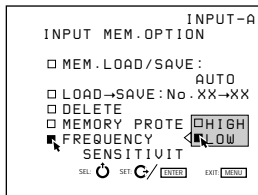

**HIGH:** This position is selected at the factory.

**LOW:** Set to this position if the input signal is unstable or flickers. This phenomenon may appear during variable speed playback by the VCR, etc.

## To set to the expert mode

- 1 Set the projector to the service mode.  
*For details, see "Preparation" on page 36.*
- 2 Press the NORMAL key.
- 3 Press the keys in the following order:  
ENTER → ENTER → ← → → → ENTER

Be sure to press the keys one after another within 2 seconds.

The following display appears.

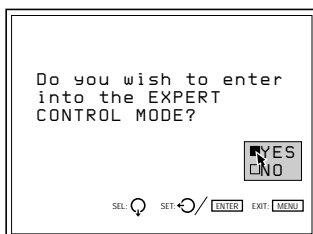

- 4 Press the ↓ or ↑ key to select YES, then press the ENTER key.  
If you select NO, the display disappears without changing the menu mode.
- 5 Press the MENU key.  
The menu in the expert mode appears with the letter "E" at the top-left of the screen.

## To exit from the expert mode

When you press the POWER OFF key after making adjustments in the expert mode, the projector is set to the standby mode and the menu mode is returned to the user mode automatically.

To reset to the service adjustment mode or the user mode before setting the projector to the standby mode, do the following:

- 1 Press the NORMAL key.
- 2 Press the keys in the following order.  
Be sure to press the keys one after another within 2 seconds.

## To reset to the service adjustment mode

Press the following keys in order:

ENTER → ENTER → ← → → → ENTER

The following display appears.

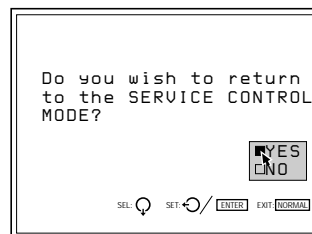

## To reset to the user mode

Press the following keys in order:

ENTER → ENTER → ↑ → ↓ → ENTER

The following display appears.

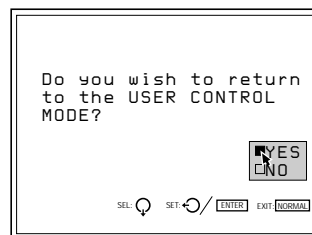

- 3 Press the ↓ or ↑ key to select YES, then press the ENTER key.  
The service adjustment mode or user mode is resumed.  
If you select NO the display disappears, leaving the expert mode.

# Test Patterns

## Test Patterns

In each adjustment mode, an appropriate test pattern appears. In addition, you can display other test patterns by pressing the PATTERN key.

1 CROSS HAIR

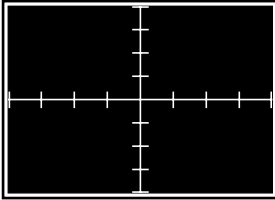

2 HATCH (9 x 9)

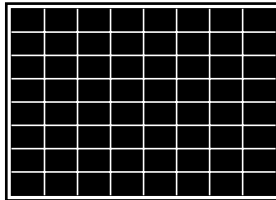

3 HATCH (17 x 17)

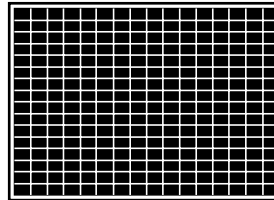

4 DOT (9 x 9)

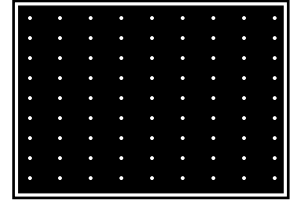

5 H

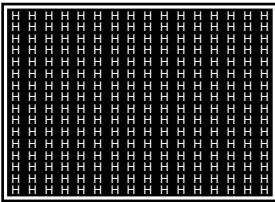

6 H INV (inverse)

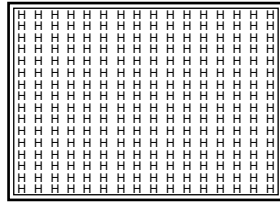

7 ME

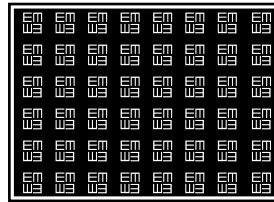

8 ME INV (inverse)

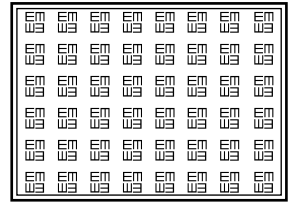

9 ALL WHITE

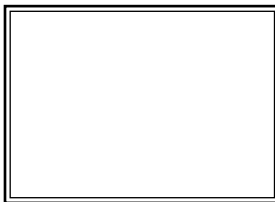

10 WINDOW

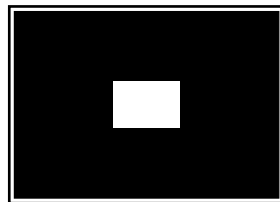

11 WINDOW & LINE

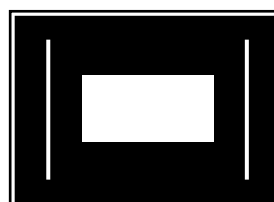

12 COLOR BAR

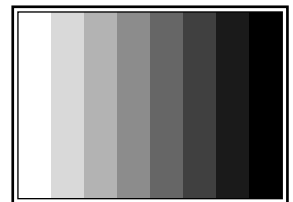

13 HATCH INV (invert) (17 x 17) (for adjusting registration only)

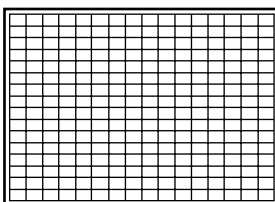

14 DOT (17 x 17) & HATCH (5 x 5) (for adjusting the magnetic focus and AQP/DQP only)

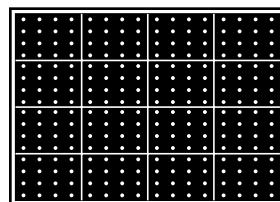

15 Sub-pattern 1 (subsidiary adjustment pattern 1) (for adjusting SIZE, LIN, SKEW and BOW only)

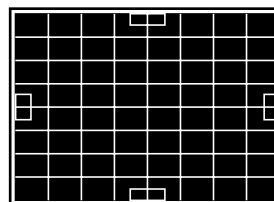

16 Sub-pattern 2 (subsidiary adjustment pattern 2) (for adjusting KEY and PIN only)

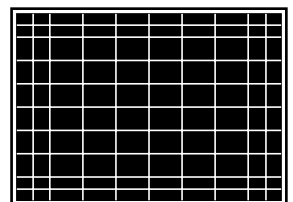

Before adjustment

# Test Patterns

17 CROSS (9 x 9)  
(for adjusting ZONE only)

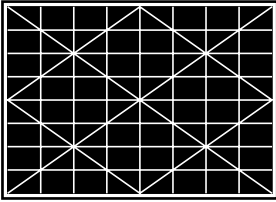

18 PLUGE (for adjusting BIAS only)



19 Stair step (for adjusting GAIN only)

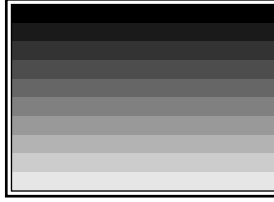

20 5 IRE  
(for adjusting BIAS only)



21 100 IRE  
(for adjusting GAIN and BIAS only)



Before adjustment

The patterns 1 to 12 appear in numerical order when pressing the PATTERN key in service adjustment mode.

The patterns 13 to 21 appear in specified adjustment modes only.

The outmost bold line of each pattern in the illustration stands for the edge of the screen.

## Test Patterns in Each Mode

The patterns cycle through the following order by pressing the PATTERN key.

Adjustment mode	Test pattern
CENT	CROSS HAIR → HATCH (9 × 9) → HATCH (17 × 17) → HATCH INV (17 × 17) → External signal / HATCH (17 × 17) → External signal → CROSS HAIR ...
SIZE LIN SKEW BOW	CROSS HAIR → Sub-pattern 1 → HATCH (17 × 17) → HATCH INV (17 × 17) → External signal / HATCH (17 × 17) → External signal → CROSS HAIR ...
KEY PIN KEY BALANCE PIN BALANCE	HATCH (9 × 9) → Sub-pattern 2 → HATCH (17 × 17) → HATCH INV (17 × 17) → External signal / HATCH (1 × 17) → External signal → HATCH (9 × 9) ...
ZONE	HATCH (9 × 9) → CROSS (9 × 9) → HATCH (17 × 17) → HATCH INV (17 × 17) → External signal / HATCH (9 × 9) → External signal → HATCH (9 × 9) ...
MG FOCUS AQP/DQP	DOT (9 × 9) → DOT (17 × 17) & HATCH (5 × 5) → ME → ME INV → ALL WHITE → External signal → DOT (9 × 9) ...
GAIN	Stair step → 100 IRE → WINDOW → External signal → Stair step ...
BIAS	PLUGE → 5 IRE → 100 IRE → External signal → PLUGE...
BLKG	External signal / HATCH (17 × 17) ↔ External signal
RGB SIZE RGB SHIFT	External signal ↔ External signal / HATCH (17 × 17)
Service adjustment mode	Test patterns ❶ to ❷ shown on page 61.
User adjustment mode	CROSS HAIR → HATCH (9 × 9) → ME → COLOR BAR → CROSS HAIR ...

# Adjustments

## Adjusting the Focus

### Focus Adjustment Procedure

#### Before starting the adjustments

- Make sure that the projector is installed correctly and the CRT conversion angle is adjusted correctly.
- When the picture is larger than the screen or is projected from the rear of the screen, roughly adjust the registration before proceeding to the focus adjustment.

#### Procedure

① Set the projector to the service adjustment mode. (page 37)



② Select the NO INPUT mode. (page 66)



③ Select the internal oscillation pattern (fH = 31.5 kHz). (page 66)



④ Display the H-pattern. (page 66)



⑤ Reset both CONTRAST and BRIGHT levels. (page 67)



⑥ Adjust the green lens focus. (page 67)



⑦ Open the upper cover and front cover. (pages 17 and 18)



⑧ Adjust flapping of the green lens. (page 68)



⑨ Adjust the green magnetic focus, AQP (Axis Quadrupole) and DQP (Diagonal Quadrupole). (page 70)

Repeat steps ⑥, ⑧ and ⑨ until the green signal is in focus.



(continued)



---

⑩ Adjust the red lens focus. *(page 72)*



⑪ Adjust flapping of the red lens. *(page 72)*



⑫ Adjust the red magnetic focus, AQP (Axis Quadrupole) and DQP (Diagonal Quadrupole). *(page 72)*

Repeat steps ⑩, ⑪ and ⑫ until the red signal is in focus.



⑬ Adjust the blue lens focus. *(page 73)*



⑭ Adjust flapping of the blue lens. *(page 73)*



⑮ Adjust the blue magnetic focus, AQP (Axis Quadrupole) and DQP (Diagonal Quadrupole). *(page 73)*

Repeat steps ⑬, ⑭ and ⑮ until the blue signal is in focus.



⑯ Adjust the uniformity of all-white mode screen. *(page 74)*



**Proceed to the registration adjustment.**



## Adjusting the Green Focus

### 1 Adjusting the green lens focus

- 1 Set the projector to the service adjustment mode.  
*For details, see "Preparation" on page 36.*
- 2 Press one of the INPUT SELECT keys on the remote commander corresponding to a line that is not connected to a signal.  
Or, set the SWITCHER/INDEX select switch to SWITCHER, and then press a number key from 1 to 8 corresponding to a line that is not connected to a signal.

"NO INPUT" appears on the screen.

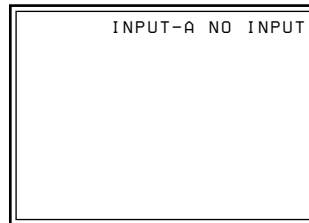

- 3 Display the SERVICE SETTING menu and set INT. OSC PATTERN to P2 (fH = 31.5 kHz).  
*For details, see "The SERVICE SETTING Menu" on page 53.*

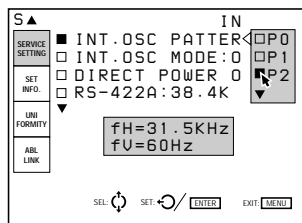

- 4 Reset the centering adjustment data of the green signal.  
*For details, see "Resetting the Data" on page 109.*
- 5 Press the NORMAL key on the remote commander to turn off the test pattern.
- 6 Press the PATTERN key on the remote commander until the H-pattern appears.

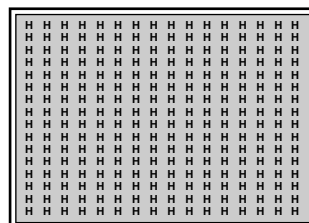

- 7** Reset the CONTRAST and BRIGHT levels.  
 The CONTR level resets to 80 by pressing the RESET key after pressing the PICTURE CONTROL CONTR key.  
 The BRIGHT level resets to 50 by pressing the RESET key after pressing the PICTURE CONTROL BRIGHT key.  
*For details, see “Adjusting the Picture Quality” on page 112.*

- 8** Press the CUT OFF R and B keys to display the green signal only.

- 9** Adjust the center-focus.  
 Loosen the G1 screw, slide it so that the letters H at the center of the screen are in focus, and then tighten the screw.

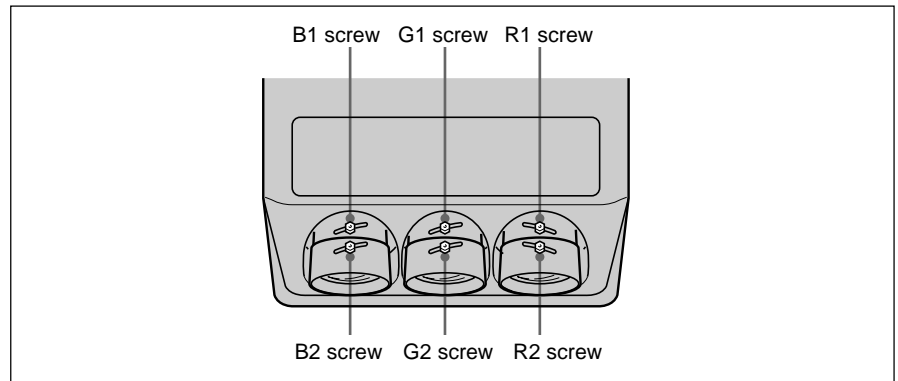

- 10** Adjust the corner-focus.  
 Loosen the G2 screw, slide it so that the letters H at all four corners of the screen (white areas illustrated below) are in focus, and then tighten the screw.  
 Repeat steps **9** and **10** until the green focus adjustment is completed.  
 (If the corner-focus cannot be adjusted completely, adjust it again after finishing the flapping adjustment of the green lens.)

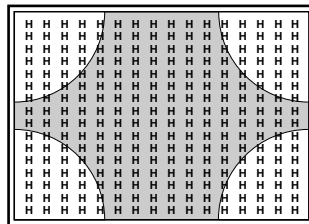

### Hint for the lens focus adjustment

The letter “H” is made up of dots. Adjust the focus so that dots of the letter “H” can be clearly seen as illustrated below.

Placing a white paper over the front of the screen will make it easier to see the dots.

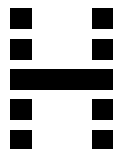

**Proceed to the adjustment for flapping of the green lens.**

# Adjusting the Focus

## 2 Adjusting flapping of the green lens

After finishing the lens focus adjustment, adjust flapping of the green lens (angle of the green CRT) so that the upper and lower parts, and the left and right parts of the screen are equally in focus.

- 1** Open the upper cover.  
*For how to open the upper cover, see page 17.*
- 2** Remove the front cover and the CRT fixing screws.  
*For how to remove the front cover, see page 18.*

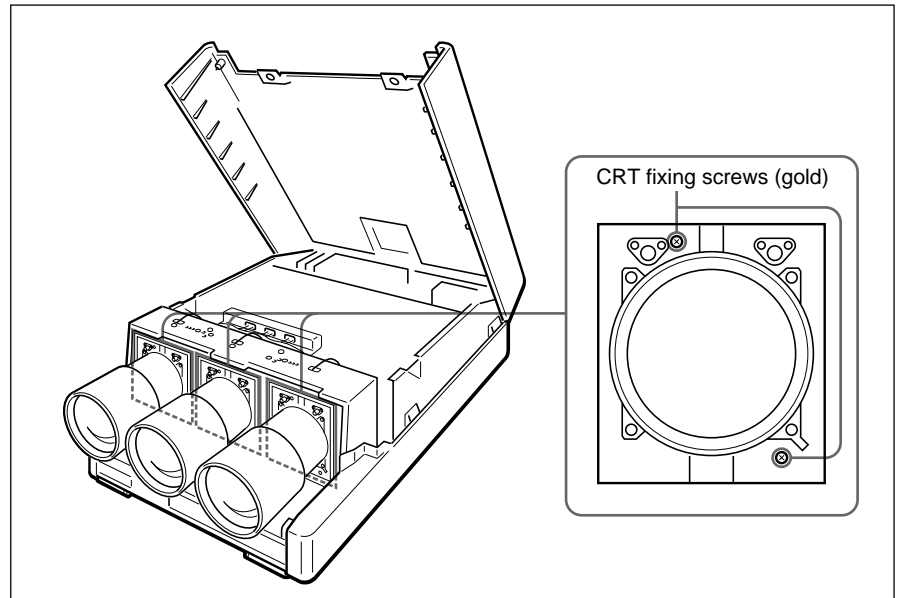

Each CRT is locked with two CRT fixing screws at the factory. When you adjust flapping for the first time, be sure to remove all six CRT fixing screws.

- 3** Place a white paper over the front of the screen. Note whether the focal surfaces on the upper, lower, left and right parts of the screen appear to be leaning forward or backward.

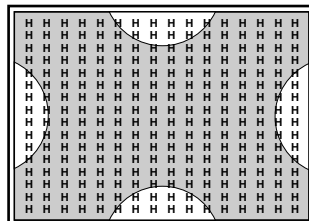

- 4** Adjust the focus on the upper and lower parts with the V screw on the green CRT using the supplied tool.

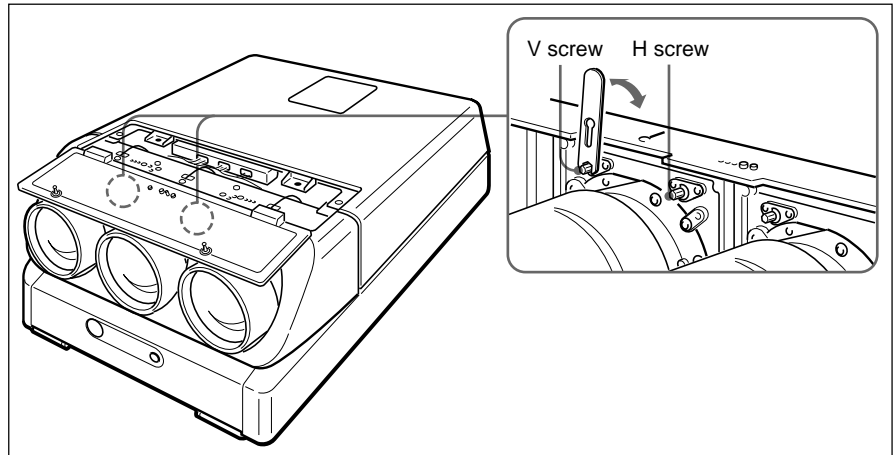

**Note**

Normally, adjust only the V screw for the green CRT. Adjusting the H screw is required only for non-standard installation. For flapping adjustments of the red and blue lenses, adjust both the H and V screws.

By turning the V screw, the CRT moves vertically to adjust the vertical tilt of the focal surface.

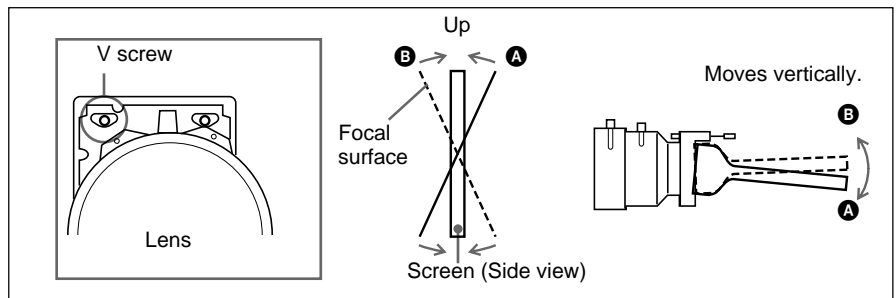

By turning the H screw, the CRT moves horizontally to adjust the horizontal tilt of the focal surface.

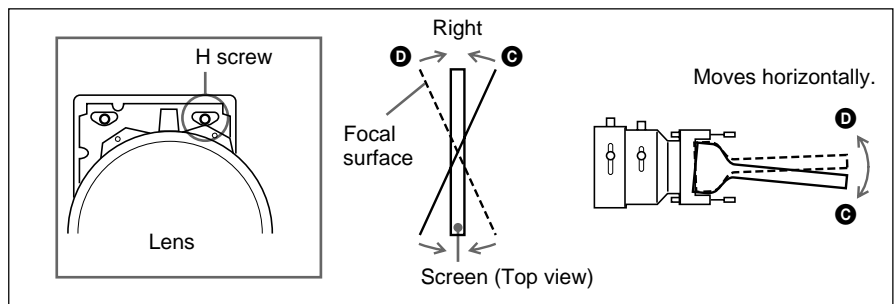

Repeat the above process until the upper and lower parts and the right and left parts of the screen are in focus.

**Proceed to the green magnetic focus and AQP/DQP adjustments.**

# Adjusting the Focus

## 3 Adjusting the green magnetic focus and AQP/DQP

After adjusting flapping of the lens, adjust the magnetic focus, AQP (Axis Quadrupole) and DQP (Diagonal Quadrupole).

### What is the AQP/DQP adjustment?

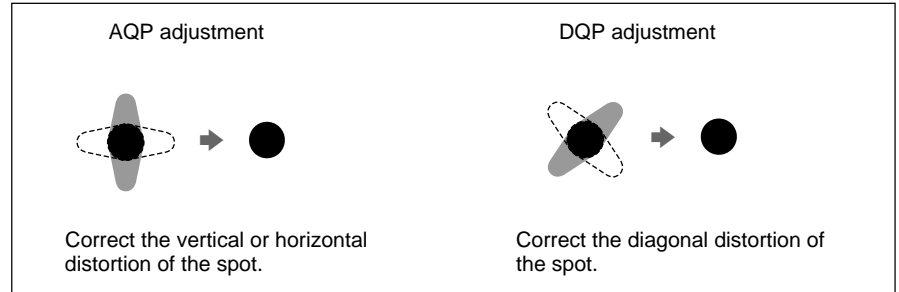

### 1 Press the MG FOCUS key.

The DOT pattern (9 × 9) appears on the screen, and a square for adjusting focus overlaps with the DOT pattern on the center of the screen.

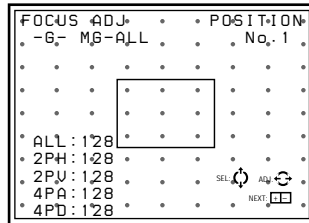

### 2 Adjust the focus at the center of the screen.

- ① Press the ◀ or ▶ key to set ALL to +40 so that flare appears on the screen.
- ② Press the ▲ or ▼ key to select 2PH, then press the ◀ or ▶ key so that the core of a spot is located at the horizontal center of the flare.
- ③ Press the ▲ or ▼ key to select 2PV, then press the ◀ or ▶ key so that the core of a spot is located at the vertical center of the flare.
- ④ Repeat steps ② and ③ so that the core of a spot is located at the center of the flare.
- ⑤ Press the ▲ or ▼ key to select ALL again, then set the value to -80 with the ◀ or ▶ key so that the spot is focused.
- ⑥ Press the ▲ or ▼ key to select 4PA, then correct the vertical and horizontal distortion of the spot with the ◀ or ▶ key.
- ⑦ Press the ▲ or ▼ key to select 4PD, then correct the diagonal distortion of the spot with the ◀ or ▶ key.

- ⑧ Repeat steps ⑥ and ⑦ so that the spot becomes a correct circle.
- ⑨ Press the PATTERN key until the ME INV (inverse) pattern is displayed.
- ⑩ Press the ▲ or ▼ key to select ALL and adjust so that the letters ME become as black as possible.

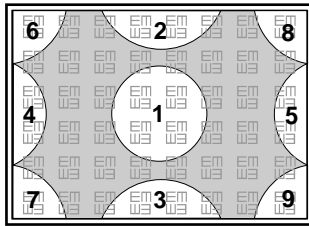
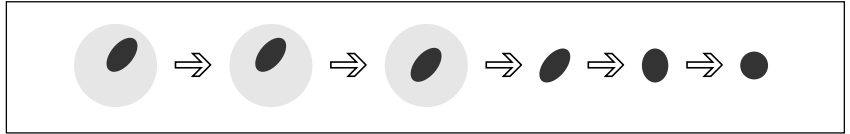

- 3** Press the POSITION + key once to enter the focus adjustment mode for the upper parts.

When you press the POSITION + key, the part to be adjusted cycles through the order as illustrated on the left. The position number is displayed at the upper right corner.

If you press the POSITION – key, the part cycles through the reverse order.

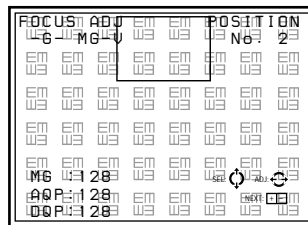

- 4** Adjust the focus and AQP/DQP for the upper part of the screen (white area 2 in the illustration on the left).

- ① Press the ◀ or ▶ key so that the upper part of the screen is in focus.
- ② Select AQP with the ▲ or ▼ key, and press the ◀ or ▶ key so that the letters ME become as black as possible (AQP adjustment).
- ③ Select DQP with the ▲ or ▼ key, and press the ◀ or ▶ key so that the letters ME become as black as possible (DQP adjustment).
- ④ Repeat steps ① to ③ so that the letters ME are focused best.

- 5** Perform the magnetic focus, AQP and DQP for every part of the screen (white areas 3 to 9 in the illustration) in numeric order.

- ① Press the POSITION + key to select the part to be adjusted.
- ② Press the ▲ or ▼ key to select the adjustment item.
- ③ Press the ◀ or ▶ key to adjust.

Repeat steps ② and ③ for each adjustment item.

**Proceed to adjust the red lens focus if the green magnetic focus, AQP and DQP are completed.**

**If the adjustments are not complete, repeat from the green lens focus again.**

## Adjusting the Red and Blue Focus

### 4 Adjusting the red lens focus

- 1** Reset the centering adjustment data of the red signal.  
*For details, see “Resetting the data” on page 109.*
- 2** Press the PATTERN key until the H-pattern is displayed.
- 3** Press the CUT OFF G and B keys to display the red signal only.
- 4** Loosen the R1 screw, slide it so that the letters H at the center of the screen are in focus, then tighten the screw.  
*For details, see “Adjusting the green lens focus” on page 66.*
- 5** Loosen the R2 screw, slide it so that the letters H at all four corners of the screen are in focus, then tighten the screw.  
Repeat steps **4** and **5** until the red focus adjustment is completed.

**Proceed to adjust flapping of the red lens.**

### 5 Adjusting flapping of the red lens

After adjusting the red lens focus, adjust flapping of the red lens (angle of the red CRT).

Check the tilt of the focal surfaces at the upper, lower, left and right parts of the screen, then adjust the focus with the H and V screws on the red CRT.

*For details, see “Adjusting flapping of the green lens” on page 68.*

**Proceed to adjust the red magnetic focus, AQP and DQP.**

### 6 Adjusting the red magnetic focus, AQP and DQP

After adjusting flapping of the red lens, adjust the magnetic focus, AQP and DQP. To adjust them, perform the same procedure as for the green magnetic focus, AQP and DQP.

*For details, see “Adjusting the green magnetic focus and AQP/DQP” on pages 70 and 71.*

Proceed to adjust the blue lens focus if every part of the screen for red signal is completely in focus.

#### **Note**

When the red magnetic focus adjustment mode is canceled, the red signal is slightly defocused. This is because the offset function activates so that the optimum picture is projected.

*For details on defocused level, see “Fine magnetic focus and AQP/DQP adjustments” on page 98.*



---

## 7 Adjusting the blue lens focus

- 1** Reset the centering adjustment data of the blue signal.  
*For details, see “Resetting the data” on page 109.*
- 2** Press the PATTERN key until the H-pattern is displayed.
- 3** Press the CUT OFF G and R keys to display the blue signal only.
- 4** Loosen the B1 screw, slide it so that the letters H at the center of the screen are in focus, then tighten the screw.  
*For details, see “Adjusting the green lens focus” on page 66.*
- 5** Loosen the B2 screw, slide it so that the letters H at all four corners of the screen are in focus, then tighten the screw.  
Repeat steps **4** and **5** until the blue focus adjustment is completed.

**Proceed to adjust flapping of the blue lens.**

---

## 8 Adjusting flapping of the blue lens

After adjusting the blue lens focus, adjust flapping of the blue lens (angle of the blue CRT).

Check the tilt of the focal surfaces at the upper, lower, left and right parts of the screen, then adjust the focus with the H and V screws on the blue CRT.

*For details, see “Adjusting flapping of the green lens” on page 68.*

**Proceed to adjust the blue magnetic focus, AQP and DQP.**

---

## 9 Adjusting the blue magnetic focus, AQP and DQP

After adjusting flapping of the blue lens, adjust the magnetic focus, AQP and DQP. To adjust them, perform the same procedure as for the green magnetic focus, AQP and DQP.

*For details, see “Adjusting the green magnetic focus and AQP/DQP” on pages 70 and 71.*

**If the blue signal is completely in focus, proceed to adjust the uniformity of all white mode screen.**

### Note

When the blue magnetic focus adjustment mode is canceled, the blue signal is slightly defocused. This is because the offset function activates so that the optimum picture is projected.

*For details on defocused level, see “Fine magnetic focus and AQP/DQP adjustments” on page 98.*

### **10** Adjusting the uniformity of all-white mode screen

After completing the green, red and blue focus adjustments, check the uniformity of all-white mode screen.

- 1** Press the MG FOCUS, B ADJ and MG FOCUS keys to enter the defocused mode.  
DEFOCUS is displayed on the screen and the blue signal is slightly defocused.  
*For details on defocused level, see “Fine magnetic focus and AQP/DQP adjustments” on page 98.*
- 2** Press the PATTERN key until the all-white screen appears.
- 3** If the all-white screen does not seem uniform, adjust the blue magnetic focus at the corners again so that the screen becomes uniform white.

**Proceed to adjust the registration if the uniformity of the all-white mode screen is adjusted completely.**

# Adjusting the Registration

## Procedure

- ① Mark the center of the screen. *(page 76)*  
↓
  - ② Set the projector to the service adjustment mode.  
*(page 37)*  
↓
  - ③ Select NO INPUT mode. *(page 76)*  
↓
  - ④ Select the internal oscillation pattern to be used for the registration adjustment. *(page 76)*  
↓
  - ⑤ Reset the registration data to the factory preset levels. (Only if the adjustment data has been modified before) *(page 109)*  
↓
  - ⑥ Adjust the green registration. *(pages 78 to 86)*
    - 1 CENT adjustment
    - 2 SIZE and LIN adjustments
    - 3 SKEW and BOW adjustments
    - 4 KEY and PIN adjustments
    - 5 KEY BALANCE and PIN BALANCE adjustments↓
  - ⑦ Adjust the red registration. *(pages 87 to 95)*
    - 1 CENT adjustment
    - 2 SIZE and LIN adjustments
    - 3 SKEW and BOW adjustments
    - 4 KEY and PIN adjustments
    - 5 KEY BALANCE and PIN BALANCE adjustments
    - 6 ZONE adjustment↓
  - ⑧ Adjust the blue registration. *(page 96)*
    - 1 CENT adjustment
    - 2 SIZE and LIN adjustments
    - 3 SKEW and BOW adjustments
    - 4 KEY and PIN adjustments
    - 5 KEY BALANCE and PIN BALANCE adjustments
    - 6 ZONE adjustment↓
  - ⑨ Save the adjusted data as the standard data. *(page 97)*  
↓
  - ⑩ Adjust fine for each input signal. *(pages 98 to 106)*
    - 1 Adjustment of video input signal
    - 2 Adjustment of RGB input signal
    - 3 White balance adjustment↓
  - ⑪ Reset to the user mode. *(page 111)*  
↓
  - ⑫ Adjust the picture. *(page 112)*  
↓
- Complete**

# Adjusting the Registration

## Preparation

- 1 Mark the center of the screen.  
Measure the height and width of the screen to determine the center.  
Marking five points with white tape, as illustrated below, will help you adjust registration.

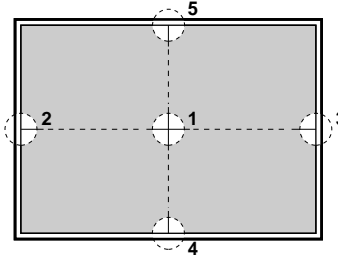

- 2 Set the projector to the service adjustment mode.  
*For details, see “For Remote Control” on page 36.*
- 3 Press one of the INPUT SELECT keys corresponding to a line that is not connected to a signal so that “NO INPUT” appears.  
Or, set the SWITCHER/INDEX select switch to SWITCHER and then press the number key from 1 to 8, corresponding to a line that is not connected to a signal.

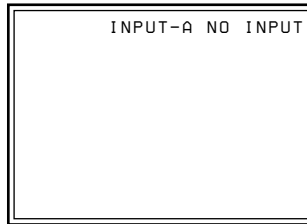

- 4 Display the SERVICE SETTING menu, select INT. OSC PATTERN, then select the frequency to be used for the adjustment.  
*For details, see “The SERVICE SETTING Menu” on page 53.*

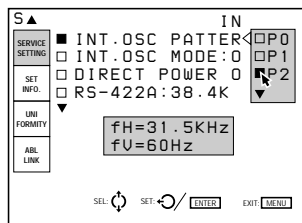

- 5 Reset the standard data to the factory preset level.  
(Only when you have adjusted the registration and have saved the adjustment data.)  
*For details, see “Resetting the Data” on page 109.*

### Notes

- The center of the screen and the center of the CROSS HAIR pattern can be aligned by performing the centering adjustment.  
*For details, see “Green CENT (centering) adjustment” on page 78.*
- When the optical axis angle is smaller, the HATCH pattern becomes trapezoidal. Perform the KEY (keystone) adjustment to correct the distortion.  
*For details, see “Green KEY and PIN adjustments” on page 83.*

## Keys for Adjusting

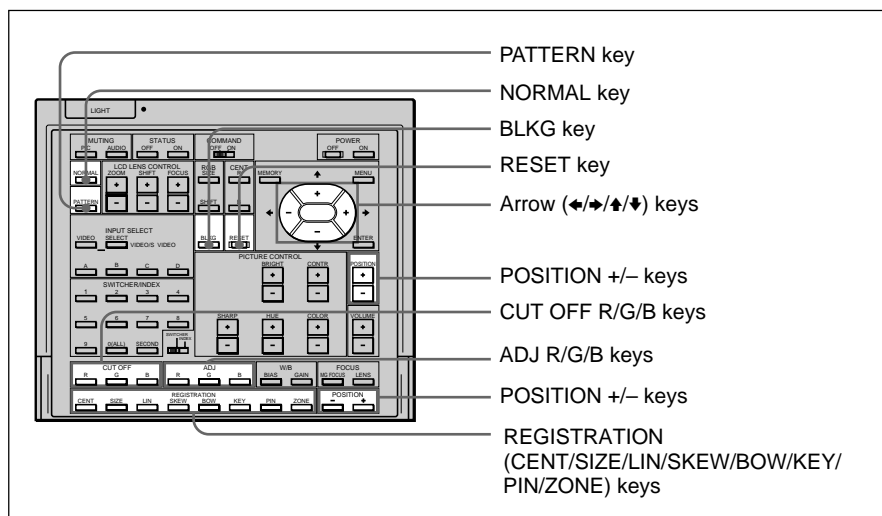

### Indications on the REGISTRATION keys and the adjustment items

Indicated on the control	Adjustment Items
CENT	Centering
SIZE	Size
LIN	Linearity
SKEW	Skew
BOW	Bow
KEY	Keystone, Keystone balance
PIN	Pincushion, Pincushion balance
ZONE	Zone

# Adjusting the Registration

## Adjusting the Green Registration

**Be sure to adjust the green registration first.**

When adjusting green, do not greatly change the ZONE adjustment. If you change the green ZONE in the large range considerably, the adjustment for red and blue may be difficult.

### 1 Green CENT (centering) adjustment

Adjust so that the center of the test pattern is aligned with the center of the screen.

- 1 Press the CENT key.  
The CROSS HAIR pattern and the cursor appear.
- 2 Press the ADJ G key.
- 3 Press the CUT OFF R and B keys to display green only.
- 4 Press the arrow keys to align the center of the CROSS HAIR pattern with the center of the screen.

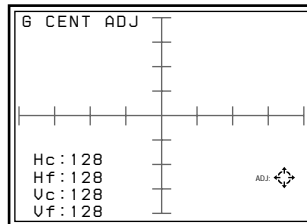

#### Notes

- If the test pattern is off-centered by a large amount, check if the projector is installed or adjusted correctly.
- If the upper, lower, left or right part of the screen is de-focused, check if flapping of the lenses is adjusted correctly.

*For details, see "Adjusting flapping of the green lens" on page 68.*

## 2 Green SIZE and LIN (linearity) adjustment

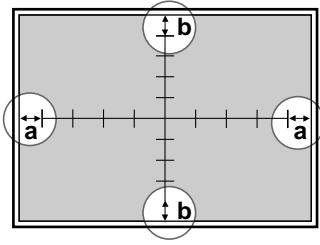

Adjust the picture size with respect to the screen, and the picture's up, down, left and right balance.

**1** Press the LIN key.  
The CROSS HAIR pattern appears.  
You can also change to the  $9 \times 9$  HATCH pattern by pressing the PATTERN key.

**2** Press the ADJ G key.  
Pay attention only to the encircled portions illustrated on the left.

**3** Adjust with the  $\leftarrow$  and  $\rightarrow$  keys until parts (a) (distances from the right and left ends of the screen to the first vertical lines) are of equal length.

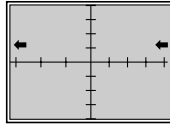

$\leftarrow$ : The left and right vertical lines are shifted to the left while the vertical center line remains unmoved.

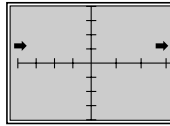

$\rightarrow$ : The left and right vertical lines are shifted to the right while the vertical center line remains unmoved.

**4** Press the SIZE key.

**5** Adjust with the  $\leftarrow$  and  $\rightarrow$  keys until parts (a) on the left and right are 15 to 20 mm long.

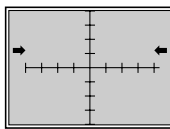

$\leftarrow$ : The horizontal scale is reduced.

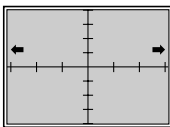

$\rightarrow$ : The horizontal scale is expanded.

**6** If they are not aligned, press the LIN key and repeat steps **3** to **5**.

**7** If the CROSS HAIR pattern is off-centered on the screen, adjust the centering again and repeat steps **1** to **6** for the horizontal scale adjustment.

*For details of the centering adjustment, see "Green CENT (centering adjustment)" on page 78.*

(continued)

## Adjusting the Registration

- 8** Press the LIN key.
- 9** Adjust with the  $\uparrow$  and  $\downarrow$  keys until parts (b) (distances from the top and bottom ends of the screen to the first horizontal lines) are of equal length.

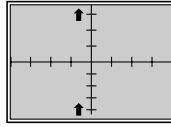

$\uparrow$ : The upper and lower horizontal lines are shifted upward while the horizontal center line remains unmoved.

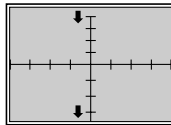

$\downarrow$ : The upper and lower horizontal lines are shifted downward while the horizontal center line remains unmoved.

- 10** Press the SIZE key.

- 11** Adjust with the  $\uparrow$  and  $\downarrow$  keys until parts (b) at the top and bottom are about 15 to 20 mm long.

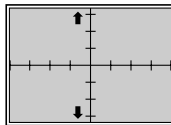

$\uparrow$ : The vertical scale is expanded.

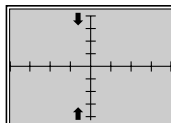

$\downarrow$ : The vertical scale is reduced.

- 12** If they are not aligned, repeat steps **8** to **11**.

- 13** If the CROSS HAIR pattern is off-centered on the screen, adjust the centering again and then repeat steps **8** to **12** for the vertical scale adjustment.

*For details of the centering adjustment, see “Green CENT (centering) adjustment” on page 78.*



### 3 Green SKEW and BOW adjustments

Adjust the bow-like or skew distortion of the horizontal and vertical center lines to make them parallel to the screen edges.

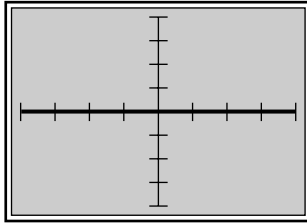

#### A Horizontal line adjustment

If the horizontal line of the picture is as shown by the dotted line in the illustrations below, adjust it with the corresponding arrow key so that it is perpendicular to the vertical line (bold line illustrated on the left).

- 1 Press the BOW key.  
The CROSS HAIR pattern appears.  
You can also change to the 9 × 9 HATCH pattern by pressing the PATTERN key.

- 2 Adjust the distortion as illustrated below with the  $\uparrow$  and  $\downarrow$  keys.

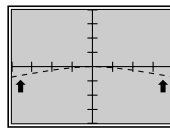

$\uparrow$  : The left and right ends of the horizontal line curve upward while the center remains unchanged.

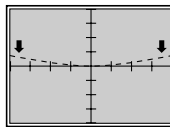

$\downarrow$  : The left and right ends of the horizontal line curve downward while the center remains unchanged.

- 3 Press the SKEW key.

- 4 Adjust the distortion as illustrated below with the  $\uparrow$  and  $\downarrow$  keys.

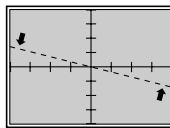

$\uparrow$  : The horizontal line rotates counter-clockwise, rotating around the center.

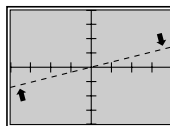

$\downarrow$  : The horizontal line rotates clockwise, rotating around the center.

- 5 Repeat steps 1 to 4 until the horizontal lines become parallel to the screen edges.

# Adjusting the Registration

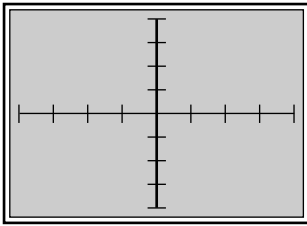

## **B** Vertical line adjustment

If the vertical line of the picture is as shown by the dotted line in the illustrations below, adjust it with the corresponding arrow key so that it is perpendicular to the horizontal line (bold line illustrated on the left).

- 1** Press the BOW key.  
The CROSS HAIR pattern appears.  
You can also change to the  $9 \times 9$  HATCH pattern by pressing the PATTERN key.

- 2** Adjust the distortion as illustrated below with the ◀ and ▶ keys.

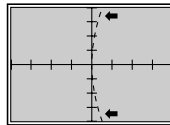

◀ : The upper and lower ends of the vertical line curve towards the left while the center remains unchanged.

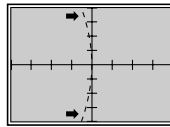

▶ : The upper and lower ends of the vertical line curve towards the right while the center remains unchanged.

- 3** Press the SKEW key.

- 4** Adjust the distortion as illustrated below with the ◀ and ▶ keys.

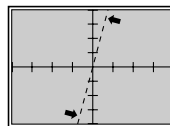

◀ : The vertical line rotates counter-clockwise, rotating around the center.

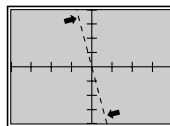

▶ : The vertical line rotates clockwise, rotating around the center.

- 5** Repeat steps **1** to **4** until the vertical lines become parallel to the screen edges.

## 4 Green KEY (keystone) and PIN (pincushion) adjustments

Adjust the trapezoidal distortion and the pin-cushion distortion in the vertical and horizontal directions.

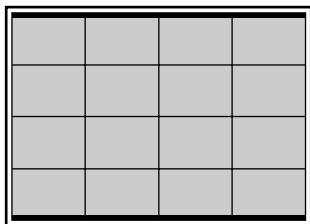

### A Horizontal line adjustment

If the picture's borders are as shown by the dotted line in the illustrations below, adjust them with the corresponding arrow key so that they are parallel (bold lines illustrated on the left).

- 1 Press the KEY key.  
The HATCH pattern appears.

- 2 Adjust the distortion as illustrated below with the **▲** and **▼** keys.

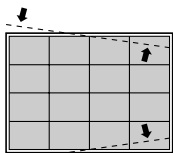

**▲** : The lines spread apart on the right side and come together on the left side while the center remains unmoved.

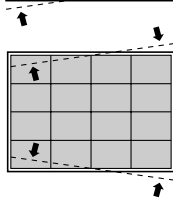

**▼** : The lines spread apart on the left side and come together on the right side while the center remains unmoved.

- 3 Press the PIN key.

- 4 Adjust the distortion as illustrated below with the **◀** and **▶** keys.

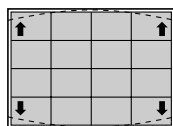

**◀** : The ends of the top and bottom lines spread apart while the center remains unmoved.

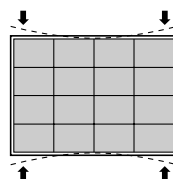

**▶** : The ends of the top and bottom lines come together while the center remains unmoved.

- 5 Repeat steps 1 to 4 until the horizontal lines become parallel to the screen edges.

# Adjusting the Registration

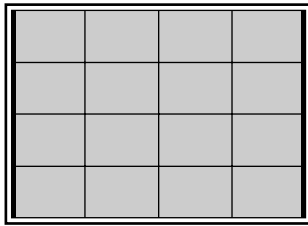

## **B** Vertical line adjustment

If the picture's borders are as shown by the dotted line in the illustrations below, adjust them with the corresponding arrow key so that they are parallel (bold lines illustrated on the left).

**1** Press the KEY key.  
The HATCH pattern appears.

**2** Adjust the distortion as illustrated below with the ◀ and ▶ keys.

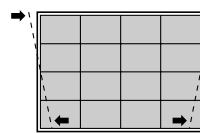

◀ : The lines spread apart at the bottom and come together at the top while the center remains unmoved.

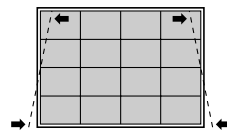

▶ : The lines spread apart at the top and come together at the bottom while the center remains unmoved.

**3** Press the PIN key.

**4** Adjust the distortion as illustrated below with the ◀ and ▶ keys.

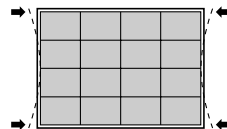

◀ : The ends of the left and right side lines come together while the center remains unmoved.

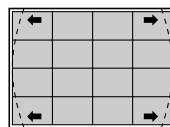

▶ : The ends of the left and right lines spread apart while the center remains unmoved.

**5** Repeat steps **1** to **4** until the vertical lines become parallel to the screen edges.

## 5 Green KEY (keystone) BALANCE and PIN (pincushion) BALANCE

Adjust the trapezoidal and pincushion distortion which may still remain even after completing the KEY and PIN adjustments.

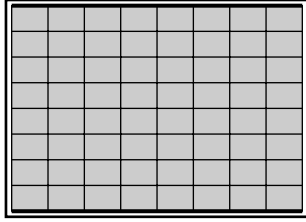

### A Horizontal line adjustment

If the picture's borders are as shown by the dotted line in the illustrations below, adjust them with the corresponding arrow key so that they are parallel (bold lines illustrated on the left).

- 1 Press the KEY key twice.  
The  $9 \times 9$  HATCH pattern appears.

- 2 Adjust the distortion as illustrated below with the  $\uparrow$  and  $\downarrow$  keys.

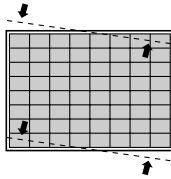

$\uparrow$  : The right ends of the lines are raised and the left ends are lowered while the center remains unmoved.

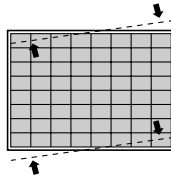

$\downarrow$  : The left ends of the lines are raised and the right ends are lowered while the center remains unmoved.

- 3 Press the PIN key twice.

- 4 Adjust the distortion as illustrated below with the  $\uparrow$  and  $\downarrow$  keys.

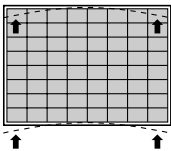

$\uparrow$  : The ends of the top and bottom lines curve upward while the center remains unmoved.

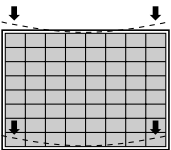

$\downarrow$  : The ends of the lines curve downward while the center remains unmoved.

- 5 Repeat steps 1 to 4 until the horizontal lines become parallel to the screen edges.

# Adjusting the Registration

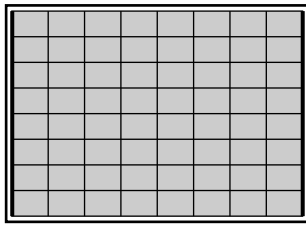

## **B** Vertical line adjustment

If the picture's borders are as shown by the dotted line in the illustrations below, adjust them with the corresponding arrow key so that they are parallel (bold lines illustrated on the left).

**1** Press the KEY key twice.  
The 9 × 9 HATCH pattern appears.

**2** Adjust the distortion as illustrated below with the ◀ and ▶ keys.

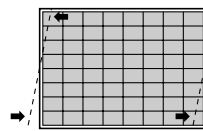

◀: The upper ends of the lines move towards the left and the lower ends move towards the right while the center remains unmoved.

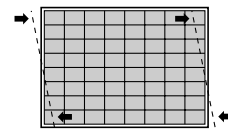

▶: The upper ends of the lines move towards the right and the lower ends move towards the left while the center remains unmoved.

**3** Press the PIN key twice.

**4** Adjust the distortion as illustrated below with the ◀ and ▶ keys.

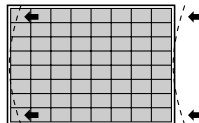

◀: The upper and lower ends of the lines curve towards the left while the center remains unmoved.

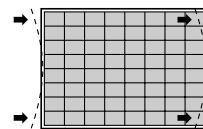

▶: The upper and lower ends of the lines curve towards the right while the center remains unmoved.

**5** Repeat steps **1** to **4** until the vertical lines become parallel to the screen edges.

**6** After the adjustment is complete, press the MEMORY key to save the adjustment data.

**The green registration adjustment is all completed.  
Proceed to the adjustment for the red signal.**

## Adjusting the Red Registration

Adjust the red signal so that it converges with the green signal and is seen as yellow.

### Note

When you have adjusted the red registration data and have saved the adjustment data, reset the red centering to the factory preset level.

*For the procedure to reset, see page 109.*

## 6 Red CENT (centering) adjustment

Adjust so that the center of the red CROSS HAIR pattern is aligned with that of the green CROSS HAIR pattern.

- 1 Press the CENT key.  
The CROSS HAIR pattern and the cursor appear.
- 2 Press the ADJ R key.
- 3 Press the CUT OFF B key to display green and red.
- 4 Press the arrow keys to align the center of the red CROSS HAIR pattern with that of the green pattern.

### Notes

- If the red vertical line is not aligned with that of the green pattern, adjust the red CRT conversion angle again.

*For details, see “Adjusting the CRT Conversion Angle” on page 21.*

- If the upper, lower, left or right part of the screen is de-focused, adjust flapping of the red lens again.

*For details, see “Adjusting flapping of the red lens” on page 72.*

## 7 Red SIZE and LIN (linearity) adjustments

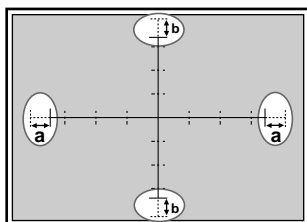

- 1 Press the LIN key.  
The CROSS HAIR pattern appears.  
You can also change to the 9 × 9 HATCH pattern by pressing the PATTERN key.
- 2 Press the ADJ R key.  
Pay attention only to the encircled portions in the illustration on the left.
- 3 Adjust with the ◀ and ▶ keys until the parts (a) on the left and right are of equal length.
  - ◀: The left and right vertical lines are shifted to the left while the vertical center line remains unmoved.
  - ▶: The left and right vertical lines are shifted to the right while the vertical center line remains unmoved.

*(continued)*

## Adjusting the Registration

---

- 4** Press the SIZE key.
- 5** Adjust with the ◀ and ▶ keys so that the red and green lines in the right and left encircled portions converge.
  - ◀: The horizontal scale is reduced.
  - ▶: The horizontal scale is expanded.
- 6** If the lines do not converge, press the LIN key and repeat steps **3** to **5**.
- 7** If the CROSS HAIR pattern is off-centered on the screen, adjust the centering again and repeat steps **1** to **6** for the horizontal scale adjustment.

*For details of the centering adjustment, see “Red CENT (centering) adjustment” on page 87.*
- 8** Press the LIN key.
- 9** Adjust with the ▲ and ▼ keys until parts ⑥ at the top and bottom are of equal length.
  - ▲: The upper and lower horizontal lines are shifted upward while the horizontal center line remains unmoved.
  - ▼: The upper and lower horizontal lines are shifted downward while the horizontal center line remains unmoved.
- 10** Press the SIZE key.
- 11** Adjust with the ▲ and ▼ keys so that the red and green lines at the top and bottom encircled portions converge.
  - ▲: The vertical scale is expanded.
  - ▼: The vertical scale is reduced.
- 12** If the lines do not converge, repeat steps **8** to **11**.
- 13** If the CROSS HAIR pattern is off-centered on the screen, adjust the centering again and repeat steps **8** to **12** for the vertical scale adjustment.

*For details of the centering adjustment, see “Red CENT (centering) adjustment” on page 87.*



## 8 Red SKEW and BOW adjustments

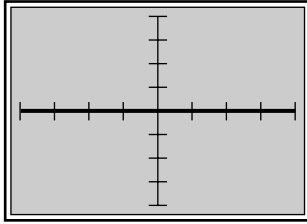

### A Horizontal line adjustment

If the horizontal line of the picture is as shown by the dotted line in the illustrations below, adjust it with the corresponding arrow key so that it is perpendicular to the vertical line (bold line illustrated on the left).

- 1 Press the BOW key.  
The CROSS HAIR pattern appears.  
You can also change to the  $9 \times 9$  HATCH pattern by pressing the PATTERN key.

- 2 Adjust the distortion as illustrated below with the  $\uparrow$  and  $\downarrow$  keys.

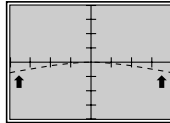

$\uparrow$  : The left and right ends of the horizontal line curve upward while the center remains unchanged.

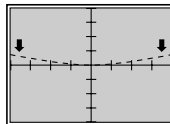

$\downarrow$  : The right and left ends of the horizontal line curve downward while the center remains unchanged.

- 3 Press the SKEW key.

- 4 Adjust the distortion as illustrated below with the  $\uparrow$  and  $\downarrow$  keys.

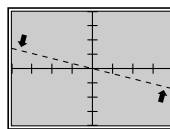

$\uparrow$  : The horizontal line rotates counter-clockwise, rotating around the center.

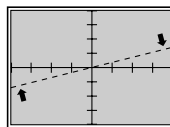

$\downarrow$  : The horizontal line rotates clockwise, rotating around the center.

- 5 Repeat steps 1 to 4 until the red horizontal line converges with the green line.

# Adjusting the Registration

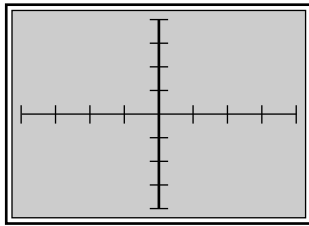

## B Vertical line adjustment

If the vertical line of the picture is as shown by the dotted line in the illustrations below, adjust it with the corresponding arrow key so that it is perpendicular to the vertical line (bold line illustrated on the left).

- 1 Press the BOW key.  
The CROSS HAIR pattern appears.  
You can also change to the  $9 \times 9$  HATCH pattern by pressing the PATTERN key.

- 2 Adjust the distortion as illustrated below with the ◀ and ▶ keys.

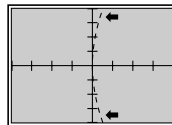

◀ : The upper and lower ends of the vertical line curve towards the left while the center remains unchanged.

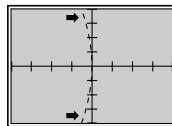

▶ : The upper and lower ends of the vertical line curve towards the right while the center remains unchanged.

- 3 Press the SKEW key.

- 4 Adjust the distortion as illustrated below with the ◀ and ▶ keys.

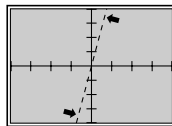

◀ : The vertical line rotates counter-clockwise, rotating around the center.

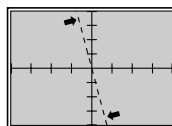

▶ : The vertical line rotates clockwise, rotating around the center.

- 5 Repeat steps 1 to 4 until the red vertical line converges with the green line.

## 9 Red KEY (keystone) and PIN (pincushion) adjustments

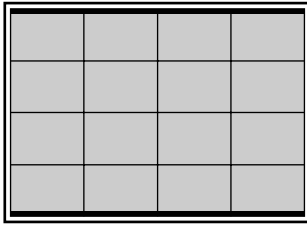

### A Horizontal line adjustment

If the picture's borders are as shown by the dotted line in the illustrations below, adjust them with the corresponding arrow key so that they are parallel (bold lines illustrated on the left).

**1** Press the KEY key.  
The HATCH pattern appears.

**2** Adjust the distortion as illustrated below with the **↑** and **↓** keys.

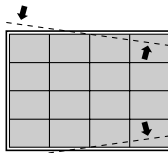

**↑** : The lines spread apart on the right side and come together on the left side while the center remains unmoved.

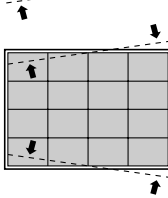

**↓** : The lines spread apart on the left side and come together on the right side while the center remains unmoved.

**3** Press the PIN key.

**4** Adjust the distortion as illustrated below with the **↑** and **↓** keys.

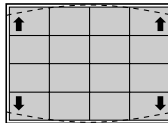

**↑** : The ends of the top and bottom lines spread apart while the center remains unmoved.

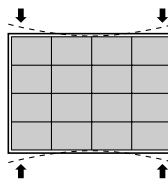

**↓** : The ends of the top and bottom lines come together while the center remains unmoved.

**5** Repeat steps **1** to **4** until the red horizontal lines converge with the green lines.

# Adjusting the Registration

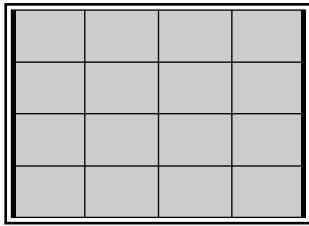

## **B** Vertical line adjustment

If the picture's borders are as shown by the dotted line in the illustrations below, adjust them with the corresponding arrow key so that they are parallel (bold lines illustrated on the left).

**1** Press the KEY key.  
The HATCH pattern appears.

**2** Adjust the distortion as illustrated below with the ◀ and ▶ keys.

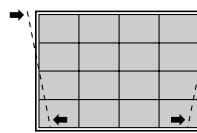

◀ : The lines spread apart at the bottom and come together at the top while the center remains unmoved.



▶ : The lines spread apart at the top and come together at the bottom while the center remains unmoved.

**3** Press the PIN key.

**4** Adjust distortion as illustrated below with the ◀ and ▶ keys.

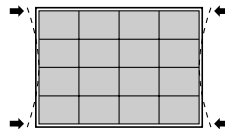

◀ : The ends of the left and right side lines come together while the center remains unmoved.

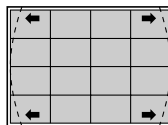

▶ : The ends of the left and right lines spread apart while the center remains unmoved.

**5** Repeat steps **1** to **4** until the red vertical lines converge with the green lines.

## 10 Red KEY (keystone) BALANCE and PIN (pincushion) BALANCE

Adjust the trapezoidal and pincushion distortion which may still remain even after completing the KEY and PIN adjustments.

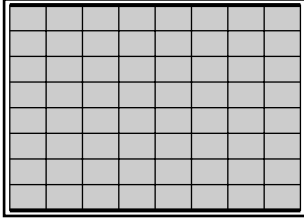

### A Horizontal line adjustment

If the picture's borders are as shown by the dotted line in the illustrations below, adjust them with the corresponding arrow key so that they are parallel (bold lines illustrated on the left).

- 1 Press the KEY key twice.  
The 9 × 9 HATCH pattern appears.

- 2 Adjust the distortion as illustrated below with the  $\uparrow$  and  $\downarrow$  keys.

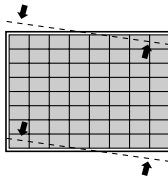

$\uparrow$  : The right ends of the lines are raised and the left ends are lowered while the center remains unmoved.

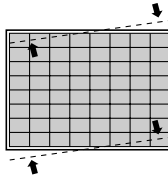

$\downarrow$  : The left ends of the lines are raised and the right ends are lowered while the center remains unmoved.

- 3 Press the PIN key twice.

- 4 Adjust the distortion as illustrated below with the  $\uparrow$  and  $\downarrow$  keys.

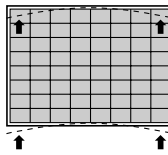

$\uparrow$  : The ends of the top and bottom lines curve upward while the center remains unmoved.

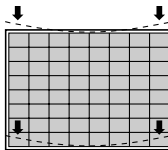

$\downarrow$  : The ends of the lines curve downward while the center remains unmoved.

- 5 Repeat steps 1 to 4 until the red horizontal lines converge with the green lines.

# Adjusting the Registration

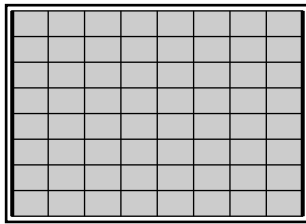

## B Vertical line adjustment

If the picture's borders are as shown by the dotted line in the illustrations below, adjust them with the corresponding arrow key so that they are parallel (bold lines illustrated on the left).

**1** Press the KEY key twice.  
The 9 × 9 HATCH pattern appears.

**2** Adjust the distortion as illustrated below with the ◀ and ▶ keys.

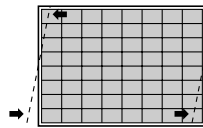

◀ : The upper ends of the lines move towards the left and the lower ends move towards the right while the center remains unmoved.

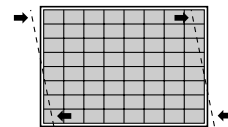

▶ : The upper ends of the lines move towards the right and the lower ends move towards the left while the center remains unmoved.

**3** Press the PIN key twice.

**4** Adjust the distortion as illustrated below with the ◀ and ▶ keys.

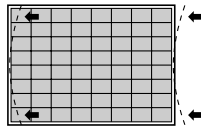

◀ : The upper and lower ends of the lines curve towards the left while the center remains unmoved.

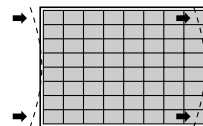

▶ : The upper and lower ends of the lines curve towards the right while the center remains unmoved.

**5** Repeat steps **1** to **4** until the red vertical lines converge with the green lines.

## 11 Red ZONE adjustment

Adjust red ZONE after the red lines have converged with the green lines by performing the adjustments **6** to **10**.

- 1 Press the ZONE key.  
The 9 × 9 HATCH pattern and the cursor appear.

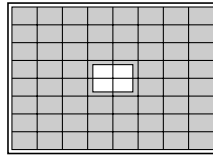

- 2 Press the POSITION +/- keys to select the part to be adjusted.  
When you press the + key, the cursor moves in the numerical order as illustrated.  
When you press the - key, the cursor moves in the reverse order.  
The selected position number appears at the upper right corner.

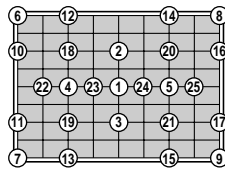

If you press the ZONE key again in ZONE adjustment mode, you can move the cursor to the desired position with the  $\uparrow, \downarrow, \leftarrow, \rightarrow$  keys. When you press the ZONE key again after selecting the position, the projector enters the adjustment mode of that position.

- 3 Adjust the red line distortion in the cursor positioning area with the arrow keys.
- 4 After the adjustment is complete, press the MEMORY key to save the adjustment data.

**The red registration adjustment is complete.  
Proceed to the registration adjustment of the blue signal.**

## Adjusting the Blue Registration

Adjust the blue signal so that it converges with the red signal which has been adjusted. When the blue and red test patterns converge, the pattern is seen as magenta.

### Note

When you have adjusted the blue registration data and have saved the adjustment data, reset the blue centering to the factory preset level.  
*For the procedure to reset, see page 109.*

## 12 Blue CENT (centering) adjustment

Adjust so that the center of the blue CROSS HAIR pattern is aligned with that of the red pattern.

- 1 Press the CENT key.  
The CROSS HAIR pattern and the cursor appear.
- 2 Press the ADJ B key.
- 3 Press the CUT OFF G key to display blue and red.
- 4 Press the arrow keys to align the center of the blue CROSS HAIR pattern with that of the red pattern.

### Notes

- If the blue vertical lines are not aligned with those of the red pattern, adjust the CRT conversion angle again.  
*For details, see “Adjusting the CRT Conversion Angle” on page 21.*
- If the upper, lower, left or right part of the screen is de-focused, adjust flapping of the lens again.  
*For details, see “Adjusting flapping of the blue lens” on page 73.*

## 13 Blue SIZE, LIN (linearity), SKEW, BOW, KEY (keystone), PIN (pincushion) KEY BALANCE, PIN BALANCE and ZONE adjustments

Adjust so that the blue signal converges with the red signal in each adjustment. The procedures are the same as for adjusting the red registration.

*For details, see pages 87 to 95.*

Make sure that “-- B” appears on the screen when adjusting the blue signal.



**The blue adjustment is complete. Save the adjustment data as the standard data.**



## Saving the Standard Registration Data

After adjusting all the registrations for the green, red and blue signals, save the adjustment data as the standard data for the projector.

- 1 Hold down the MEMORY key for more than 5 seconds in registration adjustment mode.

The adjustment data is saved in the memory as the data for the frequency selected in INT. OSC PATTERN of the SERVICE SETTING menu, and the projector enters the standard data saving mode.

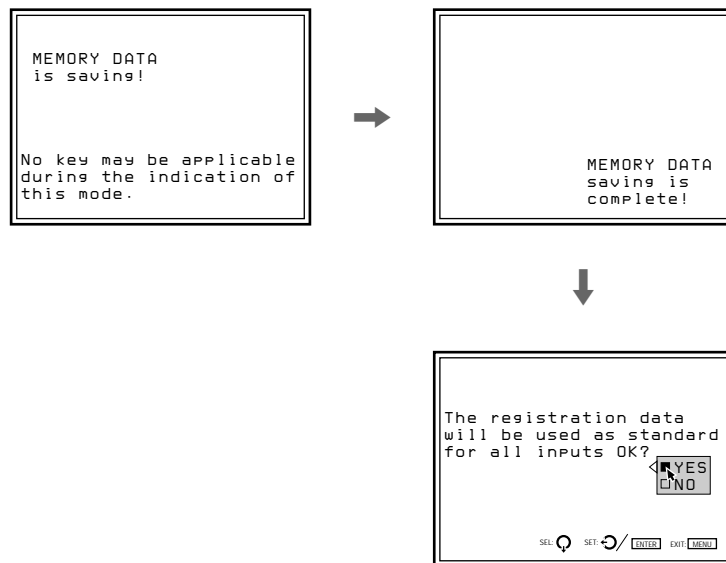

- 2 Press the  $\uparrow$  or  $\downarrow$  key to select YES, then press the ENTER key. All the registration data will be converted into internal signal data and are saved as standard data.

### Notes

- No keys function while the data is being saved.
- If the adjustment data is saved as the standard data, the registration data stored in INPUT MEMORY except those in memory-protected input memory numbers will be converted into the standard data.

# Fine Adjustment for Each Input Signal

After the registration adjustment is performed without an input source and the adjustment data is saved as the standard data, input an external signal and fine adjust for each input signal.

## Adjusting the Video Input Signal

The video signal can be connected via the optional IFB-1000 Signal Interface Board or the component inputs of the projector.

- 1** Connect a video signal to the signal interface board installed to the INPUT B section.
- 2** Select the video input source by pressing the INPUT SELECT B key on the remote commander.
- 3** Display the INPUT INFO menu and check that the horizontal frequency of the input signal (fH) indicates 15.7 kHz.  
To display the INPUT INFO menu, press the MENU key, select INPUT INFO with the ◀ or ▶ key, then press the ENTER key.
- 4** Adjust the magnetic focus and AQP/DQP for each input signal.  
*For details, see “Adjusting the green magnetic focus and AQP/DQP” on page 70.*

### Fine magnetic focus and AQP/DQP adjustments

- 1** Press the PATTERN key to display the 9 × 9 DOT pattern.
- 2** If necessary, fine adjust the magnetic focus, AQP and DQP.  
*For details, see “Adjusting the green magnetic focus and AQP/DQP” on page 70.*
- 3** Press the MEMORY key to save the adjustment data.

#### Note

Do not hold down the MEMORY key in step **3**.

#### Defocused level in magnetic focus adjustment mode

Optimized uniformity can be obtained by setting the magnetic focus “ALL” and the “4PA” adjustment levels to the defocused levels. The projector is designed to automatically defocus the red and blue “ALL” adjustment data. The defocused level varies with the color temperature and the horizontal frequency (fH) of the input signal. When the magnetic focus mode is canceled or the MG FOCUS key is pressed again during the magnetic focus adjustment, the defocused value listed in the tables on the next page is automatically added to the “ALL” adjustment level, and the magnetic focus “ALL” data is defocused. The “4PA” data, however, is not defocused automatically.

If you give priority to uniformity over spot focus, adjust “4PA” completely, then subtract the value in the table from the “4PA” adjustment level. If you give priority to spot focus over uniformity, adjust the magnetic focus “ALL” completely, then subtract the value in the table, which will be added to the data with automatic defocusing function, from the “ALL” adjustment level.

**Magnetic focus “ALL” when the color temperature is 9300K**

fH	15.7kHz	24.8kHz	31.5kHz	48.3kHz	64.0kHz	77.1kHz	93.7kHz	106.3kHz
Defocused value (R)	0	0	0	0	0	0	0	0
Defocused value (G)	0	0	0	0	0	0	0	0
Defocused value (B)	+30	+30	+15	+5	0	0	0	0

**Magnetic focus “ALL” when the color temperature is 6500K or 5400K**

fH	15.7kHz	24.8kHz	31.5kHz	48.3kHz	64.0kHz	77.1kHz	93.7kHz	106.3kHz
Defocused value (R)	+15	+15	+10	0	0	0	0	0
Defocused value (G)	0	0	0	0	0	0	0	0
Defocused value (B)	+30	+30	+15	+5	0	0	0	0

**Magnetic focus “ALL” when the color temperature is 3200K**

fH	15.7kHz	24.8kHz	31.5kHz	48.3kHz	64.0kHz	77.1kHz	93.7kHz	106.3kHz
Defocused value (R)	+15	+15	+10	0	0	0	0	0
Defocused value (G)	0	0	0	0	0	0	0	0
Defocused value (B)	0	0	0	0	0	0	0	0

**4PA**

fH	15.7kHz	24.8kHz	31.5kHz	48.3kHz	64.0kHz	77.1kHz	93.7kHz	106.3kHz
Defocused value (R)	0	0	0	0	0	0	0	0
Defocused value (G)	0	0	0	0	0	0	0	0
Defocused value (B)	-30	-30	-30	-30	0	0	0	0

**Example**

- Color temperature: 9300K, fH: 31.5 kHz
- Blue magnetic focus “ALL” adjustment level: 130
- Blue “4PA” adjustment level: 130

When you give priority to uniformity:

After correcting “4PA” completely, adjust “4PA” to the value arrived at by adding the value (-30) in the table from the “4PA” adjustment data.

$$4PA: 130 + (-30) = 100$$

When you give priority to spot focus:

After adjusting the magnetic focus “ALL” completely, adjust “ALL” to the value arrived at by subtracting the value (+15) in the table from the “ALL” adjustment data.

$$\text{Magnetic focus ALL: } 130 - (+15) = 115$$

## Fine Adjustment for Each Input Signal

### Fine registration adjustment

- 1 Press the PATTERN key to display the external signal with HATCH pattern.
- 2 If necessary, fine adjust the registrations.  
*For details of the adjustment procedure, see “Adjusting the Registration” on pages 75 to 96.*
- 3 Press the MEMORY key and release it to save the adjustment data.

#### Note

Do not hold down the MEMORY key in step 3.

### SIZE adjustment

Adjust the picture size if it does not fit the screen.

- 1 Press the RGB SIZE key.  
(Use the RGB SIZE key even for the signal other than RGB.)
- 2 Adjust the picture size with the arrow keys.
  - ↑ : The vertical size is expanded.
  - ↓ : The vertical size is reduced.
  - : The horizontal size is expanded.
  - ← : The horizontal size is reduced.

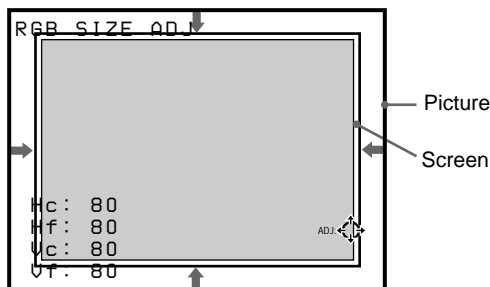

- 3 Press the MEMORY key to save the adjustment data.

### SHIFT adjustment

If the picture needs to be shifted to fit the screen, adjust the position of the picture.

- 1 Press the RGB SHIFT key.  
(Use the RGB SHIFT key even for the signal other than RGB.)

- 2 Adjust the shift with the arrow keys.
  - ▲ : The picture is shifted upward.
  - ▼ : The picture is shifted downward.
  - ▶ : The picture is shifted rightward.
  - ◀ : The picture is shifted leftward.

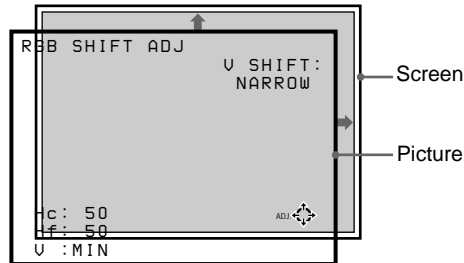

**Note**

When the video signal is input, V SHIFT is automatically fixed to NARROW and the adjustable range will become narrower than that of the RGB signal.

- 3 Press the MEMORY key to save the adjustment data.

## Blanking adjustment

If the displayed picture is larger than the screen, cut off the excess parts.

- 1 Press the BLKG key.
- 2 Press the POSITION +/- keys to select the part to be adjusted.
  - When you press the + key, the position cycles through the following order:  
TOP → BOTTOM → LEFT → RIGHT → TOP...
  - When you press the – key, the position cycles in reverse order.

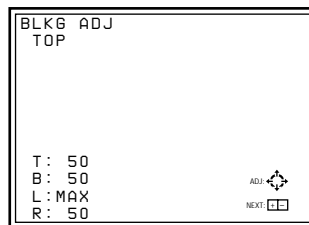

- 3 Adjust with the arrow keys.
  - Press the ▲ and ▼ keys to adjust the TOP and BOTTOM positions.
  - Press the ◀ and ▶ keys to adjust the LEFT and RIGHT positions.
- 4 Press the MEMORY key to save the adjustment data.

**Note**

When you connect multiple video input sources to the projector, such as when using the switcher, adjust the picture size, picture shift and blanking for each input connector.

## Fine Adjustment for Each Input Signal

---

### Adjusting the RGB Input Signal

- 1** Connect an RGB signal to the RGB IN connectors on the INPUT A or on the signal interface board installed to the INPUT B section.
- 2** Press the INPUT SELECT A or B key on the remote commander to select the RGB input signal.
- 3** Adjust the magnetic focus and AQP/DQP.  
*For details, see “Adjusting the green magnetic focus and AQP/DQP” on page 70.*
- 4** Fine adjust the registration if necessary.  
*For details, see “Adjusting the Registration” on pages 75 to 96.*

---

### Fine magnetic focus and AQP/DQP adjustments

- 1** Press the PATTERN key to display the  $9 \times 9$  DOT pattern.
- 2** If necessary, fine adjust the magnetic focus, AQP and DQP.  
*For details, see “Adjusting the green magnetic focus and AQP/DQP” on page 70.*
- 3** Press and release the MEMORY key to save the adjustment data.

---

### Fine registration adjustment

- 1** Press the PATTERN key to display the external signal with HATCH pattern.
- 2** If necessary, fine adjust the registration.  
*For details, see “Adjusting the Registration” on pages 75 to 96.*
- 3** When you connect two or more RGB input sources, fine adjust the registration for each input signal.
- 4** Press the MEMORY key and release it to save the adjustment data.

## SIZE adjustment

Adjust the picture size if it does not fit the screen.

- 1 Press the RGB SIZE key.
- 2 Adjust the picture size with the arrow keys.
  - ↑ : The vertical size is expanded.
  - ↓ : The vertical size is reduced.
  - : The horizontal size is expanded.
  - ← : The horizontal size is reduced.

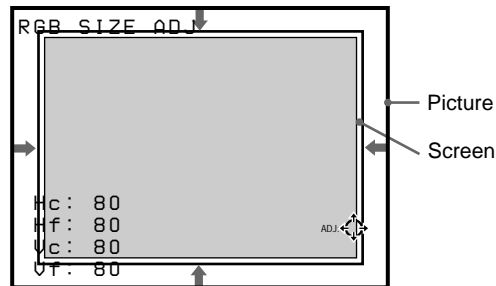

- 3 Press the MEMORY key to save the adjustment data.

## SHIFT adjustment

If the picture needs to be shifted to fit the screen, adjust the RGB SHIFT.

- 1 Press the RGB SHIFT key.
- 2 Select the adjustable range of the vertical shift (V SHIFT) with the POSITION +/- keys.
  - WIDE:** Normally, set to this position.
  - NARROW:** Set to this position to make the adjustable range in the vertical direction narrow.
- 3 Adjust the shift with the arrow keys.
  - ↑ : The picture is shifted upward.
  - ↓ : The picture is shifted downward.
  - : The picture is shifted rightward.
  - ← : The picture is shifted leftward.

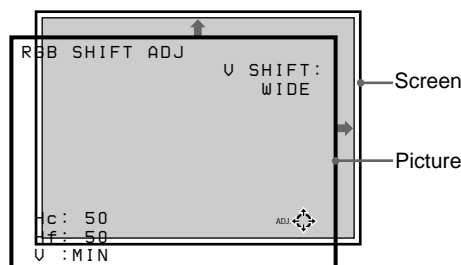

- 4 Press the MEMORY key to save the adjustment data.

# Fine Adjustment for Each Input Signal

## Blanking adjustment

If the displayed picture is larger than the screen, cut off the excess parts.

- 1** Press the BLKG key.
- 2** Press the POSITION +/- keys to select the part to be adjusted.
  - When you press the + key, the position cycles through the following order:  
TOP → BOTTOM → LEFT → RIGHT → TOP ...
  - When you press the – key, the position cycles in reverse order.

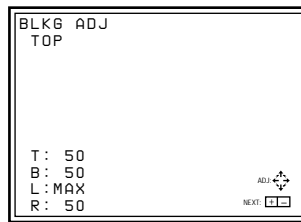

- 3** Adjust with the arrow keys.
  - Press the ▲ and ▼ keys to adjust the TOP and BOTTOM positions.
  - Press the ◀ and ▶ keys to adjust the LEFT and RIGHT positions.
- 4** Press the MEMORY key to save the adjustment data.

### Note

When you connect two or more RGB input sources to the projector, such as when using the switcher, adjust the picture size, picture shift and blanking for each RGB signal that has a different characteristic. The characteristics are shown in the INPUT INFO menu.



## Adjusting the White Balance

The color temperatures are preset at the factory to 9300K, 6500K, 5400K and 3200K. However, if you change these levels or set a color temperature other than the factory preset levels, you can adjust the white balance and save it in the memory.

### Setting the white balance

- 1 Press the MENU key, select INPUT SETTING with the  $\uparrow$  or  $\downarrow$  key, then press the ENTER key.  
The INPUT SETTING menu is displayed.
- 2 Press the  $\uparrow$  or  $\downarrow$  key to select COLOR TEMP, then press the ENTER key.
- 3 Press the  $\uparrow$  or  $\downarrow$  key to select the desired color temperature, then press the ENTER key.

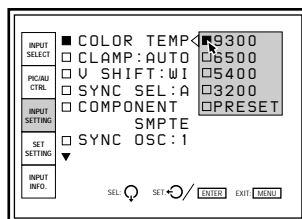

Normally set to 6500.

Select the appropriate color temperature according to your application and the picture source.

- 4 Press the MEMORY key to save the adjustment data.

### Adjusting the white balance

If you wish to make the color of a particular input signal (eg. HDTV system picture) uniform to that of the color monitor, you can adjust the white balance.

Display the same input signal on the projector and the monitor.

#### Adjusting the black level (BIAS adjustment)

- 1 Reset the CONTRAST level to 80 and BRIGHT level to 50.  
*For details, see "Adjusting the Picture Quality" on page 112.*
- 2 Press the W/B BIAS key.  
The PLUGE pattern appears. Press the PATTERN key repeatedly to display the external signal.
- 3 Press the ADJ R, G or B key to select the color to be adjusted.  
When selecting the color, pay attention to the black part of the picture displayed on the screen and note which color stands out compared to that of the monitor.

(continued)

## Fine Adjustment for Each Input Signal

- 4** Press the ◀ or ▶ key so that the black part in the picture on the screen looks the same as that of the monitor.  
If the brightness of that part does not look the same as that of the monitor, adjust the other colors by pressing the ADJ R, G or B key and the ◀ or ▶ key.
- 5** Press the MEMORY key to save the adjustment data.

### Adjusting the white level (GAIN adjustment)

- 1** Reset the CONTRAST level to 80 and BRIGHT level to 50.  
*For details, see “Adjusting the Picture Quality” on page 112.*
- 2** Press the W/B GAIN key.  
When the GAIN adjustment is followed by the BIAS adjustment, the external signal appears automatically.  
When you start with the GAIN adjustment, the stair step pattern appears. Press the PATTERN key repeatedly to display the external signal.
- 3** Press the ADJ R, G or B key to select the color to be adjusted.  
When selecting the color, pay attention to the white part of the picture displayed on the screen and note which color stands out compared to that of the monitor.
- 4** Press the ◀ or ▶ key so that the white part in the picture on the screen looks the same as that of the monitor.  
If the brightness does not look the same as that of the monitor, adjust the other colors by pressing the ADJ R, G or B key and the ◀ or ▶ key.
- 5** Press the MEMORY key to save the adjustment data.

### When using multiple projectors

Input the same signal to the base projector and the projector to be adjusted. Set COLOR TEMP in the INPUT SETTING menu to the same position on both projectors, and then follow the procedures described above to make the black and white colors uniform between the base projector and the projector to be adjusted.

#### Notes

- When adjusting the white balance, use the external color monitor for the reference of the color.
- To adjust the white balance easily without the on-screen display, press the STATUS OFF key on the remote control or set the STATUS option in the SET SETTING menu to OFF.
- You can adjust the white balance more easily if you set the color level to MIN to display the black and white picture.

# Saving the Adjustment Data

## Memory structure

The memory structure of this projector consists of three memory blocks and a normal adjustment data block.

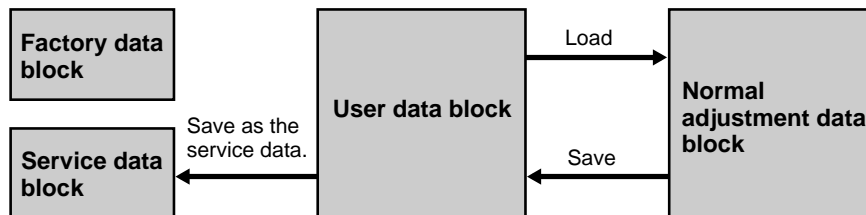

**Factory data block:** The ten basic adjustment data for different types of signals shown in the table on page 108 are preset at the factory. The adjustment data in this block cannot be changed.

**Service data block:** The ten basic adjustment data for different types of signals shown in the table on page 108 are preset at the factory. The data saved in the user data block can be saved as the service data.

**User data block:** The ten basic adjustment data for different types of signals shown in the table on page 108 are preset at the factory. When a new signal is input, the data that has the nearest frequency is automatically selected from among the ten basic data and the existing data saved as input memory and loaded. If any of the data for the signal is adjusted, the data is saved as an input memory in one of the memory numbers 00 to 99. (If no data is adjusted, it is not saved.) The adjustment data for each input signal, if any one of the signal input conditions—vertical or horizontal frequency, type of sync signal, type of input signal and input connector—is different, is saved in different memory number as an individual input memory. The memory number of the loaded data and that of the saved data are displayed as “INPUT MEMORY No.” on the INPUT INFO menu. If the same signal has already been input, the same memory number appears on two rows.

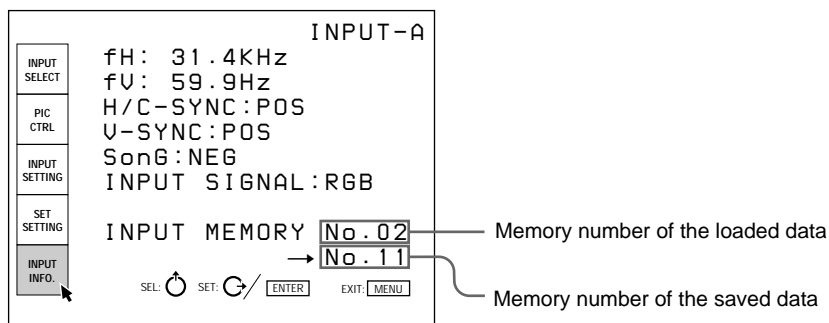

**Normal adjustment data block:** The data during adjustment is temporarily saved in this block. When you press the ENTER or MEMORY key after adjustment, the adjustment data is stored in the user data block.

# Saving the Adjustment Data

## Standard registration data and the input memory

If the adjusted registration data is saved as the standard data after installing the projector, the registration data for all of the input memories will be changed to reflect the new data in that installation condition. Therefore, you can easily adjust the registration for each input signal.

*For the procedure of how to save the standard data, see page 97.*

## Preset data at the factory

The projector presets ten types of basic data in memory numbers 00 to 09 of the factory data and service data blocks.

Memory number	Horizontal frequency (fH)	Vertical frequency (fV)	Type of the input signal
00	15.7 kHz	60 Hz	Video (NTSC <sub>3.58</sub> )
01	24.8 kHz	56 Hz	RGB
02	31.5 kHz	60 Hz	RGB
03	48.3 kHz	60 Hz	RGB
04	64.0 kHz	60 Hz	RGB
05	75.0 kHz	60 Hz	RGB
06	93.7 kHz	75 Hz	RGB
07	106.3 kHz	85 Hz	RGB
08	31.5 kHz	60 Hz	IDTV (NTSC <sub>3.58</sub> )
09	33.8 kHz	60 Hz	HDTV (Y/P <sub>B</sub> /P <sub>R</sub> )

Data preset in memory numbers 00, 02 and 04 have been adjusted precisely at the factory.

Data in memory numbers 01, 03, 08 and 09 are processed by duplicating the data of 02, and those in memory numbers 05, 06 and 07 by duplicating the data of 04.

## Memory architecture

The following adjustment data will be saved in three memory blocks.

Memory	Adjustment data	Number of memories
Input memory	Picture control (CONTRAST, BRIGHT, COLOR, HUE, SHARP) SIZE/SHIFT Blanking Color temperature Clamp position V SHIFT Registration Magnetic focus, AQP/DQP	Memory numbers 00–99 (100 at maximum)
Color temperature memory	White balance (BIAS/GAIN data for each color temperature of each screen)	Four color temperature settings (9300K/6500K/5400K/3200K)
Setting memory	Baud rate, CRT timer, STATUS ON/OFF, language, index, brightness/color uniformity, video memory	One for each projector

# Resetting the Data

There are three ways to reset the data, as shown below.

## Factory data reset

Resets to the factory preset data saved in the factory data block.

## Service data reset

Resets to the data saved in the service data block.

## 128 data reset (ZONE only)

Resets the ZONE adjustment data to 128.

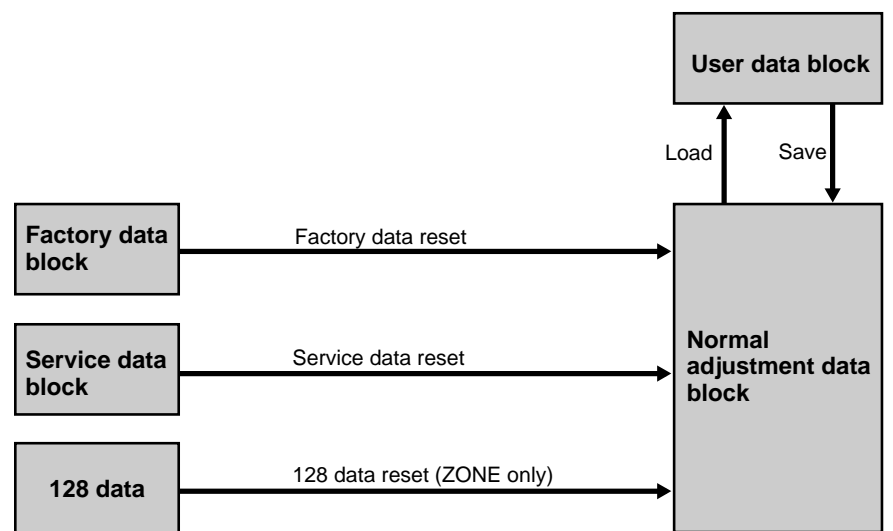

# Resetting the Data

## Resetting the data

- 1 Select the adjustment mode to be reset.
- 2 Press the RESET key.  
The following display appears. (Example: To reset the red registration data to the factory preset data)

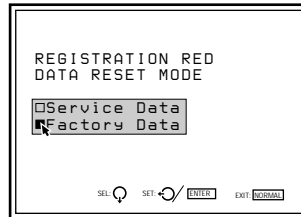

- 3 Press the  $\uparrow$  or  $\downarrow$  key to select the reset mode, then press the ENTER key.  
To cancel reset mode, press the NORMAL key.

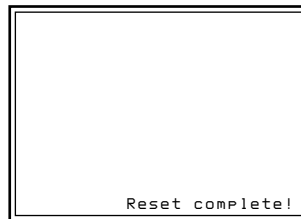

All red registration adjustment data will be reset to the factory preset data.

# Protecting the Setting

When you turn off the projector with the remote commander, the adjustment keys become inoperable in order to prevent users from accidentally changing the adjustments (user mode).

It is also possible to make the keys inoperable while the power is on in the following way.

- 1** Press the keys on the remote commander in the following order:  
ENTER → ENTER → ↑ → ↓ → ENTER  
The following display appears.

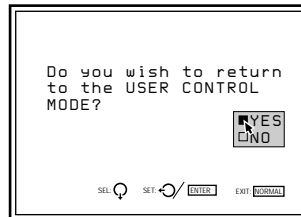

- 2** Press the ↑ or ↓ key to select “YES,” then press the ENTER key.

The adjustment keys on the remote commander become inoperable (user mode).

# Adjusting the Picture Quality

Adjust the picture for your preference. The adjustment data can be saved in the memory.

- 1 Adjust with the PICTURE CONTROL +/- keys.

BRIGHT	Brightness
CONTR	Picture contrast
COLOR	Color intensity
HUE	Hue
SHARP	Sharpness

The adjustment levels are digitally displayed with a range of MIN, 1, 2, ... 99, MAX.



- 2 Press the MEMORY key to save the data.

## Dynamic picture mode (only for the video or component input pictures)

You can get high quality picture contrast by setting D.PICTURE to ON in the PIC CTRL menu.

For details, see "The PIC CTRL (Picture Control) Menu" on page 45.

## Restoring the initial data

- 1 Press the PICTURE CONTROL key of the item which you want to reset to the initial data.
- 2 Press the RESET key.  
The selected item is reset to the initial data.

### Notes

- The COLOR, SHARP and HUE keys do not function on the pictures input from the RGB IN connectors.
- The HUE and COLOR keys do not function if the input signal is black and white.
- The HUE key does not function with the PAL or SECAM color input source.



# Others

## Changing the Initialization Period

You can set the desired warm up time for the projector in 1 minute increments.

- 1** Set the projector to the service adjustment mode.  
*For details, see “Preparation” on page 36.*
- 2** Press the MENU key, select SERVICE SETTING by pressing the ▲ or ▼ key, and press the ENTER key.  
The SERVICE SETTING menu appears.
- 3** Press the ▲ or ▼ key to select ALL WHITE MODE (Page 2), then press the ENTER key.

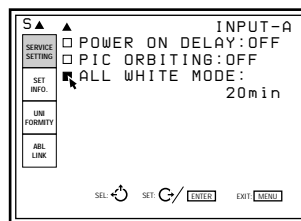

- 4** Press the ▲, ▼, ◀ or ▶ key to set the desired period.  
You can set it to 0–99 minutes.

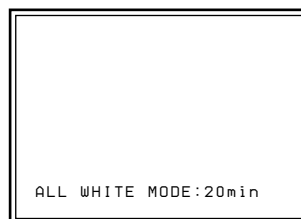

- 5** Press the MEMORY key to save the setting.

## Changing the Initialization Period

---

### **To cancel the setting**

Press the MENU key in step 3.

### **To set the projector so that the input signal from the connected equipment appears on the screen immediately after the power is turned on**

Set the initialization period to “0” in step 4.



# About Error Codes

When a critical operational error occurs, the power will be automatically turned off and the error code will light up on the error code window inside the projector. You can check the code without removing the cover. Refer to the chart below for the meanings.

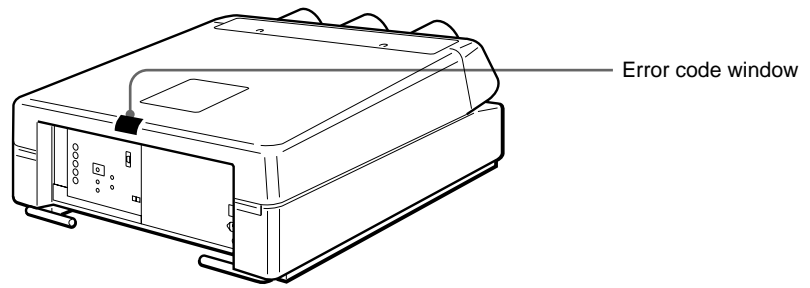

Error code	Item	Meaning
10	—	Abnormal input signal. Check the input signal.
20	Unknown	Abnormalities that do not come under the errors below.
21	POW1(115HV)	Abnormal in the 115 V (HV) line
22	POW2(115DEF)	Abnormal in the 115 V line
23	POW3(50)	Abnormal in the 50 V line
24	POW4(15)	Abnormal in the 15 V line
25	IFB	Abnormality of the interface board installed to the INPUT B section
26	LENS	A lens is removed.
27	POLARITY	The connector cover for polarity change does not shut completely.
29	B	Abnormality of the power line on the B board
30	DC	Abnormality of the power line on the DC board
31	EB	Abnormality of the power line on the EB board
32	EC	Abnormality of the power line on the EC board
33	HV	Abnormal high voltage
34	LOT	Abnormal load on a LOT of the PA board
35	H.STOP	Horizontal polarity is not correct.
36	V.STOP	Vertical polarity is not correct.
37	FAN	A fan inside the projector does not work.
38	CRT	Current in any of the R, G and B CRTs exceeds the rated output (detectable on the C board).
39	Ik	Current in any of the R, G and B CRTs exceeds the rated output (detectable on the B board).
40	$\Sigma$ Ik	There is abnormality in the CRTs.
88	CPU RESET	The CPUs on the YA, YB and YC boards are reset.

## Notes

- When the error code lights up, the previous adjustment data may be cleared.
- The error code disappears when the MAIN POWER switch is turned off and the power cord is disconnected.
- The error code lights up every time the power is turned on until the critical operational error is returned to normal.
- Immediately after the MAIN POWER switch is turned on, “88” is displayed for about one second. This is not a problem. The unit resets the CPUs to the initial status during this period.

# List of the Projection Distance by Angle of Optical Axis (for Flat Screen)

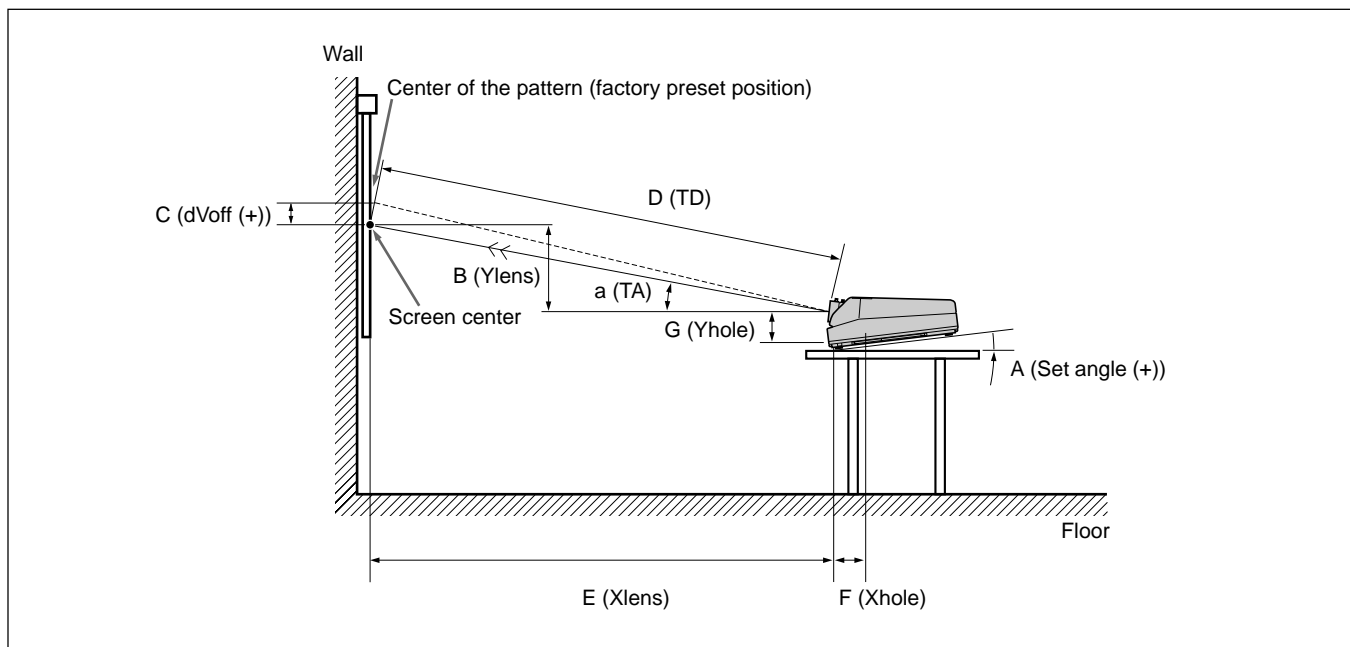

## When using the 60 inch screen

Unit: mm (inches) for **F** Xhole and **G** Yhole only

a TA (deg)	15.2°	14°	13°	12°	11°	10°	9°	8°	7°	6°	5°	4°	3°	2°	1°	0°	-1°	-2°
<b>B</b> / <b>E</b>	0.2718	0.2493	0.2309	0.2126	0.1944	0.1763	0.1584	0.1405	0.1228	0.1051	0.0875	0.0699	0.0524	0.0349	0.0174	0.0000	-0.0175	-0.0349
<b>A</b> Angle	0.0°	1.0°	1.8°	2.7°	3.5°	4.3°	5.2°	6.0°	6.8°	7.6°	8.6°	9.6°	10.6°	11.6°	12.6°	13.6°	14.6°	15.6°
<b>F</b> TD	220 (8 3/4)	225 (8 7/8)	228 (9)	232 (9 1/4)	235 (9 3/8)	239 (9 1/2)	242 (9 5/8)	246 (9 3/4)	249 (9 7/8)	252 (10)	256 (10 1/8)	260 (10 1/4)	264 (10 1/2)	267 (10 5/8)	271 (10 3/4)	274 (10 7/8)	278 (11)	281 (11 1/8)
<b>G</b> Yhole	257 (10 1/8)	253 (10)	250 (9 7/8)	246 (9 3/4)	243 (9 5/8)	239 (9 1/2)	236 (9 3/8)	232 (9 1/4)	229 (9 1/8)	225 (8 7/8)	221 (8 3/4)	216 (8 5/8)	212 (8 3/8)	207 (8 1/4)	203 (8)	198 (7 7/8)	193 (7 5/8)	188 (7 1/2)

## When using the 60 inch screen

Unit: mm (inches)

a TA (deg)	15.2°	14°	13°	12°	11°	10°	9°	8°	7°	6°	5°	4°	3°	2°	1°	0°	-1°	-2°
<b>E</b> Xlens	1668 (65 3/4)	1673 (65 7/8)	1678 (66 1/8)	1683 (66 3/8)	1687 (66 1/2)	1691 (66 5/8)	1694 (66 3/4)	1697 (66 7/8)	1700 (67)	1702 (67 1/8)	1704 (67 1/8)	1708 (67 1/4)	1719 (67 3/4)	1728 (68 1/8)	1737 (68 1/2)	1747 (68 7/8)	1753 (69 1/8)	1757 (69 1/4)
<b>B</b> Ylens	450 (17 3/4)	417 (16 1/2)	387 (15 1/4)	358 (14 1/8)	328 (13)	298 (11 3/4)	268 (10 5/8)	239 (9 1/2)	209 (8 1/4)	179 (7 1/8)	149 (5 7/8)	119 (4 3/4)	90 (3 5/8)	60 (2 3/8)	30 (1 3/16)	0 (0)	-31 (-1 1/4)	-61 (-2 1/2)
<b>D</b> TD	1727 (68)	1724 (67 7/8)	1722 (67 7/8)	1720 (67 3/4)	1718 (67 3/4)	1717 (67 5/8)	1715 (67 5/8)	1714 (67 1/2)	1713 (67 1/2)	1712 (67 1/2)	1711 (67 3/8)	1712 (67 1/2)	1721 (67 7/8)	1729 (68 1/8)	1737 (68 1/2)	1747 (68 7/8)	1754 (69 1/8)	1758 (69 1/4)
<b>C</b> dVoff	0 (0)	6 (1/4)	11 (7/16)	16 (21/32)	21 (27/32)	26 (1 1/16)	30 (1 3/16)	36 (1 7/16)	41 (1 5/8)	45 (1 13/16)	46 (1 13/16)	46 (1 13/16)	46 (1 13/16)	46 (1 13/16)	47 (1 7/8)	47 (1 7/8)	47 (1 7/8)	47 (1 7/8)

## When using the 70 inch screen

Unit: mm (inches)

a TA (deg)	15.2°	14°	13°	12°	11°	10°	9°	8°	7°	6°	5°	4°	3°	2°	1°	0°	-1°	-2°
<b>E</b> Xlens	1921 (75 3/4)	1927 (75 7/8)	1933 (76 1/8)	1938 (76 3/8)	1943 (76 1/2)	1947 (76 3/4)	1951 (76 7/8)	1955 (77)	1958 (77 1/8)	1961 (77 1/4)	1963 (77 3/8)	1967 (77 1/2)	1980 (78)	1991 (78 1/2)	2001 (78 7/8)	2012 (79 1/4)	2019 (79 1/2)	2024 (79 3/4)
<b>B</b> Ylens	519 (20 1/2)	481 (19)	446 (17 5/8)	412 (16 1/4)	378 (15)	343 (13 5/8)	309 (12 1/4)	275 (10 7/8)	240 (9 1/2)	206 (8 1/8)	172 (6 7/8)	138 (5 1/2)	104 (4 1/8)	70 (2 7/8)	35 (1 7/16)	0 (0)	-35 (-1 7/16)	-71 (-2 7/8)
<b>D</b> TD	1990 (78 3/8)	1986 (78 1/4)	1984 (78 1/8)	1982 (78 1/8)	1979 (78)	1977 (77 7/8)	1976 (77 7/8)	1974 (77 3/4)	1973 (77 3/4)	1971 (77 5/8)	1971 (77 5/8)	1972 (77 3/4)	1983 (78 1/8)	1992 (78 1/2)	2001 (78 7/8)	2012 (79 1/4)	2020 (79 5/8)	2025 (79 3/4)
<b>C</b> dVoff	0 (0)	7 (9/32)	13 (17/32)	19 (3/4)	24 (31/32)	30 (1 3/16)	36 (1 7/16)	42 (1 11/16)	47 (1 7/8)	53 (2 1/8)	54 (2 1/4)	54 (2 1/4)	54 (2 1/4)	54 (2 1/4)	54 (2 1/4)	54 (2 1/4)	54 (2 1/4)	55 (2 1/4)

**When using the 80 inch screen**

Unit: mm (inches)

a TA (deg)	15.2°	14°	13°	12°	11°	10°	9°	8°	7°	6°	5°	4°	3°	2°	1°	0°	-1°	-2°
<b>E</b> Xlens	2177 (85 3/4)	2185 (86 1/8)	2191 (86 3/8)	2197 (86 1/2)	2203 (86 3/4)	2207 (87)	2212 (87 1/8)	2216 (87 1/4)	2219 (87 3/8)	2222 (87 1/2)	2225 (87 5/8)	2230 (87 7/8)	2244 (88 3/8)	2257 (88 7/8)	2268 (89 3/8)	2281 (89 7/8)	2289 (90 1/8)	2294 (90 3/8)
<b>B</b> Ylens	590 (23 1/4)	545 (21 1/2)	506 (20)	467 (18 1/2)	428 (16 7/8)	389 (15 3/8)	350 (13 7/8)	311 (12 1/4)	273 (10 3/4)	234 (9 1/4)	195 (7 3/4)	156 (6 1/4)	118 (4 3/4)	79 (3 1/8)	40 (1 5/8)	0 (0)	-40 (-1 5/8)	-80 (-3 1/4)
<b>D</b> TD	2256 (88 7/8)	2252 (88 3/4)	2249 (88 5/8)	2246 (88 1/2)	2244 (88 3/8)	2242 (88 3/8)	2240 (88 1/4)	2238 (88 1/8)	2236 (88 1/8)	2235 (88)	2234 (88)	2235 (88)	2248 (88 5/8)	2258 (89)	2268 (89 3/8)	2281 (89 7/8)	2289 (90 1/8)	2295 (90 3/8)
<b>C</b> dVoff	0 (0)	8 (1 1/32)	15 (1 9/32)	21 (2 7/32)	28 (1 1/8)	34 (1 3/8)	41 (1 5/8)	48 (1 15/16)	54 (2 1/4)	61 (2 1/2)	61 (2 1/2)	61 (2 1/2)	61 (2 1/2)	62 (2 1/2)	62 (2 1/2)	62 (2 1/2)	62 (2 1/2)	62 (2 1/2)

**When using the 90 inch screen**

Unit: mm (inches)

a TA (deg)	15.2°	14°	13°	12°	11°	10°	9°	8°	7°	6°	5°	4°	3°	2°	1°	0°	-1°	-2°
<b>E</b> Xlens	2434 (95 7/8)	2442 (96 1/4)	2450 (96 1/2)	2456 (96 3/4)	2462 (97)	2468 (97 1/4)	2473 (97 3/8)	2477 (97 5/8)	2481 (97 3/4)	2484 (97 7/8)	2488 (98)	2492 (98 1/8)	2509 (98 7/8)	2522 (99 3/8)	2535 (99 7/8)	2549 (100 3/8)	2559 (100 3/4)	2564 (101)
<b>B</b> Ylens	660 (26)	609 (24)	566 (22 3/8)	522 (20 5/8)	479 (18 7/8)	435 (17 1/4)	392 (15 1/2)	348 (13 3/4)	305 (12 1/8)	261 (10 3/8)	218 (8 5/8)	174 (6 7/8)	131 (5 1/4)	88 (3 1/2)	44 (1 3/4)	0 (0)	-45 (-1 13/16)	-90 (-3 5/8)
<b>D</b> TD	2522 (99 3/8)	2517 (99 1/8)	2514 (99)	2511 (98 7/8)	2508 (98 3/4)	2506 (98 3/4)	2503 (98 5/8)	2501 (98 1/2)	2500 (98 1/2)	2498 (98 3/8)	2497 (98 3/8)	2498 (98 3/8)	2512 (99)	2524 (99 3/8)	2536 (99 7/8)	2549 (100 3/8)	2559 (100 3/4)	2566 (101 1/8)
<b>C</b> dVoff	0 (0)	9 (3/8)	17 (1 1/16)	24 (3 1/32)	31 (1 1/4)	39 (1 9/16)	46 (1 13/16)	53 (2 1/8)	61 (2 1/2)	68 (2 3/4)	69 (2 3/4)	69 (2 3/4)	69 (2 3/4)	69 (2 3/4)	70 (2 7/8)	70 (2 7/8)	70 (2 7/8)	70 (2 7/8)

**When using the 100 inch screen**

Unit: mm (inches)

a TA (deg)	15.2°	14°	13°	12°	11°	10°	9°	8°	7°	6°	5°	4°	3°	2°	1°	0°	-1°	-2°
<b>E</b> Xlens	2689 (105 7/8)	2699 (106 3/8)	2707 (106 5/8)	2714 (106 7/8)	2721 (107 1/4)	2727 (107 3/8)	2733 (107 5/8)	2737 (107 7/8)	2742 (108)	2745 (108 1/8)	2749 (108 1/4)	2754 (108 1/2)	2773 (109 1/4)	2788 (109 7/8)	2802 (110 3/8)	2817 (111)	2828 (111 3/8)	2834 (111 5/8)
<b>B</b> Ylens	730 (28 3/4)	673 (26 1/2)	625 (24 5/8)	577 (22 3/4)	529 (20 7/8)	481 (19)	433 (17 1/8)	385 (15 1/4)	337 (13 3/8)	289 (11 1/2)	241 (9 1/2)	193 (7 5/8)	145 (5 3/4)	97 (3 7/8)	49 (1 15/16)	0 (0)	-49 (-1 15/16)	-99 (-4)
<b>D</b> TD	2787 (109 3/4)	2782 (109 5/8)	2778 (109 3/8)	2775 (109 3/8)	2772 (109 1/4)	2769 (109 1/8)	2767 (109)	2764 (108 7/8)	2762 (108 3/4)	2761 (108 3/4)	2760 (108 3/4)	2761 (108 3/4)	2776 (109 3/8)	2789 (109 7/8)	2802 (110 3/8)	2817 (111)	2828 (111 3/8)	2835 (111 5/8)
<b>C</b> dVoff	0 (0)	10 (1 3/32)	19 (3/4)	26 (1 1/16)	35 (1 7/16)	43 (1 3/4)	51 (2 1/8)	59 (2 3/8)	67 (2 3/4)	76 (3)	77 (3 1/8)	77 (3 1/8)	77 (3 1/8)	77 (3 1/8)	78 (3 1/8)	78 (3 1/8)	78 (3 1/8)	78 (3 1/8)

**When using the 110 inch screen**

Unit: mm (inches)

a TA (deg)	15.2°	14°	13°	12°	11°	10°	9°	8°	7°	6°	5°	4°	3°	2°	1°	0°	-1°	-2°
<b>E</b> Xlens	2945 (116)	2956 (116 1/2)	2964 (116 3/4)	2972 (117 1/8)	2979 (117 3/8)	2986 (117 5/8)	2992 (117 7/8)	2997 (118)	3002 (118 1/4)	3006 (118 3/8)	3010 (118 5/8)	3016 (118 3/4)	3036 (119 5/8)	3052 (120 1/4)	3068 (120 7/8)	3085 (121 1/2)	3096 (122)	3102 (122 1/4)
<b>B</b> Ylens	800 (31 1/2)	737 (29 1/8)	684 (27)	632 (25)	579 (22 7/8)	526 (20 3/4)	474 (18 3/4)	421 (16 5/8)	369 (14 5/8)	316 (12 1/2)	263 (10 3/8)	211 (8 3/8)	159 (6 3/8)	107 (4 1/4)	54 (2 1/4)	0 (0)	-54 (-2 1/4)	-108 (-4 3/8)
<b>D</b> TD	3051 (120 1/8)	3046 (120)	3042 (119 7/8)	3038 (119 5/8)	3035 (119 1/2)	3032 (119 3/8)	3029 (119 3/8)	3027 (119 1/4)	3024 (119 1/8)	3022 (119)	3021 (119)	3023 (119 1/8)	3040 (119 3/4)	3054 (120 1/4)	3068 (120 7/8)	3085 (121 1/2)	3096 (122)	3104 (122 1/4)
<b>C</b> dVoff	0 (0)	11 (7/16)	20 (1 3/16)	29 (1 3/16)	38 (1 1/2)	47 (1 7/8)	56 (2 1/4)	65 (2 5/8)	74 (3)	83 (3 3/8)	84 (3 3/8)	84 (3 3/8)	84 (3 3/8)	85 (3 3/8)	85 (3 3/8)	85 (3 3/8)	86 (3 1/2)	86 (3 1/2)

Others

# List of the Projection Distance by Angle of Optical Axis

## When using the 120 inch screen

Unit: mm (inches)

a TA (deg)	15.2°	14°	13°	12°	11°	10°	9°	8°	7°	6°	5°	4°	3°	2°	1°	0°	-1°	-2°
<b>E</b> Xlens	3200 (126)	3212 (126 1/2)	3221 (126 7/8)	3230 (127 1/4)	3237 (127 1/2)	3245 (127 7/8)	3251 (128)	3257 (128 1/4)	3262 (128 1/2)	3266 (128 5/8)	3271 (128 7/8)	3277 (129 1/8)	3299 (130)	3317 (130 5/8)	3333 (131 1/4)	3352 (132)	3364 (132 1/2)	3371 (132 3/4)
<b>B</b> Ylens	870 (34 3/8)	801 (31 5/8)	744 (29 3/8)	686 (27 1/8)	629 (24 7/8)	572 (22 5/8)	515 (20 3/8)	458 (18 1/8)	401 (15 7/8)	343 (13 5/8)	286 (11 3/8)	229 (9 1/8)	173 (6 7/8)	116 (4 5/8)	58 (2 3/8)	0 (0)	-59 (-2 3/8)	-118 (-4 3/4)
<b>D</b> TD	3316 (130 5/8)	3310 (130 3/8)	3306 (130 1/4)	3302 (130)	3298 (129 7/8)	3295 (129 3/4)	3292 (129 5/8)	3289 (129 1/2)	3286 (129 3/8)	3284 (129 3/8)	3283 (129 3/8)	3285 (129 3/8)	3303 (130 1/8)	3319 (130 3/4)	3334 (131 3/8)	3352 (132)	3365 (132 1/2)	3373 (132 7/8)
<b>C</b> dVoff	0 (0)	12 (1/2)	22 (7/8)	32 (1 5/16)	42 (1 11/16)	52 (2 1/8)	61 (2 1/2)	71 (2 7/8)	81 (3 1/4)	91 (3 5/8)	92 (3 5/8)	92 (3 5/8)	92 (3 5/8)	92 (3 5/8)	93 (3 3/4)	93 (3 3/4)	93 (3 3/4)	94 (3 3/4)

## When using the 130 inch screen

Unit: mm (inches)

a TA (deg)	15.2°	14°	13°	12°	11°	10°	9°	8°	7°	6°	5°	4°	3°	2°	1°	0°	-1°	-2°
<b>E</b> Xlens	3457 (136 1/8)	3470 (136 5/8)	3480 (137 1/8)	3490 (137 1/2)	3498 (137 3/4)	3506 (138 1/8)	3513 (138 3/8)	3519 (138 5/8)	3525 (138 7/8)	3529 (139)	3534 (139 1/4)	3541 (139 1/2)	3564 (140 3/8)	3583 (141 1/8)	3602 (141 7/8)	3622 (142 5/8)	3635 (143 1/8)	3642 (143 1/2)
<b>B</b> Ylens	940 (37 1/8)	865 (34 1/8)	803 (31 5/8)	742 (29 1/4)	680 (26 7/8)	618 (24 3/8)	556 (22)	495 (19 1/2)	433 (17 1/8)	371 (14 5/8)	309 (12 1/4)	248 (9 7/8)	187 (7 3/8)	125 (5)	63 (2 1/2)	0 (0)	-63 (-2 1/2)	-127 (-5)
<b>D</b> TD	3583 (141 1/8)	3577 (140 7/8)	3572 (140 3/4)	3568 (140 1/2)	3563 (140 3/8)	3560 (140 1/4)	3557 (140 1/8)	3554 (140)	3551 (139 7/8)	3549 (139 3/4)	3548 (139 3/4)	3549 (139 3/4)	3569 (140 5/8)	3586 (141 1/4)	3602 (141 7/8)	3622 (142 5/8)	3635 (143 1/8)	3645 (143 5/8)
<b>C</b> dVoff	0 (0)	13 (17/32)	24 (31/32)	34 (1 3/8)	45 (1 13/16)	56 (2 1/4)	66 (2 5/8)	77 (3 1/8)	88 (3 1/2)	98 (3 7/8)	99 (4)	99 (4)	100 (4)	100 (4)	101 (4)	101 (4)	101 (4)	101 (4)

## When using the 140 inch screen

Unit: mm (inches)

a TA (deg)	15.2°	14°	13°	12°	11°	10°	9°	8°	7°	6°	5°	4°	3°	2°	1°	0°	-1°	-2°
<b>E</b> Xlens	3715 (146 3/8)	3729 (146 7/8)	3740 (147 1/4)	3750 (147 3/4)	3759 (148)	3767 (148 3/8)	3774 (148 5/8)	3781 (148 7/8)	3787 (149 1/8)	3792 (149 3/8)	3797 (149 1/2)	3804 (149 7/8)	3830 (150 7/8)	3850 (151 5/8)	3870 (152 3/8)	3891 (153 1/4)	3906 (153 7/8)	3914 (154 1/8)
<b>B</b> Ylens	1010 (39 7/8)	930 (36 5/8)	863 (34)	797 (31 1/2)	731 (28 7/8)	664 (26 1/4)	598 (23 5/8)	531 (21)	465 (18 3/8)	399 (15 3/4)	332 (13 1/8)	266 (10 1/2)	201 (8)	134 (5 3/8)	68 (2 3/4)	0 (0)	-68 (-2 3/4)	-137 (-5 1/2)
<b>D</b> TD	3850 (151 5/8)	3843 (151 3/8)	3838 (151 1/8)	3833 (151)	3829 (150 3/4)	3825 (150 5/8)	3822 (150 1/2)	3818 (150 3/8)	3815 (150 1/4)	3813 (150 1/8)	3812 (150 1/8)	3814 (150 1/4)	3835 (151)	3853 (151 3/4)	3871 (152 1/2)	3891 (153 1/4)	3906 (153 7/8)	3916 (154 1/4)
<b>C</b> dVoff	0 (0)	14 (9/16)	26 (1 1/16)	37 (1 1/2)	48 (1 15/16)	60 (2 3/8)	71 (2 7/8)	83 (3 3/8)	94 (3 3/4)	106 (4 1/4)	107 (4 1/4)	107 (4 1/4)	107 (4 1/4)	108 (4 3/8)	108 (4 3/8)	108 (4 3/8)	109 (4 3/8)	109 (4 3/8)

## When using the 150 inch screen

Unit: mm (inches)

a TA (deg)	15.2°	14°	13°	12°	11°	10°	9°	8°	7°	6°	5°	4°	3°	2°	1°	0°	-1°	-2°
<b>E</b> Xlens	3972 (156 1/2)	3987 (157)	3999 (157 1/2)	4009 (157 7/8)	4019 (158 1/4)	4028 (158 5/8)	4036 (159)	4043 (159 1/4)	4050 (159 1/2)	4055 (159 3/4)	4060 (159 7/8)	4068 (160 1/4)	4095 (161 1/4)	4117 (162 1/8)	4138 (163)	4161 (163 7/8)	4176 (164 1/2)	4185 (164 7/8)
<b>B</b> Ylens	1081 (42 5/8)	994 (39 1/4)	923 (36 3/8)	852 (33 5/8)	781 (30 3/4)	710 (28)	639 (25 1/4)	568 (22 3/8)	497 (19 5/8)	426 (16 7/8)	355 (14)	284 (11 1/4)	215 (8 1/2)	144 (5 3/4)	72 (2 7/8)	0 (0)	-73 (-2 7/8)	-146 (-5 3/4)
<b>D</b> TD	4117 (162 1/8)	4109 (161 7/8)	4104 (161 5/8)	4099 (161 1/2)	4094 (161 1/4)	4090 (161 1/8)	4086 (160 7/8)	4083 (160 3/4)	4080 (160 3/4)	4077 (160 5/8)	4076 (160 1/2)	4078 (160 5/8)	4101 (161 1/2)	4120 (162 1/4)	4139 (163)	4161 (163 7/8)	4177 (164 1/2)	4188 (165)
<b>C</b> dVoff	0 (0)	15 (19/32)	28 (1 1/8)	40 (1 5/8)	52 (2 1/8)	64 (2 5/8)	76 (3)	89 (3 5/8)	101 (4)	113 (4 1/2)	115 (4 5/8)	115 (4 5/8)	115 (4 5/8)	115 (4 5/8)	116 (4 5/8)	116 (4 5/8)	117 (4 5/8)	117 (4 5/8)

Others

**When using the 160 inch screen**

Unit: mm (inches)

a TA (deg)	15.2°	14°	13°	12°	11°	10°	9°	8°	7°	6°	5°	4°	3°	2°	1°	0°	-1°	-2°
<b>E</b> Xlens	4229 (166 1/2)	4245 (167 1/4)	4258 (167 3/4)	4269 (168 1/8)	4279 (168 1/2)	4289 (168 7/8)	4297 (169 1/4)	4305 (169 1/2)	4312 (169 7/8)	4317 (170)	4323 (170 1/4)	4331 (170 5/8)	4360 (171 3/4)	4384 (172 5/8)	4406 (173 1/2)	4431 (174 1/2)	4447 (175 1/8)	4456 (175 1/2)
<b>B</b> Ylens	1151 (45 3/8)	1059 (41 3/4)	983 (38 3/4)	907 (35 3/4)	832 (32 7/8)	756 (29 7/8)	681 (26 7/8)	605 (23 7/8)	529 (20 7/8)	454 (17 7/8)	378 (15)	303 (12)	229 (9 1/8)	153 (6 1/8)	77 (3 1/8)	0 (0)	-78 (-3 1/8)	-156 (-6 1/4)
<b>D</b> TD	4383 (172 5/8)	4375 (172 1/4)	4370 (172 1/8)	4364 (171 7/8)	4359 (171 5/8)	4355 (171 1/2)	4351 (171 3/8)	4347 (171 1/4)	4344 (171 1/8)	4341 (171)	4340 (171 7/8)	4342 (171)	4366 (172)	4386 (172 3/4)	4407 (173 5/8)	4431 (174 1/2)	4447 (175 1/8)	4459 (175 5/8)
<b>C</b> dVoff	0 (0)	16 (2 1/32)	30 (1 13/16)	42 (1 11/16)	55 (2 1/4)	69 (2 3/4)	81 (3 1/4)	95 (3 3/4)	108 (4 3/8)	121 (4 7/8)	122 (4 7/8)	122 (4 7/8)	123 (4 7/8)	123 (4 7/8)	124 (5)	124 (5)	124 (5)	125 (5)

**When using the 170 inch screen**

Unit: mm (inches)

a TA (deg)	15.2°	14°	13°	12°	11°	10°	9°	8°	7°	6°	5°	4°	3°	2°	1°	0°	-1°	-2°
<b>E</b> Xlens	4486 (176 3/4)	4504 (177 3/8)	4516 (177 7/8)	4528 (178 3/8)	4539 (178 3/4)	4549 (179 1/8)	4559 (179 5/8)	4567 (179 7/8)	4574 (180 1/8)	4580 (180 3/8)	4586 (180 5/8)	4595 (181)	4625 (182 1/8)	4650 (183 1/8)	4674 (184 1/8)	4700 (185 1/8)	4717 (185 3/4)	4727 (186 1/8)
<b>B</b> Ylens	1221 (48 1/8)	1123 (44 1/4)	1043 (41 1/8)	963 (38)	882 (34 3/4)	802 (31 5/8)	722 (28 1/2)	642 (25 3/8)	562 (22 1/4)	481 (19)	401 (15 7/8)	321 (12 3/4)	242 (9 5/8)	162 (6 1/2)	82 (3 1/4)	0 (0)	-82 (-3 1/4)	-165 (-6 1/2)
<b>D</b> TD	4650 (183 1/8)	4641 (182 3/4)	4635 (182 1/2)	4630 (182 3/8)	4624 (182 1/8)	4620 (182)	4615 (181 3/4)	4611 (181 5/8)	4608 (181 1/2)	4605 (181 3/8)	4604 (181 3/8)	4606 (181 3/8)	4631 (182 3/8)	4653 (183 1/4)	4675 (184 1/8)	4700 (185 1/8)	4718 (185 3/4)	4730 (186 1/4)
<b>C</b> dVoff	0 (0)	17 (1 1/16)	32 (1 5/16)	45 (1 13/16)	59 (2 3/8)	73 (2 7/8)	86 (3 1/2)	101 (4)	114 (4 1/2)	129 (5 1/8)	130 (5 1/8)	130 (5 1/8)	130 (5 1/8)	131 (5 1/4)	131 (5 1/4)	132 (5 1/4)	132 (5 1/4)	132 (5 1/4)

**When using the 180 inch screen**

Unit: mm (inches)

a TA (deg)	15.2°	14°	13°	12°	11°	10°	9°	8°	7°	6°	5°	4°	3°	2°	1°	0°	-1°	-2°
<b>E</b> Xlens	4743 (186 3/4)	4762 (187 1/2)	4775 (188)	4788 (188 5/8)	4800 (189)	4810 (189 3/8)	4820 (189 7/8)	4828 (190 1/8)	4836 (190 1/2)	4842 (190 3/4)	4849 (191)	4858 (191 3/8)	4890 (192 5/8)	4917 (193 5/8)	4942 (194 5/8)	4969 (195 3/4)	4987 (196 3/8)	4997 (196 3/4)
<b>B</b> Ylens	1292 (50 7/8)	1187 (46 3/4)	1102 (43 1/2)	1018 (40 1/8)	933 (36 3/4)	848 (33 1/2)	763 (30 1/8)	679 (26 3/4)	594 (23 1/2)	509 (20 1/8)	424 (16 3/4)	340 (13 1/2)	256 (10 1/8)	172 (6 7/8)	86 (3 1/2)	0 (0)	-87 (-3 1/2)	-175 (-7)
<b>D</b> TD	4916 (193 5/8)	4907 (193 1/4)	4901 (193)	4895 (192 3/4)	4889 (192 1/2)	4884 (192 3/8)	4880 (192 1/4)	4876 (192)	4872 (191 7/8)	4869 (191 3/4)	4867 (191 5/8)	4870 (191 3/4)	4897 (192 7/8)	4920 (193 3/4)	4942 (194 5/8)	4969 (195 3/4)	4988 (196 1/2)	5001 (197)
<b>C</b> dVoff	0 (0)	18 (2 3/32)	33 (1 5/16)	47 (1 7/8)	62 (2 1/2)	77 (3 1/8)	91 (3 5/8)	107 (4 1/4)	121 (4 7/8)	136 (5 3/8)	137 (5 1/2)	137 (5 1/2)	138 (5 1/2)	138 (5 1/2)	139 (5 1/2)	139 (5 1/2)	140 (5 5/8)	140 (5 5/8)

**When using the 190 inch screen**

Unit: mm (inches)

a TA (deg)	15.2°	14°	13°	12°	11°	10°	9°	8°	7°	6°	5°	4°	3°	2°	1°	0°	-1°	-2°
<b>E</b> Xlens	4999 (196 7/8)	5018 (197 5/8)	5033 (198 1/4)	5046 (198 3/4)	5058 (199 1/4)	5069 (199 5/8)	5079 (200)	5088 (200 3/8)	5096 (200 3/4)	5103 (201)	5110 (201 1/4)	5120 (201 5/8)	5153 (202 7/8)	5181 (204)	5208 (205 1/8)	5237 (206 1/4)	5256 (207)	5267 (207 3/8)
<b>B</b> Ylens	1362 (53 5/8)	1251 (49 3/8)	1162 (45 3/4)	1073 (42 1/4)	983 (38 3/4)	894 (35 1/4)	805 (31 3/4)	715 (28 1/4)	626 (24 3/4)	536 (21 1/8)	447 (17 5/8)	358 (14 1/8)	270 (10 3/4)	181 (7 1/4)	91 (3 5/8)	0 (0)	-92 (-3 5/8)	-184 (-7 1/4)
<b>D</b> TD	5181 (204)	5172 (203 5/8)	5165 (203 3/8)	5159 (203 1/8)	5153 (202 7/8)	5147 (202 3/4)	5143 (202 1/2)	5138 (202 3/8)	5135 (202 1/4)	5131 (202 1/8)	5130 (202)	5132 (202 1/8)	5161 (203 1/4)	5185 (204 1/4)	5209 (205 1/8)	5237 (206 1/4)	5257 (207)	5270 (207 1/2)
<b>C</b> dVoff	0 (0)	19 (3/4)	35 (1 7/16)	50 (2)	66 (2 5/8)	82 (3 1/4)	96 (3 7/8)	113 (4 1/2)	128 (5 1/8)	144 (5 3/4)	145 (5 3/4)	145 (5 3/4)	146 (5 3/4)	146 (5 3/4)	147 (5 7/8)	147 (5 7/8)	148 (5 7/8)	148 (5 7/8)

Others

# List of the Projection Distance by Angle of Optical Axis

## When using the 200 inch screen

Unit: mm (inches)

a TA (deg)	15.2°	14°	13°	12°	11°	10°	9°	8°	7°	6°	5°	4°	3°	2°	1°	0°	-1°	-2°
<b>E</b> Xlens	5254 (206 7/8)	5275 (207 3/4)	5290 (208 3/8)	5304 (208 7/8)	5317 (209 3/8)	5328 (209 7/8)	5339 (210 1/4)	5348 (210 5/8)	5357 (211)	5364 (211 1/4)	5371 (211 1/2)	5381 (211 7/8)	5417 (213 3/8)	5446 (214 1/2)	5474 (215 5/8)	5504 (216 3/4)	5524 (217 1/2)	5536 (218)
<b>B</b> Ylens	1432 (56 1/2)	1315 (51 7/8)	1221 (48 1/8)	1127 (44 3/8)	1033 (40 3/4)	940 (37 1/8)	846 (33 3/8)	752 (29 5/8)	658 (26)	564 (22 1/4)	470 (18 5/8)	376 (14 7/8)	284 (11 1/4)	190 (7 1/2)	96 (3 7/8)	0 (0)	-96 (-3 7/8)	-193 (-7 5/8)
<b>D</b> TD	5446 (214 1/2)	5436 (214 1/8)	5429 (213 7/8)	5422 (213 1/2)	5416 (213 1/4)	5411 (213 1/8)	5406 (212 7/8)	5401 (212 3/4)	5397 (212 1/2)	5394 (212 3/8)	5392 (212 3/8)	5394 (212 3/8)	5424 (213 5/8)	5450 (214 5/8)	5475 (215 5/8)	5504 (216 3/4)	5525 (217 5/8)	5539 (218 1/8)
<b>C</b> dVoff	0 (0)	21 (2 7/32)	37 (1 1/2)	53 (2 1/8)	69 (2 3/4)	86 (3 1/2)	101 (4)	119 (4 3/4)	135 (5 3/8)	152 (6)	153 (6 1/8)	153 (6 1/8)	154 (6 1/8)	154 (6 1/8)	155 (6 1/8)	155 (6 1/8)	156 (6 1/4)	156 (6 1/4)

## When using the 210 inch screen

Unit: mm (inches)

a TA (deg)	15.2°	14°	13°	12°	11°	10°	9°	8°	7°	6°	5°	4°	3°	2°	1°	0°	-1°	-2°
<b>E</b> Xlens	5511 (217)	5533 (217 7/8)	5549 (218 1/2)	5563 (219 1/8)	5577 (219 5/8)	5589 (220 1/8)	5600 (220 1/2)	5610 (220 7/8)	5619 (221 1/4)	5626 (221 1/2)	5634 (221 7/8)	5644 (222 1/4)	5682 (223 3/4)	5713 (225)	5742 (226 1/8)	5774 (227 3/8)	5794 (228 1/8)	5807 (228 5/8)
<b>B</b> Ylens	1502 (59 1/4)	1380 (54 3/8)	1281 (50 1/2)	1183 (46 5/8)	1084 (42 3/4)	986 (38 7/8)	887 (35)	788 (31 1/8)	690 (27 1/4)	591 (23 3/8)	493 (19 1/2)	395 (15 5/8)	298 (11 3/4)	199 (7 7/8)	100 (4)	0 (0)	-101 (-4)	-203 (-8)
<b>D</b> TD	5713 (225)	5702 (224 1/2)	5695 (224 1/4)	5688 (224)	5681 (223 3/4)	5675 (223 1/2)	5670 (223 1/4)	5665 (223 1/8)	5661 (223 7/8)	5657 (222 3/4)	5655 (222 3/4)	5658 (222 7/8)	5690 (224 1/8)	5716 (225 1/8)	5743 (226 1/8)	5774 (227 3/8)	5795 (228 1/4)	5810 (228 3/4)
<b>C</b> dVoff	0 (0)	22 (7/8)	39 (1 9/16)	55 (2 1/4)	73 (2 7/8)	90 (3 5/8)	107 (4 1/4)	125 (5)	142 (5 5/8)	159 (6 3/8)	161 (6 3/8)	160 (6 3/8)	161 (6 3/8)	162 (6 1/2)	163 (6 1/2)	163 (6 1/2)	163 (6 1/2)	164 (6 1/2)

## When using the 220 inch screen

Unit: mm (inches)

a TA (deg)	15.2°	14°	13°	12°	11°	10°	9°	8°	7°	6°	5°	4°	3°	2°	1°	0°	-1°	-2°
<b>E</b> Xlens	5768 (227 1/8)	5791 (228)	5807 (228 5/8)	5823 (229 3/8)	5837 (229 7/8)	5850 (230 3/8)	5861 (230 7/8)	5872 (231 1/4)	5881 (231 5/8)	5889 (231 7/8)	5897 (232 1/4)	5908 (232 5/8)	5947 (234 1/4)	5979 (235 1/2)	6009 (236 5/8)	6043 (238)	6065 (238 7/8)	6077 (239 3/8)
<b>B</b> Ylens	1573 (62)	1444 (56 7/8)	1341 (52 7/8)	1238 (48 3/4)	1135 (44 3/4)	1031 (40 5/8)	928 (36 5/8)	825 (32 1/2)	722 (28 1/2)	619 (24 3/8)	516 (20 3/8)	413 (16 3/8)	312 (12 3/8)	209 (8 1/4)	105 (4 1/4)	0 (0)	-106 (-4 1/4)	-212 (-8 3/8)
<b>D</b> TD	5979 (235 1/2)	5968 (235)	5960 (234 3/4)	5953 (234 3/8)	5946 (234 1/8)	5940 (234 7/8)	5934 (233 5/8)	5929 (233 1/2)	5925 (233 3/8)	5921 (233 1/8)	5919 (233 1/8)	5922 (233 1/4)	5955 (234 1/2)	5983 (235 5/8)	6010 (236 5/8)	6043 (238)	6066 (238 7/8)	6081 (239 1/2)
<b>C</b> dVoff	0 (0)	23 (2 9/32)	41 (1 5/8)	58 (2 3/8)	76 (3)	94 (3 3/4)	112 (4 1/2)	131 (5 1/4)	148 (5 7/8)	167 (6 5/8)	168 (6 5/8)	168 (6 5/8)	169 (6 3/4)	169 (6 3/4)	170 (6 3/4)	170 (6 3/4)	171 (6 3/4)	171 (6 3/4)

## When using the 230 inch screen

Unit: mm (inches)

a TA (deg)	15.2°	14°	13°	12°	11°	10°	9°	8°	7°	6°	5°	4°	3°	2°	1°	0°	-1°	-2°
<b>E</b> Xlens	6025 (237 1/4)	6049 (238 1/4)	6066 (238 7/8)	6082 (239 1/2)	6097 (240 1/8)	6110 (240 5/8)	6122 (241 1/8)	6133 (241 1/2)	6143 (242)	6151 (242 1/4)	6159 (242 5/8)	6171 (243)	6212 (244 5/8)	6245 (245 7/8)	6277 (247 1/4)	6312 (248 5/8)	6335 (249 1/2)	6348 (250)
<b>B</b> Ylens	1643 (64 3/4)	1508 (59 3/8)	1401 (55 1/4)	1293 (51)	1185 (46 3/4)	1077 (42 1/2)	970 (38 1/4)	862 (34)	754 (29 3/4)	647 (25 1/2)	539 (21 1/4)	432 (17 1/8)	326 (12 7/8)	218 (8 5/8)	110 (4 3/8)	0 (0)	-111 (-4 3/8)	-222 (-8 3/4)
<b>D</b> TD	6245 (245 7/8)	6234 (245 1/2)	6226 (245 1/8)	6218 (244 7/8)	6211 (244 5/8)	6205 (244 3/8)	6199 (244 1/8)	6193 (243 7/8)	6189 (243 3/4)	6185 (243 5/8)	6183 (243 1/2)	6186 (243 5/8)	6220 (245)	6249 (246 1/8)	6278 (247 1/4)	6312 (248 5/8)	6336 (249 1/2)	6352 (250 1/8)
<b>C</b> dVoff	0 (0)	24 (3 1/32)	43 (1 3/4)	61 (2 1/2)	80 (3 1/4)	99 (4)	117 (4 5/8)	136 (5 3/8)	155 (6 1/8)	174 (6 7/8)	176 (7)	176 (7)	176 (7)	177 (7)	178 (7 1/8)	178 (7 1/8)	179 (7 1/8)	179 (7 1/8)

Others



**When using the 240 inch screen**

Unit: mm (inches)

a TA (deg)	15.2°	14°	13°	12°	11°	10°	9°	8°	7°	6°	5°	4°	3°	2°	1°	0°	-1°	-2°
<b>E</b> Xlens	6282 (247 3/8)	6307 (248 3/8)	6325 (249 1/8)	6342 (249 3/4)	6357 (250 3/8)	6371 (250 7/8)	6384 (251 3/8)	6395 (251 7/8)	6405 (252 1/4)	6413 (252 1/2)	6422 (252 7/8)	6434 (253 3/8)	6477 (255 1/8)	6512 (256 1/2)	6545 (257 3/4)	6581 (259 1/8)	6605 (260 1/8)	6619 (260 5/8)
<b>B</b> Ylens	1713 (67 1/2)	1573 (62)	1460 (57 1/2)	1348 (53 1/8)	1236 (48 3/4)	1123 (44 1/4)	1011 (39 7/8)	899 (35 1/2)	786 (31)	674 (26 5/8)	562 (22 1/4)	450 (17 3/4)	339 (13 3/8)	227 (9)	114 (4 1/2)	0 (0)	-115 (-4 5/8)	-231 (-9 1/8)
<b>D</b> TD	6512 (256 1/2)	6500 (256)	6491 (255 5/8)	6483 (255 1/4)	6476 (255)	6469 (254 3/4)	6463 (254 1/2)	6458 (254 3/8)	6453 (254 1/8)	6449 (254)	6446 (253 7/8)	6450 (254)	6485 (255 3/8)	6516 (256 5/8)	6546 (257 3/4)	6581 (259 1/8)	6606 (260 1/8)	6623 (260 3/4)
<b>C</b> dVoff	0 (0)	25 (1)	45 (1 13/16)	63 (2 1/2)	83 (3 3/8)	103 (4 1/8)	122 (4 7/8)	142 (5 5/8)	162 (6 1/2)	182 (7 1/4)	184 (7 1/4)	183 (7 1/4)	184 (7 1/4)	185 (7 3/8)	186 (7 3/8)	186 (7 3/8)	187 (7 3/8)	187 (7 3/8)

**When using the 250 inch screen**

Unit: mm (inches)

a TA (deg)	15.2°	14°	13°	12°	11°	10°	9°	8°	7°	6°	5°	4°	3°	2°	1°	0°	-1°	-2°
<b>E</b> Xlens	6539 (257 1/2)	6565 (258 1/2)	6584 (259 1/4)	6601 (260)	6617 (260 5/8)	6631 (261 1/8)	6645 (261 5/8)	6656 (262 1/8)	6667 (262 1/2)	6676 (262 7/8)	6685 (263 1/4)	6697 (263 3/4)	6741 (265 1/2)	6778 (266 7/8)	6812 (268 1/4)	6850 (269 3/4)	6875 (270 3/4)	6889 (271 1/4)
<b>B</b> Ylens	1783 (70 1/4)	1637 (64 1/2)	1520 (59 7/8)	1403 (55 1/4)	1286 (50 3/4)	1169 (46 1/8)	1052 (41 1/2)	936 (36 7/8)	819 (32 1/4)	702 (27 3/4)	585 (23 1/8)	468 (18 1/2)	353 (14)	237 (9 3/8)	119 (4 3/4)	0 (0)	-120 (-4 3/4)	-241 (-9 1/2)
<b>D</b> TD	6778 (266 7/8)	6766 (266 1/2)	6757 (266 1/8)	6749 (265 3/4)	6741 (265 1/2)	6734 (265 1/8)	6728 (265)	6722 (264 3/4)	6717 (264 1/2)	6713 (264 3/8)	6710 (264 1/4)	6714 (264 3/8)	6751 (265 7/8)	6782 (267 1/8)	6814 (268 3/8)	6850 (269 3/4)	6876 (270 3/4)	6894 (271 1/2)
<b>C</b> dVoff	0 (0)	26 (1 1/16)	46 (1 13/16)	66 (2 5/8)	86 (3 1/2)	107 (4 1/4)	127 (5)	148 (5 7/8)	169 (6 3/4)	189 (7 1/2)	191 (7 5/8)	191 (7 5/8)	192 (7 5/8)	192 (7 5/8)	194 (7 3/4)	194 (7 3/4)	194 (7 3/4)	195 (7 3/4)

**When using the 260 inch screen**

Unit: mm (inches)

a TA (deg)	15.2°	14°	13°	12°	11°	10°	9°	8°	7°	6°	5°	4°	3°	2°	1°	0°	-1°	-2°
<b>E</b> Xlens	6798 (267 3/4)	6824 (268 3/4)	6844 (269 1/2)	6862 (270 1/4)	6878 (270 7/8)	6893 (271 1/2)	6907 (272)	6919 (272 1/2)	6930 (272 7/8)	6939 (273 1/4)	6949 (273 5/8)	6962 (274 1/8)	7008 (276)	7046 (277 1/2)	7082 (278 7/8)	7121 (280 3/8)	7147 (281 1/2)	7162 (282)
<b>B</b> Ylens	1854 (73)	1702 (67 1/8)	1580 (62 1/4)	1459 (57 1/2)	1337 (52 3/4)	1216 (47 7/8)	1094 (43 1/8)	972 (38 3/8)	851 (33 5/8)	729 (28 3/4)	608 (24)	487 (19 1/4)	367 (14 1/2)	246 (9 3/4)	124 (5)	0 (0)	-125 (-5)	-250 (-9 7/8)
<b>D</b> TD	7046 (277 7/16)	7033 (276 15/16)	7024 (276 19/32)	7015 (276 7/32)	7007 (275 29/32)	7000 (275 5/8)	6993 (275 3/8)	6987 (275 1/8)	6982 (275)	6978 (274 7/8)	6975 (274 3/4)	6979 (274 7/8)	7017 (276 5/16)	7050 (277 5/8)	7083 (279)	7121 (280 1/2)	7148 (281 1/2)	7166 (282 1/4)
<b>C</b> dVoff	0 (0)	27 (1 1/8)	48 (1 15/16)	68 (2 3/4)	90 (3 5/8)	112 (4 1/2)	132 (5 1/4)	154 (6 1/8)	175 (7)	197 (7 7/8)	199 (7 7/8)	198 (7 7/8)	199 (7 7/8)	200 (7 7/8)	201 (8)	201 (8)	202 (8)	202 (8)

**When using the 270 inch screen**

Unit: mm (inches)

a TA (deg)	15.2°	14°	13°	12°	11°	10°	9°	8°	7°	6°	5°	4°	3°	2°	1°	0°	-1°	-2°
<b>E</b> Xlens	7056 (277 7/8)	7083 (277 7/8)	7104 (279 3/4)	7123 (280 1/2)	7140 (281 1/8)	7155 (281 3/4)	7170 (282 3/8)	7182 (282 7/8)	7193 (283 1/4)	7203 (283 5/8)	7213 (284)	7226 (284 1/2)	7274 (286 1/2)	7313 (288)	7351 (289 1/2)	7392 (291 1/8)	7418 (292 1/8)	7434 (292 3/4)
<b>B</b> Ylens	1924 (75 3/4)	1766 (69 5/8)	1640 (64 5/8)	1514 (59 5/8)	1388 (54 3/4)	1262 (49 3/4)	1136 (44 3/4)	1009 (39 3/4)	883 (34 7/8)	757 (29 7/8)	631 (24 7/8)	505 (20)	381 (15)	255 (10 1/8)	128 (5 1/8)	0 (0)	-129 (-5 1/8)	-260 (-10 1/4)
<b>D</b> TD	7314 (288)	7300 (287 1/2)	7291 (287 1/8)	7282 (286 3/4)	7273 (286 3/8)	7266 (286 1/8)	7259 (285 7/8)	7253 (285 5/8)	7247 (285 3/8)	7243 (285 1/4)	7240 (285 1/8)	7244 (285 1/4)	7284 (286 7/8)	7318 (288 1/8)	7352 (289 1/2)	7392 (291 1/8)	7419 (292 1/8)	7438 (292 7/8)
<b>C</b> dVoff	0 (0)	28 (1 1/8)	50 (2)	71 (2 7/8)	93 (3 3/4)	116 (4 5/8)	137 (5 1/2)	160 (6 3/8)	182 (7 1/4)	204 (8 1/8)	206 (8 1/8)	206 (8 1/8)	207 (8 1/4)	207 (8 1/4)	209 (8 1/4)	209 (8 1/4)	210 (8 3/8)	210 (8 3/8)

Others

# List of the Projection Distance by Angle of Optical Axis

## When using the 280 inch screen

Unit: mm (inches)

a TA (deg)	15.2°	14°	13°	12°	11°	10°	9°	8°	7°	6°	5°	4°	3°	2°	1°	0°	-1°	-2°
<b>E</b> Xlens	7314 (288)	7343 (289 1/8)	7364 (290)	7383 (290 3/4)	7401 (291 1/2)	7417 (292 1/8)	7432 (292 3/8)	7445 (293 1/8)	7457 (293 5/8)	7467 (294)	7477 (294 3/8)	7491 (295)	7540 (296 7/8)	7581 (298 1/2)	7620 (300)	7662 (301 3/4)	7690 (302 7/8)	7706 (303 1/2)
<b>B</b> Ylens	1995 (78 5/8)	1831 (72 1/8)	1700 (67)	1569 (61 7/8)	1439 (56 3/4)	1308 (51 1/2)	1177 (46 3/8)	1046 (41 1/4)	916 (36 1/8)	785 (31)	654 (25 3/4)	524 (20 3/4)	395 (15 5/8)	265 (10 1/2)	133 (5 1/4)	0 (0)	-134 (-5 3/8)	-269 (-10 5/8)
<b>D</b> TD	7581 (298 1/2)	7568 (298)	7557 (297 5/8)	7548 (291 1/4)	7540 (296 7/8)	7532 (296 5/8)	7525 (296 3/8)	7518 (296)	7513 (295 7/8)	7508 (295 5/8)	7505 (295 1/2)	7509 (295 3/4)	7551 (297 3/8)	7586 (298 3/4)	7621 (300 1/8)	7662 (301 3/4)	7691 (302 7/8)	7711 (303 5/8)
<b>C</b> dVoff	0 (0)	29 (1 3/16)	52 (2 1/8)	74 (3)	97 (3 7/8)	120 (4 3/4)	142 (5 5/8)	166 (6 5/8)	188 (7 1/2)	212 (8 3/8)	214 (8 1/2)	213 (8 1/2)	214 (8 1/2)	215 (8 1/2)	216 (8 5/8)	216 (8 5/8)	217 (8 5/8)	218 (8 5/8)

## When using the 290 inch screen

Unit: mm (inches)

a TA (deg)	15.2°	14°	13°	12°	11°	10°	9°	8°	7°	6°	5°	4°	3°	2°	1°	0°	-1°	-2°
<b>E</b> Xlens	7573 (298 1/4)	7602 (299 3/8)	7624 (300 1/4)	7644 (301)	7662 (301 3/4)	7679 (302 3/8)	7695 (303)	7708 (303 1/2)	7720 (304)	7731 (304 3/8)	7741 (304 7/8)	7755 (305 3/8)	7807 (307 3/8)	7849 (309 1/8)	7889 (310 5/8)	7933 (312 3/8)	7961 (313 1/2)	7978 (314 1/8)
<b>B</b> Ylens	2065 (81 3/8)	1895 (74 5/8)	1760 (69 3/8)	1625 (64)	1489 (58 5/8)	1354 (53 3/8)	1219 (48)	1083 (42 3/4)	948 (37 3/8)	813 (32 1/8)	677 (26 3/4)	542 (21 3/8)	409 (16 1/8)	274 (10 7/8)	138 (5 1/2)	0 (0)	-139 (-5 1/2)	-279 (-11)
<b>D</b> TD	7849 (309 1/8)	7835 (308 1/2)	7824 (308 1/8)	7815 (307 3/4)	7806 (307 3/8)	7798 (307 1/8)	7791 (306 3/4)	7784 (306 1/2)	7778 (306 1/4)	7773 (306 1/8)	7770 (306)	7774 (306 1/8)	7817 (307 7/8)	7854 (309 1/4)	7890 (310 3/4)	7933 (312 3/8)	7963 (313 5/8)	7983 (314 3/8)
<b>C</b> dVoff	0 (0)	30 (1 3/16)	54 (2 1/4)	76 (3)	100 (4)	124 (5)	147 (5 7/8)	172 (6 7/8)	195 (7 3/4)	219 (8 5/8)	221 (8 3/4)	221 (8 3/4)	222 (8 3/4)	223 (8 7/8)	224 (8 7/8)	224 (8 7/8)	225 (8 7/8)	225 (8 7/8)

## When using the 300 inch screen

Unit: mm (inches)

a TA (deg)	15.2°	14°	13°	12°	11°	10°	9°	8°	7°	6°	5°	4°	3°	2°	1°	0°	-1°	-2°
<b>E</b> Xlens	7831 (308 3/8)	7861 (309 1/2)	7884 (310 1/2)	7905 (311 1/4)	7924 (312)	7941 (312 3/4)	7957 (313 3/8)	7971 (313 7/8)	7983 (314 3/8)	7994 (314 3/4)	8005 (315 1/4)	8020 (315 3/4)	8073 (317 7/8)	8117 (319 5/8)	8158 (321 1/4)	8203 (323)	8233 (324 1/4)	8250 (324 7/8)
<b>B</b> Ylens	2135 (84 1/8)	1960 (77 1/4)	1820 (71 3/4)	1680 (66 1/4)	1540 (60 3/4)	1400 (55 1/8)	1260 (49 5/8)	1120 (44 1/8)	980 (38 5/8)	840 (33 1/8)	700 (27 5/8)	561 (22 1/8)	423 (16 3/4)	283 (11 1/4)	142 (5 5/8)	0 (0)	-144 (-5 3/4)	-288 (-11 3/8)
<b>D</b> TD	8117 (319 5/8)	8102 (319)	8091 (318 5/8)	8081 (318 1/4)	8072 (317 7/8)	8064 (317 1/2)	8056 (317 1/4)	8049 (317)	8043 (316 3/4)	8038 (316 1/2)	8035 (316 3/8)	8040 (316 5/8)	8084 (318 3/8)	8122 (319 7/8)	8159 (321 1/4)	8203 (323)	8234 (324 1/4)	8255 (325)
<b>C</b> dVoff	0 (0)	31 (1 1/4)	55 (2 1/4)	79 (3 1/8)	103 (4 1/8)	128 (5 1/8)	152 (6)	177 (7)	202 (8)	226 (9)	229 (9 1/8)	228 (9)	229 (9 1/8)	230 (9 1/8)	232 (9 1/4)	232 (9 1/4)	232 (9 1/4)	233 (9 1/4)

Others

# *Appendix*

---

This chapter explains the installation of special optical systems such as the system using a curved screen and the VR (Virtual Reality) system using multiple projectors.

For calculating the installation measurements of these systems, apply “List of the Projection Distance by Angle of Optical Axis (for Flat Screen)” on pages 116 to 122.

# Installing the Curved Screen

## Installation Measurements for the Curved Screen

You can calculate the installation measurements for a curved screen by applying “List of the Projection Distance by Angle of Optical Axis (for Flat Screen)” on pages 116 to 122.

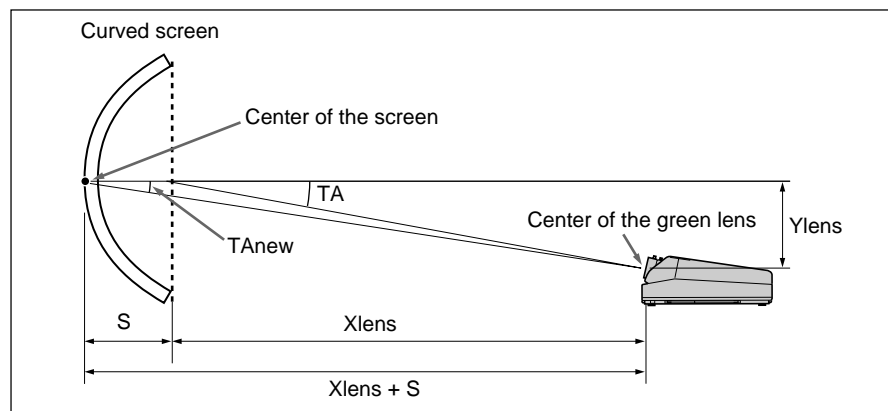

- 1** Check your installation conditions.
  - Screen size to be used in inches
  - Radius of curvature of the screen (R)
  - Horizontal distance between the center of the screen and the plane across the corners of the screen (S)
- 2** Find the values  $X_{lens}$  and  $Y_{lens}$  in the table for your screen size in “List of the Projection Distance by Angle of Optical Axis.”
- 3** Calculate the horizontal projection distance and the actual optical axis angle using the following formulas.

Horizontal projection distance:  $X_{lens} + S$

Actual optical axis angle:  $TA_{new} = \tan^{-1} \left( \frac{Y_{lens}}{X_{lens} + S} \right)$

**Example:** When using a 100 inch screen with 4 : 3 aspect ratio, 3000 mm radius of curvature (R) and 288 mm horizontal distance (S), and setting  $Y_{lens}$  at 577 mm

According to the table for a 100 inch screen on page 117, find the value of  $X_{lens}$  where  $Y_{lens}$  is 577 mm.  $X_{lens}$  is 2714 mm.

Therefore,

Horizontal projection distance:  $X_{lens} + S = 2714 + 288 = 2996$  (mm)

Actual optical axis angle:

$$TA_{new} = \tan^{-1} \left( \frac{Y_{lens}}{X_{lens} + S} \right) = \tan^{-1} \left( \frac{577}{2996} \right) = 10.9^\circ$$

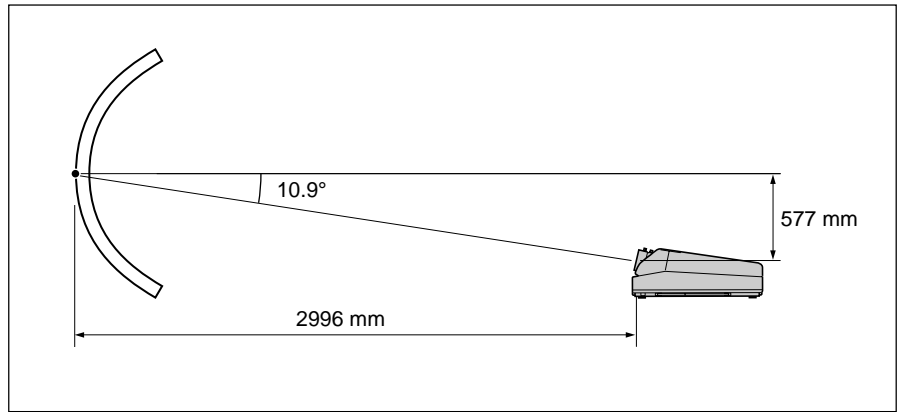

**When the screen is inclined**

Rotate the whole system around the center of the screen as illustrated below.

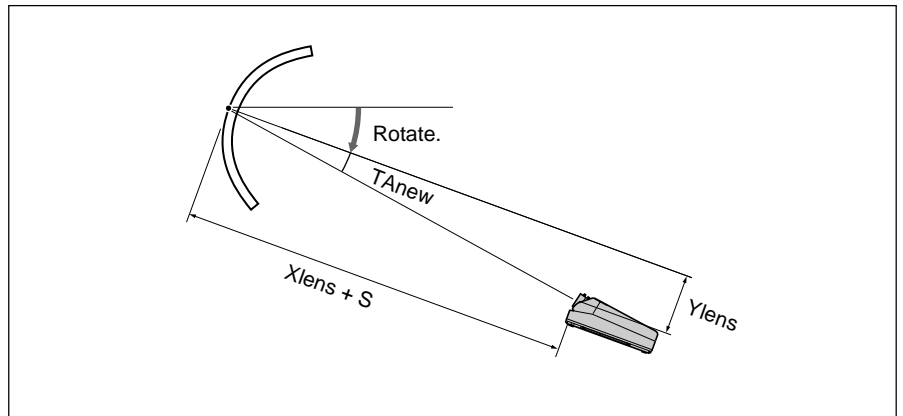

# Installing the Curved Screen

## Setting the Switches on the D Board

The S3, S4 and S5 switches on the D board should be set according to the radius of curvature (R) of the curved screen and optical axis angle (TA) .

### Removing the D board

- 1** Remove the rear cover of the projector.  
*For details, see “Removing the Upper, Front and Rear Covers” on pages 17 and 18.*
- 2** Loosen the three screws to open the top panel.

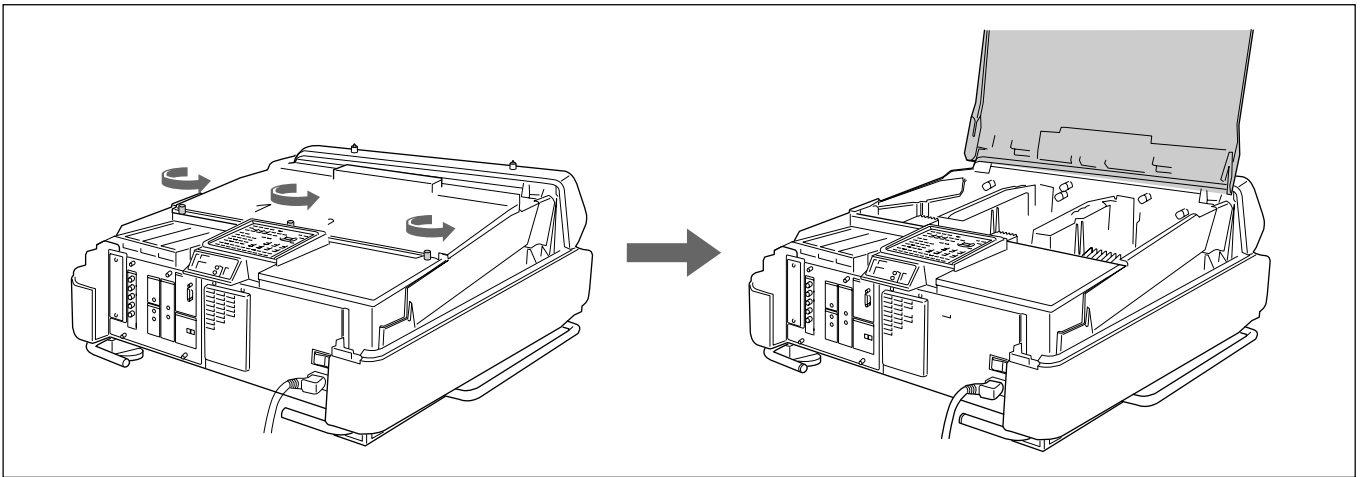

- 3** Pull up the D board while lifting up the card pullers on both ends simultaneously.

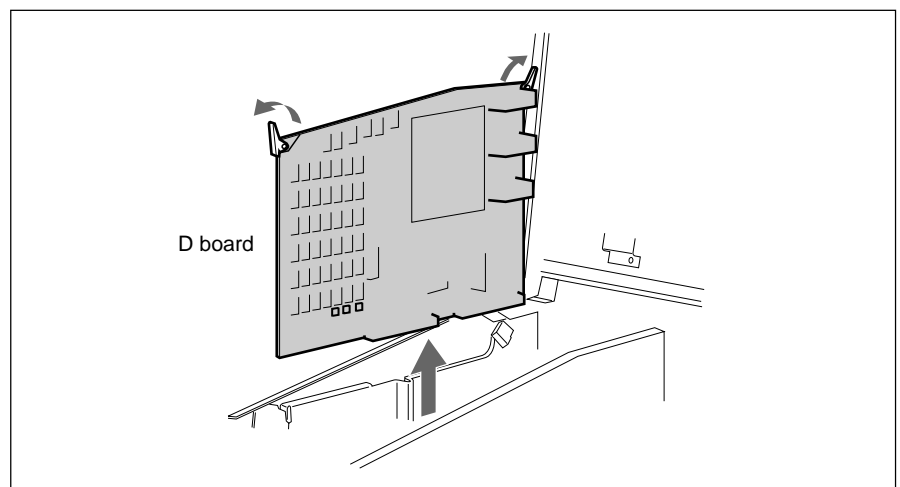

- 4** Switch the S3, S4 and S5 switches on the D board.  
*For details, see “Setting the switches on the D board” on next page.*
- 5** Perform the steps **1** to **4** above in reverse order to replace the D board.

## Setting the switches on the D board

The S3, S4 and S5 switches are set to OFF at the factory. According to the radius of curvature of the curved screen and the optical axis angle, set one of LEVEL 1 to LEVEL 4 of the S3, S4 and S5 switches to ON.

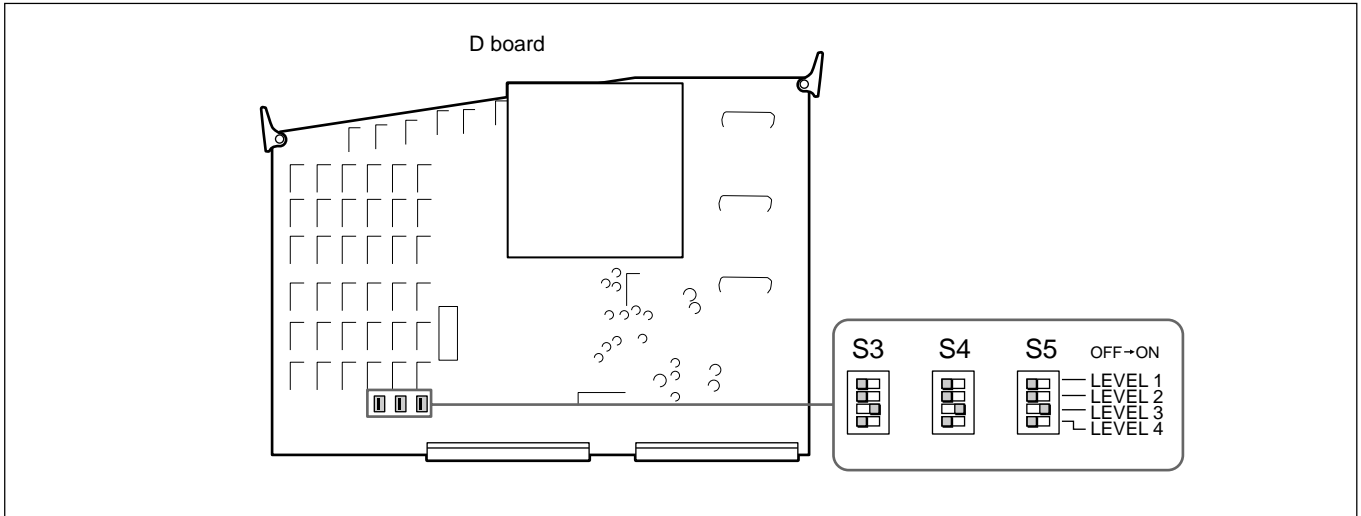

Optical axis angle (TA)	Radius of curvature converted into 100 inch screen (R)				
	2000 mm	2500 mm	3000 mm	5000 mm	10000 mm
15.2°	LEVEL1→ON	LEVEL2→ON	LEVEL3→ON	LEVEL4→ON	LEVEL4→ON
20°	No	LEVEL1→ON	LEVEL2→ON	LEVEL3→ON	LEVEL4→ON
25°	No	No	LEVEL2→ON	LEVEL3→ON	LEVEL4→ON
30°	No	No	LEVEL1→ON	LEVEL3→ON	LEVEL4→ON

No: Installation is impossible.

When your optical axis angle is not mentioned in the table, use the most approximate optical axis angle in the table.

**Example:** To project to the curved screen of 3000 mm radius of curvature at 15.2° optical axis angle, set LEVEL 3 of the S3, S4 and S5 switches to ON.

# Projecting at More Than 15.2° Optical Axis Angle

When using a screen of 100 inches or more, this projector allows up to 30° optical axis angle.

When the optical axis angle (TA) is more than 15.2°, however, adjust the installation measurements so that the projection distance is longer than that with less than 15.2°. The following table indicates the adjustment ratios to the projection distance with 15.2° optical axis angle.

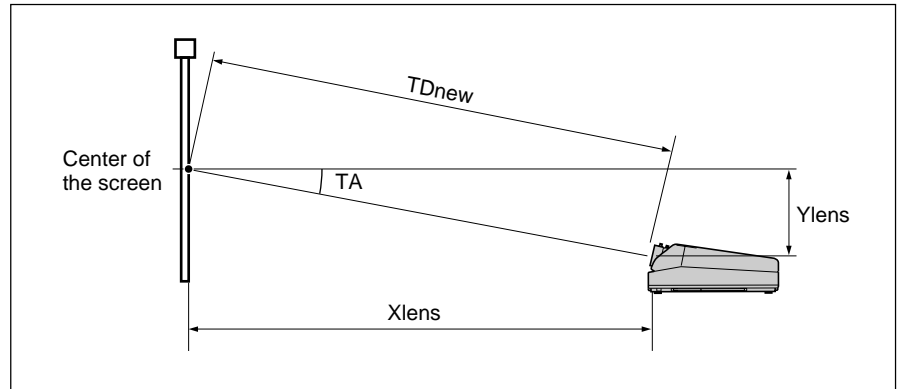

Optical axis angle (TA)	Projection distance (TDnew)
15.2°	100.0 %
20°	102.7 %
25°	105.5 %
30°	108.1 %

If your optical axis angle is not mentioned in the table, calculate the adjustment ratio in proportion.

In addition, if you use a curved screen, apply the installation measurements for the curved screen, referring to “Installing the Curved Screen” on page 124.

**Example:** To project to a 120 inch flat screen at 25° optical axis angle

First, find the projection distance (TD) at 15.2° from the table for a 120 inch screen on page 118. Then adjust the projection distance according to the table above.

Adjusted projection distance:  $TD_{new} = 3316 \times 105.5 (\%) = 3498.4 \text{ (mm)}$

Therefore,

$$X_{lens} = TD_{new} \cdot \cos TA = 3498.4 \cdot \cos 25^\circ = 3171 \text{ (mm)}$$

$$Y_{lens} = TD_{new} \cdot \sin TA = 3498.4 \cdot \sin 25^\circ = 1478 \text{ (mm)}$$



# Installing the VR System

This section explains how to install the VR (Virtual Reality) system that projects images to a curved screen using multiple projectors. Use the following flowchart for designing your VR system.

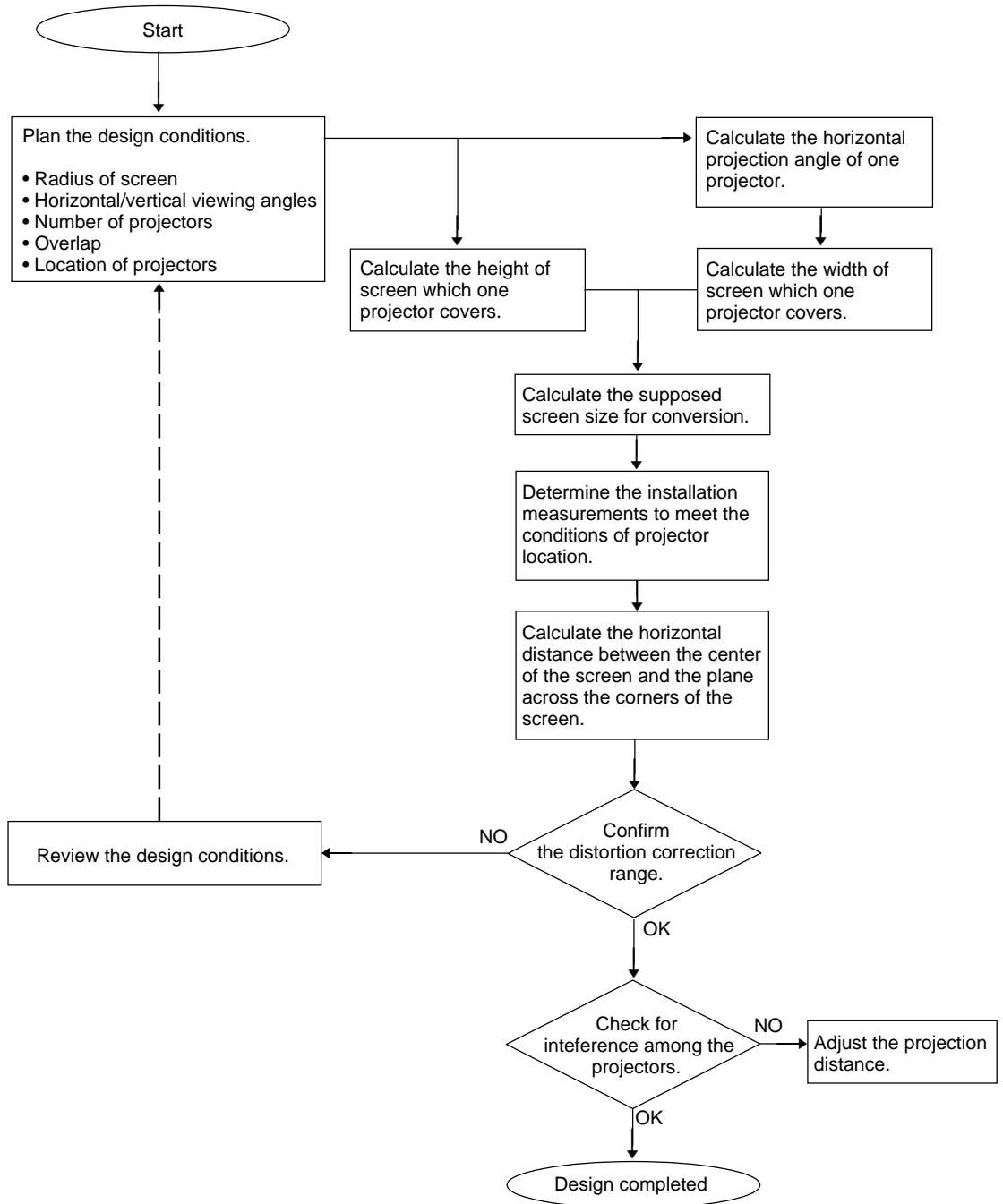

## 1 Planning the design conditions

First, plan the outline of your VR system based on the installation space and the existing designs.

The following values must be identified.

### a Radius of screen

This is the radius of the curved screen to be projected. Determine it by considering the installation space available for the system.

### b Horizontal/vertical viewing angles

These are the viewing angles which the system covers.

The horizontal viewing angle is the angle of the arc which the radius of the screen forms around the center of the radius.

The vertical viewing angle is the angle which the viewer's line of sight forms upward and downward from the horizontal.

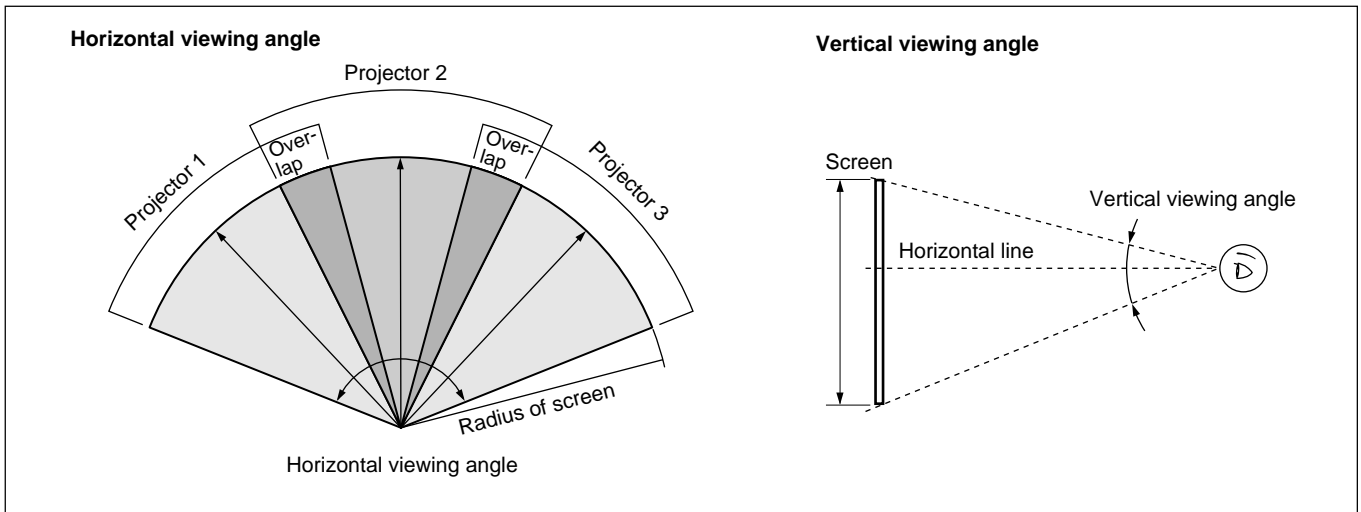

### c Number of projectors

This is the number of projectors to be used in the system. Determine the number by considering the horizontal projection angle which one projector covers and the horizontal viewing angle of the system.

### d Overlap

This is the proportion (%) on which the images from two projectors overlap. It should be considered when you plan to project a seamless image using the edge blending method and so on. We recommend an overlap of approximately 10 %.

### e Installation height of the projector

This is the height at which you install the projector. Determine it by considering the viewer's location and obstructions to the projection.

### Example of system design:

Let's design a system to meet the following conditions:

- a Screen: cylindrical screen of 3000 mm radius with the center of the screen at 1200 mm height
- b Horizontal viewing angle: 150°
- c Number of projectors: 3
- d Overlap: 9.8 %
- e Height of the center of the lens of the projector: 2250 mm

## 2 Calculating the horizontal projection angle of one projector

Using the design conditions on the previous page, you can calculate the horizontal projection angle which one projector covers (Hang) as follows:

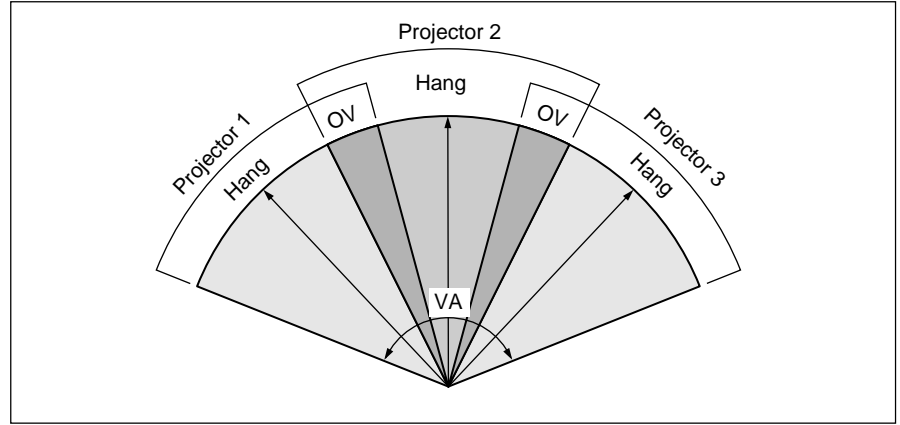

When the horizontal viewing angle of the system is indicated as VA; the overlap as OV (%); and the number of projectors as N, you can calculate the horizontal projection angle (Hang) using the following formula.

- With  $VA < 360^\circ$  (i.e. the image has right and left margins)

$$\text{Hang} = \frac{VA}{N - (N - 1) \cdot (OV/100)}$$

- With  $VA = 360^\circ$  (i.e. the image has no right and left margins)

$$\text{Hang} = \frac{VA}{N \cdot (1 - (OV/100))}$$

If the overlap is not specified by proportion (%), but by angle, use the following formula instead. The overlap angle is indicated as  $OD^\circ$ .

- With  $VA < 360^\circ$  (i.e. the image has right and left margins)

$$\text{Hang} = \frac{VA + (N - 1) \cdot OD}{N}$$

- With  $VA = 360^\circ$  (i.e. the image has no right and left margins)

$$\text{Hang} = \frac{VA + N \cdot OD}{N}$$

The relation between the overlap proportion (%) and the overlap angle is expressed with the following formula.

$$OV = (OD/\text{Hang}) \cdot 100$$

**Example:** When the horizontal viewing angle of the system is  $150^\circ$ , and a cylindrical screen of 3500 mm radius and 3 projectors are used in the system, the horizontal projection angle of one projector (Hang) is

$$\text{Hang} = \frac{150}{3 - 2 \cdot (9.8/100)} = 53.5(^\circ)$$

## 3 Calculating the width of screen which one projector covers

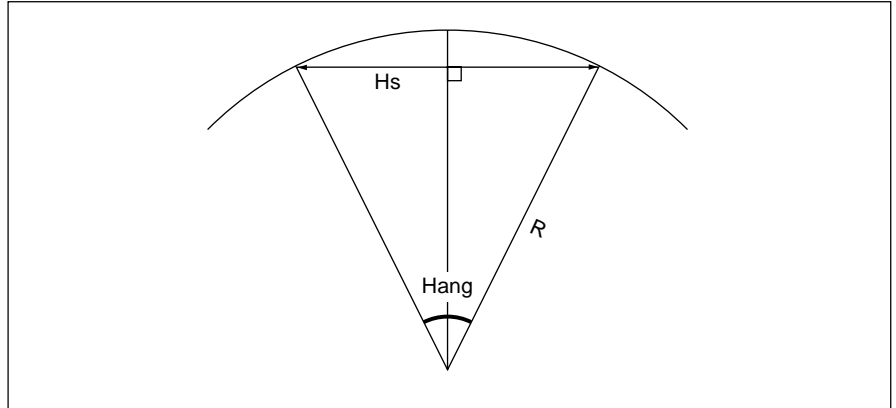

When the radius of screen is indicated as  $R$  and the horizontal projection angle of one projector as  $Hang$ , you can calculate the width of screen ( $H_s$ ) using the following formula:

$$H_s = 2 \cdot R \cdot \sin (Hang/2)$$

**Example:** Using the conditions of the previously mentioned example, the value  $H_s$  is

$$H_s = 2 \cdot 3500 \cdot \sin (53.5/2) = 3151 \text{ (mm)}$$

## 4 Calculating the height of screen which one projector covers

The height of screen may be limited in some cases. If not, you can calculate the height using the angle of the viewer's line of sight.

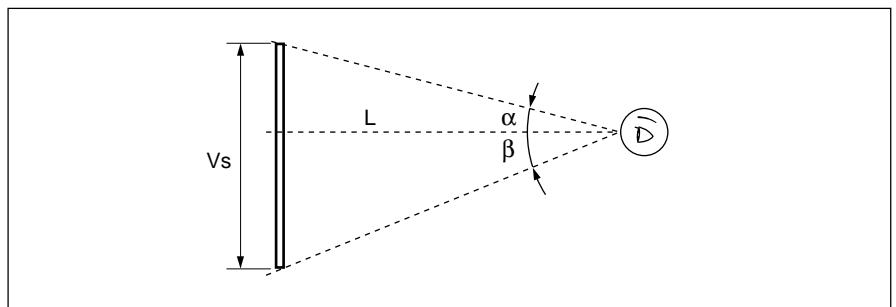

When the horizontal distance between a cylindrical screen and a viewer is indicated as  $L$ ; the upward angle to horizontal as  $\alpha$ ; the downward angle to horizontal as  $\beta$ , you can calculate the height of screen ( $V_s$ ) using the following formula:

$$V_s = L \cdot (\tan \alpha + \tan \beta )$$

**Example:** When the horizontal distance between the screen and the viewer ( $L$ ) is 3500 mm,  $\alpha$  is  $15^\circ$  and  $\beta$  is  $20^\circ$ ,  $V_s$  is

$$V_s = 3500 \cdot (\tan (15) + \tan (20)) = 2212 \text{ (mm)}$$

## 5 Calculating the supposed screen size for conversion

Using the width and height of screen obtained in steps **3** and **4**, you can calculate the supposed screen size whose table exists in “List of the Projection Distance by Angle of Optical Axis.”

As the values in the tables are given for the screen with 4 : 3 aspect ratio (width : height), calculate the supposed screen size based on either the width or height being greater than 4 : 3.

**Example:** When the width of screen is 3151 mm and the height is 2212 mm

As this screen is wider than a 4 : 3 screen, determine the screen size based on the width.

Therefore, the supposed screen size is

$$3151 \cdot (5/4)/25.4 = 155 \text{ (inches)}$$

## 6 Determining the installation measurements to meet the conditions of projector location

This section explains how to determine the installation measurements when the projector is installed at a height that is not obstructed by viewers.

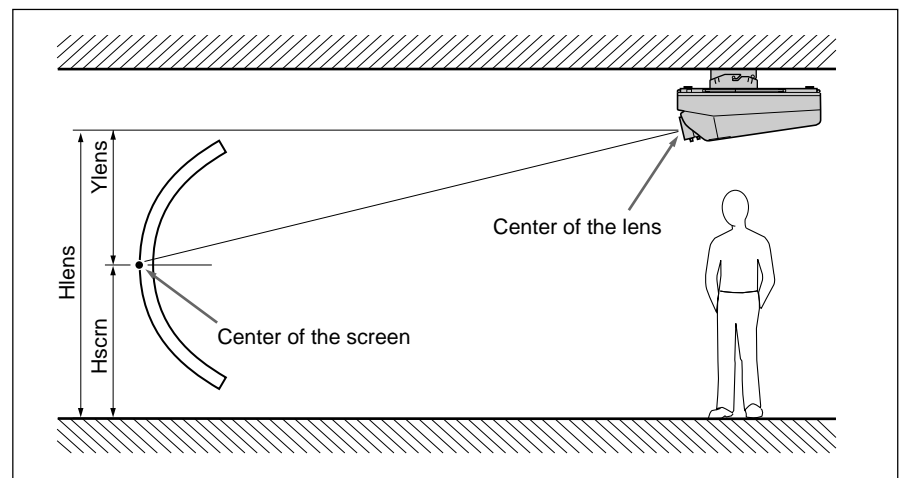

When the height of the center of the screen is indicated as Hscrn, and the height of the center of the lens as Hlens, the relation among Ylens, Hscrn and Hlens is expressed with the following formula.

$$Y_{lens} = H_{lens} - H_{scrn}$$

First calculate the value Ylens using the formula above, and find the obtained value from the tables in “List of the Projection Distance by Angle of Optical Axis.” Then calculate the optical axis angle (TA).

If the supposed screen size obtained in step **5** is not mentioned in the list, calculate the value Ylens by interpolation.

## Installing the VR System

For example, calculate the value  $Y_{lens}$  for a 155 inch screen by interpolating the data for a 150 inch screen and those for a 160 inch screen. The following table shows the interpolated values  $Y_{lens}$  for some optical axis angles.

Optical axis angle (TA)	15.2°	14°	13°
$Y_{lens}$ for 150 inch	1081	994	923
$Y_{lens}$ for 160 inch	1151	1059	983
Interpolated $Y_{lens}$ for 155 inch	1116	1027	953

**Example:** When  $H_{scrn}$  is 1200 mm and  $H_{lens}$  is 2250 mm,  $Y_{lens}$  is

$$Y_{lens} = 2250 - 1200 = 1050 \text{ (mm)}$$

Therefore, TA and  $X_{lens}$  to meet  $Y_{lens}$  of 1050 mm are:

$$TA = \frac{(1050 - 1027)}{(1116 - 1027)} \cdot (15.2 - 14) + 14 = 14.31(^{\circ})$$

$$X_{lens} = 1050 / \tan (14.31) = 4116 \text{ (mm)}$$

### 7 Calculating the horizontal distance between the center of the screen and the plane across the corners of the screen

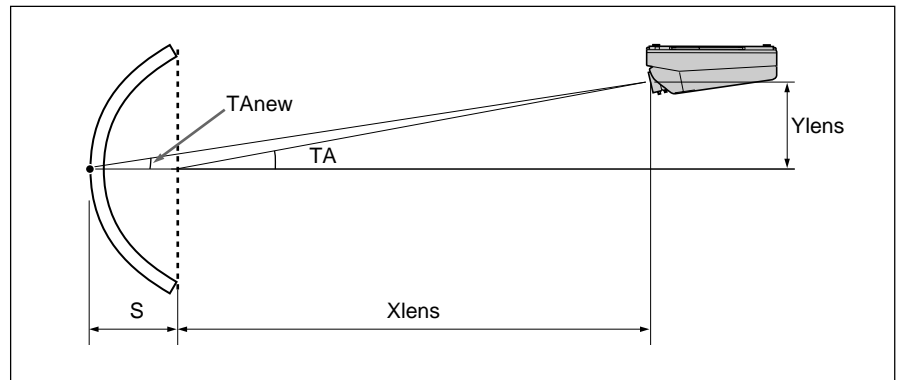

When the radius of screen is indicated as  $R$  and the height and width of the screen as  $V_s$  and  $H_s$  respectively, you can calculate the horizontal distance between the center of the screen and the plane across the corners of the screen ( $S$ ) using the following formulas.

- With a spherical screen

$$S = R - \sqrt{R^2 - (H_s/2)^2 - (V_s/2)^2}$$

- With a cylindrical screen

$$S = R - \sqrt{R^2 - (H_s/2)^2}$$

---

**Example:** When a cylindrical screen is used, R is 3500 mm and Hs is 3151 mm, the horizontal distance S is

$$S = 3500 - \sqrt{(3500)^2 - (3151/2)^2} = 375 \text{ (mm)}$$

Now, all the necessary installation conditions are identified. Finally, calculate the installation measurements using the formulas mentioned in “Installing the Curved Screen” on page 124.

That is,

Horizontal projection distance:

$$X_{\text{lens}} + S = 4116 + 375 = 4491 \text{ (mm)}$$

Optical axis angle:

$$T_{\text{Anew}} = \tan^{-1} \left( \frac{Y_{\text{lens}}}{X_{\text{lens}} + S} \right) = \tan^{-1} \left( \frac{1050}{4491} \right) = 13.5(^{\circ})$$

---

## 8 Confirming the distortion correction range

The S3, S4 and S5 switches on the D board correct the geometrical distortion caused by the curve of the screen and the optical axis angle. For details, see the table in “Setting the Switches on the D Board” (page 129). The radii mentioned in that table are for a 100 inch screen. Therefore, you need to convert your screen size and radius into a 100 inch screen radius before determining if the distortion caused by your system can be corrected with the switches.

**Example:** When the radius of screen (R) is 3500 mm and the screen size (Ds) is 155 inches, the radius converted into a 100 inch screen is

$$R \cdot (100/Ds) = 3500 \cdot (100/155) = 2258 \text{ (mm)}$$

When the optical axis angle is  $14.31^{\circ}$  (that is, less than  $15.2^{\circ}$ ) as calculated in step **6**, the switches can correct the distortion of a screen with a radius of 2000 mm or more according to the table on page 129.

If your conditions are not within the distortion correction range, go back to the start of the examination and review the design conditions such as the viewing angles, the radius of screen and the number of projectors.

## 9 Checking for interference among the projectors

Finally, confirm that the projectors do not obstruct each other when they are actually installed.

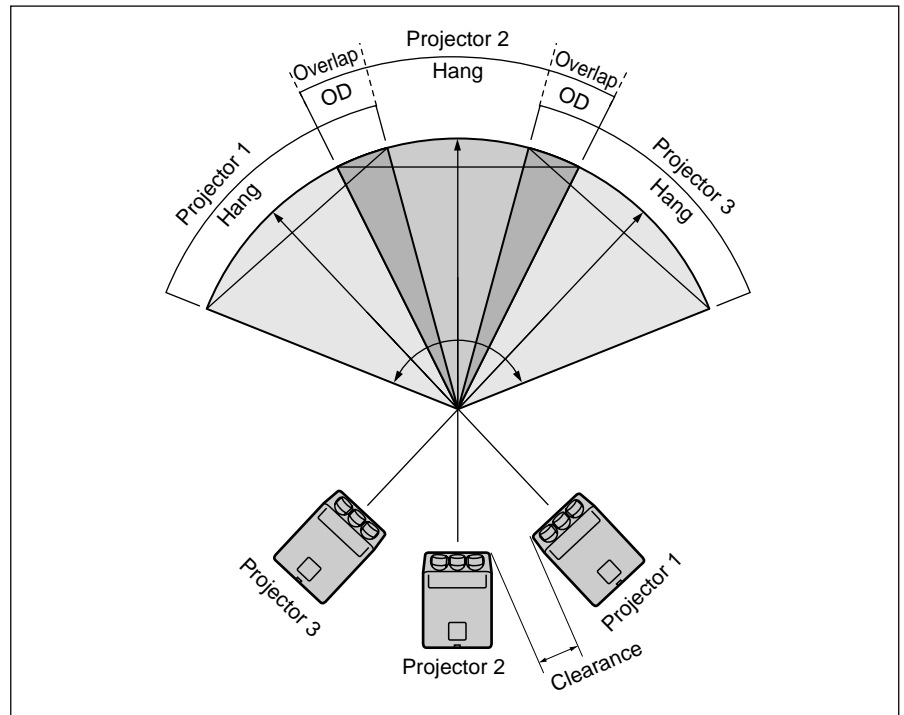

The projectors are installed at positions rotated around the center of the screen radius, at an angle of the horizontal angle (Hang) minus overlap angle (OD) apart from each other.

As Hang is  $53.5^\circ$  and OD is  $0.1 \cdot 53.5 = 5.35^\circ$  in the example we have used, the rotation angle is

$$\text{Hang} - \text{OD} = 53.5 - 5.35 = 48.15^\circ$$

If there is clearance between the projectors, the installation is successful. If the projectors obstruct each other, extend the projection distance or review the design conditions.

The procedure to examine the installation of the VR system is now completed.



## A

- ABG (Automatic Background) mode 50
- ABL LINK menu 56
- Adjusting
  - AQP/DQP 70
  - black level 105
  - blanking 101, 104
  - blue centering 96
  - blue focus 73
  - blue registration 96
  - CRT conversion angle 21
  - each input signal fine 98
  - flapping of lens 68
  - green centering 78
  - green focus 66
  - green KEY and PIN 83
  - green KEY BALANCE and PIN BALANCE 85
  - green registration 78
  - green SIZE and LIN 79
  - green SKEW and BOW 81
  - magnetic focus 70
  - magnetic focus fine 98, 102
  - picture quality 112
  - red centering 87
  - red focus 72
  - red KEY and PIN 91
  - red KEY BALANCE and PIN BALANCE 93
  - red registration 87
  - red SIZE and LIN 87
  - red SKEW and BOW 89
  - red ZONE 95
  - registration fine 100, 102
  - RGB input signal 102
  - RGB SHIFT 48, 100, 103
  - RGB SIZE 48, 100, 103
  - video input signal 98
  - video picture size/shift 100
  - uniformity 55
  - white balance 105
  - white level 106
  - AQP 70

All white mode 54, 74

## B

- Basic registration data 108
- Blanking 48, 101, 104
- 5BNC mode 29, 30, 51

## C

- Carrying the projector 8
- Changing
  - initialization period 113
  - language 50
  - picture luminance (clamp setting) 46
  - polarity 19
- Clamp setting 46
- Connecting
  - multiple projectors 31
  - remote commander to the projector 38
  - to external equipment directly 27
  - using the optional board or switcher 28 to 31
- CRT timer 54
- Curved screen 124

## D

- Data reset 109
- Direct power on 53
- DQP 70
- Dynamic picture 45, 112

## E

- Error codes 115
- Error code window 115
- Expert mode
  - exiting 60
  - INPUT MEM. OPTION menu 57
  - setting 60

## F,G

- Factory data preset 108
- Frequency sensitivity 52, 60

## H

- Handle release levers 8

## I, J, K

- Index number 24, 51
- INPUT INFO menu 51
- INPUT MEM. OPTION menu 52, 57
- Input memory number 52, 58
  - deleting 59
  - loading 58
  - saving 58
- INPUT SETTING menu 46
- Installation
  - ceiling installation 11
  - diagrams 5
  - floor installation for front projection 9
  - floor installation for rear projection 13
  - procedures 4
- Installing
  - batteries to the remote commander 37
  - optional interface board 28

## L

- Location and Function of Connectors 23

## M

- Memory
  - architecture 108
  - structure 107
- Memory protect 59
- Menu operation 42

## N

- Notes on screen
  - available types of screen 16
  - screen size 15
  - with an aspect ratio other than 4:3 15

## O

- 128 data reset 109
- Opening the upper cover 17
- Optical axis angle 13, 128
- OPTION menu 57

## **P, Q**

- PIC CTRL menu 44
- PIC. ORBITING 54
- Picture muting 49
- Polarity connector 19
- Polarity switch 19
- Power on delay 56
- Power saving 50
- Protecting the setting 111

## **R**

- Remote commander
  - battery installation 37
  - location and function of control 39
  - preparation 36
- Removing front and rear covers 18
- Resetting
  - data 109
  - standard data to the factory preset levels 110

## **S**

- Saving the data
  - memory architecture 108
  - memory structure 107
  - saving the standard registration data 97
- Service adjustment mode 36
- Service data reset 109
- SERVICE SETTING menu 53
- SET INFO menu 54
- SET SETTING menu 49
- Setting
  - color system 45
  - color temperature 46
  - component format 47
  - dynamic picture 45, 112
  - remote control detector 50
  - SET UP level 45
  - sync signal 47
  - vertical shift 48
  - white balance 105
- Status 49

## **T**

- Test patterns 51, 61
- Tool 17

## **U**

- UNIFORMITY menu 55
- Using
  - handles 8
  - menu 42
- User mode 60, 111

## **V**

- Variable range of optical axis angle 116
- Ventilation hole 5
- VR system 129

## **W**

- What is linked ABL function? 32
- What is the AQP/DQP adjustment? 70
- When the screen size is not mentioned in the tables 10



---

Sony **on**line

<http://www.world.sony.com/>

Printed on recycled paper