

Presentation™ Series

HD Projection Display Installation and Setup Guide for System Installer

Model
PR0900X

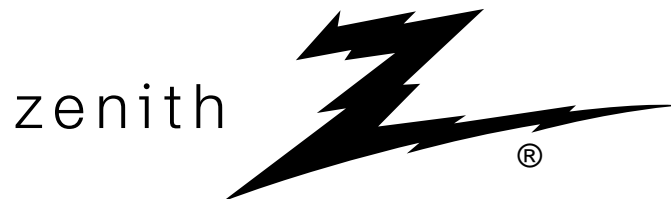
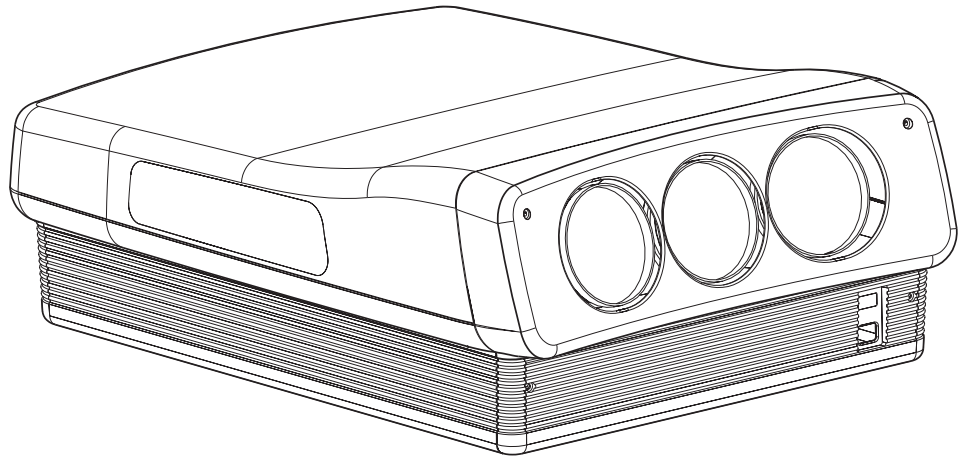

SAFETY WARNINGS

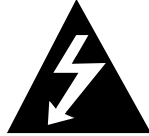

WARNING
RISK OF ELECTRIC SHOCK
DO NOT OPEN



WARNING:

TO REDUCE THE RISK OF ELECTRIC SHOCK DO NOT REMOVE COVER (OR BACK). NO USER SERVICEABLE PARTS INSIDE.
REFER SERVICING TO QUALIFIED SERVICE PERSONNEL.



The lightning flash with arrowhead symbol, within an equilateral triangle, is intended to alert the user to the presence of uninsulated "dangerous voltage" within the product's enclosure that may be of sufficient magnitude to constitute a risk of electric shock to persons.



The exclamation point within an equilateral triangle is intended to alert the user to the presence of important operating and maintenance (servicing) instructions in the literature accompanying the appliance.

WARNING:

TO PREVENT FIRE OR SHOCK HAZARDS, DO NOT EXPOSE THIS PRODUCT TO RAIN OR MOISTURE.

NOTE TO CABLE/TV INSTALLER:

This reminder is provided to call the cable TV system installer's attention to Article 820-40 of the National Electric Code (U.S.A.). The code provides guidelines for proper grounding and, in particular, specifies that the cable ground shall be connected to the grounding system of the building, as close to the point of the cable entry as practical.

REGULATORY INFORMATION:

This equipment has been tested and found to comply with the limits for a Class B digital device, pursuant to Part 15 of the FCC Rules. These limits are designed to provide reasonable protection against harmful interference when the equipment is operated in a residential installation. This equipment generates, uses and can radiate radio frequency energy and, if not installed and used in accordance with the instruction manual, may cause harmful interference to radio communications. However, there is no guarantee that interference will not occur in a particular installation. If this equipment does cause harmful interference to radio or television reception, which can be determined by turning the equipment off and on, the user is encouraged to try to correct the interference by one or more of the following measures:

- Reorient or relocate the receiving antenna.
- Increase the separation between the equipment and receiver.
- Connect the equipment into an outlet on a circuit different from that to which the receiver is connected.
- Consult the dealer or an experienced radio/TV technician for help.

CAUTION:

Do not attempt to modify this product in any way (except as noted herein) without written authorization from Zenith Electronics Corporation. Unauthorized modification could void the user's authority to operate this product.

CONTENTS

Safety Warnings		
Safety Warnings	2	
Installation Overview		
Installer's Experience Level	4	
Installation Considerations	4	
Power Cord Requirements	4	
Specifications		
Specifications	5	
Standard Connections		
Connecting Computer Video Sources	6	
Connecting Video and S-Video Sources	6	
Connector Pin Wiring Reference	7	
Connection / Control Panel	8	
Selecting Input Source	8	
Remote Control		
Battery Installation	9	
Choosing the Setup Function	9	
Product Overview		
Product Overview	10	
Monitor Cabinet Removal		10
Monitor Rear View		11
Monitor Top/ Inside View		12
Setup		
Setup Remote Control Key Functions		13
Setup Mode Notes and Cautions		14
Specifications for RGB Sync Inputs		15
Notes		16
Screen Size Selection		17
Setup and Alignment Procedure		
Procedure Overview		18
I. Installation Prerequisites		18
II. System Check and Physical Setup		18
Setup Reference Illustrations		19
Physical Setup		20
III. Preliminary Alignment Setup		22
Geometry Convergence		25
Convergence Setup Controls		26
Convergence of Red and Blue onto Green		27
Notes		28

PLACEMENT CONSIDERATIONS

Room Light

Ideally, the PRO900X should be placed in a low-light environment. Picture quality and the ability to see the projected images are adversely affected by bright-light conditions.

Placement

Your PRO900X is shipped from the factory to provide an image with an 80" width as a ceiling-mounted front projector. To ensure proper placement of the unit or to change the size of the projection image, refer to the "Physical Setup" section.

Viewing Surface

We recommend a good quality screen having a matte white finish, which measures 80" in width (or more) diagonally. Contact your local dealer for assistance in purchasing an appropriate screen.

Note: Use of a projection screen designed for a single light source projection system may result in significant side-to-side color distortion.

Note to Installer

The purpose of this installation guide is to provide general guidelines for the proper installation and set up of the PRO900X. Actual operation of the unit is described in the separately supplied Operating Guide and Warranty.

This guide has been prepared for properly trained installers.

INSTALLATION OVERVIEW

Installer's Experience Level



The PRO900X is a sophisticated Entertainment Machine™. In addition to making the necessary connections, installation will most likely require a series of adjustments to ensure the projected image is not distorted. If these adjustments are not accurate, the operation of the PRO900X could be adversely affected. For this reason, installation and setup should be performed by a qualified service person and should conform to all local codes. The installer must also adhere to the pertinent Articles of the National Electrical Code (NEC), pertinent Regulations of the Federal Communications Commission (FCC), and all relevant codes of local regulating agencies.

Installation Considerations

Before you install the PRO900X...



Ventilation -- Proper ventilation keeps the PRO900X running cool. Air circulates through perforations on the sides of the cabinet. Do not block these vents or you will shorten the life of the PRO900X.



Power Cord -- The PRO900X has a three-wire grounding-type plug having a third (grounding) pin. This plug will only fit into a grounding-type power outlet.

This is a safety feature. If you are unable to insert the plug into the outlet, contact an electrician to replace the obsolete outlet. Do not defeat the safety purpose of the grounding-type plug.



Power Source -- The PRO900X is designed to operate on normal household current, 120 volt 60 Hertz AC or 230 volt 50/60 Hertz AC. Do not attempt to operate it on DC current.

The PRO900X is configured at the factory for 120 volt, 60 Hz operation. A service adjustment is necessary to permit the unit to operate on 230 volt, 50/60 Hz. See Changing From 120 VAC To 230 VAC in the Setup and Alignment section for details.

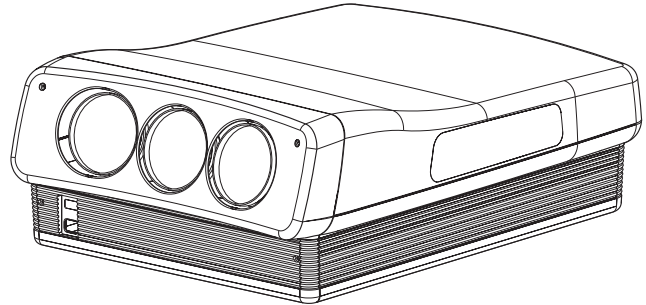

National Power Cord Requirements U.S. / Canada

- The power cord must be UL listed and CSA certified.
- The minimum specifications for the power cord are as follows: No. 18 AWG, Type SV or SJ, 3 conductor.
- The power cord must have a rated current capacity of at least 10 amperes.
- The attachment plug must be an earth-grounding type with a NEMA 5-15P (15A, 125V) or NEMA 6-15P (15A, 250V) configuration.

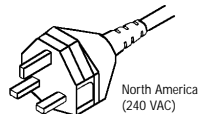
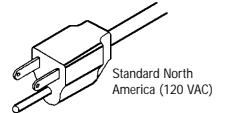

Other Countries

- The cord set fittings must bear the certification mark of the agency responsible for evaluation in a specific country. Acceptable agencies include the following:

BSI (United Kingdom)	Nemko (Norway)
CEBEC (Belgium)	OVE (Austria)
DEMKO (Denmark)	SEMKO (Sweden)
EANSW (Australia)	SEV (Switzerland)
SETI (Finland)	UTE (France)
IMQ (Italy)	VDE (Germany)
KEMA (The Netherlands)	MITI (Japan)

- The flexible cord must be of a HAR (harmonized) type H05VV-F 3-conductor cord with a minimum conductor size of .03 square inches (1.0 square millimeter).
- The cord set must have a current capacity of at least 10 amperes and a nominal voltage rating of 125 or 250 VAC, as required by the specific country's power system.

SPECIFICATIONS

PRO900X

Note: Specifications are subject to change without prior notice.

Optical

PROJECTION SYSTEM — CRT; 7-inch High Performance Liquid Cooled Tubes, 5-inch active phosphor area, 90 degree deflection angle, Super Oxide Cathodes.

LENSES — High resolution color corrected multi-layered coating hybrid lens system. f1.03 Aperature.

LIGHT OUTPUT — 700 Lumens peak light output.

CONVERGENCE — Digitally controlled analog with 10 factory pre-set options, 5 customer memory locations plus a copy function feature.

CONVERGENCE LIMITS — Less than 0.2% of vertical height.

SELF-GENERATED SET UP PATTERNS — Cross Hatch (coarse and fine), convergence color pattern, static adjust.

SCHIEMPFLUG FOCUS — For edge focusing.

Inputs

RGB INPUTS — 5 - BNC analog (RGB H/V) with full VGA and VESA Super VGA tracking compatibility.

COMPOSITE VIDEO INPUT — 1.0 Vp-p, 75 ohm (BNC jack), loop through (NTSC 3.58, NTSC 4.43, PAL M/N, PAL B/G).

S-VIDEO INPUT — Y: 1.0 Vp-p 75 ohm; C: 0.28 Vp-p color burst level (via mini DIN) connector.

DATA COMMUNICATIONS PORT — RS232 serial port.

POWER INPUT — Dual-range power supply 90-137 Vac, 180-264 Vac, 47-63 Hz.

Video Features

- Three-dimensional Digital Comb Filter.
- Two-dimensional Picture Sharpness Circuitry.
- Digital Dynamic Video Noise Reduction.
- Color Transient Improvement.
- Black Level Expansion.
- Auto Flesh Tone Correction.
- Video Edge Enhancement.
- Color Noise Reduction.
- Advanced Video DSP with 5 megabit memory.
- Extra Wide-band Video Amplifiers.
- High Resolution AKB with programmable white balance control.
- Picture setup via source selection.
- World Wide Multi-standard Video System (PAL M/N, PAL B/G, NTSC).
- Aspect Ratio Correction.
- Multi-Frequency, Multi-Format High Definition System (15 to 50 kHz, 75 MHz dot clock).
- Addressability via IR for multiple projection unit applications.
- On-Screen Display capable of 13 x 32 character display resolution.

General

HORIZONTAL SCAN FREQUENCY — 15.0-50.0 kHz.

VERTICAL SCAN FREQUENCY — 40.0 - 100 Hz.

RETRACE TIME — Horizontal: < 3.5 μ S (15.0 - 50.0 kHz).
Vertical: 450 μ S (40.0 - 100 Hz).

BANDWIDTH — 37.5 MHZ (-3dB).

RGB RESOLUTION — 1920 x 1080 (interlace).

VIDEO RESOLUTION — 800 TV Lines.

SIZE ADJUSTABLE — 48 - 192 inches wide.

SCREEN CONFIGURATION — Front or rear, floor or ceiling mount, with simple scan reversal.

COLOR BALANCE — Four user selectable settings:

3200/6500/9300/Custom.

HIGH VOLTAGE — 32 kV.

POWER CONSUMPTION — 600 Watts max.

AC POWER CORD — 3 meters.

WEIGHT — 43.13 kg / 95 lbs.

ENVIRONMENT — Operating Temperature: 0 to 40° C (degrees);

Humidity: 0 to 90 percent non-condensing;

Storage: 10 to 50° C (degrees)

SAFETY AND REGULATION —

- UL: Complies with UL 1950.
- CSA: Complies with CSA C22.2 No. 950.
- FCC: Complies with FCC Class B Regulations.
- European: CE Mark. Complies with IEC 950.
- DHHS: Complies with X-Ray Emission Regulations.
- NOM: Complies with Mexico Standards.

MECHANICAL DIMENSIONS — 12.90 inches (H), 25.75 inches (W), 33.28 inches (D).

REMOTE CONTROL SYSTEM — Two IR receivers for front and rear remote access. Installer's remote provides full control of menus and convergence. Operators remote is point and click trackball.

Formats Supported	
NTSC	3.58
NTSC	4.43
PAL	M, N, B, G.
VGA	IBM Standard
SVGA	VESA Standard, 1024 x 768
Mac II	640 x 480, 35kHz
Grand Alliance	HDTV Formats. 1280 x 720, progressive, 16 x 9 aspect ratio. 1920 x 1080, interlaced, 16 x 9 aspect ratio, per SMPTE specification, tri-level sync.

STANDARD CONNECTIONS

CONNECTING COMPUTER VIDEO SOURCES

Connect a video source such as a computer: PC, Laptop, or Notebook type.

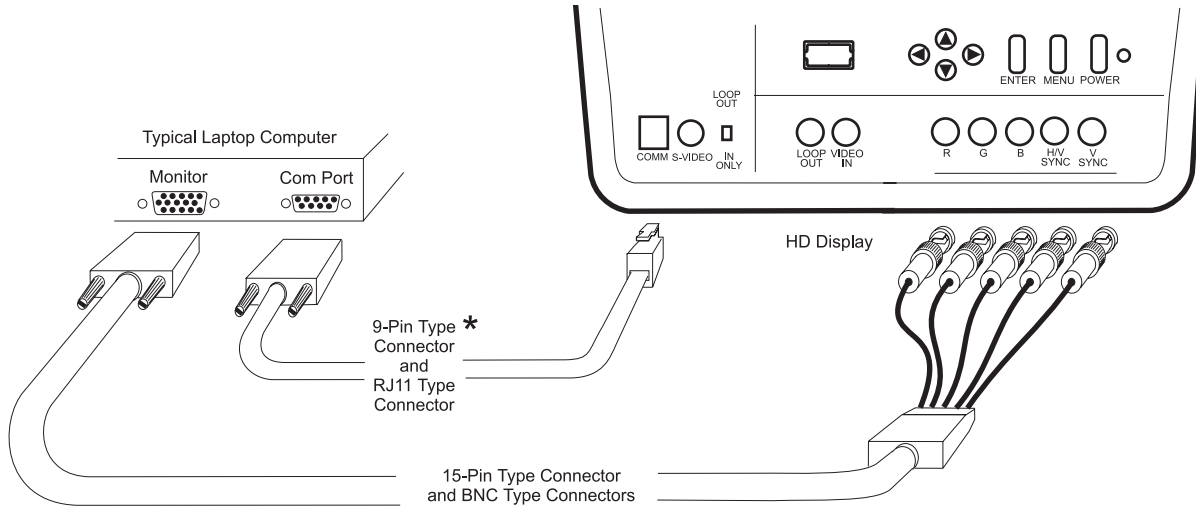

To hook up a laptop or computer, use a cable with a 15-pin D-type connector on one end and BNC connectors on the other end.

Note: Any special adapters, cables, or connectors shown are not provided with the PRO900X. See your computer dealer for your special requirements.

CONNECTING VIDEO AND S-VIDEO SOURCES

Connect video sources with a tuner, (VCR) or other video sources such as a DVD player or satellite receiver.

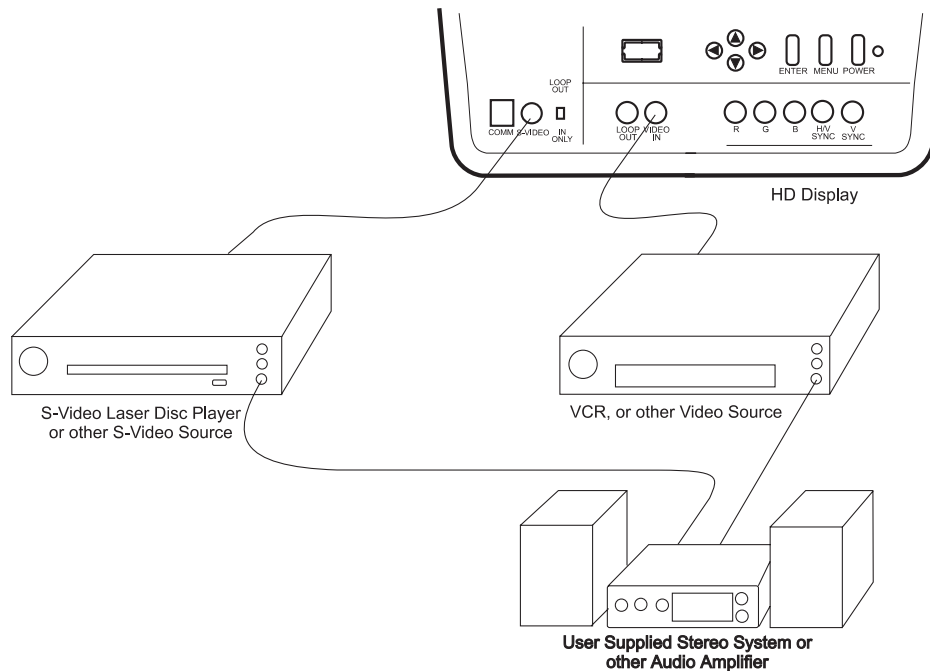

To hook up a VCR, DVD player, or other video source, use standard video connectors as needed. Connect the video source to the Video In jack on the PRO900X. If the video source has an S-Video connector, then connect to the S-Video jack on the PRO900X.

Notes: For audio capability, connect your Video sources' Audio output to a separate audio amplifier like a stereo system; no audio capability is provided with the PRO900X. Use cables and adapters with the connector types and jacks available on the video source.

STANDARD CONNECTIONS

CONNECTOR PIN WIRING REFERENCE

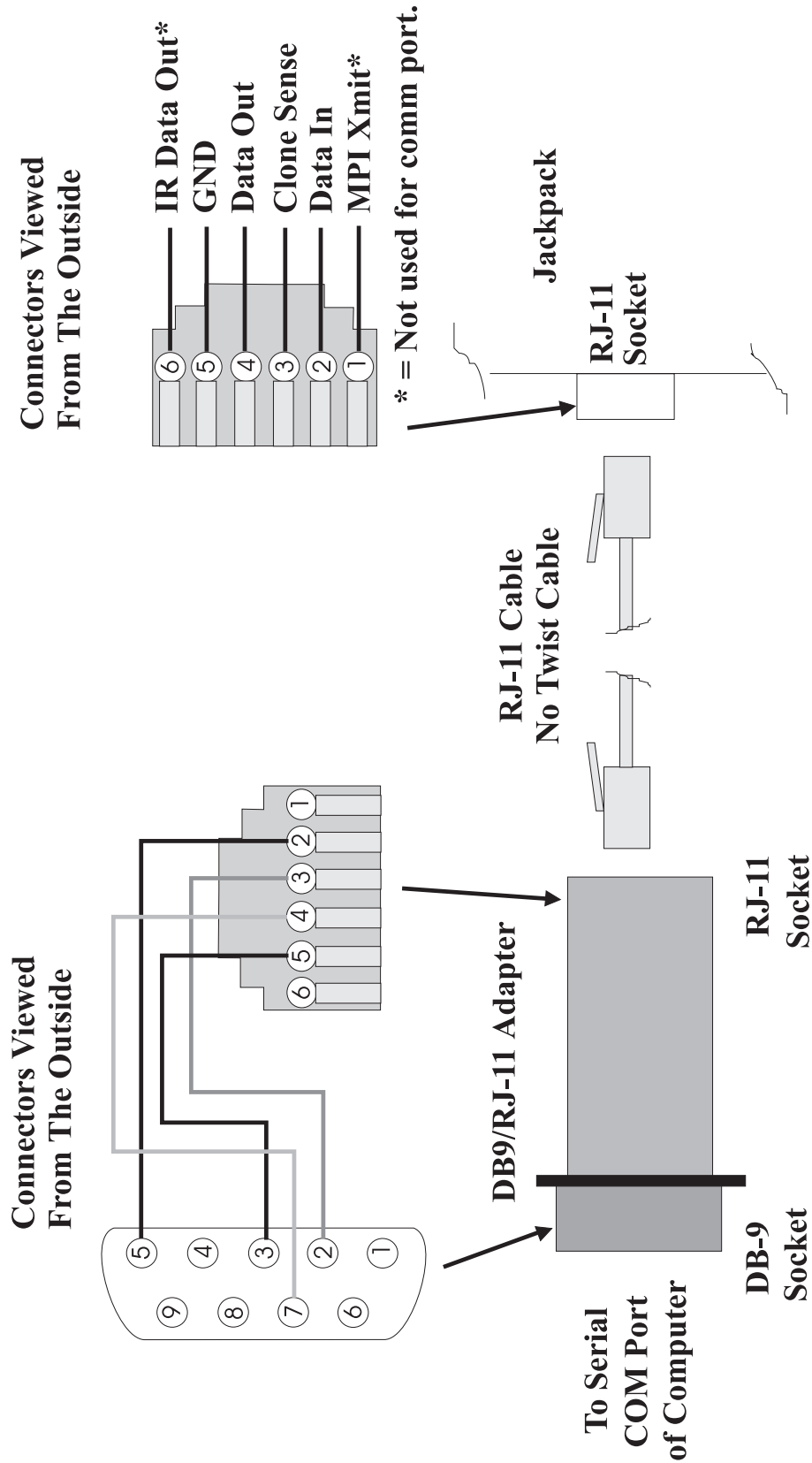

1. This connection is to a serial "COM Port" of a computer.
2. The data format is 1200 baud, no parity, 8 bit, and 1 stop bit.
3. The serial COM Port used must be setup for the correct data configuration.

CONNECTIONS / CONTROL PANEL

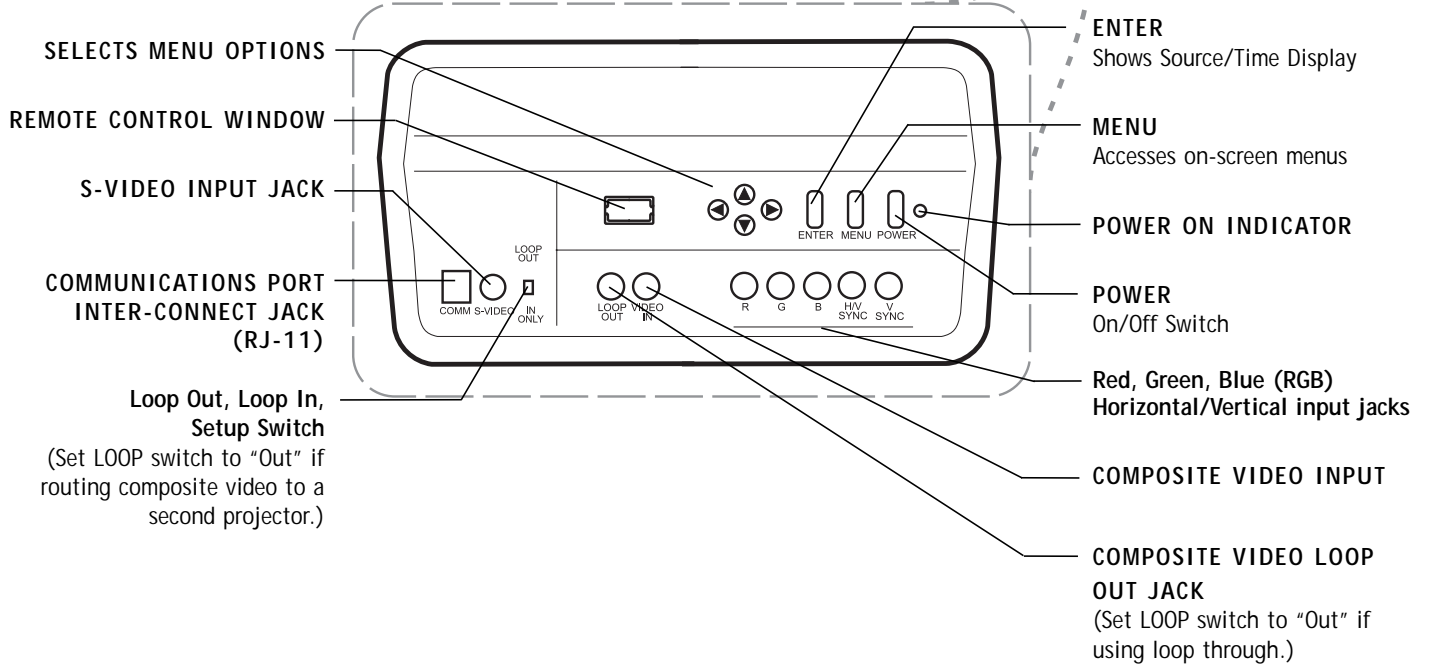
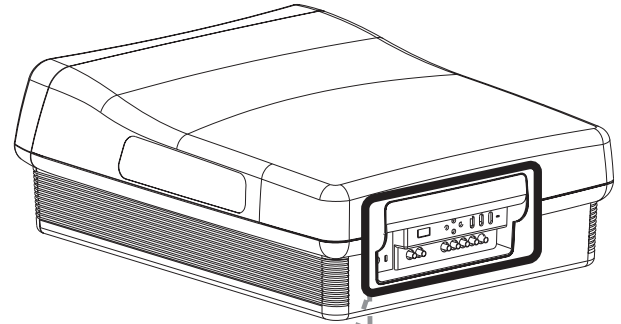
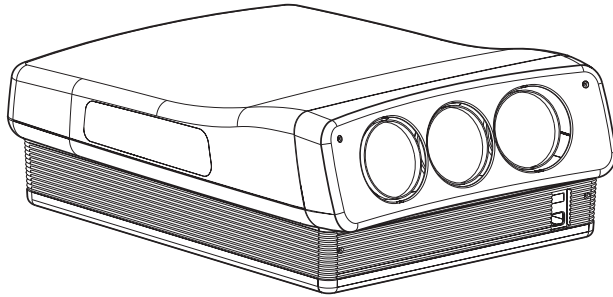

Selecting the Input Source

The type of input signal determines which source is being viewed. Use the Source Menu to select the source you want to view. The options in the menu correspond to the connectors on the connection panel.

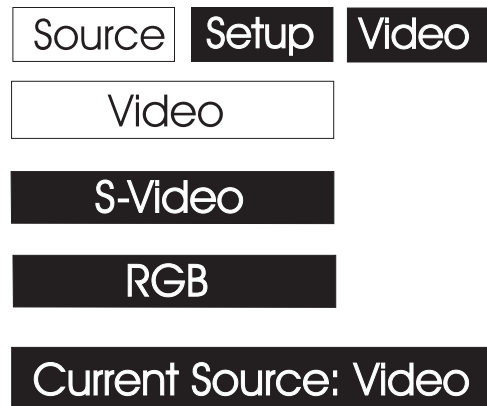

REMOTE CONTROL

REMOTE CONTROL MBR3470T

The MBR3470T remote control is used specifically for servicing and setup adjustment. It provides the special functions needed for geometry, convergence, and system setup that other remotes cannot perform.

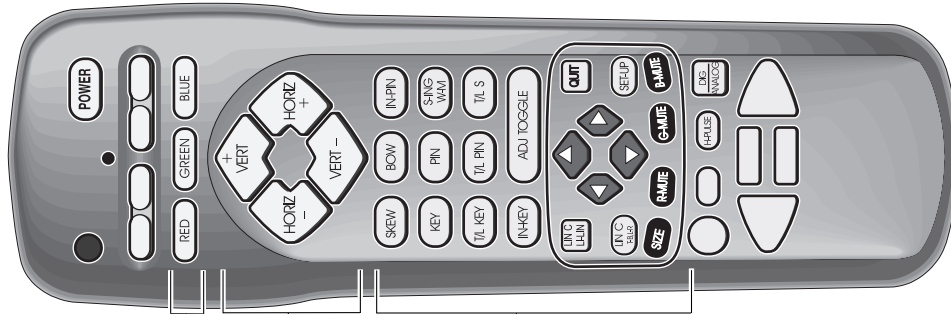

Red, Green, Blue
Selects formats, sets Floor/Ceiling or a specific color convergence.

Vertical and Horizontal
Adjusts selected geometry/convergence characteristics.

Adjustment Select Keys
Adjusts selected geometry/convergence characteristics.

BATTERY INSTALLATION

Batteries are provided, but they must be installed before using the remote control. When it no longer functions normally, or when it loses memory, replace the batteries with two high-quality, alkaline, size AAA batteries.

To Install the Batteries

1. Open the battery compartment by pressing in on the tab and lifting the cover off.
2. Place the batteries into the compartment according to the markings shown in the compartment.
3. Replace the battery compartment cover.

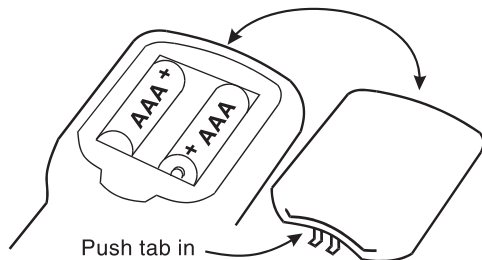

Notes

- Do not place heavy objects on top of the remote control keys. Prolonged unintentional operation of the remote shortens the usable life of the batteries.
- Remove the batteries if the remote control will not be used for a month or more.
- The remote manufacturer is not responsible for damage caused by battery leakage.

CHOOSING THE SETUP FUNCTION

Press SETUP to set the remote control in "setup" mode. In the setup mode, you have the following choice of which setup functions to perform:

Geometry Convergence -- Press SETUP, then RED.

Single Color Convergence -- Press SETUP, then RED, and a color key (Red, Green or Blue) to select color to converge.

Forced Signal Formats -- Press SETUP, then GREEN.

Ceiling/Floor Select -- Press SETUP, then BLUE.

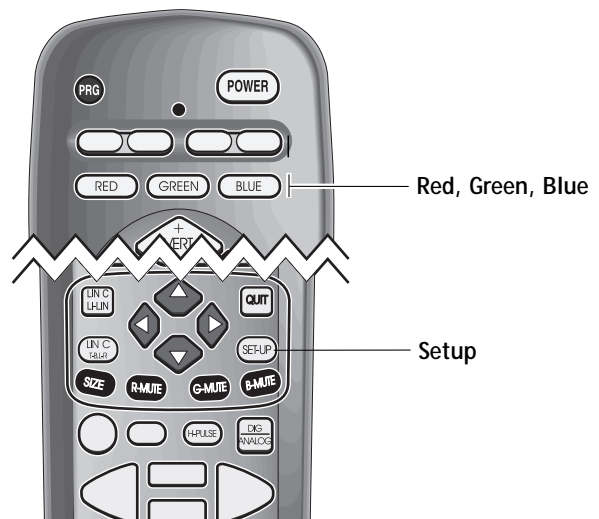

PRODUCT OVERVIEW

The PRO900X HD Projection Display system is a high resolution multiple signal format display monitor. It uses 7" high performance liquid cooled CRTs. Each CRT has a 5" active phosphor area and a 90 degree deflection angle. The CRTs use high-resolution color corrected multi-layered hybrid lens assemblies.

Horizontal scan frequency is from 15 to 50 KHz. Vertical scan frequency is from 40 to 100 Hz. Video system signal bandwidth is 35 MHz. The projected display diagonal size (4:3 aspect ratio) is adjustable from 60" to 240". Supported signal formats include NTSC (3.58 and 4.43), PAL (M,N,B, and G), VGA, SVGS, Mac II, and Grand Alliance HDTV. Signal input options include 5 BNC connectors (R,G,B,V,H), composite video, S-Video (Y-C), and an RS232 serial data port. The IR control format is addressable (0 - 99) for use with multiple unit installations. Each PRO900X comes with a Universal customer remote control and a service/alignment 5-function MBR3470 remote control.

From the factory, the PRO900X comes aligned for a 80" wide display. The preset projection distance is 96 3/8" and configured for a ceiling mount. You may customize the setup to be floor or ceiling mounted and rear or front projected. Refer to the setup section before attempting an installation.

The convergence system is a digital controlled analog system with 10 signal format preset and 5 customer option memory locations. The preset format memory locations

cannot be altered in the field. Each preset format has a custom memory location to store customized setup data. Each customized setup has a separated memory location for each aspect ratio (4 X 3, letter box, compressed, and 16 X 9). You must set up and converge the system for each aspect ratio that will be used. The five customer memory locations are for signal formats that do not match the ten factory preset signal formats. There is also the option to copy the stored format data from one memory location to another. This allows faster setup when several similar formats are used. Internally generated signal patterns also aid with setup of convergence. The internal pattern generator may sync from the internally preset signal formats or it will sync from an external signal source. This is helpful for on-site full convergence or just a touch up. You must use the customer's signal source to perform blanking and phase adjustments.

The PRO900X cabinet is comprised of three pieces. Removal of the case allows full maintenance access to the systems electronic and mechanical assemblies. Front and rear mounted IR detector assemblies allow almost no interference to IR control. There are adjustable (and removable) feet on the bottom of the case.

CABINET REMOVAL

Note the location of the screws which need to be removed to allow access to the components.



Caution:

Disconnect the PRO900X from power before attempting to remove the cabinet.

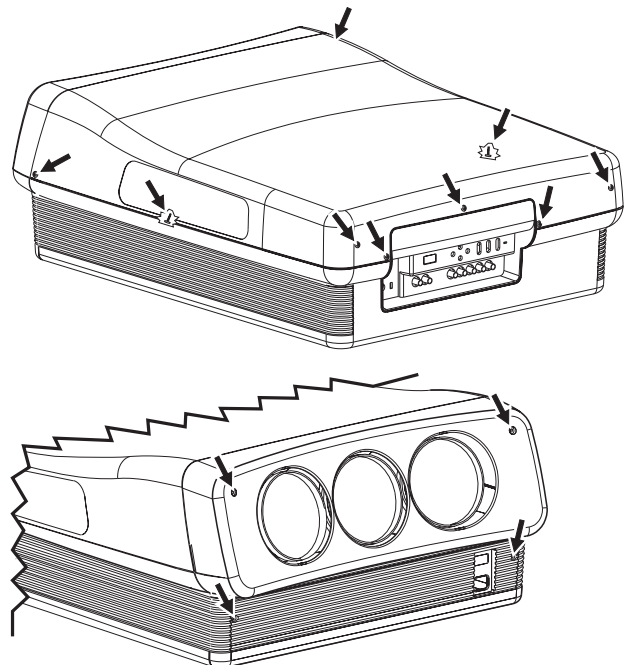

Standard Signal Format Modes

Mode Name	Freq.	Signal Type
1. ** Factory 1	15.7Khz	Video - NTSC
2. Factory 2	15.62khz	Video - PAL
3. VGA 400	31.46khz	RGB
4.* VGA480	31.46khz	RGB
5. VGA350	31.46khz	RGB
6. HDTV 33	31.75khz	RGB
7. MAC II 35	35.0khz	RGB
8.* #HDTV 45	45.0khz	RGB
9.* SVGA48	48.36khz	RGB
10. Factory 10	15.7Khz	Video - SVHS
11. <u>Return To Normal Viewing</u>		
* = 4:3 factory setup		
** = 4:3, 16:9 factory setup		
*# = 16:9 factory setup		

REAR VIEW

Be sure to read and understand the setup section before you attempt to install a PRO900X system; you will find tables and examples of the required installation data for a successful installation. Also, the user Operating Guide and

Warranty is included with the PRO900X. Read the user menu section to understand the features and functions for normal system operation. There are no field required adjustments to the service menu.

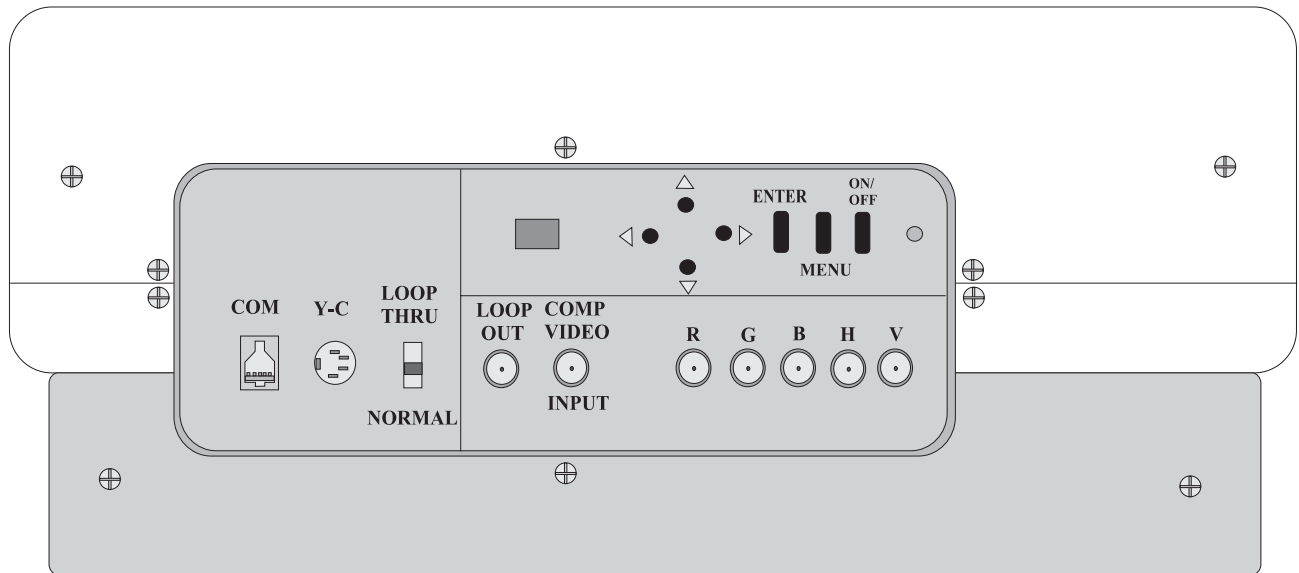

Status LEDs

- Standby - 5VDC is present in the 9-1515 module.
- Horizontal Active - horizontal deflection yoke drive is present in the 9-1505 module.
- Vertical Active - vertical deflection yoke drive is present in the 9-1510 module.
- Video Enable - all conditions are ready for high voltage to turn on via the 9-1504 mc

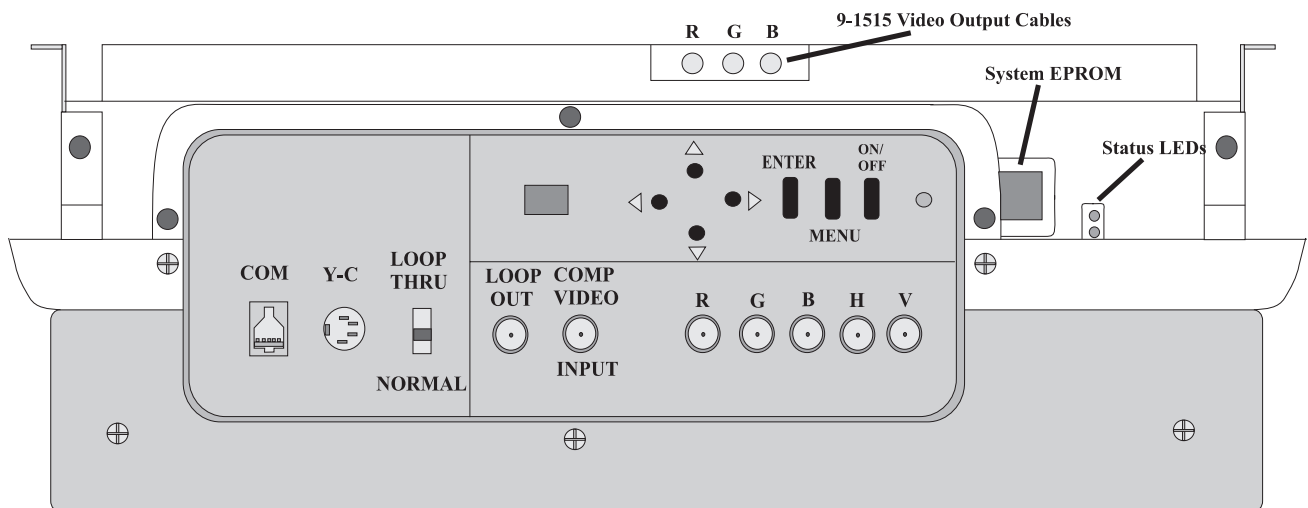

TOP / INSIDE VIEW

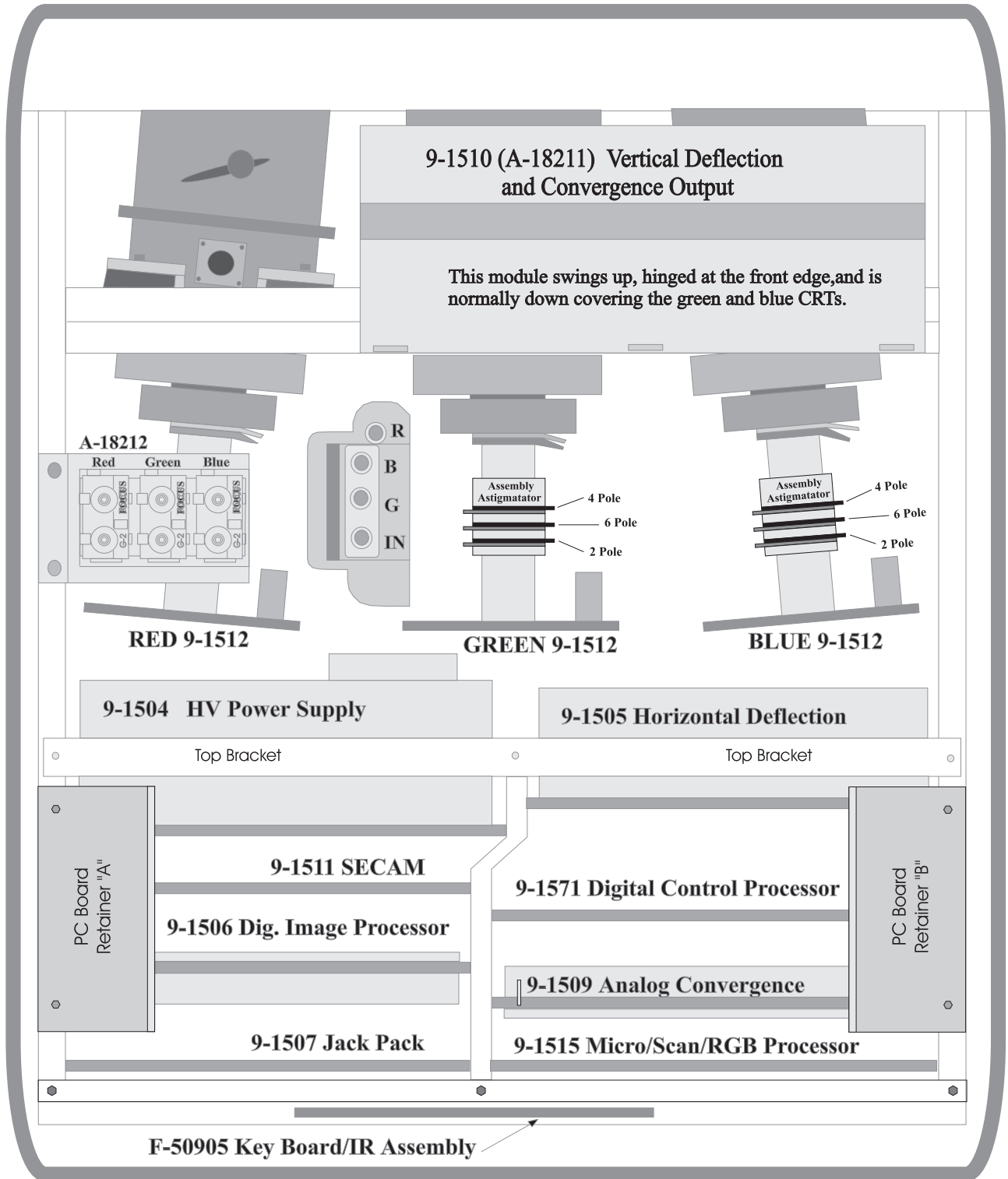

SETUP REMOTE CONTROL

The PRO900X will be supplied with the MBR3470T and a Universal customer remote control. For most servicing situations the MBR3470T is required. The MBR3470T has the special functions needed for geometry/convergence adjustments and system setup functions which the Universal customer remote cannot perform.

When using the MBR3470T, keep in mind this is a five-mode remote control. The mode functions at the top, CABLE, VCR, AUX, and TV are standard MBR programmable

functions. The SETUP mode is only for PRO900X setup / convergence use. To use the normal "user menu" (Source, Setup, or Video) the system must be out of the convergence setup mode. The user menus will indicate the current setting by highlighted text or a bar / number indication in the dialog box at the bottom of the screen. The exception is the Source menu which has the three choices with the current selected source being highlighted and control instructions in the dialog box.

Customer Menu Functions

Setup Mode Functions

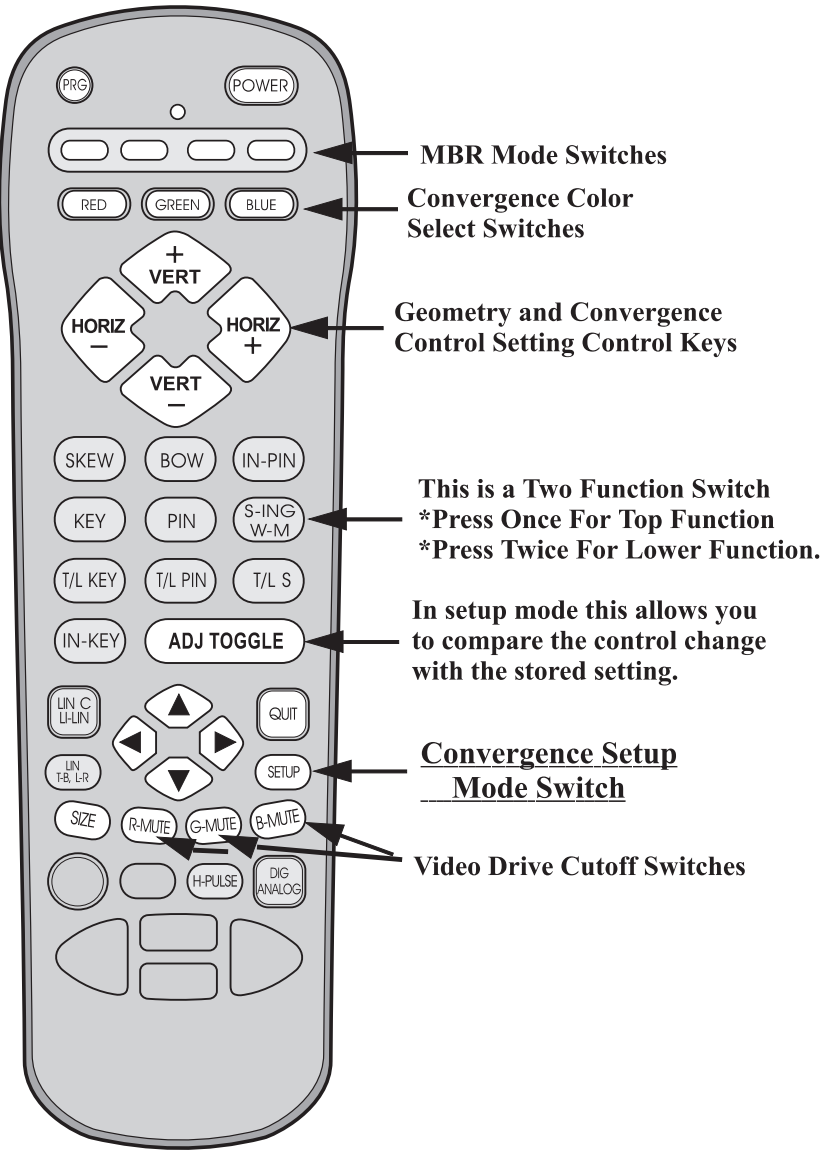
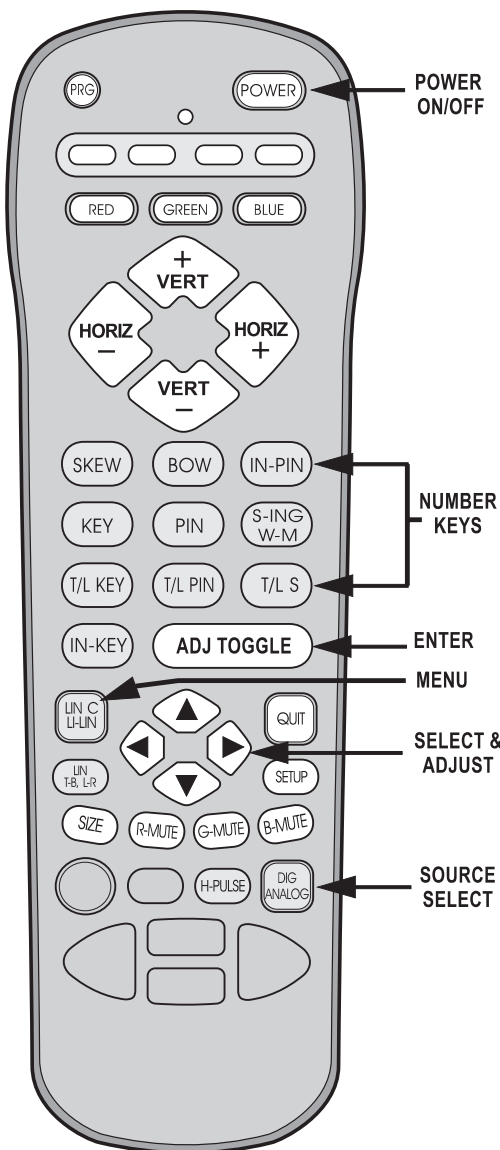

This is a Two Function Switch
*Press Once For Top Function
*Press Twice For Lower Function.

In setup mode this allows you to compare the control change with the stored setting.

Convergence Setup Mode Switch

Video Drive Cutoff Switches

SETUP MODE NOTES AND CAUTIONS

- When you enter the setup mode, the system is in the "Geometry Mode" (the shape controls adjust all three colors at the same time). To adjust an individual color (i.e. Red to adjust SKEW), you must press the "Red Select" key. This will put the system into the "Convergence Mode" (the shape controls adjust one color at a time). To return to the Geometry Mode, you must press the "Red Select" key a second time.
- When you are adjusting all colors ("geometry mode") the little arrow keys at the bottom are for video phase adjust only. When they are pressed, the remote will switch the geometry control to phase. If the arrow keys have not been touched for a few seconds, the remote will automatically switch back to the geometry control you were last using before using the small arrows.
- When you are adjusting an individual color ("convergence mode") the little arrow keys at the bottom are for DC Centering only. When they are pressed, the remote will switch the convergence control to DC Centering. If the arrow keys have not been touched for a few seconds, the remote will automatically switch back to the convergence control you were last using before using the small arrows.
- The setup controls, in the on screen display, are usually labeled with Horz/Vert, T/L (top/left), or B/R (bottom/right) and a number value indicating the current setting.
- If you want to see what effect the "new setting" compared to the "stored setting" has on the display, press the "ADJ TOGGLE" key on the remote. Adjust toggle will allow you to switch between the two settings before committing to a change.
- After making your changes and adjustments, be sure you SAVE THE NEW SETTINGS. If a major change has been made, new module, new CRT, or a change in the physical setup, you must re-adjust and store the geometry/setup for each of the formats and aspect ratios being used.
- To escape from the setup mode, without saving any changes, press the "Quit" key twice.
- Caution - shut all the PRO900X timers and signal source power conserve features off before starting convergence. If the video signal is lost, you will quit convergence mode with no chance to save your work.
- To display the Forced Mode Menu press "SETUP" and "GREEN SELECT".
- To display the current sync and video format being used press, "GREEN MUTE".
- To see the elapsed time display, press and hold "LIN C/LI-LIN", until the regular menu disappears, and then press the "TIMER" or "H-Pulse" key.
- To set the unit IR Code (for use when multiple units are in the area), press and hold "LIN C/LI-LIN", until the regular menu disappears, and then press "T/LS", "T/LS", "T/LS", "T/LS", and "ADJ TOGGLE".
- Copying Formats Procedure
Copy the setup information (Convergence, blanking, phase, chromatics, and aspect ratio) from one defined format to another defined format. Procedure quickly copies unrecognized new formats or existing formats to one of the five available "Customer" defined format spaces. The ten factory format presets cannot be overwritten. To display the Copy Format Menu, press "R-MUTE". Use the Left/Right arrows to select the format you want to copy. Use the Up/Down arrows to change the menu option from "Copy From" to "Copy To". Use ENTER to initiate copying the format to the newly specified customer format (Customer 1, Customer 2, etc.) If a format already exists in the selected Customer format space, it will be overwritten by the new format when ENTER is pressed. QUIT exits the menu without making any changes.
- To aid with the alignment procedure, it is recommended that you mark the center of the screen and the center of all four sides with masking tape. Use "drafting" type tape that will not leave any marks. This will give you calibration points for convergence and CRT alignments.

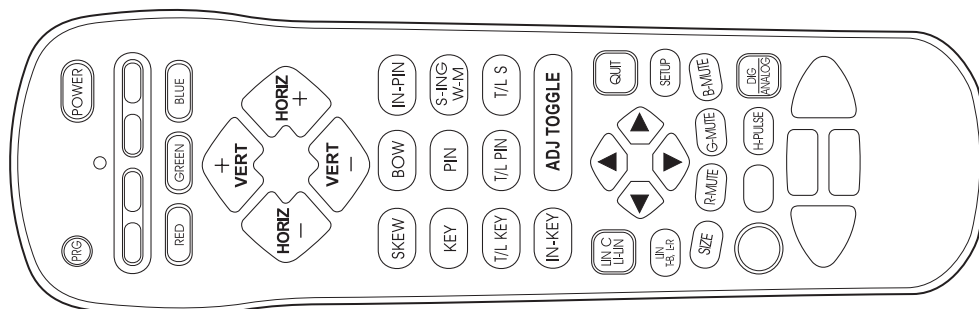

SPECIFICATIONS FOR RGB SYNC INPUTS

Version 2.1 December 21, 1995

I. SYNC INPUTS

There are three Sync signal inputs for use with RGB sources:

1. SYNC-ON-GREEN (SOG) - - this is through the Green video input BNC jack, terminated 75 ohms.
2. HORIZONTAL/COMPOSITE (H / Comp) - - through a BNC jack on the 9-1515 Combo module, software switchable termination 2K/75 ohms.
3. VERTICAL (V) - - through a BNC jack on the 9-1515 Combo module, software switchable termination 2K/75 ohms.

II. COMPATIBILITY

1. SYNC-ON-GREEN - - negative-going sync on Green video input, either EIA or SMPTE (HD) spec compatible.
2. HORIZONTAL/COMPOSITE
 - a. Analog/TTL Mode - - TTL-level computer syncs (VGA, SVGA, Macintosh), NTSC/PAL/SECAM studio/commercial horizontal/composite analog sync.
 - b. Special Composite Mode - - NTSC/PAL/SECAM or SMPTE HD studio/commercial negative composite or tri-level analog sync (Black Video).
3. VERTICAL - - TTL-level computer syncs (VGA, SVGA, Macintosh), NTSC/PAL/SECAM studio/commercial negative vertical analog sync.

III. FREQUENCY RANGE

1. SYNC-ON-GREEN - - Horizontal component: 15kHz to 50kHz. Vertical component: 50 to 100 Hz.
2. HORIZONTAL/COMPOSITE - - Horizontal component: 15kHz to 50kHz. Vertical component: 50 to 100 Hz.
3. VERTICAL - - 50 to 100 Hz.

IV. AMPLITUDE

1. SYNC-ON-GREEN - - Sync portion: 300mV, +/- 150mV.
2. HORIZONTAL/COMPOSITE
 - a. Analog/TTL Mode - - 0.7Vp-p to 5Vp-p.
 - b. Special Composite Mode - - 300mV, +/- 150mV.
3. VERTICAL - - 0.7Vp-p to 5Vp-p.

V. POLARITY

1. SYNC-ON-GREEN - - negative.
2. HORIZONTAL/COMPOSITE
 - a. Analog/TTL Mode - - positive or negative.
 - b. Special Composite Mode - - negative.
3. VERTICAL - - positive or negative.

VI. PULSE WIDTH OR DUTY CYCLE

1. SYNC-ON-GREEN - - Minimum sync pulse width = 400nS.
2. HORIZONTAL/COMPOSITE
 - a. Analog/TTL Mode. - - Max duty cycle of sync pulse ($V_{sync\ in} = 0.7Vp-p$) = 15% Max duty cycle of sync pulse ($V_{sync\ in} = 1.4Vp-p$) = 30%.
 - b. Special Composite Mode - - Minimum sync pulse width = 400nS.
3. VERTICAL - - Max duty cycle of sync pulse ($V_{sync\ in} = 0.7Vp-p$) = 15% Max duty cycle of sync pulse ($V_{sync\ in} = 1.4Vp-p$) = 30%.

NOTES

SCREEN SIZE SELECTION

Courtesy of Draper Shade & Screen

One of the most important decisions in screen selection is to determine the correct size of screen based upon-

1. The dimensions of the audience area.
2. The projection format, or formats, to be used.

In some situations, these two questions yield the same answer; in others they do not and compromises must be made. Here are the key considerations:

Audience Area-In determining the correct size of screen in relation to the audience area, the goal is to make the size large enough so those in the rear of the audience area can see the subject matter easily, but not so large that those in the front of the audience area have difficulty seeing the full width of the projected image.

Width-The generally accepted guideline in determining the screen width is the Two and Six Rule:

- A. Screen width should equal the distance from the screen to the first row of seats, divided by two.
- B. Screen width should equal the distance from the screen to the last row of seats, divided by six.

In case of a difference between these two guidelines, the one yielding the larger size should prevail.

Height-As a rule of thumb, the screen height should equal or exceed the distance from the screen to the last row of seats, divided by eight. Ceiling height and projection format considerations may modify this standard.

Ceiling Height-The bottom of the screen should be approximately 48" above the floor to allow all members of the audience to see the bottom of the projected image.

Projection Format-Once you have determined the correct size of the screen based upon the audience area, that size may be based upon the type, or types, of projection equipment to be used. If the screen will only be used with one type of projector (overhead projector, CRT video projector, etc.), it is easy to determine the exact screen dimensions based upon the projection format of that projector. Projection formats are expressed in terms of aspect ratio, which is the relationship of the height of the projected image to its width. Aspect ratios of common projection formats are listed below.

If it is necessary to modify the screen dimensions based upon the formats of projectors to be used, it is preferable to hold the screen height constant and increase the screen width as necessary, rather than to hold the width constant and decrease the height.

ASPECT RATIOS OF COMMON PROJECTION FORMATS

H:W

1.00:1.00	Overhead and opaque projection,
1.00:1.78 or 9:16	High Definition Television (HDTV) Anamorphic Video
1.00:1.33 or 3:4	LCD and CRT video and data-graphics projection
1.00:1.85	Wide Screen
1.00:2.35	CinemaScope
1.00:1.48 or 2:3	2x2 standard slides (35mm DF)

Note - Vertical presentation of a slide reverses its aspect ratio. To allow this, use a 1.00: 1.00 aspect ratio for any type slide.

Projection Formats

Most models of DRAPER screens are offered in both audio visual and 3:4 video formats. Certain models are also offered in HDTV and WideScreen formats. The differences between these formats are stated below.

We are glad to provide any DRAPER screen in the size and projection format of your choice. We can provide any size up to and including the largest published size. If you do not find the size and format you need listed, please call or fax your requirement to us, and we will be delighted to quote.

Audiovisual (or AV) format screens are intended for general use. They accommodate a variety of projector types and range from square to wide horizontal in aspect ratio.

AV format screens are described in terms of height x width, and are standardly furnished without black borders, although borders are optionally available.

Video format screens, on the other hand, are specifically designed for use with video projectors. Their format is strictly defined as a 3:4 rectangle, and the size is usually described in terms of a nominal diagonal. Conventional models of video format screens are standardly furnished with black borders to frame the image on all four sides, allowing for video projector overscan. Tab Tensioned electric screens are routinely furnished with black borders at the sides and bottom, although black masking at the top is optionally available.

HDTV format (9 high by 16 wide) is also available for high-definition television projection, Anamorphic Video and Wide sssScreen format (1: 1.85).

How to Calculate a Custom Size

Draper also manufactures custom size screens to meet your specification. Virtually any size within the maximum shown for a given model is available. Please call for pricing on special sizes. If you need to calculate a custom size, these formulas may be useful (D = exact diagonal; H viewing area height; W = viewing area width):

3:4 Video:

$$\begin{aligned}H &= D \times .6 \\W &= D \times .8 \\D &= H \times 1.667, \\D &= W \times 1.25\end{aligned}$$

9:16 HDTV:

$$\begin{aligned}H &= D \times .49 \\W &= D \times .87146 \\D &= H \times 2.04 \\D &= W \times 1.1475\end{aligned}$$

1:1.85 wide screen:

$$\begin{aligned}H &= D \times .4762, \\W &= D \times .881, \\D &= H \times 2.1, \\D &= W \times 1.135\end{aligned}$$

SETUP AND ALIGNMENT PROCEDURE

PROCEDURE OVERVIEW

There are several situations to consider when performing the setup procedure for the PRO900X System. The setup procedure will vary depending on the required physical and signal configuration.

The simplest setup is that of a "factory configured" projector which will use the preset conditions. Factory configured means it has been aligned for ceiling/front projection and a 80" wide display at a projected distance of 96 3/8". In this case, using the customer's signal source, only minor blanking, phase, and convergence touch up is required.

If the display size is changed, to other than 80" width or the unit is to be floor-mounted, completion of the full setup procedure is required.

Setup, after a hardware repair, is the other condition.

Replacement of a CRT usually requires minor alignment steps (yoke, astigmatator, focus, and re-convergence only for that color). Replacement of modules, in the vertical, horizontal deflection, or convergence systems, usually requires that most all alignment steps are to be performed.

I. INSTALLATION PREREQUISITES

1. Mounting Configuration - Floor or Ceiling.
2. Projection Configuration - Front or Rear.
3. Determine Display Size and Aspect Ratio (Shape).
4. List All Signal Source(s) and Format(s).
5. Check Projection Installation Area - Before Installation.
6. Survey Installation Area For Power and Signal Source Requirements.
7. Test PRO900X system before modifying its configuration.
8. Modify, Install, and Set Up the PRO900X system.

II. SYSTEM CHECK AND PHYSICAL SETUP

1. PRO900X Check Out Before Changes to Configuration
 - IMPORTANT** Do Not Connect Power until you verify correct setup of the 120/230 VAC jumper on the 9-1500 power supply. Refer to the illustration at the right.
 - a. Connect all the customer's RGB and Video Source(s) to the PRO900X jackpack.
 - b. Turn on the PRO900X and the Signal Source(s).
 - c. Verify that the PRO900X recognizes all the source signals.
 - d. Verify that the PRO900X operates correctly.
 - e. Turn the PRO900X off and disconnect the AC power.
2. Set Floor/Ceiling and Front/Rear Configuration. Refer to the figures on page 19.
 - a. Remove the PRO900X top cover.
 - b. 9-1510 Module set vertical deflection and horizontal/vertical convergence connectors.
 - c. 9-1505 module set horizontal deflection connectors.
 - d. 9-1509 module set dynamic focus switch SW7001.
3. Set Red and Blue CRT Point Angles *Set angles only if the setup is a non-factory configuration (other than 80" wide image.)*
 - a. Remove the nylon rod shipping spacers (or shipping wedges).
 - b. Set Red CRT point angle according to the display width.

- c. Set Blue CRT point angle according to the display width. Refer to the figures on page 20.

Note: The PRO900X unit is shipped with spacer shims between the CRT and lens assemblies, these must be removed to set up the "Scheimpflug (spring/edge)" focus. Refer to the figure on page 23 for the edge focus procedure.

4. Mount the projector system.

Mount the PRO900X system according to the prearranged plans agreed upon between the installer and end user. Verify the mounting point, hardware, signal connections, and power connections.

Note: It is recommended that preliminary setup be done on the floor before hanging a ceiling-configured system.

5. Projector/Display Surface Physical Setup
 - a. Set the projector to screen distance according to display width. Refer the figures on pages 20 and 21.
 - b. Set projector height according to display size. Refer to the figures on pages 20 and 21.
 - c. Adjust the projector's position for no horizontal skew to the display screen.
 - d. Verify that the Green CRT center is centered to the screen horizontal center.
 - e. Stabilize the projector and screen mounting hardware.
 - f. Verify that the setup of steps "a" through "d" has not changed.
6. Set Up Signal Sources
 - a. Connect the RGB and/or Video Source(s) to the PRO900X jackpack.
 - b. Reconnect the AC power.
 - c. Turn on the PRO900X and the Signal Source(s).
 - d. Verify that the PRO900X recognizes all the source signals.
 - e. Set the "Ceiling/Floor" setup menu option.

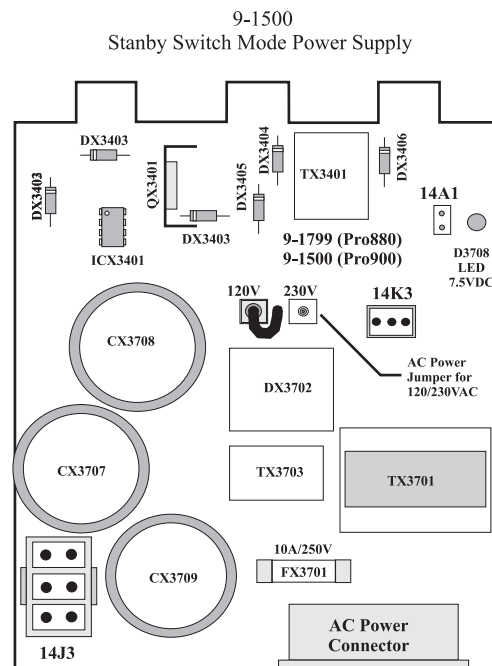

SETUP REFERENCES

9 - 1505 Module

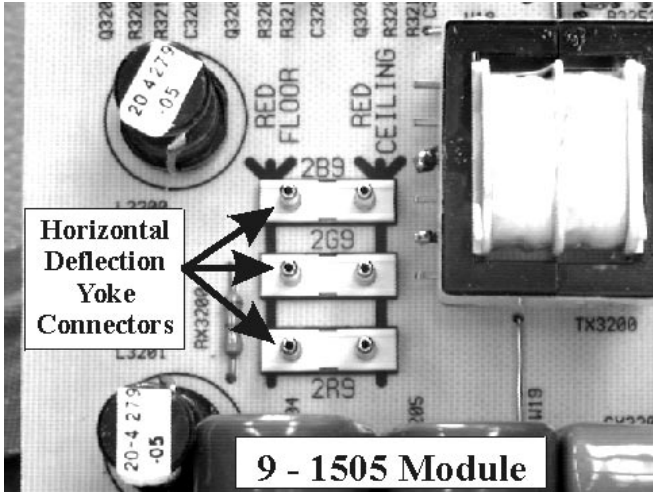

Top View

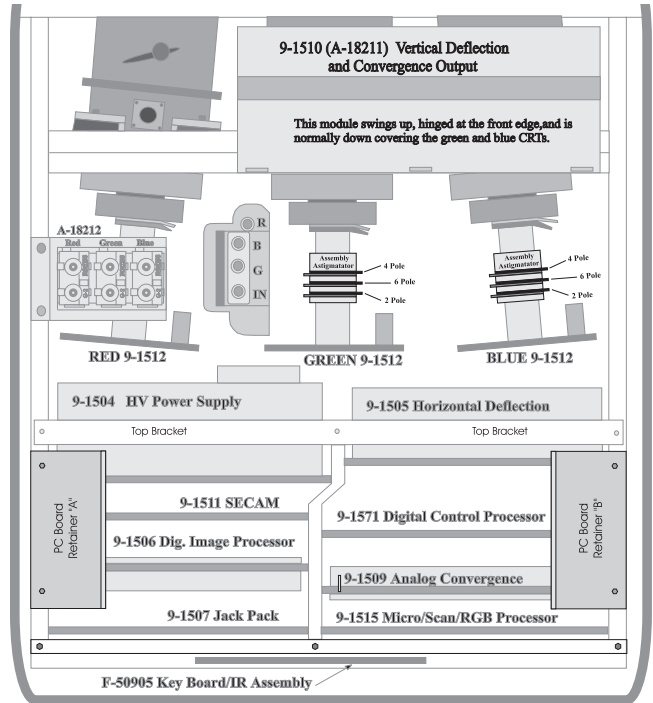

9 - 1510 Module

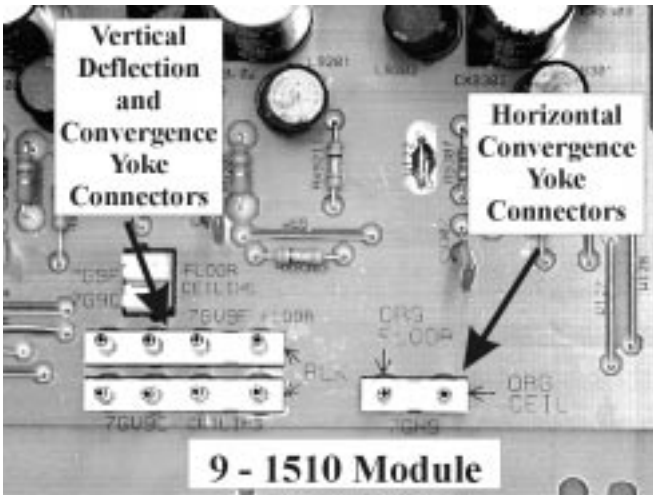

Setup Menus

SETUP is used to adjust geometry and convergence settings.

Press RED to continue **SETUP**.
Press GREEN to force formats.
Press BLUE to set floor / ceiling.
Press any other key to exit.

9 - 1509 Module Top Edge

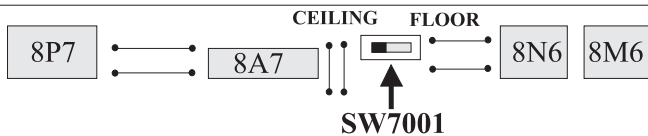

Top Edge Of The 9-1509 Module

SETUP Position = Floor.
Press **To change selection.**

PHYSICAL SETUP

EXAMPLES OF DISPLAY SETUP DISTANCES AND CENTER POINTS

Screen Width	"A"* Projection Distance	"B" Display Center	"Peerless" Mount Center
48"	58 5/8"	26 3/8"	11"
60"	72 7/8"	30 3/4"	11"
80"	96 3/8"	38"	11"
96"	115 1/4"	43 5/8"	11"
120"	143 1/2"	52 3/8"	11"
144"	171 7/8"	61"	11"
160"	190 5/8"	66 3/4"	11"
200"	237 7/8"	81 1/8"	11"

Note: Distance "A" is measured from the cabinet panel front directly below the green CRT lens.

- Calculate the Display Center "B" from a reference line projected from the bottom of the cabinet. Display Center "B" = $A \times 0.3057$ + 8.44.
- Set the projector's height using measurement "B". This references the bottom of the cabinet to the display center. When doing a ceiling mount, be sure to allow for the dimensions of the mounting bracket hardware.
- Ensure that the projector is mounted horizontally centered and perpendicular to the screen.
- The Peerless ceiling-mount center is 11" from the "A" distance reference point on the PRO900X front.

PHYSICAL SETUP TO THE SCREEN (for all aspect ratios)

- Set distance "A" according to the selected display width (* or calculate the distance in inches "A" = 1.179 x width) + 2.063

CRT Front View

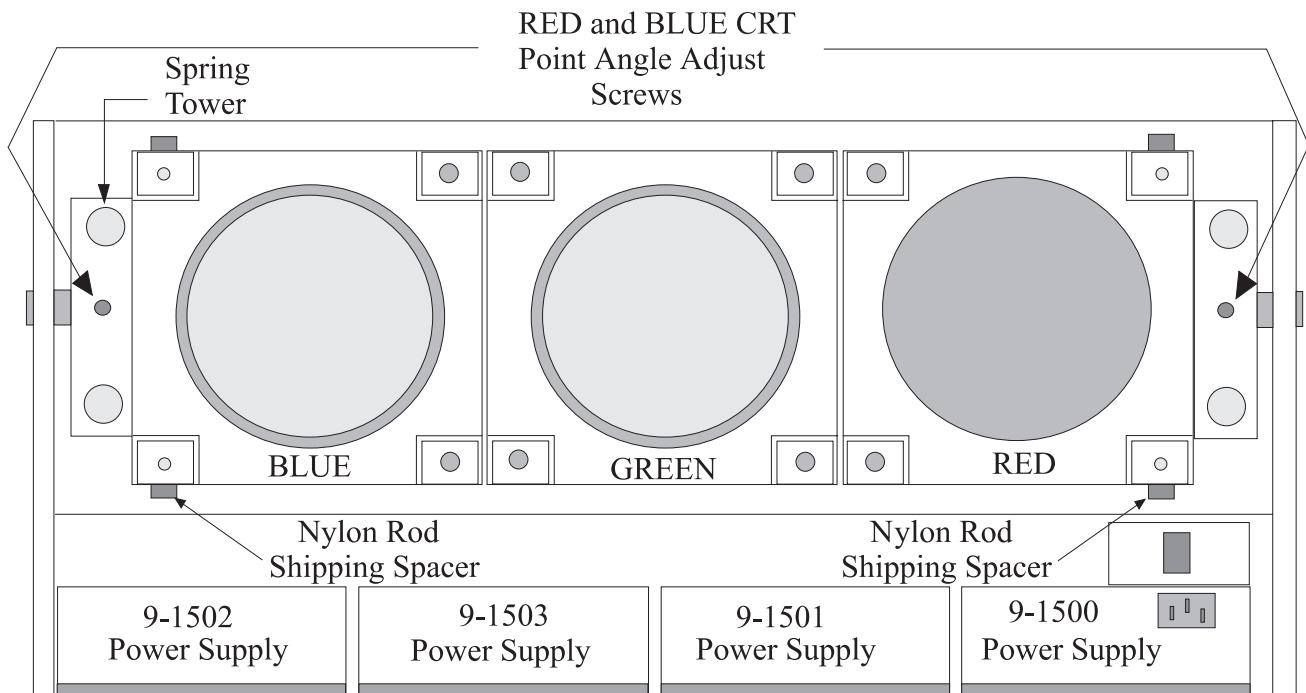

This projection system comes set up for Ceiling Mount and a display width of 80". To change the display width, two shipping spacer rods for the RED and BLUE CRTs, must be removed. This allows the RED and BLUE CRT point angles to be set for the new display width.

SYSTEM ALIGNMENT

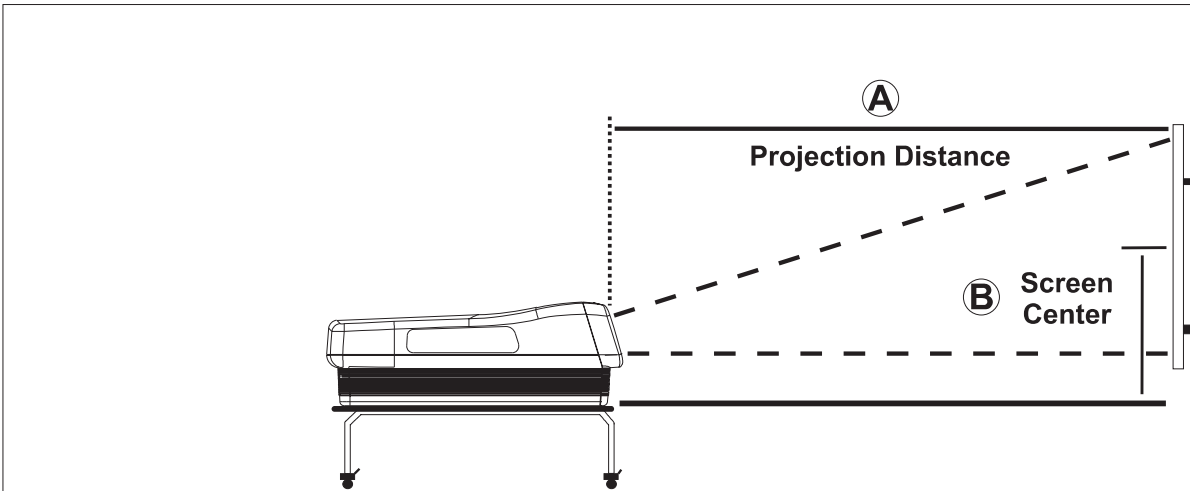
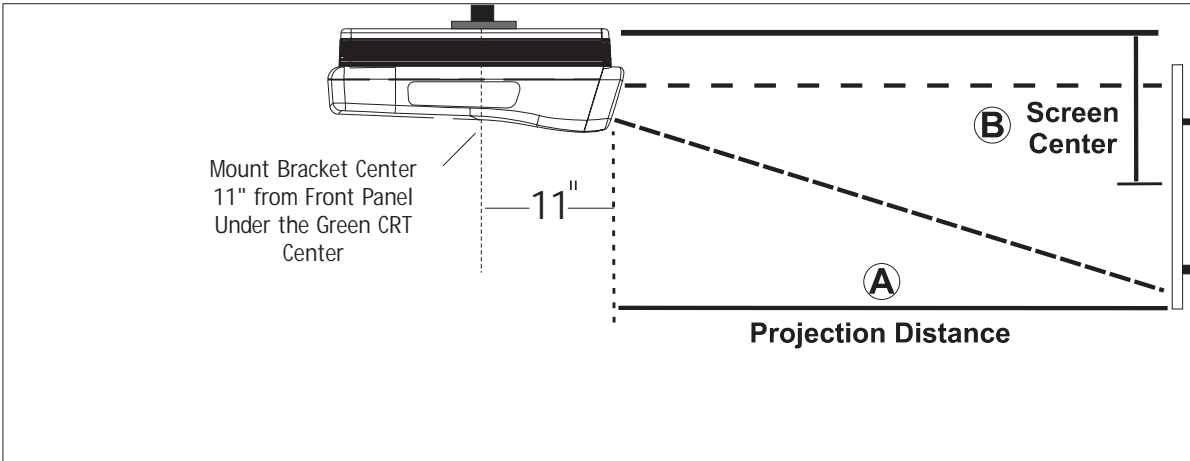

SYSTEM ALIGNMENT

III. PRELIMINARY ALIGNMENT SETUP

The following procedures are intended for complete "Geometry/Convergence" setup. Use the customer's signal for doing phase, and size adjustments. You can use the internal patterns for shape and convergence if the customer signal sources do not have a cross-hatch pattern.

If you are realigning a single CRT, due to replacement, or doing alignment touch up, perform the following steps as needed.

1. Yoke Tilt Alignment

Use a cross-hair or cross-hatch pattern. Monitor only the center-most horizontal line of the pattern to check yoke tilt.

Do not use SW9501, on the 9-1510 module, to disable convergence. The vertical circuit is not disabled, only the horizontal is disabled.

- Set Horizontal DC centering to "0" (red, green, blue).
- Set Vertical DC centering:
 - Floor: Red = -30; Green = -20; Blue = -30.
 - Ceiling : Red = 30; Green = 20; Blue = 30.
- In geometry mode and convergence mode (green, red, and blue) set "SKEW" H = 0 and "SKEW" V = 0.
- Adjust the Red, Green, and Blue yokes for no horizontal tilt or twist.

2. Yoke Ring Magnet and Astigmatator Alignment

Verify Only - This is not a normal field adjustment.

The astigmatator assembly should be mounted 62.5 mm from the video output module (from the front edge of the video output module to the six pole rings). Refer to the figure on page 24.

Astigmatator Alignment Verification Test

Adjust for the best electrical and mechanical focus.

Verify spot alignment by rotating Green electrical focus slightly CW to CCW. The Dot shape should not tail or flair. The bright area should remain in the center of the haloed area. Refer to the figure below.

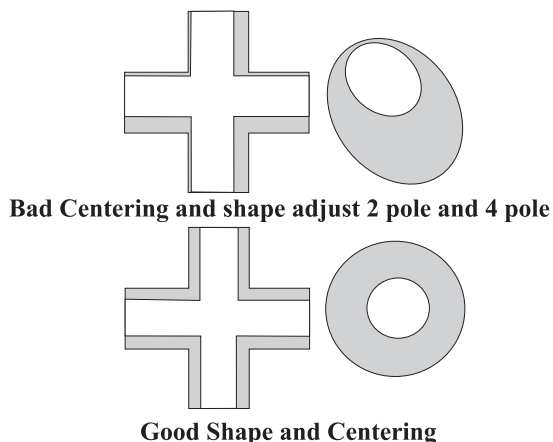

If this test shows a need for astigmatator alignment perform steps "a" - "l" below.

Astigmatator Alignment Procedure

- Set the display/sync mode to Forced Mode 6 (HDTV33) and select a cross-hatch or dot pattern.
- Cut off Red and Blue video or cover the CRT lens assemblies.
- Set Green electrical focus slightly CCW. This is to make a near display center dot dimly haloed with a bright center. The haloed effect will also be visible with the cross-hatch lines.
- Use the astigmatator 4-pole magnet to shape the halo and bright spot as round as possible.
- Use the astigmatator 6-pole magnet, if needed, to help shape the halo and spot round.
- Use the astigmatator 2-pole magnet (refer to the figure at bottom left of this page) to center the bright spot within the halo. You may also use an intersection, of the cross-hatch, to center the bright area within the haloed area.
- Use the main yoke magnets to position the signal raster center to the CRT face center. Refer to figure below.

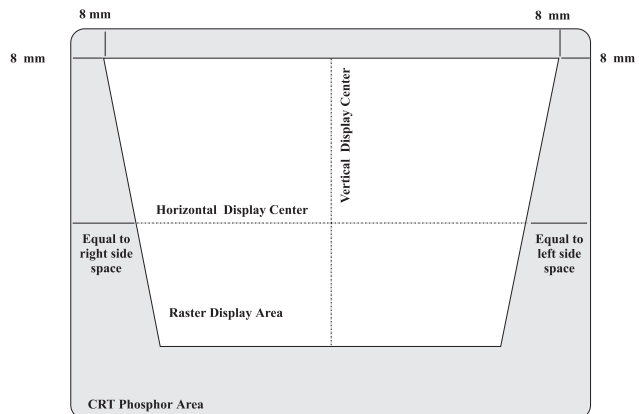

The center of the video pattern display should be in the center of the CRT phosphor area. Video pattern display is vertically compressed below the horizontal center of the display..

- Verify spot alignment by rotating Green electrical focus slightly CW to CCW. The Dot shape should not tail or flair. The bright area should remain in the center of the haloed area.
- Repeat steps "c" thru "h" as needed to obtain the smallest and best round Green center dot with no shape flaring.
- Adjust for the best electrical and mechanical focus.
- Repeat steps "c" - "j" for the Red and Blue displays.
- Exit forced mode 6 and return to normal video. Set Brightness and Contrast to 50.

Note: The yoke adjustments should not be touched during the remaining setup steps.

3. Ceiling/Front Projection Lens Angle Focus Alignment

If this PRO900X system is equipped with the "lens assembly focus" spring, the following procedure must be completed. This procedure must be completed as part of the system mechanical

SYSTEM ALIGNMENT

Lens Assembly
Barrel Focus

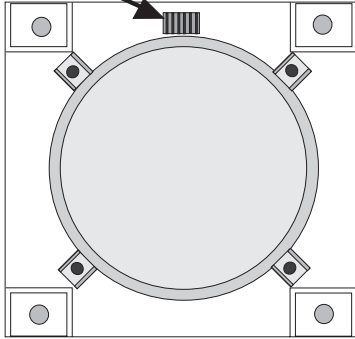

Red, Green, and Blue Lens Assemblies

focus procedure. See the figure above.

- a. Turn on the projector, project a cross-hatch pattern on the screen. Cover up both the Blue and Red lenses. Work only on the Green lens.
- b. Tighten all 4 lens mounting screws.
- c. Loosen all 4 lens mounting screws 3 full turns.
- d. Adjust the mechanical and electrical focus to get the best image possible in the center of the picture.
- e. Loosen the lens focus adjustment knob. Fully extend the lens barrel. Adjust mechanical focus while observing the center horizontal line. Adjust until one side (left or right) comes sharply into focus. Adjust the two screws opposite the side that is in focus (i.e., if the left side of the center horizontal line is in focus, adjust the two screws on the right side of the lens). Turn each screw 1/4 - 1/2 turn at-a-time in the same direction (in or out) while observing the focus of the center horizontal line. If the sharp focus begins to move towards the center of the image, you are going in the wrong direction (in or out). Adjust in the correct direction until the entire line achieves a uniform soft focus from left to right. You should then be able to adjust the barrel focus to get the center horizontal line sharp all the way across. If not, you can fine adjust with this same procedure.
- f. Loosen the lens focus adjustment knob. Fully extend the lens barrel. Adjust mechanical focus while observing the center vertical line. Adjust until one side (top or bottom) comes sharply into focus. Adjust the two screws opposite the side that is in focus (i.e., if the bottom of the center vertical line is in focus, adjust the two screws on the top of the lens). Turn each screw 1/4 - 1/2 turn at a time in the same direction (in or out) while observing the focus of the center vertical line. If the sharp focus begins to move towards the center of the image, you are going in the wrong direction (in or out). Adjust in the correct direction until the entire line achieves a uniform soft focus from top to bottom. You should then be able to adjust the barrel focus to get the entire image

sharp all the way across (top to bottom and left to right). If not, you can fine adjust with this same procedure.

Note: Throughout this procedure pay no attention to the corners of the image.

- g. Adjust the focus mechanically and electrically to get the best overall image.
- h. Cover the Green lens and uncover the Red lens.
- i. Repeat step "b" - "g" for Red.
- j. Cover the Red lens and uncover the Blue lens.
- k. Repeat steps "b" - "g" for Blue.
- l. Re-install PRO900X top cover.
- m. Turn off the sync forced mode 9 and return to normal video viewing or sync forced mode 11.

4. Rough Geometry/Convergence Setup of Green

When aligning Green, some controls are enabled in Geometry only. This is why the alignment starts by using Green in the geometry mode of setup.

- a. Using the setup remote control, press "SETUP" and "RED". This will put the system into the "GEOMETRY MODE".
- b. Using the setup remote control press "RED MUTE" and "BLUE MUTE". You should see only the Green video.
- c. Roughly set up the shape of the Green display using the appropriate Skew, Bow, Key, etc. controls. Adjust size, or phase using the customer's video signal. Refer to pages 25, 26, and 27 for the convergence remote control and procedure notes.

5. Rough Geometry/Convergence of Red and Blue

- a. Using the remote control, return to the SETUP Mode and select the internal cross-hatch pattern.
- b. Press "RED" and mute the Blue video.
- c. Using the "Point Angle" adjustment screws, align the Red center point horizontally with the Green center point.
- d. Using DC vertical center, align the horizontal center line of the Red pattern to the horizontal center line of the Green pattern.
- e. Adjust Red "Size" and "Lin T/B - L/R " to roughly match the Green pattern size. Refer to pages 25, 26, and 27.
- f. Roughly set up the shape of the Red display using the appropriate Skew, Bow, Key, etc. controls. Refer to pages 25, 26, and 27.
- g. Press "BLUE" and mute the Red video.
- h. Using the "Point Angle" adjustment screws, align the Red center point horizontally with the Green center point.
- i. Using DC vertical center, align the horizontal center line of the Blue pattern to the horizontal center line of the Green pattern.
- j. Adjust Blue "Size" and "Lin T/B - L/R " to roughly match the Green pattern size. Refer to pages 25, 26, and 27.
- k. Roughly set up the shape of the blue display using the appropriate Skew, Bow, Key, etc. controls. Refer to pages 25, 26, and 27.
- l. Press "QUIT" and "ADJ TOGGLE" to store the adjustments.

Continued on next page.

SYSTEM ALIGNMENT

IV. Final Detailed Geometry/Convergence Setup

Use the video patterns generated by the customer's signal source for final alignment. If this is not possible, use the internal cross hatch pattern only to do the geometry and convergence. The customer's signal must be used for blanking, size, centering and phase.

1. Green Geometry Setup
 - a. Return to the geometry and convergence modes and set up the Green display with precision. Each step should be done by measuring the display and not guess work.
 - b. Now store the Green setup.
2. Red to Green Convergence Setup
 - a. Return to the convergence mode and set up the red display with precision. Converge the Red display to the Green display using all necessary controls.
 - b. Now store the Red setup.
3. Blue to Green Convergence Setup
 - a. Return to the convergence mode and set up the Blue display with precision. Converge the Red display to the Green display using all necessary controls.
 - b. Now store the Blue setup.
4. Red to Green to Blue Convergence Setup
 - a. Return to the convergence mode and set up the Red and Blue display with precision. Converge the Red display to the Green display using all necessary controls.
 - b. Now store the completed setup.

5. Video Blanking Setup Using the Customer's Signal
 - a. Access the Blanking/Phase feature of the setup menu.
 - b. Select the TOP/LEFT BLANKING feature.
 - c. Using the small arrows adjust the top and left edges (increasing the setting number) until the edge begins to crop or frame the video. Decease the number until the cropping just stops. Now decease the number value two more.
 - d. Select the BOTTOM/RIGHT BLANKING feature, repeat step c.
 - e. Press ADJ TOGGLE and save the settings.

V. Geometry/Convergence of Other Aspect Ratios

1. Geometry/Convergence setup must be accomplished for each required aspect ratio of each signal format used (Video, S-Video, RGB VGA400, VGA480, SVGA, etc.).
2. Each of the ten standard signal format memory "custom" locations also has a "custom" location for each of associated aspect ratios.
3. The five "customer" format memory locations also store the aspect ratio information separately.
4. RGB sources use the 4 x 3, letter box, or 16 x 9 aspect ratios.
5. Video and S-Video sources use the 4 x 3, letter box, Compressed, and 16 x 9 aspect ratios.

Installed CRT Assembly

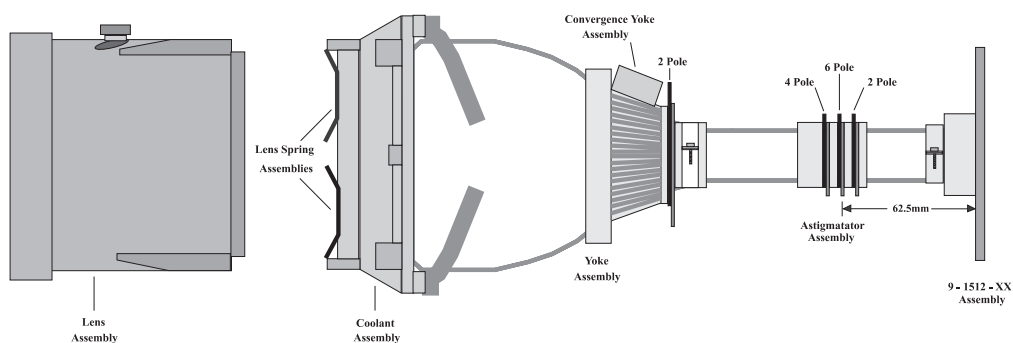

Replacement CRT Assembly

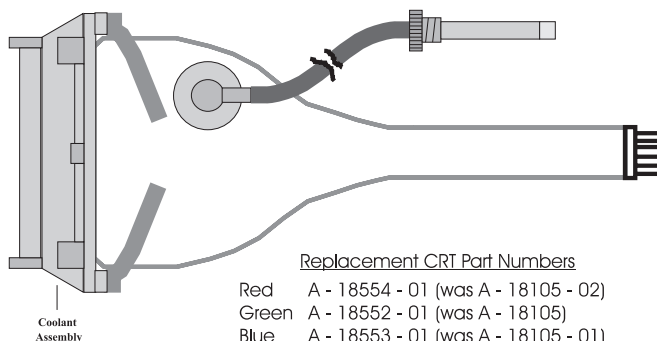

Replacement CRT Part Numbers

Red A - 18554 - 01 (was A - 18105 - 02)
 Green A - 18552 - 01 (was A - 18105)
 Blue A - 18553 - 01 (was A - 18105 - 01)

Transferred Assemblies

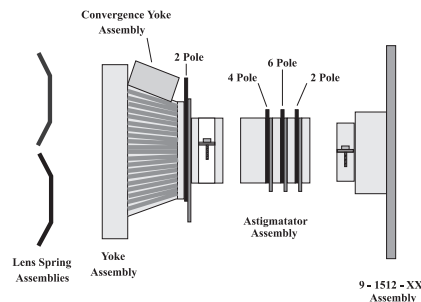

SYSTEM ALIGNMENT

DIGITAL DISPLAY SETUP PROCEDURE GEOMETRY CONVERGENCE

Geometry controls all three colors at the same time. January 1998

Remote Key	Adjustment	Goal	Remote Key	Adjustment	Goal
1. SIZE	H. Size	Set to fill screen at C and D. (Use external source not internal test pattern)	19. T/L KEY	V. Top Key	Set top edge E-F straight with respect to screen border.
2. SIZE	V. Size	Set to fill Screen at A and B. (Use external source not internal test pattern.)	20. T/L PIN	V. Top Pin	Set for straight top edge, line E-F.
3. LIN TB LR	H. Lin L-R	Set equal widths CZ=ZD	21. T/L S	V. Left S	Set for straight edge, line E-F (middle areas J & L move opposite; center A and ends E & F are stable).
4. LIN TB LR	V. Lin T-B	Set equal height AZ=ZB	22. T/L KEY	H. Left Key	Set left edge E-G straight with respect to screen border top and bottom move in opposite directions, center C is stable).
5. LIN C	H. Lin C	Set box width at center equal to average of left and right box widths and size.	23. T/L PIN	H. Left Pin	Set for straight left edge, line E-G (corners E & G move, center C is stable).
6. LIN C	V. Lin C	Set box heights at center equal to average of top and bottom box widths and size.	24. T/L S	H. Left S	Set for straight left edge, line E-G (middle areas N & P move opposite; center C and ends E & G are stable).
7. SMALL ARROWS	H&V Video Phase	Set the position of the external source to be centered on the screen.	25. IN-KEY	H. In Key	Set J-K and L-M straight with respect to line E-G, A-B, and F-H (adjust for minimal internal keystone; top bottom move in opposite directions; centers 3 and 4 are stable).
8. SKEW	V. Skew	Level line C-D.	26. IN-PIN	H. In Pin	Set J-K and L-M straight (adjust for minimal internal pincushion).
9. BOW	Bow V.	Straighten line C-D (note that some screen frames are curved).	27. W-MV	W-M	Average error for straightest lines G-H and E-F (middle areas K & M, and J & L move in same direction; center B, A and ends G & H, are stationary).
10. SKEW	H. Skew	Line A-B edges equal distance to screen edge.	28. Touch up all controls		Due to the interaction of IN-XXX controls, key controls, and pin controls for best overall convergence, it may be necessary to 'tweak' the other controls.
11. BOW	H. Bow	Straighten Line A-B			
12. KEY	V. Key	Set bottom edge G-H straight with respect to screen border.			
13. PIN	V. Pin	Set for straight bottom edge, line G-H (corners G & H move, center B is stable.)			
14. S-ING	V. 'S'	Set for straight bottom edge, line G-H (middle areas K & M move in opposite direction, center B; and ends G & H are stable).			
15. W-M	V. W-M	Adjust for straightest line G-H (middle areas K & M move in same direction, center B and ends G & H are stationary).			
16. KEY	H. Key	Set right edge F-H straight with respect to screen border (top and bottom move in opposite directions; center D is stable.)			
17. PIN	H. Pin	Set for straight right edge, line F-H (corner F&H move, center D is stable.)			
18. S-ING	H. 'S'	Set for straight right edge, line F-H (middle areas O & Q move opposite and center D and ends F & H are stable.)			

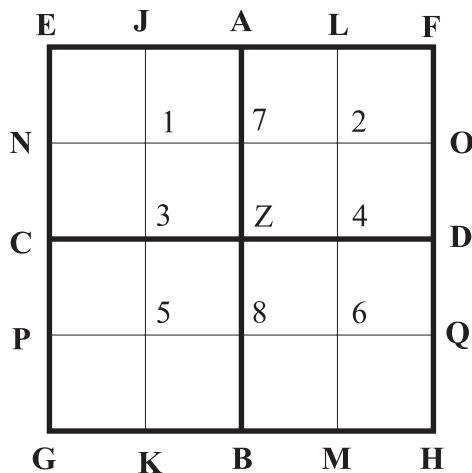

Convergence Setup Controls

#1 - #28 are figure references and not the adjustment order.

→ = Area to focus your attention

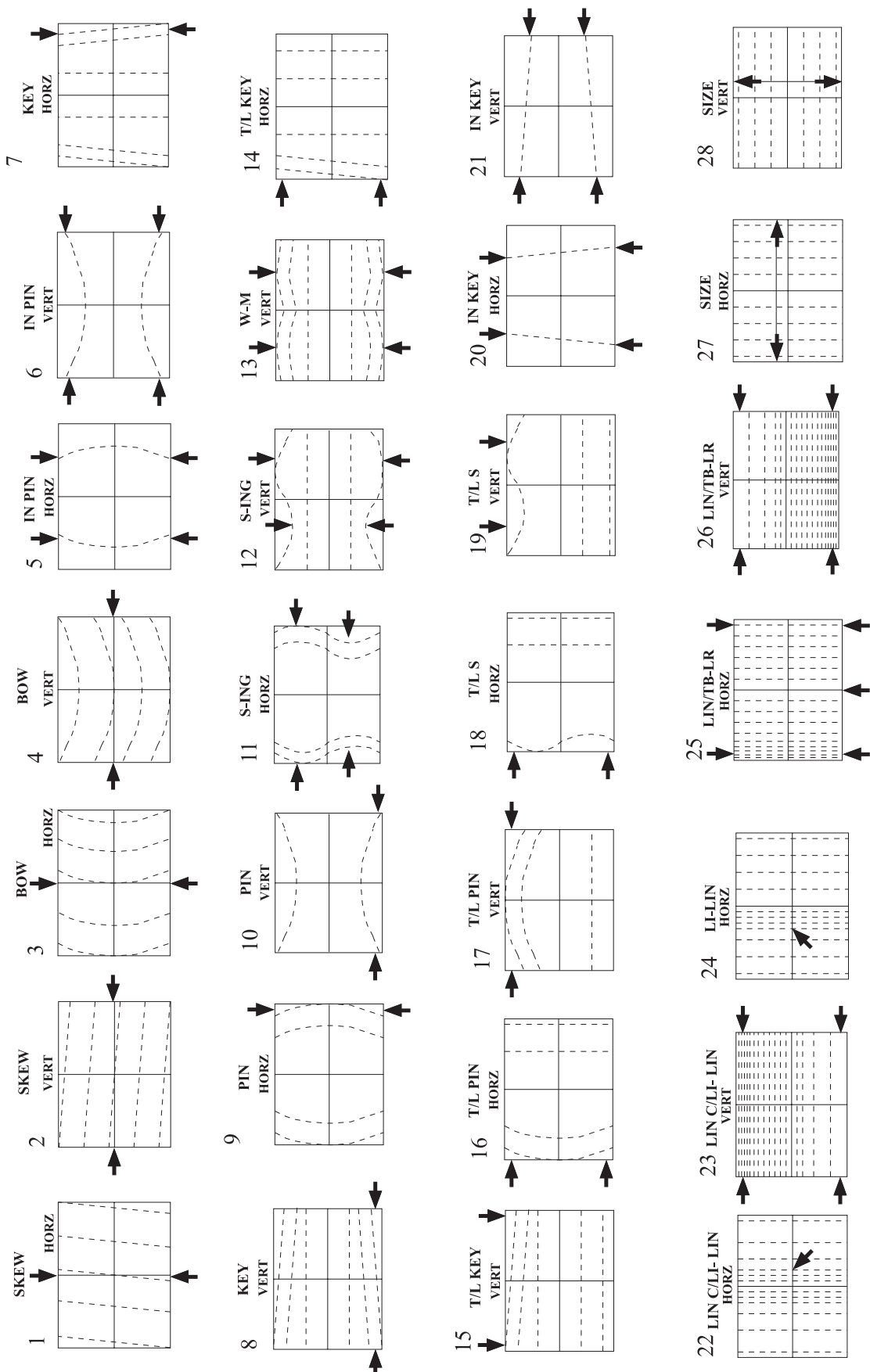

SYSTEM ALIGNMENT

DIGITAL DISPLAY SETUP PROCEDURE CONVERGENCE OF RED AND BLUE ONTO GREEN

It is desirable to Mute color you are not adjusting. Select the color you want to adjust by pressing the RED or BLUE key.

Remote Key	Adjustment	Goal	Remote Key	Adjustment	Goal
1. SMALL ARROWS	H. & V. Statics	Set center of video for best overlap with Green (this may have to be 'tweaked' during this alignment procedure.)	19. S-ING	H. 'S'	Balance error at right edge in areas & Q (middle areas O & Q move in opposite direction; center D and ends F & H are stationary).
2. SIZE	H. Size	Set to match Green at C and D.	20. T/L KEY	V. Top Key	Balance error with Green at top corners E & F straight with respect to screen border (left and right move in opposite directions; center A is stable).
3. SIZE	V. Size	Set to match Green at A and B.	21. T/L KEY	V. Top Pin	Match Green at top edge comers E & F (comers E & F move in same direction; center A is stable).
4. LIN T-B L-R	H. Lin L-R	Match Green at C and D; Iterate with H. Size if necessary.	22. T/L S-ING	V. 'S'	Balance error at bottom edge in areas J & L (middle areas J & L move in opposite directions; center A and ends E & F are stationary).
5. LIN T,B L-R	V. Lin T-B	Match Green at A and B iterate with V. Size if necessary.	23. T/L KEY	H. Left Key	Balance error with Green at left corners E & G (top and bottom move in opposite directions; center C is stable).
6. LIN C and H. SIZE	Lin C and SIZE	Match Green at 4, center line vertical axis, midway between Z and D.	24. T/L PIN	H. Left Pin	Match Green at left edge corners E & G (corners E & G move in same direction, center C is stable).
7. LI-LIN	H. LI LIN	Match Green at 3, center line vertical axis, midway between C & Z and LI-LIN (Press key twice to get the second function.) Caution: H. LIN C also affects this; adjust in correct order above.)	25. T/L S-ING	H. 'S'	Balance error at left edge in areas N & P (middle areas N & P move in opposite directions; center C and ends E & G are stationary).
8. LIN C	V. Lin C	Match Green at 7 and 8.	26. IN KEY	H. In Key	Average error with Green in middle areas J, K, and L, M (ends move in opposite direction centers 3 & 4 are stable, may require iteration with H. Skew, H. Key).
9. SKEW	V. Skew	Match Green at C and D.	27. IN PIN	H. In Pin	Match Green in middle areas J, K, and L, M (ends move in same direction: center is stable; may require iteration with H. Bow, H. Pin).
10. BOW	V. Bow	Match Green at C and D.	28. IN KEY	V. In Key	Average error with Green in middle areas N, O, and P, Q (ends move in opposite direction centers 7 & 8 are stable, may require iteration with V. Skew, V. Key).
11. SKEW	H. Skew	Match Green at A and B.	29. IN-PIN	V. In Pin	Match Green in middle areas N, O and P, Q (may require iteration with V. Bow, V. Pin)
12. BOW	H. Bow	Match Green at A and B.	30. Touch up all controls		Due to the interaction of IN-Controls, Key Controls and Pin controls for best overall convergence, it may be necessary to tweak the other controls. This should only require minor adjustments of each control.
13. KEY	V. Key	Balance error with Green at bottom edge G-H (left and right edges move in opposite directions; center is stable).			
14. PIN	V. Pin	Match Green at right edge corners G & H (corners G & H move in same direction; center B is stable).			
15. S-ING	V. 'S'	Balance error at bottom edge in areas K & M (middle areas K & M move in opposite directions; center B and ends G & H are stationary).			
16. W-M	V. W-M	Balance error at bottom edge in areas K & M (middle areas K & M move in same direction, center B and ends G & H are stationary).			
17. KEY	H. key	Balance error with Green at right edge corners F & H (top and bottom move in opposite directions; center D is stable).			
18. PIN	H. Pin	Match Green at F & H (corners F & H move in same direction; center D is stable).			

It may be necessary to perform this procedure twice to get optimal performance.

NOTES
